

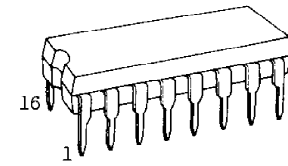

TC4528BP/TC4528BF DUAL MONOSTABLE MULTIVIBRATOR

TC4528BP/BF contains two circuits of monostable multivibrators with the capabilities of retrigger operation and reset operation in one chip. The trigger operation can be achieved either by rising edge or falling edge if one of two inputs A and B are selected. As the pulse width of mono-stable multivibrator output is determined by the time constant of external resistor (Rx) and external capacitor (Cx), wide range of output pulse width can be obtained. The asynchronous reset operation from outside can be achieved by setting CD input to "L" level, and this CD input can be also applied for inhibiting the trigger operation and for shortening the time period from turning the power on the time when TC4528B becomes able to perform the mono-stable operation.



DIP16(3D16A-P)

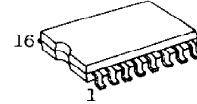

MFP16(F16GC-P)

ABSOLUTE MAXIMUM RATINGS

CHARACTERISTIC	SYMBOL	RATING	UNITS
DC Supply Voltage	V _{DD}	V _{SS} - 0.5 ~ V _{SS} + 20	V
Input Voltage	V _{IN}	V _{SS} - 0.5 ~ V _{DD} + 0.5	V
Output Voltage	V _{OUT}	V _{SS} - 0.5 ~ V _{DD} + 0.5	V
DC Input Current	I _{IN}	±10	mA
Power Dissipation	P _D	300(DIP)/180(MFP)	mW
Operating Temperature Range	T _A	-40 ~ 85	°C
Storage Temperature Range	T _{stg}	-65 ~ 150	°C
Lead Temp./Time	T _{sol}	260°C · 10 sec	

PIN ASSIGNMENT

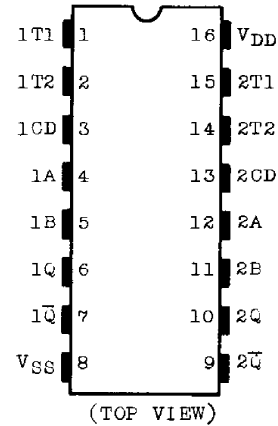

LOGIC DIAGRAM

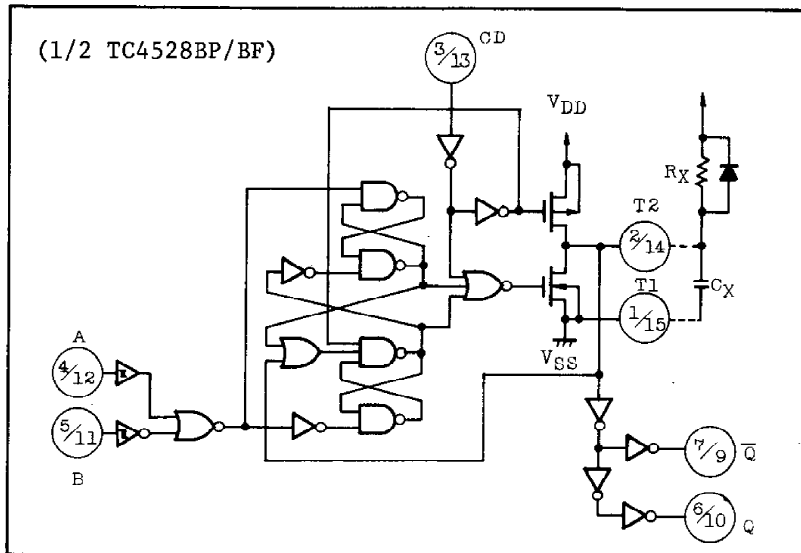

TRUTH TABLE

INPUT			OUTPUT		NOTE
A	B	CD	Q	Q̄	
	H	H			OUTPUT PULSE
	L	H	L	H	INHIBIT
H		H	L	H	INHIBIT
L		H			OUTPUT PULSE
*	*	L	L	H	INHIBIT

* Don't Care

TIMING CHART

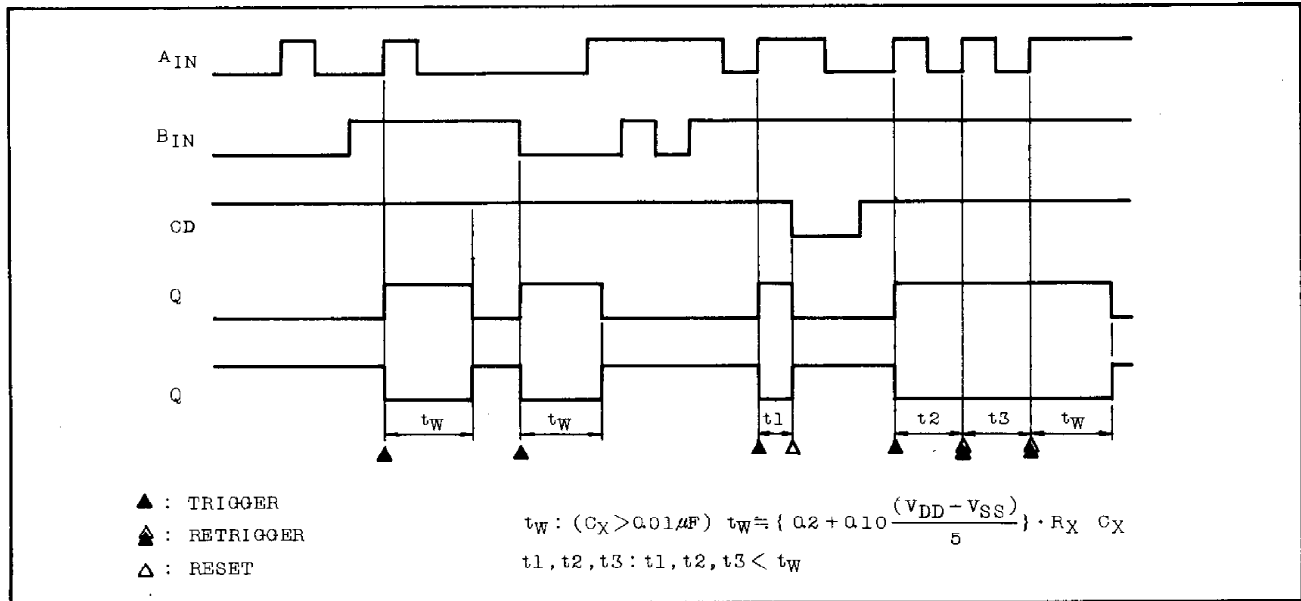

RECOMMENDED OPERATING CONDITIONS (V_{SS}=0V)

CHARACTERISTIC	SYMBOL	MIN.	TYP.	MAX.	UNITS
DC Supply Voltage	V _{DD}	3	-	18	V
Input Voltage	V _{IN}	0	-	V _{DD}	V
External Resistance	R _X	5	-	1000	kΩ
External Capacitance	C _X	No Limits			μF

STATIC ELECTRICAL CHARACTERISTICS (V_{SS}=0V)

CHARACTERISTIC	SYMBOL	TEST CONDITIONS	V _{DD} (V)	-40°C		25°C			85°C		UNITS
				MIN.	MAX.	MIN.	TYP.	MAX.	MIN.	MAX.	
High-Level Output Voltage	V _{OH}	I _{OUT} < 1μA V _{IN} =V _{SS} , V _{DD}	5	4.95	-	4.95	5.00	-	4.95	-	V
			10	9.95	-	9.95	10.00	-	9.95	-	
			15	14.95	-	14.95	15.00	-	14.95	-	
Low-Level Output Voltage	V _{OL}	I _{OUT} < 1μA V _{IN} =V _{SS} , V _{DD}	5	-	0.05	-	0.00	0.05	-	0.05	V
			10	-	0.05	-	0.00	0.05	-	0.05	
			15	-	0.05	-	0.00	0.05	-	0.05	
Output High Current	I _{OH}	V _{OH} =4.6V V _{OH} =2.5V V _{OH} =9.5V V _{OH} =13.5V V _{IN} =V _{SS} , V _{DD}	5	-0.61	-	-0.51	-1.0	-	-0.42	-	mA
			5	-2.5	-	-2.1	-4.0	-	-1.7	-	
			10	-1.5	-	-1.3	-2.2	-	-1.1	-	
			15	-4.0	-	-3.4	-9.0	-	-2.8	-	
Output Low Current	I _{OL}	V _{OL} =0.4V V _{OL} =0.5V V _{OL} =1.5V V _{IN} =V _{SS} , V _{DD}	5	0.61	-	0.51	1.2	-	0.42	-	mA
			10	1.5	-	1.3	3.2	-	1.1	-	
			15	4.0	-	3.4	12.0	-	2.8	-	

STATIC ELECTRICAL CHARACTERISTICS (Continued)

CHARACTERISTIC	SYMBOL	TEST CONDITIONS	V _{DD} (V)	-40°C		25°C			85°C		UNITS	
				MIN.	MAX.	MIN.	TYP.	MAX.	MIN.	MAX.		
Input High Voltage	V _{IH}	V _{OUT} =0.5V, 4.5V	5	3.5	-	3.5	2.75	-	3.5	-	V	
		V _{OUT} =1.0V, 9.0V	10	7.0	-	7.0	5.5	-	7.0	-		
		V _{OUT} =1.5V, 13.5V	15	11.0	-	11.0	8.25	-	11.0	-		
		I _{OUT} < 1μA										
Input Low Voltage	V _{IL}	V _{OUT} =0.5V, 4.5V	5	-	1.5	-	2.25	1.5	-	1.5	V	
		V _{OUT} =1.0V, 9.0V	10	-	3.0	-	4.5	3.0	-	3.0		
		V _{OUT} =1.5V, 13.5V	15	-	4.0	-	6.75	4.0	-	4.0		
		I _{OUT} < 1μA										
Input Current	"H" Level	I _{IH}	V _{IH} =18V	18	-	0.1	-	10 ⁻⁵	0.1	-	1.0	μA
	"L" Level	I _{IL}	V _{IL} =0V	18	-	-0.1	-	-10 ⁻⁵	-0.1	-	-1.0	
Quiescent Device Current	I _{DD}	V _{IN} =V _{SS} , V _{DD} *	5	-	5	-	0.005	5	-	150	μA	
			10	-	10	-	0.010	10	-	300		
			15	-	20	-	0.015	20	-	600		

* All valid input combinations.

DYNAMIC ELECTRICAL CHARACTERISTICS (T_a=25°C, V_{SS}=0V, C_L=50pF)

CHARACTERISTIC	SYMBOL	TEST CONDITIONS	V _{DD} (V)	MIN.	TYP.	MAX.	UNITS
Output Transition Time (Low to High)	t _{TLH}		5	-	70	200	ns
			10	-	35	100	
			15	-	30	80	
Output Transition Time (High to Low)	t _{THL}		5	-	70	200	ns
			10	-	35	100	
			15	-	30	80	
Propagation Delay Time (A, B - Q, Q̄)	t _{pLH}	R _X =5kΩ C _X =15pF	5	-	230	650	ns
			10	-	110	240	
			15	-	80	180	
	t _{pHL}	R _X =10kΩ C _X =1000pF	5	-	440	-	μs
			10	-	220	-	
			15	-	160	-	
Propagation Delay Time (CD - Q, Q̄)	t _{pLH}	R _X =10kΩ C _X =10000pF	5	-	2.2	5	μs
			10	-	1.1	3	
			15	-	0.9	2	
Propagation Delay Time (CD - Q, Q̄)	t _{pHL}	R _X =5kΩ C _X =15pF	5	-	150	600	ns
			10	-	70	225	
			15	-	50	170	
Propagation Delay Time (CD - Q, Q̄)	t _{pLH}	R _X =10kΩ C _X =1000pF	5	-	260	-	ns
			10	-	130	-	
			15	-	100	-	
	t _{pHL}	R _X =10kΩ C _X =10000pF	5	-	700	-	ns
			10	-	400	-	
			15	-	320	-	

DYNAMIC ELECTRICAL CHARACTERISTICS (Continued)

CHARACTERISTIC	SYMBOL	TEST CONDITION	V _{DD} (V)	MIN.	TYP.	MAX.	UNITS
Min. Input Pulse Width (A, B)	t_{WH} t_{WL}	$R_X=5k\Omega$	5	-	40	150	ns
		$C_X=15pF$	10	-	20	75	
		$C_X=15pF$	15	-	15	55	
Min. Retrieger Time	t_{rr}	$R_X=5k\Omega$	5	0	-	-	
		$C_X=15pF$	10	0	-	-	
		$C_X=15pF$	15	0	-	-	
		$R_X=10k\Omega$	5	0	-	-	
		$C_X=1000pF$	10	0	-	-	
		$C_X=1000pF$	15	0	-	-	
Output Pulse Width	$t_{w\ OUT}$	$R_X=5k\Omega$	5	-	190	-	
		$C_X=15pF$	10	-	140	-	
		$C_X=15pF$	15	-	140	-	
		$R_X=10k\Omega$	5	20	35	45	μs
		$C_X=1000pF$	10	35	45	55	
		$C_X=1000pF$	15	40	50	60	
Input Capacitance	C_{IN}			-	5	7.5	pF

WAVEFORM FOR MEASUREMENT OF DYNAMIC CHARACTERISTICS

