



M28W320FST M28W320FSB M28W320FSU M28W640FST M28W640FSB M28W640FSU

32 Mbit (2 Mb ×16) and 64 Mbit (4 Mb ×16)
3 V supply, Boot Block and Uniform Block, Secure Flash memories

Features

- Supply voltage
 - V_{DD} = 2.7 V to 3.6 V core supply voltage
 - V_{DDQ} = 2.7 V to 3.6 V Input/Output voltage
 - V_{PP} = 12 V Fast Program voltage (optional)
- Access time: 70 ns
- Programming time:
 - 10 μ s typical
 - Double Word Programming option
 - Quadruple Word Programming option
- Common Flash Interface
- Boot Block devices:
 - Parameter Blocks (top or bottom location)
 - Main Blocks
- 64-KWord Uniform Block devices:
 - M28W320FSU: 32 Blocks
 - M28W640FSU: 64 Blocks
- Hardware Protection
 - V_{PP} pin for write protect of all blocks
- Security features
 - 128 bit User-programmable OTP segment
 - 64 bit Unique Device Identifier
 - KRYPTO Features:
Modify Protection,
Read Protection,
Device Authentication
- Automatic Standby mode
- Program and Erase Suspend
 - 100 000 Program/Erase cycles per block

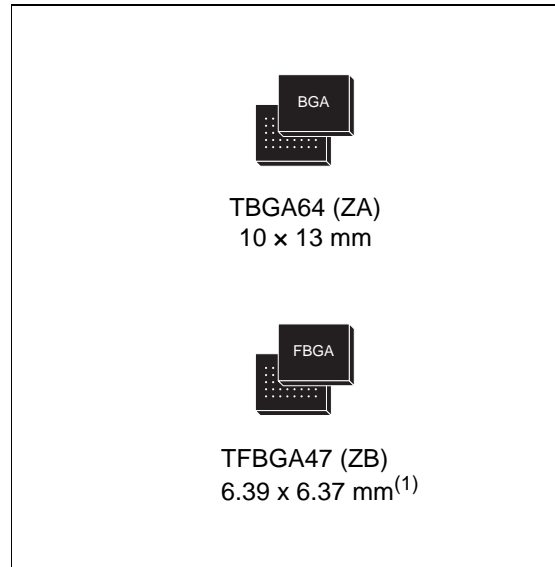

1. Only available in 32 Mbit devices.

- Electronic signature
 - Manufacturer Code: 20h
 - Device Codes:
M28W320FSU: 880Ch
M28W640FSU: 8857h
M28W320FST: 880Ah,
M28W320FSB: 880Bh
M28W640FST: 8858h,
M28W640FSB: 8859h
- ECOPACK® packages available

Contents

1	Description	6
2	Signal descriptions	14
2.1	Address Inputs	14
2.2	Data Input/Output (DQ0-DQ15)	14
2.3	Chip Enable (\overline{E})	14
2.4	Output Enable (\overline{G})	14
2.5	Write Enable (\overline{W})	14
2.6	Reset (\overline{RP})	14
2.7	V_{DD} Supply Voltage	15
2.8	V_{DDQ} Supply Voltage	15
2.9	V_{PP} Program Supply Voltage	15
2.10	V_{SS} Ground	15
2.11	V_{SSQ} Ground	15
3	Bus operations	16
3.1	Read	16
3.2	Write	16
3.3	Output Disable	16
3.4	Standby	16
3.5	Automatic Standby	17
3.6	Reset	17
4	Hardware Protection	18
5	Security features	18
6	Command Interface	19
6.1	Read Memory Array command	19
6.2	Read Status Register command	19
6.3	Read Electronic Signature command	19
6.4	Read CFI Query command	20

6.5	Block Erase command	21
6.6	Program command	21
6.7	Double Word Program command	22
6.8	Quadruple Word Program command	22
6.9	Clear Status Register command	22
6.10	Program/Erase Suspend command	23
6.11	Program/Erase Resume command	23
6.12	Protection Register Program command	23
7	Status Register	27
7.1	Program/Erase Controller Status (Bit 7)	27
7.2	Erase Suspend Status (Bit 6)	27
7.3	Erase Status (Bit 5)	28
7.4	Program Status (Bit 4)	28
7.5	V _{PP} Status (Bit 3)	28
7.6	Program Suspend Status (Bit 2)	28
7.7	Block Protection Status (Bit 1)	29
7.8	Reserved (Bit 0)	29
8	Maximum rating	30
9	DC and ac parameters	31
10	Package mechanical	40
11	Part numbering	42
	Appendix A Block address tables	43
	Appendix B Common Flash Interface (CFI)	58
	Appendix C Flowcharts and pseudo codes	65
	Appendix D Command Interface and Program/Erase Controller state	72
12	Revision history	75

List of tables

Table 1.	M28W320FS and M28W640FS memory architecture	7
Table 2.	Signal names	7
Table 3.	Bus operations	17
Table 4.	Command codes	20
Table 5.	Commands	24
Table 6.	Read Electronic Signature	25
Table 7.	Read Protection Register and Protection Register Lock	25
Table 8.	Program/Erase times and endurance cycles	26
Table 9.	Status Register bits	29
Table 10.	Absolute maximum ratings	30
Table 11.	Operating and ac measurement conditions	31
Table 13.	Capacitance	32
Table 14.	DC characteristics	33
Table 15.	Read ac characteristics	34
Table 16.	Write ac characteristics, Write Enable controlled	36
Table 17.	Write ac characteristics, Chip Enable controlled	38
Table 18.	Power-Up and Reset ac characteristics	39
Table 19.	TBGA64 - 10 × 13 active ball array, 1 mm pitch, package mechanical data	40
Table 20.	TFBGA47 - 8 × 6 active ball array, 0.75 mm pitch, package mechanical data	41
Table 21.	Ordering information scheme	42
Table 22.	Top Boot Block addresses, M28W320FST	43
Table 23.	Bottom Boot Block addresses, M28W320FSB	45
Table 24.	Top Boot Block Addresses, M28W640FST	47
Table 25.	Bottom Boot Block addresses, M28W640FSB	51
Table 26.	Block addresses, M28W320FSU	55
Table 27.	Block addresses, M28W640FSU	56
Table 28.	Query structure overview	58
Table 29.	CFI query identification string	59
Table 30.	CFI query system interface information	60
Table 31.	Device geometry definition	61
Table 32.	Primary algorithm-specific extended query table	63
Table 33.	Security code area	64
Table 34.	Write State Machine Current/Next, sheet 1 of 2	72
Table 35.	Write State Machine Current/Next, sheet 2 of 2	74
Table 36.	Document revision history	75

List of figures

Figure 1.	M28W320FS logic diagram	8
Figure 2.	M28W640FS logic diagram	8
Figure 3.	M28W320FSU logic diagram	9
Figure 4.	M28W640FSU logic diagram	9
Figure 5.	TBGA64 connections (top view through package)	10
Figure 6.	TFBGA47 connections (top view through package)	11
Figure 7.	M28W320FST and M28W320FSB block addresses	12
Figure 8.	M28W640FST and M28W640FSB block addresses	12
Figure 9.	M28W320FSU and M28W640FSU block addresses	13
Figure 10.	Protection Register memory map	13
Figure 11.	AC measurement load circuit	32
Figure 12.	Read ac waveforms	34
Figure 13.	Write ac waveforms, Write Enable controlled	35
Figure 14.	Write ac waveforms, Chip Enable controlled	37
Figure 15.	Power-Up and Reset ac waveforms	39
Figure 16.	TBGA64 - 10 × 13 active ball array, 1 mm pitch, bottom view package outline	40
Figure 17.	TFBGA47 - 8 × 6 active ball array, 0.75 mm pitch, view through package	41
Figure 18.	Program flowchart and pseudo code	65
Figure 19.	Double Word Program flowchart and pseudo code	66
Figure 20.	Quadruple Word Program flowchart and pseudo code	67
Figure 21.	Program Suspend & Resume flowchart and pseudo code	68
Figure 22.	Erase flowchart and pseudo code	69
Figure 23.	Erase Suspend & Resume flowchart and pseudo code	70
Figure 24.	Protection Register Program flowchart and pseudo code	71

1 Description

The M28W320FST, M28W320FSB, and M28W320FSU are 32 Mbit (2 Mbit × 16) Secure Flash memories; while the M28W640FST, M28W640FSB, and M28W640FSU are 64 Mbit (4 Mbit × 16). In the present datasheet, the M28W320FST and M28W320FSB will be referred to as M28W320FS, and the M28W640FST and M28W640FSB as M28W640FS.

The devices can be erased electrically at block level and programmed in-system on a Word-by-Word basis using a 2.7 V to 3.6 V V_{DD} supply for the circuitry and a 2.7 V to 3.6 V V_{DDQ} supply for the Input/Output pins. An optional 12 V V_{PP} power supply is provided to speed up customer programming.

The M28W320FS and M28W640FS are boot block Flash memories. They have an asymmetrical block architecture with 4 KWord Parameter Blocks and 32 KWord Main Blocks. The M28W320FST and M28W640FST have the Parameter Blocks at the top of the memory address space while the M28W320FSB and M28W640FSB locate the Parameter Blocks starting from the bottom. Refer to [Table 1](#), [Figure 7](#), [Figure 8](#) and [Figure 9](#) for a detailed description of the devices memory architecture and map.

The M28W320FSU and M28W640FSU are uniform block Flash memories. They are divided into thirty-two and sixty-four 64-KWord Uniform blocks, respectively. Refer to [Figure 7](#) for a detailed description of the devices memory architecture and map.

All devices are equipped with hardware and software block protection features to avoid unwanted program/erase (modify) or read of the Flash memory content:

- Hardware Protection:
 - When $V_{PP} \leq V_{PPLK}$ all blocks are protected against program or erase.
- Software Protection thanks to Krypto™ Security Features:
 - Modify Protection: volatile and non-volatile.
 - Read Protection.

The Krypto Security features are described in a dedicated Application Note. Please contact STMicroelectronics for further details.

Two registers are available for protection purpose:

- The Protection Register
- The Krypto Protection Register.

The Protection Register is a 192 bit Protection Register to increase the protection of a system design. The Protection Register is divided into a 64 bit segment and a 128 bit segment. The 64 bit segment contains a unique device number written by ST, while the second one is one-time-programmable by the user. The user programmable segment can be permanently protected. [Figure 10](#), shows the Protection Register Memory Map.

The Krypto Protection Register is used to manage the Modify and Read protection modes. It also features a Device Authentication mechanism. The Krypto Protection Register is described in a dedicated Application Note. Please contact STMicroelectronics for further details.

Each block can be erased separately. Erase can be suspended in order to perform either read or program in any other block and then resumed. Program can be suspended to read data in any other block and then resumed. Each block can be programmed and erased over 100,000 cycles.

Program and Erase commands are written to the Command Interface of the memory. An on-chip Program/Erase Controller takes care of the timings necessary for program and erase operations. The end of a program or erase operation can be detected and any error conditions identified. The command set required to control the memory is consistent with JEDEC standards.

All the devices are offered in TBGA64 (10 × 13mm) packages. 32 Mbit devices are also delivered in TFBGA47 (6.39 × 6.37mm) packages.

In order to meet environmental requirements, ST offers the devices in ECOPACK® packages. ECOPACK packages are Lead-free. The category of second Level Interconnect is marked on the package and on the inner box label, in compliance with JEDEC Standard JESD97. The maximum ratings related to soldering conditions are also marked on the inner box label. ECOPACK is an ST trademark. ECOPACK specifications are available at: www.st.com.

All devices are supplied with all the bits erased (set to '1').

Table 1. M28W320FS and M28W640FS memory architecture

Device	Parameter Blocks		Main Blocks	
	No. of Blocks	Block Size ⁽¹⁾	No. of Blocks	Block Size
M28W320FS	8	4 KWords	63	32 KWords
M28W640FS	8	4 KWords	127	32 KWords

1. Erasable Block size.

Table 2. Signal names

M28W320FST, M28W320FSB, M28W320FSU	M28W640FST, M28W640FSB, M28W640FSU	Signal names
A0-A20	A0-A21	Address Inputs
DQ0-DQ15		Data Input/Output
\bar{E}		Chip Enable
\bar{G}		Output Enable
\bar{W}		Write Enable
$\bar{R}\bar{P}$		Reset
V_{DD}		Core Power Supply
V_{DDQ}		Power Supply for Input/Output
V_{PP}		Optional Supply Voltage for Fast Program & Erase
V_{SS}		Ground
V_{SSQ}		Ground Input/Output supply
NC		Not Connected Internally

Figure 1. M28W320FS logic diagram

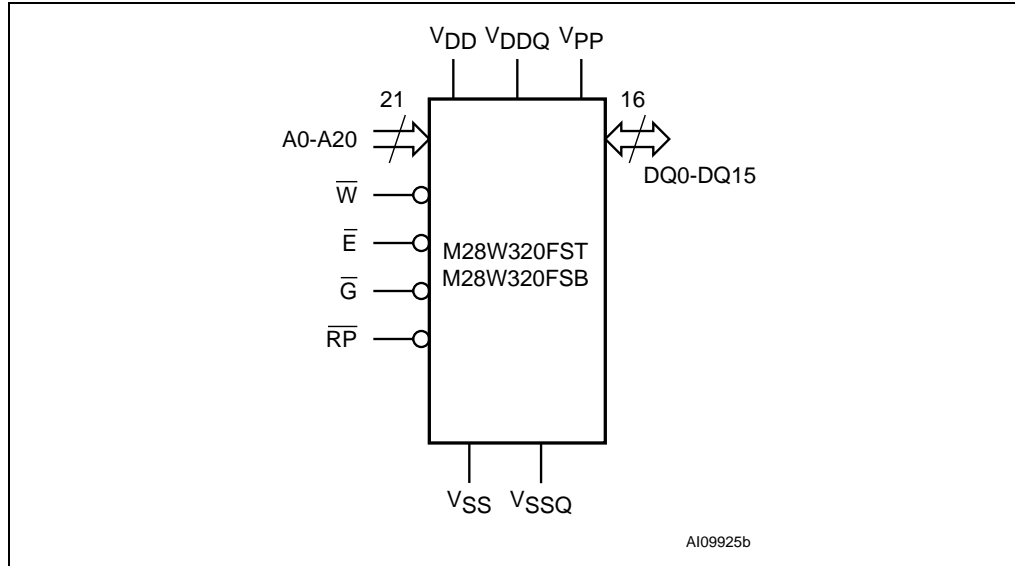

Figure 2. M28W640FS logic diagram

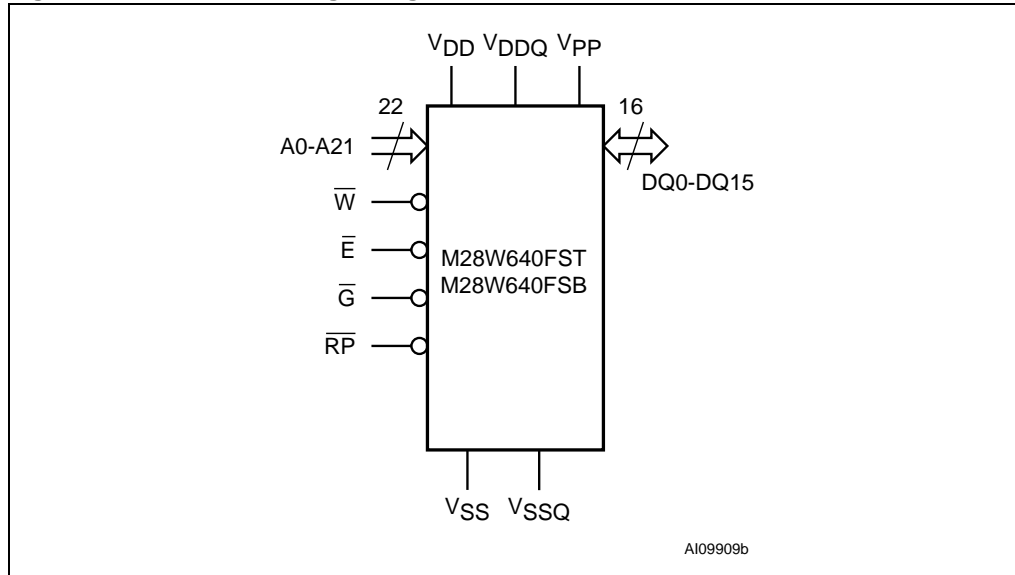

Figure 3. M28W320FSU logic diagram

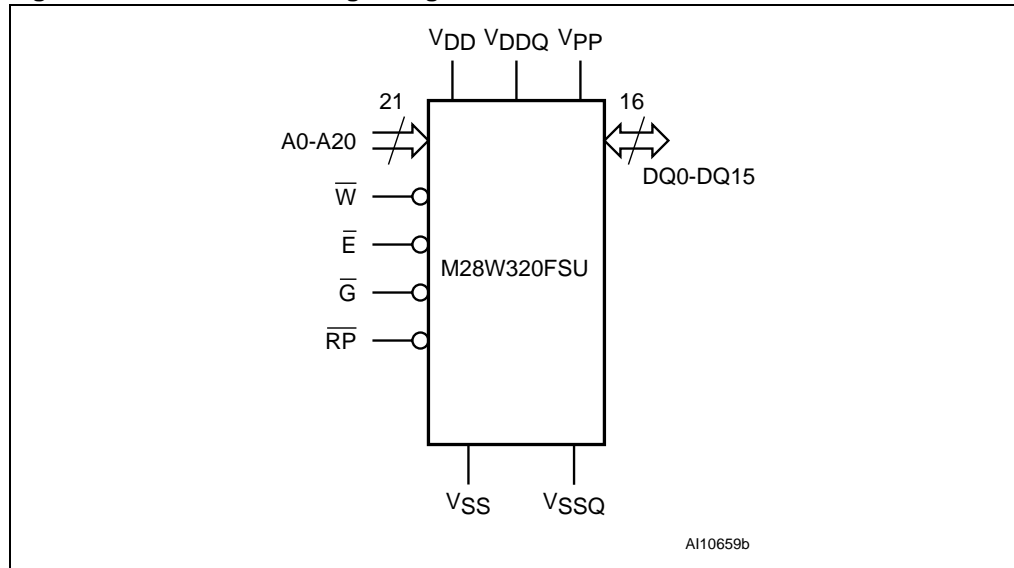

Figure 4. M28W640FSU logic diagram

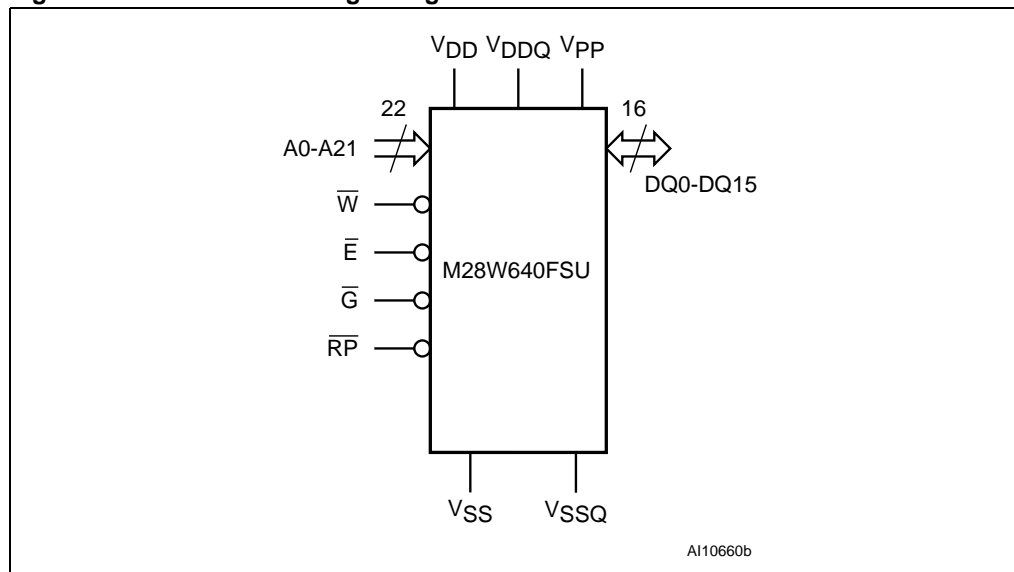
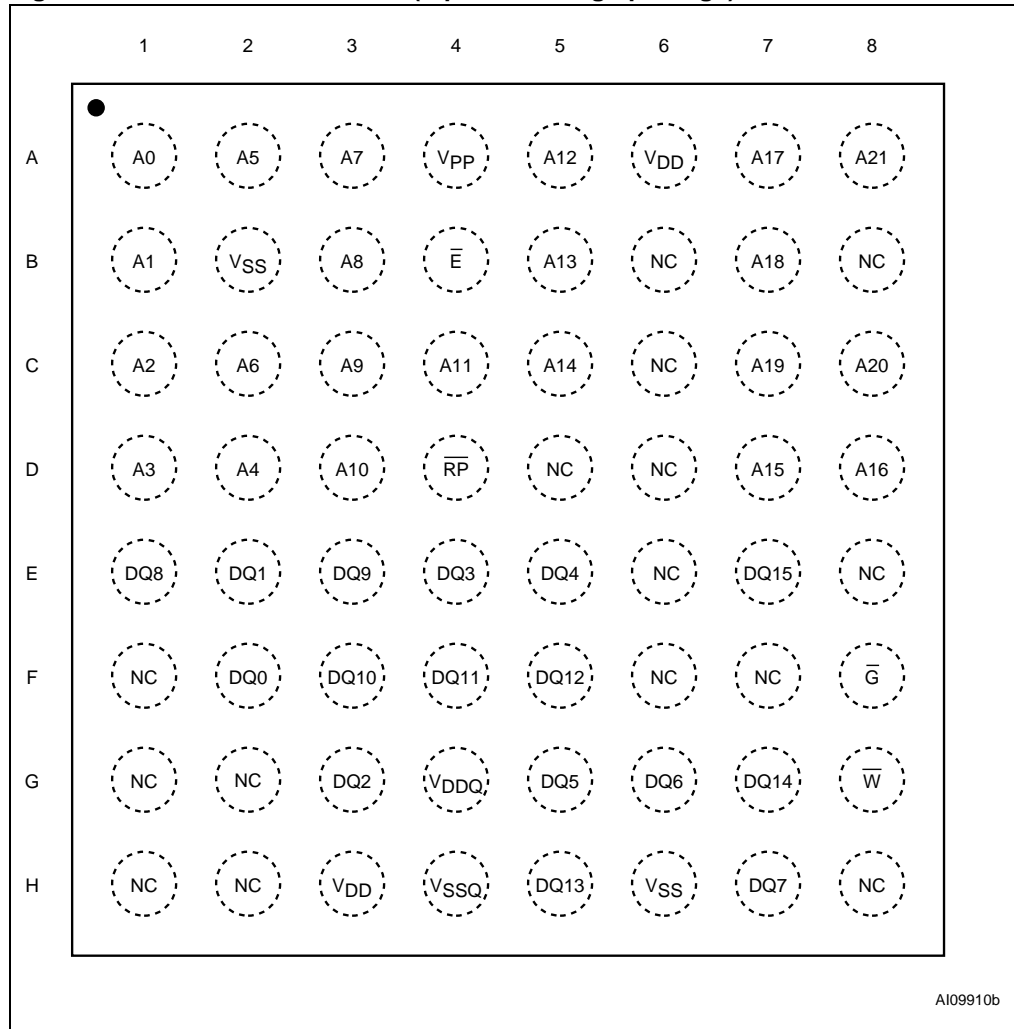
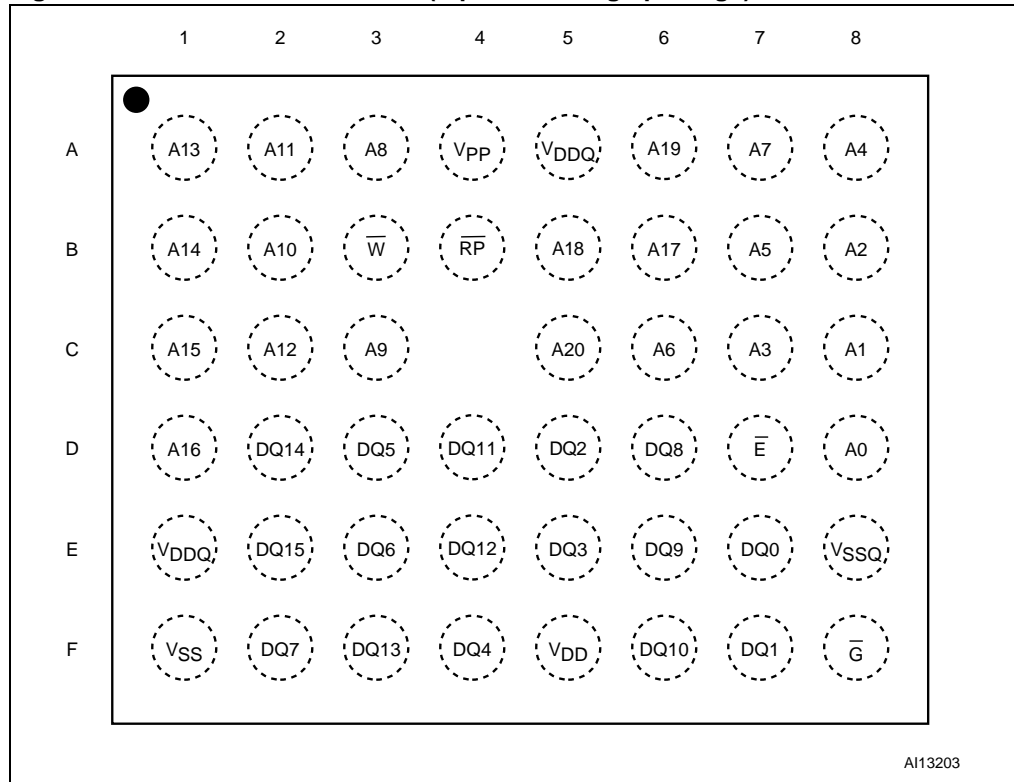

Figure 5. TBGA64 connections (top view through package)



- The above figure gives the TBGA connections for the M28W640FST, M28W640FSB and M28W640FSU. On the M28W320FST, M28W320FSB and M28W320FSU, A21 is NC.

Figure 6. TFBGA47 connections (top view through package)



1. The two V_{DDQ} balls (balls A5 and E1) must be connected to the power supply.
2. Only 32 Mbit devices are delivered in the TFBGA47 package.

Figure 7. M28W320FST and M28W320FSB block addresses

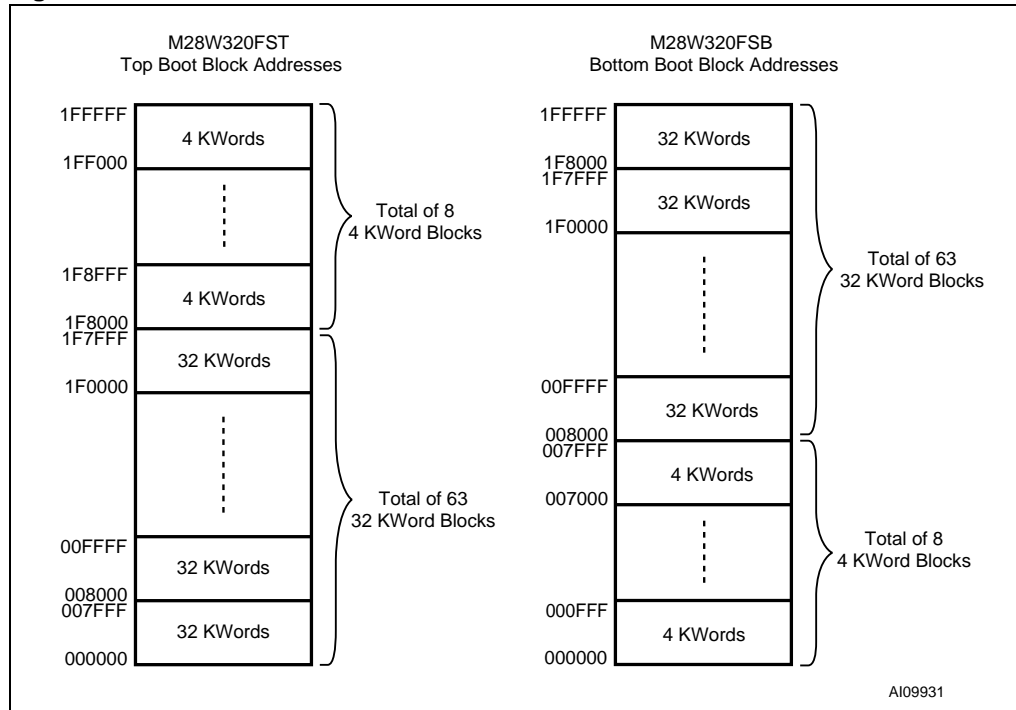

1. Also see [Appendix A, Table 22](#) and [Table 23](#) for a full listing of the Block Addresses.

Figure 8. M28W640FST and M28W640FSB block addresses

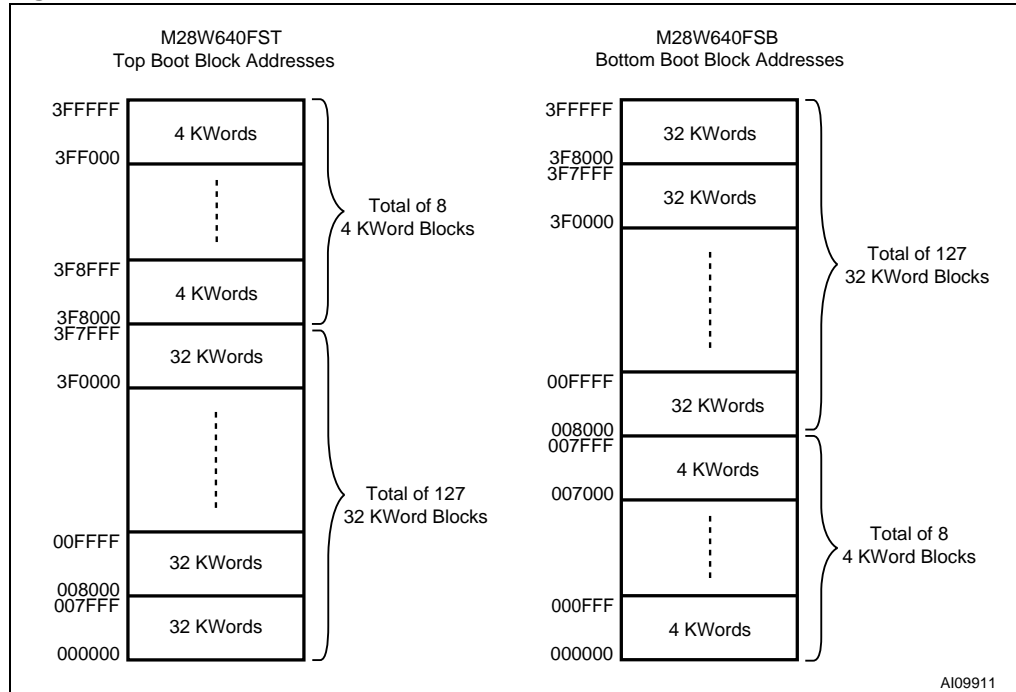

1. Also see [Appendix A, Table 24](#) and [Table 25](#) for a full listing of the Block Addresses.

Figure 9. M28W320FSU and M28W640FSU block addresses

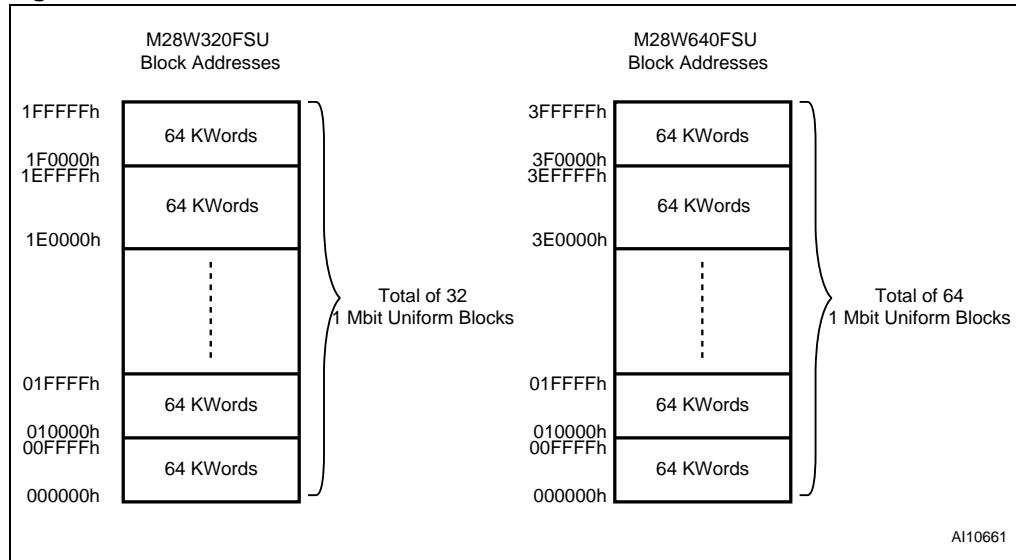

1. Also see [Appendix A, Table 26](#) and [Table 27](#) for a full listing of the Block Addresses.

Figure 10. Protection Register memory map

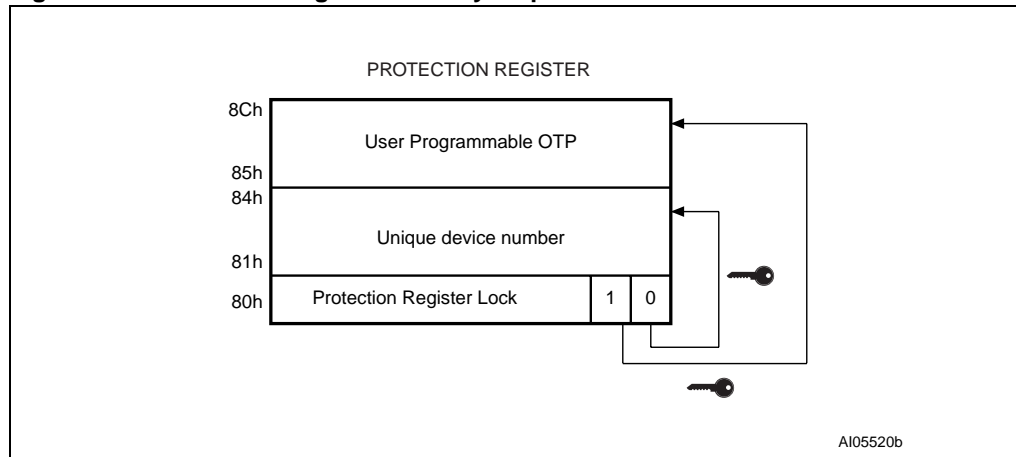

2 Signal descriptions

See [Figure 1](#), [Figure 2](#), [Figure 3](#), and [Figure 4](#), Logic Diagrams in conjunction with [Table 2: Signal names](#), for a brief overview of the signals connected to this devices.

2.1 Address Inputs

The Address Inputs select the cells in the memory array to access during Bus Read operations. Address Inputs range from A0 to A20 for the M28W320FS and M28W320FSU. The M28W640FS and M28W640FSU have an additional A21 address line. During Bus Write operations they control the commands sent to the Command Interface of the internal state machine.

2.2 Data Input/Output (DQ0-DQ15)

The Data I/O outputs the data stored at the selected address during a Bus Read operation or inputs a command or the data to be programmed during a Write Bus operation.

2.3 Chip Enable (\overline{E})

The Chip Enable input activates the memory control logic, input buffers, decoders and sense amplifiers. When Chip Enable is at V_{IL} and Reset is at V_{IH} the device is in active mode. When Chip Enable is at V_{IH} the memory is deselected, the outputs are high impedance and the power consumption is reduced to the stand-by level.

2.4 Output Enable (\overline{G})

The Output Enable controls data outputs during the Bus Read operation of the memory.

2.5 Write Enable (\overline{W})

The Write Enable controls the Bus Write operation of the memory's Command Interface. The data and address inputs are latched on the rising edge of Chip Enable, \overline{E} , or Write Enable, \overline{W} , whichever occurs first.

2.6 Reset (\overline{RP})

The Reset input provides a hardware reset of the memory. When Reset is at V_{IL} , the memory is in reset mode: the outputs are high impedance and the current consumption is minimized. After Reset all blocks are in the Locked state only if the volatile protection is activated. When Reset is at V_{IH} , the device is in normal operation. Exiting reset mode the device enters read array mode, but a negative transition of Chip Enable or a change of the address is required to ensure valid data outputs.

2.7 V_{DD} Supply Voltage

V_{DD} provides the power supply to the internal core of the memory device. It is the main power supply for all operations (Read, Program and Erase).

2.8 V_{DDQ} Supply Voltage

V_{DDQ} provides the power supply to the I/O pins and enables all Outputs to be powered independently from V_{DD} . V_{DDQ} can be tied to V_{DD} or can use a separate supply.

2.9 V_{PP} Program Supply Voltage

V_{PP} is both a control input and a power supply pin. The two functions are selected by the voltage range applied to the pin. The Supply Voltage V_{DD} and the Program Supply Voltage V_{PP} can be applied in any order.

If V_{PP} is kept in a low voltage range (0V to 3.6V), V_{PP} is seen as a control input. In this case a voltage lower than V_{PPLK} gives an absolute protection against program or erase, while $V_{PP} > V_{PP1}$ enables these functions (see [Table 14: DC characteristics](#), for the relevant values). V_{PP} is only sampled at the beginning of a program or erase; a change in its value after the operation has started does not have any effect on Program or Erase.

If V_{PP} is set to V_{PPH} , it acts as a power supply pin. In this condition V_{PP} must be stable until the Program/Erase algorithm is completed (see [Table 16](#) and [Table 17](#)). A Quadruple Word Program command will be ignored if V_{PP} is not set to V_{PPH} while a Double Word Program can be performed even if V_{PP} is set to V_{DD} .

2.10 V_{SS} Ground

V_{SS} is the reference for all voltage measurements.

2.11 V_{SSQ} Ground

V_{SSQ} ground is the reference for the input/output circuitry driven by V_{DDQ} . V_{SSQ} must be connected to V_{SS} .

Note: Each device in a system should have V_{DD} , V_{DDQ} and V_{PP} decoupled with a 0.1 μ F capacitor close to the pin. See [Figure 11: AC measurement load circuit](#). The PCB track widths should be sufficient to carry the required V_{PP} program and erase currents.

3 Bus operations

There are six standard bus operations that control the device. These are Bus Read, Bus Write, Output Disable, Standby, Automatic Standby and Reset. See [Table 3: Bus operations](#), for a summary.

Typically glitches of less than 5ns on Chip Enable or Write Enable are ignored by the memory and do not affect bus operations.

3.1 Read

Read Bus operations are used to output the contents of the Memory Array, the Electronic Signature, the Status Register and the Common Flash Interface. Both Chip Enable and Output Enable must be at V_{IL} in order to perform a read operation. The Chip Enable input should be used to enable the device. Output Enable should be used to gate data onto the output. The data read depends on the previous command written to the memory (see [Section 6: Command Interface](#)). See [Figure 12: Read ac waveforms](#), and [Table 15: Read ac characteristics](#), for details of when the output becomes valid.

Read mode is the default state of the device when exiting Reset or after power-up.

3.2 Write

Bus Write operations write Commands to the memory or latch Input Data to be programmed. A write operation is initiated when Chip Enable and Write Enable are at V_{IL} with Output Enable at V_{IH} . Commands, Input Data and Addresses are latched on the rising edge of Write Enable or Chip Enable, whichever occurs first.

See [Figure 13](#) and [Figure 14](#), Write AC Waveforms, and [Table 16](#) and [Table 17](#), Write AC Characteristics, for details of the timing requirements.

3.3 Output Disable

The data outputs are high impedance when the Output Enable is at V_{IH} .

3.4 Standby

Standby disables most of the internal circuitry allowing a substantial reduction of the current consumption. The memory is in stand-by when Chip Enable is at V_{IH} and the device is in read mode. The power consumption is reduced to the stand-by level and the outputs are set to high impedance, independently from the Output Enable or Write Enable inputs. If Chip Enable switches to V_{IH} during a program or erase operation, the device enters Standby mode when finished.

3.5 Automatic Standby

Automatic Standby provides a low power consumption state during Read mode. Following a read operation, the device enters Automatic Standby after 150ns of bus inactivity even if Chip Enable is Low, V_{IL} , and the supply current is reduced to I_{DD1} . The data Inputs/Outputs will still output data if a bus Read operation is in progress.

3.6 Reset

During Reset mode when Output Enable is Low, V_{IL} , the memory is deselected and the outputs are high impedance. The memory is in Reset mode when Reset is at V_{IL} . The power consumption is reduced to the Standby level, independently from the Chip Enable, Output Enable or Write Enable inputs. If Reset is pulled to V_{SS} during a Program or Erase, this operation is aborted and the memory content is no longer valid.

Table 3. Bus operations⁽¹⁾

Operation	\bar{E}	\bar{G}	\bar{W}	\bar{RP}	V_{PP}	DQ0-DQ15
Bus Read	V_{IL}	V_{IL}	V_{IH}	V_{IH}	Don't Care	Data Output
Bus Write	V_{IL}	V_{IH}	V_{IL}	V_{IH}	V_{DD} or V_{PPH}	Data Input
Output Disable	V_{IL}	V_{IH}	V_{IH}	V_{IH}	Don't Care	Hi-Z
Standby	V_{IH}	X	X	V_{IH}	Don't Care	Hi-Z
Reset	X	X	X	V_{IL}	Don't Care	Hi-Z

1. X = V_{IL} or V_{IH} , $V_{PPH} = 12V \pm 5\%$.

4 Hardware Protection

All devices feature hardware protection. Refer to [Section 2: Signal descriptions](#) for a detailed description of these signals.

All the memory blocks are protected from program or erase operations when V_{PP} is lower or equal to V_{PPLK} .

5 Security features

The M28W320FS, M28W640FS, M28W320FSU and M28W640FSU, are equipped with Krypto Security features performing software protection. They allow any block to be protected from program/erase or read operations:

- Modify Protection including Volatile Block Lock/Unlock, Non-Volatile Block Modify Protection, Non-Volatile Password Modify Protection and Irreversible Protection.
- Read Protection.

The Krypto features (Modify Protection mode, Read Protection mode and Device Authentication mechanism) are not described in this Datasheet. For further details concerning these additional protection modes please contact ST Sales Offices.

The devices also feature a 64 bit Unique Device Identifier and a 128 bit user-programmable OTP segment (see [Figure 10: Protection Register memory map](#) and [Section 6.12: Protection Register Program command](#)).

6 Command Interface

All Bus Write operations to the memory are interpreted by the Command Interface. Commands consist of one or more sequential Bus Write operations. An internal Program/Erase Controller handles all timings and verifies the correct execution of the Program and Erase commands. The Program/Erase Controller provides a Status Register whose output may be read at any time, to monitor the progress of the operation, or the Program/Erase states. See [Table 4: Command codes](#), for a summary of the commands and see [Appendix D, Table 34: Write State Machine Current/Next, sheet 1 of 2.](#), for a summary of the Command Interface.

The Command Interface is reset to Read mode when power is first applied, when exiting from Reset or whenever V_{DD} is lower than V_{LKO} . Command sequences must be followed exactly. Any invalid combination of commands will reset the device to Read mode. Refer to [Table 5: Commands](#), in conjunction with the text descriptions below.

6.1 Read Memory Array command

The Read command returns the memory to its Read mode. One Bus Write cycle is required to issue the Read Memory Array command and return the memory to Read mode. Subsequent read operations will read the addressed location and output the data. When a device Reset occurs, the memory defaults to Read mode.

6.2 Read Status Register command

The Status Register indicates when a program or erase operation is complete and the success or failure of the operation itself. Issue a Read Status Register command to read the Status Register's contents. Subsequent Bus Read operations read the Status Register at any address, until another command is issued. See [Table 9: Status Register bits](#), for details on the definitions of the bits.

The Read Status Register command may be issued at any time, even during a Program/Erase operation. Any Read attempt during a Program/Erase operation will automatically output the content of the Status Register.

6.3 Read Electronic Signature command

The Read Electronic Signature command reads the Manufacturer and Device Codes, and the Protection Register.

The Read Electronic Signature command consists of one write cycle, a subsequent read will output the Manufacturer Code, the Device Code and the Protection Register. See [Table 6](#), and [Table 7](#) for the valid address.

Table 4. Command codes

Hex Code	Command
10h or 40h	Program
20h	Erase
30h	Double Word Program
50h	Clear Status Register
56h	Quadruple Word Program
70h	Read Status Register
90h	Read Electronic Signature
98h	Read CFI Query
B0h	Program/Erase Suspend
C0h	Protection Register Program
D0h	Program/Erase Resume
FFh	Read Memory Array

6.4 Read CFI Query command

The Read Query Command is used to read data from the Common Flash Interface (CFI) Memory Area, allowing programming equipment or applications to automatically match their interface to the characteristics of the device. One Bus Write cycle is required to issue the Read Query Command. Once the command is issued subsequent Bus Read operations read from the Common Flash Interface Memory Area. See [Appendix B: Common Flash Interface \(CFI\)](#), [Table 28](#), [Table 29](#), [Table 30](#), [Table 31](#), [Table 32](#) and [Table 33](#) for details on the information contained in the Common Flash Interface memory area.

6.5 Block Erase command

The Block Erase command can be used to erase a block. It sets all the bits within the selected block to '1'. All previous data in the block is lost. If the block is protected then the Erase operation will abort, the data in the block will not be changed and the Status Register will output the error.

Two Bus Write cycles are required to issue the command:

- The first bus cycle sets up the Erase command.
- The second latches the block address in the internal state machine and starts the Program/Erase Controller.

If the second bus cycle is not Write Erase Confirm (D0h), Status Register bits b4 and b5 are set and the command aborts.

Erase aborts if Reset turns to V_{IL} . As data integrity cannot be guaranteed when the Erase operation is aborted, the block must be erased again.

During Erase operations the memory will accept the Read Status Register command and the Program/Erase Suspend command, all other commands will be ignored. Typical Erase times are given in [Table 8: Program/Erase times and endurance cycles](#).

See [Appendix C, Figure 22: Erase flowchart and pseudo code](#), for a suggested flowchart for using the Erase command.

6.6 Program command

The memory array can be programmed word-by-word. Two bus write cycles are required to issue the Program Command:

- The first bus cycle sets up the Program command.
- The second latches the Address and the Data to be written and starts the Program/Erase Controller.

During Program operations the memory will accept the Read Status Register command and the Program/Erase Suspend command. Typical Program times are given in [Table 8: Program/Erase times and endurance cycles](#).

Programming aborts if Reset goes to V_{IL} . As data integrity cannot be guaranteed when the program operation is aborted, the block containing the memory location must be erased and reprogrammed.

See [Appendix C, Table 18: Program flowchart and pseudo code](#), for the flowchart for using the Program command.

6.7 Double Word Program command

This feature is offered to improve the programming throughput, writing a page of two adjacent words in parallel. The two words must differ only for the address A0.

Three bus write cycles are necessary to issue the Double Word Program command:

- The first bus cycle sets up the Double Word Program Command.
- The second bus cycle latches the Address and the Data of the first word to be written.
- The third bus cycle latches the Address and the Data of the second word to be written and starts the Program/Erase Controller.

Read operations output the Status Register content after the programming has started. Programming aborts if Reset goes to V_{IL} . As data integrity cannot be guaranteed when the program operation is aborted, the block containing the memory location must be erased and reprogrammed.

See [Appendix C, Figure 19: Double Word Program flowchart and pseudo code](#) for the flowchart for using the Double Word Program command.

6.8 Quadruple Word Program command

This feature is offered to improve the programming throughput, writing a page of four adjacent words in parallel. The four words must differ only for the addresses A0 and A1.

A Quadruple word Program command will be ignored if V_{PP} is not set to V_{PPH} .

Five bus write cycles are necessary to issue the Quadruple Word Program command:

- The first bus cycle sets up the Quadruple Word Program Command.
- The second bus cycle latches the Address and the Data of the first word to be written.
- The third bus cycle latches the Address and the Data of the second word to be written.
- The fourth bus cycle latches the Address and the Data of the third word to be written.
- The fifth bus cycle latches the Address and the Data of the fourth word to be written and starts the Program/Erase Controller.

Read operations output the Status Register content after the programming has started. Programming aborts if Reset goes to V_{IL} . As data integrity cannot be guaranteed when the program operation is aborted, the block containing the memory location must be erased and reprogrammed.

See [Appendix C, Figure 20: Quadruple Word Program flowchart and pseudo code](#), for the flowchart for using the Quadruple Word Program command.

6.9 Clear Status Register command

The Clear Status Register command can be used to reset bits 1, 3, 4 and 5 in the Status Register to '0'. One bus write cycle is required to issue the Clear Status Register command.

The bits in the Status Register do not automatically return to '0' when a new Program or Erase command is issued. The error bits in the Status Register should be cleared before attempting a new Program or Erase command.

6.10 Program/Erase Suspend command

The Program/Erase Suspend command is used to pause a Program or Erase operation. One bus write cycle is required to issue the Program/Erase command and pause the Program/Erase controller.

During Program/Erase Suspend the Command Interface will accept the Program/Erase Resume, Read Array, Read Status Register, Read Electronic Signature and Read CFI Query commands. Additionally, if the suspend operation was Erase then the Program, Double Word Program, Quadruple Word Program or Block Lock commands will also be accepted. The block being erased may be protected by issuing the Block Protect or Block Lock commands. When the Program/Erase Resume command is issued the operation will complete. Only the blocks not being erased may be read or programmed correctly.

During a Program/Erase Suspend, the device can be placed in a pseudo-standby mode by taking Chip Enable to V_{IH} . Program/Erase is aborted if Reset turns to V_{IL} .

See [Appendix C, Figure 21: Program Suspend & Resume flowchart and pseudo code](#), and [Figure 23: Erase Suspend & Resume flowchart and pseudo code](#), for flowcharts for using the Program/Erase Suspend command.

6.11 Program/Erase Resume command

The Program/Erase Resume command can be used to restart the Program/Erase Controller after a Program/Erase Suspend operation has paused it. One Bus Write cycle is required to issue the command. Once the command is issued subsequent Bus Read operations read the Status Register.

See [Appendix C, Figure 21: Program Suspend & Resume flowchart and pseudo code](#), and [Figure 23: Erase Suspend & Resume flowchart and pseudo code](#), for flowcharts for using the Program/Erase Resume command.

6.12 Protection Register Program command

The Protection Register Program command is used to Program the 128 bit user One-Time-Programmable (OTP) segment of the Protection Register. The segment is programmed 16 bits at a time. When shipped all bits in the segment are set to '1'. The user can only program the bits to '0'.

Two write cycles are required to issue the Protection Register Program command.

- The first bus cycle sets up the Protection Register Program command.
- The second latches the Address and the Data to be written to the Protection Register and starts the Program/Erase Controller.

Read operations output the Status Register content after the programming has started.

The segment can be protected by programming bit 1 of the Protection Lock Register (see [Figure 10: Protection Register memory map](#)). Attempting to program a previously protected Protection Register will result in a Status Register error. The protection of the Protection Register is not reversible.

The Protection Register Program cannot be suspended.

Table 5. Commands

Commands	Cycles	Bus Write Operations ⁽¹⁾														
		1st Cycle			2nd Cycle			3rd Cycle			4th Cycle			5th Cycle		
		Op.	Add	Data	Op.	Add	Data	Op.	Add	Data	Op.	Add	Data	Op.	Add	Data
Read Memory Array	1+	Write	X	FFh	Read	RA	RD									
Read Status Register	1+	Write	X	70h	Read	X	SRD									
Read Electronic Signature	1+	Write	X	90h	Read	SA ⁽²⁾	IDh									
Read CFI Query	1+	Write	X	98h	Read	QA	QD									
Erase	2	Write	X	20h	Write	BA	D0h									
Program	2	Write	X	40h or 10h	Write	PA	PD									
Double Word Program ⁽³⁾	3	Write	X	30h	Write	PA1	PD1	Write	PA2	PD2						
Quadruple Word Program ⁽⁴⁾	5	Write	X	56h	Write	PA1	PD1	Write	PA2	PD2	Write	PA3	PD3	Write	PA4	PD4
Clear Status Register	1	Write	X	50h												
Program/Erase Suspend	1	Write	X	B0h												
Program/Erase Resume	1	Write	X	D0h												
Protection Register Program	2	Write	X	C0h	Write	PRA	PRD									

1. X = Don't Care, RA = Read Address, RD = Read Data, SRD = Status Register Data, ID = Identifier (Manufacture and Device Code), QA = Query Address, QD = Query Data, BA = Block Address, PA = Program Address, PD = Program Data, PRA = Protection Register Address, PRD = Protection Register Data.

2. The signature addresses are listed in [Table 6](#) and [Table 7](#).

3. Program Addresses 1 and 2 must be consecutive Addresses differing only for A0.

4. Program Addresses 1,2,3 and 4 must be consecutive Addresses differing only for A0 and A1.

Table 6. Read Electronic Signature

Code ⁽¹⁾	Device	\bar{E}	\bar{G}	\bar{W}	A0	A1	A2-A7	A8-A20 A8-A21 ⁽²⁾	DQ0-DQ7	DQ8-DQ15
Manufacture Code	All	V _{IL}	V _{IL}	V _{IH}	V _{IL}	V _{IL}	0	Don't Care	20h	00h
Device Code	M28W320FST	V _{IL}	V _{IL}	V _{IH}	V _{IH}	V _{IL}	0	Don't Care	0Ah	88h
Device Code	M28W320FSB	V _{IL}	V _{IL}	V _{IH}	V _{IH}	V _{IL}	0	Don't Care	0Bh	88h
	M28W640FST	V _{IL}	V _{IL}	V _{IH}	V _{IH}	V _{IL}	0	Don't Care	58h	88h
	M28W640FSB	V _{IL}	V _{IL}	V _{IH}	V _{IH}	V _{IL}	0	Don't Care	59h	88h
	M28W320FSU	V _{IL}	V _{IL}	V _{IH}	V _{IH}	V _{IL}	0	Don't Care	0Ch	88h
	M28W640FSU	V _{IL}	V _{IL}	V _{IH}	V _{IH}	V _{IL}	0	Don't Care	57h	88h

1. $\bar{R}\bar{P} = V_{IH}$.

2. Addresses range from A0 to A20 for the M28W320FS and M28W320FSU, and from A0 to A21 for the M28W640FS and the M28W640FSU.

Table 7. Read Protection Register and Protection Register Lock

Word	\bar{E}	\bar{G}	\bar{W}	A0-A7	A8-A21 ⁽¹⁾	DQ0	DQ1	DQ2	DQ3-DQ7	DQ8-DQ15
Lock	V _{IL}	V _{IL}	V _{IH}	80h	Don't Care	0	OTP Prot. data	0	00h	00h
Unique ID 0	V _{IL}	V _{IL}	V _{IH}	81h	Don't Care	ID data	ID data	ID data	ID data	ID data
Unique ID 1	V _{IL}	V _{IL}	V _{IH}	82h	Don't Care	ID data	ID data	ID data	ID data	ID data
Unique ID 2	V _{IL}	V _{IL}	V _{IH}	83h	Don't Care	ID data	ID data	ID data	ID data	ID data
Unique ID 3	V _{IL}	V _{IL}	V _{IH}	84h	Don't Care	ID data	ID data	ID data	ID data	ID data
OTP 0	V _{IL}	V _{IL}	V _{IH}	85h	Don't Care	OTP data	OTP data	OTP data	OTP data	OTP data
OTP 1	V _{IL}	V _{IL}	V _{IH}	86h	Don't Care	OTP data	OTP data	OTP data	OTP data	OTP data
OTP 2	V _{IL}	V _{IL}	V _{IH}	87h	Don't Care	OTP data	OTP data	OTP data	OTP data	OTP data
OTP 3	V _{IL}	V _{IL}	V _{IH}	88h	Don't Care	OTP data	OTP data	OTP data	OTP data	OTP data
OTP 4	V _{IL}	V _{IL}	V _{IH}	89h	Don't Care	OTP data	OTP data	OTP data	OTP data	OTP data
OTP 5	V _{IL}	V _{IL}	V _{IH}	8Ah	Don't Care	OTP data	OTP data	OTP data	OTP data	OTP data
OTP 6	V _{IL}	V _{IL}	V _{IH}	8Bh	Don't Care	OTP data	OTP data	OTP data	OTP data	OTP data
OTP 7	V _{IL}	V _{IL}	V _{IH}	8Ch	Don't Care	OTP data	OTP data	OTP data	OTP data	OTP data

1. Addresses range from A0 to A20 for the M28W320FS and M28W320FSU, and from A0 to A21 for the M28W640FS and the M28W640FSU.

Table 8. Program/Erase times and endurance cycles

Parameter			Test Conditions	Value			Unit
				Min	Typ	Max	
Word Program			$V_{PP} = V_{DD}$		10	200	μs
Double Word Program			$V_{PP} = V_{PPH}$ or $V_{PP} = V_{DD}$		10	200	μs
Quadruple Word Program			$V_{PP} = V_{PPH}$		10	200	μs
Block Program (M28W320FS, M28W640FS)	Main Block Program	Using Word Program command	$V_{PP} = V_{DD}$		0.32	5	s
		Using Double Word Program command	$V_{PP} = V_{PPH}$ or $V_{PP} = V_{DD}$		0.16		s
		Using Quadruple Word Program command	$V_{PP} = V_{PPH}$		0.08		s
	Parameter Block Program	Using Word Program command	$V_{PP} = V_{DD}$		0.04	4	s
		Using Double Word Program command	$V_{PP} = V_{PPH}$ or $V_{PP} = V_{DD}$		0.02		s
		Using Quadruple Word Program command	$V_{PP} = V_{PPH}$		0.01		
Block Program (M28W320FSU, M28W640FSU)		Using Word Program command	$V_{PP} = V_{DD}$		0.64	5	s
		Using Double Word Program command	$V_{PP} = V_{PPH}$ or $V_{PP} = V_{DD}$		0.32		s
		Using Quadruple Word Program command	$V_{PP} = V_{PPH}$		0.16		s
Block Erase (M28W320FS, M28W640FS)	Main Block Erase		$V_{PP} = V_{DD}$		1	10	s
			$V_{PP} = V_{PPH}$		1	10	s
	Parameter Block Erase		$V_{PP} = V_{PPH}$		0.4	10	s
			$V_{PP} = V_{DD}$		0.4	10	s
Block Erase (M28W320FSU, M28W640FSU)			$V_{PP} = V_{PPH}$ or $V_{PP} = V_{DD}$		1	10	s
Program/Erase Cycles (per Block)				100,000			cycles
Data Retention				20			years

7 Status Register

The Status Register provides information on the current or previous Program or Erase operation. The various bits convey information and errors on the operation. To read the Status register the Read Status Register command can be issued, refer to Read Status Register Command section. To output the contents, the Status Register is latched on the falling edge of the Chip Enable or Output Enable signals, and can be read until Chip Enable or Output Enable returns to V_{IH} . Either Chip Enable or Output Enable must be toggled to update the latched data.

Bus Read operations from any address always read the Status Register during Program and Erase operations.

The bits in the Status Register are summarized in [Table 9: Status Register bits](#). Refer to [Table 9](#) in conjunction with the following text descriptions.

7.1 Program/Erase Controller Status (Bit 7)

The Program/Erase Controller Status bit indicates whether the Program/Erase Controller is active or inactive. When the Program/Erase Controller Status bit is Low (set to '0'), the Program/Erase Controller is active; when the bit is High (set to '1'), the Program/Erase Controller is inactive, and the device is ready to process a new command.

The Program/Erase Controller Status is Low immediately after a Program/Erase Suspend command is issued until the Program/Erase Controller pauses. After the Program/Erase Controller pauses the bit is High.

During Program, Erase, operations the Program/Erase Controller Status bit can be polled to find the end of the operation. Other bits in the Status Register should not be tested until the Program/Erase Controller completes the operation and the bit is High.

After the Program/Erase Controller completes its operation the Erase Status, Program Status, V_{PP} Status and Block Lock Status bits should be tested for errors.

7.2 Erase Suspend Status (Bit 6)

The Erase Suspend Status bit indicates that an Erase operation has been suspended or is going to be suspended. When the Erase Suspend Status bit is High (set to '1'), a Program/Erase Suspend command has been issued and the memory is waiting for a Program/Erase Resume command.

The Erase Suspend Status should only be considered valid when the Program/Erase Controller Status bit is High (Program/Erase Controller inactive). Bit 7 is set within 30 μ s of the Program/Erase Suspend command being issued therefore the memory may still complete the operation rather than entering the Suspend mode.

When a Program/Erase Resume command is issued the Erase Suspend Status bit returns Low.

7.3 Erase Status (Bit 5)

The Erase Status bit can be used to identify if the memory has failed to verify that the block has erased correctly. When the Erase Status bit is High (set to '1'), the Program/Erase Controller has applied the maximum number of pulses to the block and still failed to verify that the block has erased correctly. The Erase Status bit should be read once the Program/Erase Controller Status bit is High (Program/Erase Controller inactive).

Once set High, the Erase Status bit can only be reset Low by a Clear Status Register command or a hardware reset. If set High it should be reset before a new Program or Erase command is issued, otherwise the new command will appear to fail.

7.4 Program Status (Bit 4)

The Program Status bit is used to identify a Program failure. When the Program Status bit is High (set to '1'), the Program/Erase Controller has applied the maximum number of pulses to the byte and still failed to verify that it has programmed correctly. The Program Status bit should be read once the Program/Erase Controller Status bit is High (Program/Erase Controller inactive).

Once set High, the Program Status bit can only be reset Low by a Clear Status Register command or a hardware reset. If set High it should be reset before a new command is issued, otherwise the new command will appear to fail.

7.5 V_{PP} Status (Bit 3)

The V_{PP} Status bit can be used to identify an invalid voltage on the V_{PP} pin during Program and Erase operations. The V_{PP} pin is only sampled at the beginning of a Program or Erase operation. Indeterminate results can occur if V_{PP} becomes invalid during an operation.

When the V_{PP} Status bit is Low (set to '0'), the voltage on the V_{PP} pin was sampled at a valid voltage; when the V_{PP} Status bit is High (set to '1'), the V_{PP} pin has a voltage that is below the V_{PP} Lockout Voltage, V_{PPLK}, the memory is protected and Program and Erase operations cannot be performed.

Once set High, the V_{PP} Status bit can only be reset Low by a Clear Status Register command or a hardware reset. If set High it should be reset before a new Program or Erase command is issued, otherwise the new command will appear to fail.

7.6 Program Suspend Status (Bit 2)

The Program Suspend Status bit indicates that a Program operation has been suspended. When the Program Suspend Status bit is High (set to '1'), a Program/Erase Suspend command has been issued and the memory is waiting for a Program/Erase Resume command. The Program Suspend Status should only be considered valid when the Program/Erase Controller Status bit is High (Program/Erase Controller inactive). Bit 2 is set within 5μs of the Program/Erase Suspend command being issued therefore the memory may still complete the operation rather than entering the Suspend mode.

When a Program/Erase Resume command is issued the Program Suspend Status bit returns Low.

7.7 Block Protection Status (Bit 1)

The Block Protection Status bit can be used to identify if a Program or Erase operation has tried to modify the contents of a locked block.

When the Block Protection Status bit is High (set to '1'), a Program or Erase operation has been attempted on a locked block.

Once set High, the Block Protection Status bit can only be reset Low by a Clear Status Register command or a hardware reset. If set High it should be reset before a new command is issued, otherwise the new command will appear to fail.

7.8 Reserved (Bit 0)

Bit 0 of the Status Register is reserved. Its value must be masked.

Note: Refer to [Appendix C: Flowcharts and pseudo codes](#), for using the Status Register.

Table 9. Status Register bits

Bit	Name	Logic Level ⁽¹⁾	Definition
7	P/E.C. Status	'1'	Ready
		'0'	Busy
6	Erase Suspend Status	'1'	Suspended
		'0'	In progress or Completed
5	Erase Status	'1'	Erase Error
		'0'	Erase Success
4	Program Status	'1'	Program Error
		'0'	Program Success
3	V _{PP} Status	'1'	V _{PP} Invalid, Abort
		'0'	V _{PP} OK
2	Program Suspend Status	'1'	Suspended
		'0'	In Progress or Completed
1	Block Protection Status	'1'	Program/Erase on protected Block, Abort
		'0'	No operation to protected blocks
0	Reserved		

1. Logic level '1' is High, '0' is Low.

8 Maximum rating

Stressing the device above the rating listed in the Absolute Maximum Ratings table may cause permanent damage to the device. These are stress ratings only and operation of the device at these or any other conditions above those indicated in the Operating sections of this specification is not implied. Exposure to Absolute Maximum Rating conditions for extended periods may affect device reliability. Refer also to the STMicroelectronics SURE Program and other relevant quality documents.

Table 10. Absolute maximum ratings

Symbol	Parameter	Value		Unit
		Min	Max	
T_A	Ambient Operating Temperature ⁽¹⁾	- 40	85	°C
T_{BIAS}	Temperature Under Bias	- 40	125	°C
T_{STG}	Storage Temperature	- 55	155	°C
$V_{IO}^{(2)(3)}$	Input or Output Voltage	- 0.6	$V_{DDQ}+0.6$	V
V_{DD}, V_{DDQ}	Supply Voltage	- 0.6	4.1	V
V_{PP}	Program Voltage	- 0.6	13	V

1. Depends on range.
2. The minimum Input/Output voltage may undershoot to - 2 V for less than 20 ns during transitions.
3. The maximum voltage may overshoot to $V_{DD} + 2$ V for less than 20 ns during transitions.

9 DC and ac parameters

This section summarizes the operating and measurement conditions, and the dc and ac characteristics of the device. The parameters in the dc and ac characteristics Tables that follow, are derived from tests performed under the Measurement Conditions summarized in [Table 11: Operating and ac measurement conditions](#). Designers should check that the operating conditions in their circuit match the measurement conditions when relying on the quoted parameters.

Table 11. Operating and ac measurement conditions

Parameter	Value		Unit
	Min	Max	
V_{DD} Supply Voltage	2.7	3.6	V
V_{DDQ} Supply Voltage ($V_{DDQ} \leq V_{DD}$)	2.7	3.6	V
Ambient Operating Temperature	-40	85	°C
Load Capacitance (C_L)	50		pF
Input Rise and Fall Times		5	ns
Input Pulse Voltages	0 to V_{DDQ}		V
Input and Output Timing Ref. Voltages	$V_{DDQ}/2$		V

Table 12. AC measurement I/O waveform

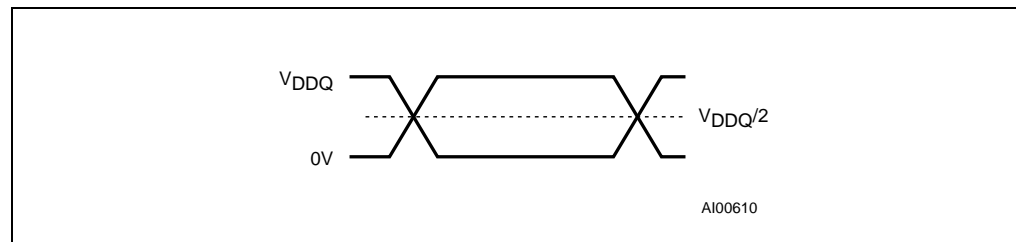

Figure 11. AC measurement load circuit

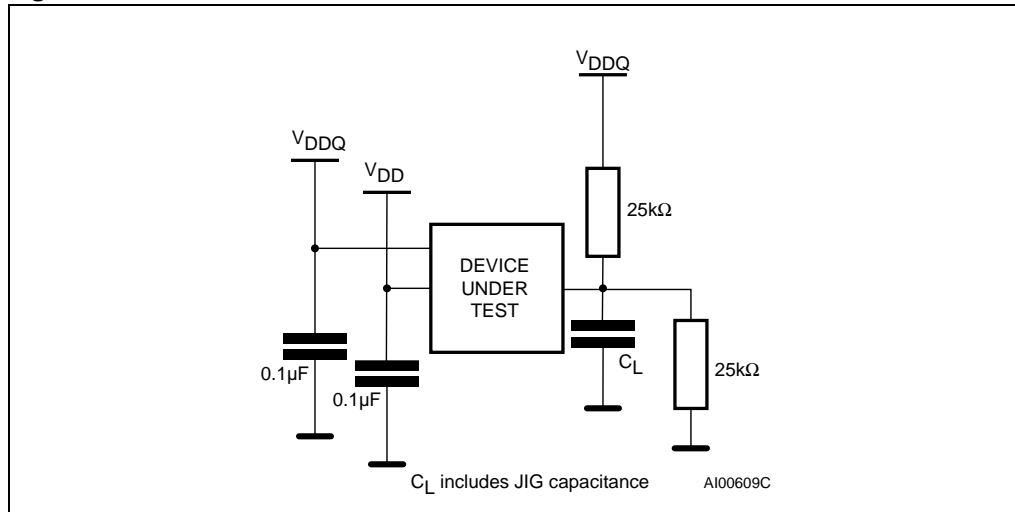

Table 13. Capacitance

Symbol	Parameter	Test condition	Min	Max ⁽¹⁾	Unit
C _{IN}	Input Capacitance	V _{IN} = 0 V		6	pF
C _{OUT}	Output Capacitance	V _{OUT} = 0 V		12	pF

1. Sampled only, not 100% tested.

Table 14. DC characteristics

Symbol	Parameter	Test condition	Min	Typ	Max	Unit
I_{LI}	Input Leakage Current	$0V \leq V_{IN} \leq V_{DDQ}$			± 1	μA
I_{LO}	Output Leakage Current	$0V \leq V_{OUT} \leq V_{DDQ}$			± 10	μA
I_{DD}	Supply Current (Read)	$\bar{E} = V_{SS}, \bar{G} = V_{IH},$ $f = 5 \text{ MHz}$		9	18	mA
I_{DD1}	Supply Current (Standby or Automatic Stand-by)	$\bar{E} = V_{DDQ} \pm 0.2 \text{ V},$ $\bar{RP} = V_{DDQ} \pm 0.2 \text{ V}$		15	50	μA
I_{DD2}	Supply Current (Reset)	$\bar{RP} = V_{SS} \pm 0.2 \text{ V}$		15	50	μA
I_{DD3}	Supply Current (Program)	Program in progress, $V_{PP} = 12 \text{ V} \pm 5\%$		5	10	mA
		Program in progress, $V_{PP} = V_{DD}$		10	20	mA
I_{DD4}	Supply Current (Erase)	Erase in progress, $V_{PP} = 12 \text{ V} \pm 5\%$		5	20	mA
		Erase in progress, $V_{PP} = V_{DD}$		10	20	mA
I_{DD5}	Supply Current (Program/Erase Suspend)	$\bar{E} = V_{DDQ} \pm 0.2 \text{ V},$ Erase suspended		15	50	μA
I_{PP}	Program Current (Read or Standby)	$V_{PP} > V_{DD}$			400	μA
I_{PP1}	Program Current (Read or Standby)	$V_{PP} \leq V_{DD}$		1	5	μA
I_{PP2}	Program Current (Reset)	$\bar{RP} = V_{SS} \pm 0.2 \text{ V}$		1	5	μA
I_{PP3}	Program Current (Program)	Program in progress, $V_{PP} = 12 \text{ V} \pm 5\%$		1	10	mA
		Program in progress, $V_{PP} = V_{DD}$		1	5	μA
I_{PP4}	Program Current (Erase)	Erase in progress $V_{PP} = 12 \text{ V} \pm 5\%$		3	10	mA
		Erase in progress $V_{PP} = V_{DD}$		1	5	μA
V_{IL}	Input Low Voltage		-0.5		0.8	V
V_{IH}	Input High Voltage		$0.7V_{DDQ}$		$V_{DDQ} + 0.4$	V
V_{OL}	Output Low Voltage	$I_{OL} = 100 \mu A, V_{DD} = V_{DDmin},$ $V_{DDQ} = V_{DDQmin}$			0.1	V
V_{OH}	Output High Voltage	$I_{OH} = -100 \mu A, V_{DD} = V_{DDmin},$ $V_{DDQ} = V_{DDQmin}$	$V_{DDQ} - 0.1$			V
V_{PP1}	Program Voltage (Program or Erase operations)		2.7		3.6	V
V_{PPH}	Program Voltage (Program or Erase operations)		11.4		12.6	V
V_{PPLK}	Program Voltage (Program and Erase lock-out)				1	V
V_{LKO}	V_{DD} Supply Voltage (Program and Erase lock-out)				2	V

Figure 12. Read ac waveforms

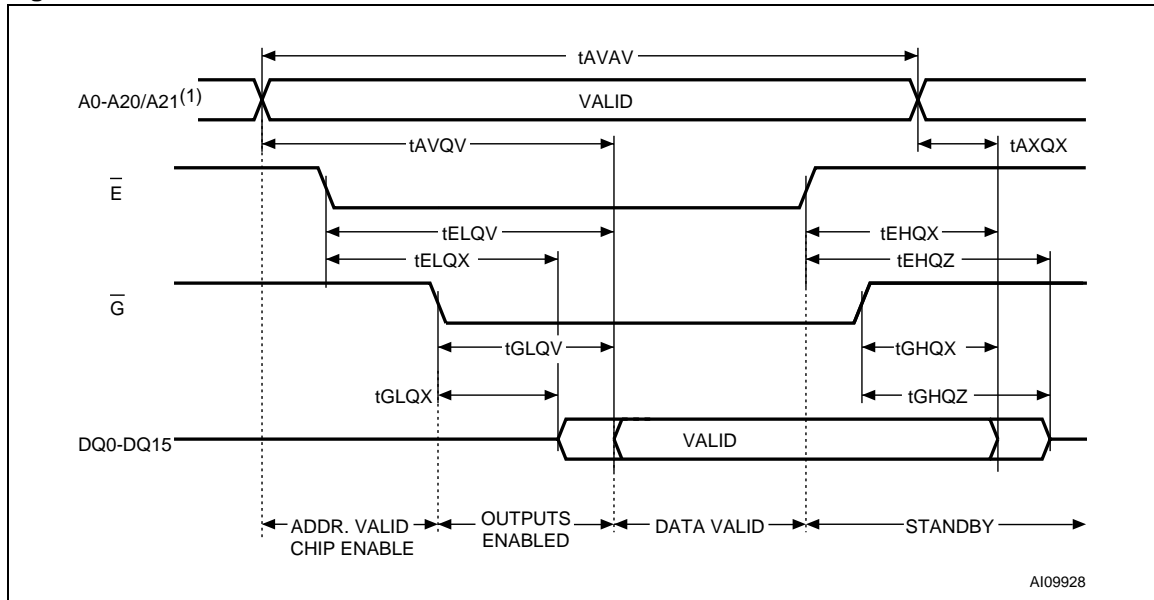

1. Addresses range from A0 to A20 for the M28W320FS and M28W320FSU, and from A0 to A21 for the M29W640FS and M28W640FSU.

Table 15. Read ac characteristics

Symbol	Alt	Parameter	Value	Unit
t_{AVAV}	t_{RC}	Address Valid to Next Address Valid	Min	70 ns
t_{AVQV}	t_{ACC}	Address Valid to Output Valid	Max	70 ns
$t_{AXQX}^{(1)}$	t_{OH}	Address Transition to Output Transition	Min	0 ns
$t_{EHQX}^{(1)}$	t_{OH}	Chip Enable High to Output Transition	Min	0 ns
$t_{EHQZ}^{(1)}$	t_{HZ}	Chip Enable High to Output Hi-Z	Max	20 ns
$t_{ELQV}^{(2)}$	t_{CE}	Chip Enable Low to Output Valid	Max	70 ns
$t_{ELQX}^{(1)}$	t_{LZ}	Chip Enable Low to Output Transition	Min	0 ns
$t_{GHQX}^{(1)}$	t_{OH}	Output Enable High to Output Transition	Min	0 ns
$t_{GHQZ}^{(1)}$	t_{DF}	Output Enable High to Output Hi-Z	Max	20 ns
$t_{GLQV}^{(2)}$	t_{OE}	Output Enable Low to Output Valid	Max	20 ns
$t_{GLQX}^{(1)}$	t_{OLZ}	Output Enable Low to Output Transition	Min	0 ns

1. Sampled only, not 100% tested.
 2. \bar{G} may be delayed by up to $t_{ELQV} - t_{GLQV}$ after the falling edge of \bar{E} without increasing t_{ELQV} .

Table 16. Write ac characteristics, Write Enable controlled

Symbol	Alt	Parameter		Value	Unit
t_{AVAV}	t_{WC}	Write cycle time	Min	70	ns
t_{AVWH}	t_{AS}	Address Valid to Write Enable High	Min	45	ns
t_{DVWH}	t_{DS}	Data Valid to Write Enable High	Min	45	ns
t_{ELWL}	t_{CS}	Chip Enable Low to Write Enable Low	Min	0	ns
t_{ELQV}		Chip Enable Low to Output Valid	Min	70	ns
$t_{QVPL}^{(1)(2)}$		Output Valid to V_{PP} Low	Min	0	ns
$t_{VPHWH}^{(1)}$	t_{VPS}	V_{PP} High to Write Enable High	Min	200	ns
t_{WHAX}	t_{AH}	Write Enable High to Address Transition	Min	0	ns
t_{WHDX}	t_{DH}	Write Enable High to Data Transition	Min	0	ns
t_{WHEH}	t_{CH}	Write Enable High to Chip Enable High	Min	0	ns
t_{WHEL}		Write Enable High to Chip Enable Low	Min	25	ns
t_{WHGL}		Write Enable High to Output Enable Low	Min	20	ns
t_{WHWL}	t_{WPH}	Write Enable High to Write Enable Low	Min	25	ns
t_{WLWH}	t_{WP}	Write Enable Low to Write Enable High	Min	45	ns

1. Sampled only, not 100% tested.
2. Applicable if V_{PP} is seen as a logic input ($V_{PP} < 3.6V$).

Figure 14. Write ac waveforms, Chip Enable controlled

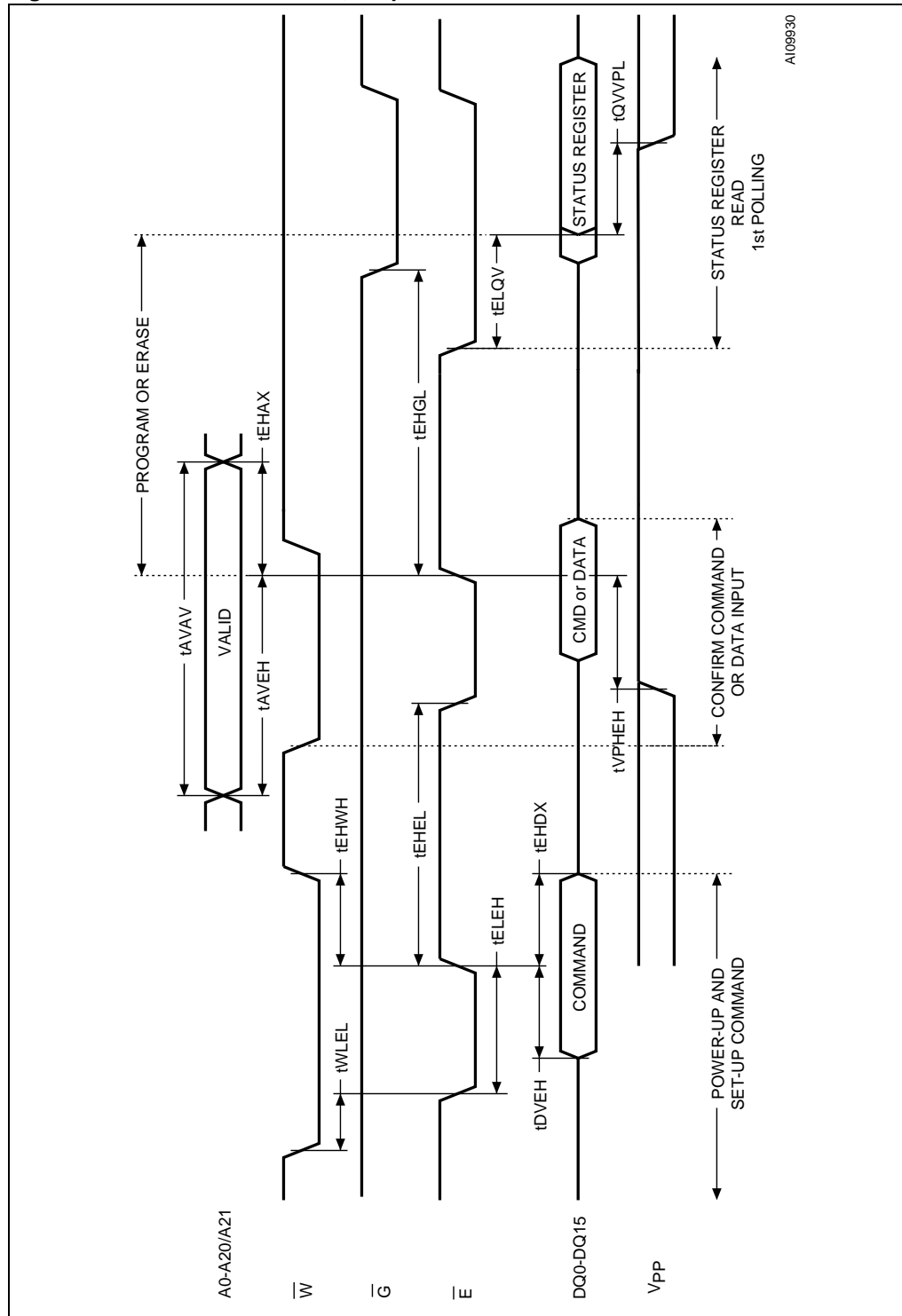

Note: 1. Addresses range from A0 to A20 for the M28W320FS and M28W320FSU, and from A0 to A21 for the M29W640FS and M28W640FSU.

Table 17. Write ac characteristics, Chip Enable controlled

Symbol	Alt	Parameter		Value	Unit
t_{AVAV}	t_{WC}	Write cycle time	Min	70	ns
t_{AVEH}	t_{AS}	Address Valid to Chip Enable High	Min	45	ns
t_{DVEH}	t_{DS}	Data Valid to Chip Enable High	Min	45	ns
t_{EHAX}	t_{AH}	Chip Enable High to Address Transition	Min	0	ns
t_{EHDX}	t_{DH}	Chip Enable High to Data Transition	Min	0	ns
t_{EHEL}	t_{CPH}	Chip Enable High to Chip Enable Low	Min	25	ns
t_{EHGL}		Chip Enable High to Output Enable Low	Min	25	ns
t_{EHWL}	t_{WH}	Chip Enable High to Write Enable High	Min	0	ns
t_{ELEH}	t_{CP}	Chip Enable Low to Chip Enable High	Min	45	ns
t_{ELQV}		Chip Enable Low to Output Valid	Min	70	ns
$t_{QVPL}^{(1)(2)}$		Output Valid to V_{PP} Low	Min	0	ns
$t_{VPHEH}^{(1)}$	t_{VPS}	V_{PP} High to Chip Enable High	Min	200	ns
t_{WLEL}	t_{CS}	Write Enable Low to Chip Enable Low	Min	0	ns

1. Sampled only, not 100% tested.
2. Applicable if V_{PP} is seen as a logic input ($V_{PP} < 3.6V$).

Figure 15. Power-Up and Reset ac waveforms

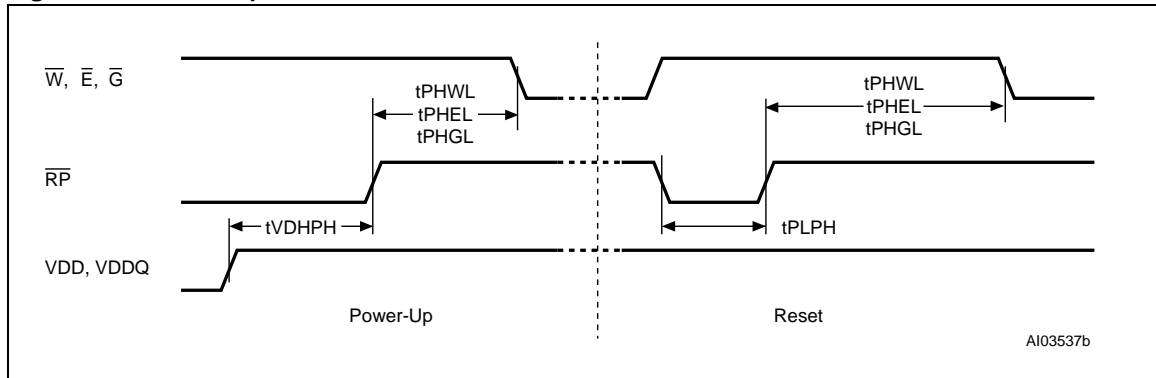

Table 18. Power-Up and Reset ac characteristics

Symbol	Parameter	Test condition		Value	Unit
t_{PHWL} t_{PHEL} t_{PHGL}	Reset High to Write Enable Low, Chip Enable Low, Output Enable Low	During Program and Erase	Min	50	μs
		others	Min	30	ns
$t_{PLPH}^{(1)(2)}$	Reset Low to Reset High		Min	100	ns
$t_{VDHPH}^{(3)}$	Supply Voltages High to Reset High		Min	50	μs

1. The device Reset is possible but not guaranteed if $t_{PLPH} < 100\text{ns}$.
2. Sampled only, not 100% tested.
3. It is important to assert \overline{RP} in order to allow proper CPU initialization during power up or reset.

10 Package mechanical

Figure 16. TBGA64 - 10 × 13 active ball array, 1 mm pitch, bottom view package outline

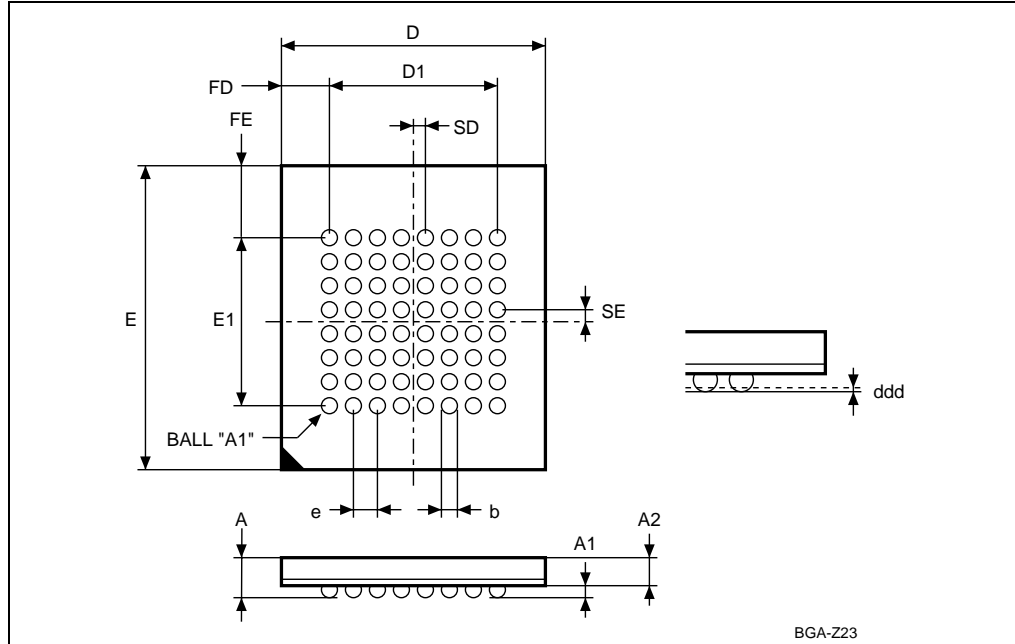

1. Drawing is not to scale.

Table 19. TBGA64 - 10 × 13 active ball array, 1 mm pitch, package mechanical data

Symbol	millimeters			inches		
	Typ	Min	Max	Typ	Min	Max
A			1.200			0.0472
A1	0.300	0.200	0.350	0.0118	0.0079	0.0138
A2	0.800			0.0315		
b		0.350	0.500		0.0138	0.0197
D	10.000	9.900	10.100	0.3937	0.3898	0.3976
D1	7.000	–	–	0.2756	–	–
ddd			0.100			0.0039
e	1.000	–	–	0.0394	–	–
E	13.000	12.900	13.100	0.5118	0.5079	0.5157
E1	7.000	–	–	0.2756	–	–
FD	1.500	–	–	0.0591	–	–
FE	3.000	–	–	0.1181	–	–
SD	0.500	–	–	0.0197	–	–
SE	0.500	–	–	0.0197	–	–

Figure 17. TFBGA47 - 8 × 6 active ball array, 0.75 mm pitch, view through package

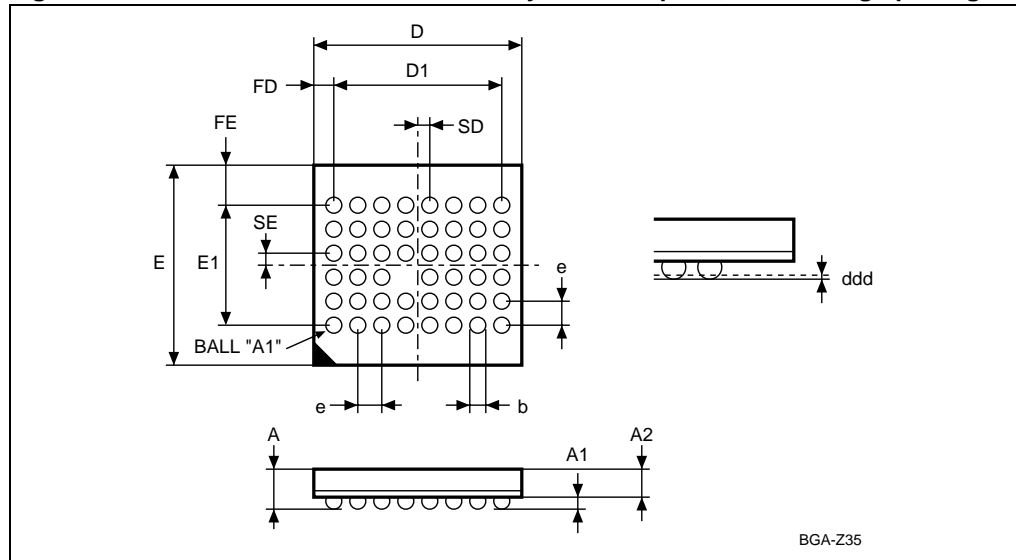

1. Drawing is not to scale.

Table 20. TFBGA47 - 8 × 6 active ball array, 0.75 mm pitch, package mechanical data

Symbol	millimeters			inches		
	Typ	Min	Max	Typ	Min	Max
A			1.200			0.0472
A1		0.200			0.0079	
A2			1.000			0.0394
b	0.400	0.350	0.450	0.0157	0.0138	0.0177
D	6.390	6.290	6.490	0.2516	0.2476	0.2555
D1	5.250	–	–	0.2067	–	–
ddd			0.100			0.0039
E	6.370	6.270	6.470	0.2508	0.2469	0.2547
E1	3.750	–	–	0.1476	–	–
e	0.750	–	–	0.0295	–	–
FD	0.570	–	–	0.0224	–	–
FE	1.310	–	–	0.0516	–	–
SD	0.375	–	–	0.0148	–	–
SE	0.375	–	–	0.0148	–	–

11 Part numbering

Table 21. Ordering information scheme

Example:	M28W320F	S	T	70	ZA	6	F
Device type							
M28							
Operating voltage							
W = $V_{DD} = 2.7\text{ V to }3.6\text{ V}$; $V_{DDQ} = 2.7\text{ V to }3.6\text{ V}$							
Density							
320F = 32 Mbit (2 Mb x16) 640F = 64 Mbit (4 Mb x16)							
Security							
S = Krypto™ Flash							
Memory block organization							
T = Top boot B = Bottom boot U = Uniform							
Speed							
70 = 70ns							
Package							
ZA = TBGA64:10 x 13 mm, 1 mm pitch ZB = TFBGA47, 6.39 x 6.37 mm, 0.75 mm pitch ⁽¹⁾							
Temperature Range							
1 = 0 to 70 °C 6 = -40 to 85 °C							
Option							
Blank = Standard Packing T = Tape & Reel Packing E = ECOPACK Package, Standard Packing F = ECOPACK Package, Tape & Reel Packing							
1. Available with 32 Mbit devices only.							

Note: *Devices are shipped from the factory with the memory content bits erased to '1'. For a list of available options (Speed, Package, etc.) or for further information on any aspect of this device, please contact the ST Sales Office nearest to you.*

Appendix A Block address tables

Table 22. Top Boot Block addresses, M28W320FST

#	Size (KWord)	Address Range
0	4	1FF000-1FFFFFF
1	4	1FE000-1FEFFF
2	4	1FD000-1FDFFF
3	4	1FC000-1FCFFF
4	4	1FB000-1FBFFF
5	4	1FA000-1FAFFF
6	4	1F9000-1F9FFF
7	4	1F8000-1F8FFF
8	32	1F0000-1F7FFF
9	32	1E8000-1EFFFF
10	32	1E0000-1E7FFF
11	32	1D8000-1DFFFF
12	32	1D0000-1D7FFF
13	32	1C8000-1CFFFF
14	32	1C0000-1C7FFF
15	32	1B8000-1BFFFF
16	32	1B0000-1B7FFF
17	32	1A8000-1AFFFF
18	32	1A0000-1A7FFF
19	32	198000-19FFFF
20	32	190000-197FFF
21	32	188000-18FFFF
22	32	180000-187FFF
23	32	178000-17FFFF
24	32	170000-177FFF
25	32	168000-16FFFF
26	32	160000-167FFF
27	32	158000-15FFFF
28	32	150000-157FFF
29	32	148000-14FFFF
30	32	140000-147FFF
31	32	138000-13FFFF
32	32	130000-137FFF
33	32	128000-12FFFF

Table 22. Top Boot Block addresses, M28W320FST (continued)

#	Size (KWord)	Address Range
34	32	120000-127FFF
35	32	118000-11FFFF
36	32	110000-117FFF
37	32	108000-10FFFF
38	32	100000-107FFF
39	32	0F8000-0FFFFF
40	32	0F0000-F7FFF
41	32	0E8000-0EFFFF
42	32	0E0000-0E7FFF
43	32	0D8000-0DFFFF
44	32	0D0000-0D7FFF
45	32	0C8000-0CFFFF
46	32	0C0000-0C7FFF
47	32	0B8000-0BFFFF
48	32	0B0000-0B7FFF
49	32	0A8000-0AFFFF
50	32	0A0000-0A7FFF
51	32	098000-09FFFF
52	32	090000-097FFF
53	32	088000-08FFFF
54	32	080000-087FFF
55	32	078000-07FFFF
56	32	070000-077FFF
57	32	068000-06FFFF
58	32	060000-067FFF
59	32	058000-05FFFF
60	32	050000-057FFF
61	32	048000-04FFFF
62	32	040000-047FFF
63	32	038000-03FFFF
64	32	030000-037FFF
65	32	028000-02FFFF
66	32	020000-027FFF
67	32	018000-01FFFF
68	32	010000-017FFF
69	32	008000-00FFFF
70	32	000000-007FFF

Table 23. Bottom Boot Block addresses, M28W320FSB

#	Size (KWord)	Address Range
70	32	1F8000-1FFFFFF
69	32	1F0000-1F7FFF
68	32	1E8000-1EFFFF
67	32	1E0000-1E7FFF
66	32	1D8000-1DFFFF
65	32	1D0000-1D7FFF
64	32	1C8000-1CFFFF
63	32	1C0000-1C7FFF
62	32	1B8000-1BFFFF
61	32	1B0000-1B7FFF
60	32	1A8000-1AFFFF
59	32	1A0000-1A7FFF
58	32	198000-19FFFF
57	32	190000-197FFF
56	32	188000-18FFFF
55	32	180000-187FFF
54	32	178000-17FFFF
53	32	170000-177FFF
52	32	168000-16FFFF
51	32	160000-167FFF
50	32	158000-15FFFF
49	32	150000-157FFF
48	32	148000-14FFFF
47	32	140000-147FFF
46	32	138000-13FFFF
45	32	130000-137FFF
44	32	128000-12FFFF
43	32	120000-127FFF
42	32	118000-11FFFF
41	32	110000-117FFF
40	32	108000-10FFFF
39	32	100000-107FFF
38	32	0F8000-0FFFFFF
37	32	0F0000-0F7FFF
36	32	0E8000-0EFFFF

Table 23. Bottom Boot Block addresses, M28W320FSB (continued)

#	Size (KWord)	Address Range
35	32	0E0000-0E7FFF
34	32	0D8000-0DFFFF
33	32	0D0000-0D7FFF
32	32	0C8000-0CFFFF
31	32	0C0000-0C7FFF
30	32	0B8000-0BFFFF
29	32	0B0000-0B7FFF
28	32	0A8000-0AFFFF
27	32	0A0000-0A7FFF
26	32	098000-09FFFF
25	32	090000-097FFF
24	32	088000-08FFFF
23	32	080000-087FFF
22	32	078000-07FFFF
21	32	070000-077FFF
20	32	068000-06FFFF
19	32	060000-067FFF
18	32	058000-05FFFF
17	32	050000-057FFF
16	32	048000-04FFFF
15	32	040000-047FFF
14	32	038000-03FFFF
13	32	030000-037FFF
12	32	028000-02FFFF
11	32	020000-027FFF
10	32	018000-01FFFF
9	32	010000-017FFF
8	32	008000-00FFFF
7	4	007000-007FFF
6	4	006000-006FFF
5	4	005000-005FFF
4	4	004000-004FFF
3	4	003000-003FFF
2	4	002000-002FFF
1	4	001000-001FFF
0	4	000000-000FFF

Table 24. Top Boot Block Addresses, M28W640FST

#	Size (KWord)	Address Range
0	4	3FF000-3FFFFFF
1	4	3FE000-3FEFFF
2	4	3FD000-3FDFFF
3	4	3FC000-3FCFFF
4	4	3FB000-3FBFFF
5	4	3FA000-3FAFFF
6	4	3F9000-3F9FFF
7	4	3F8000-3F8FFF
8	32	3F0000-3F7FFF
9	32	3E8000-3EFFFF
10	32	3E0000-3E7FFF
11	32	3D8000-3DFFFF
12	32	3D0000-3D7FFF
13	32	3C8000-3CFFFF
14	32	3C0000-3C7FFF
15	32	3B8000-3BFFFF
16	32	3B0000-3B7FFF
17	32	3A8000-3AFFFF
18	32	3A0000-3A7FFF
19	32	398000-39FFFF
20	32	390000-397FFF
21	32	388000-38FFFF
22	32	380000-387FFF
23	32	378000-37FFFF
24	32	370000-377FFF
25	32	368000-36FFFF
26	32	360000-367FFF
27	32	358000-35FFFF
28	32	350000-357FFF
29	32	348000-34FFFF
30	32	340000-347FFF
31	32	338000-33FFFF
32	32	330000-337FFF
33	32	328000-32FFFF
34	32	320000-327FFF

Table 24. Top Boot Block Addresses, M28W640FST (continued)

#	Size (KWord)	Address Range
35	32	318000-31FFFF
36	32	310000-317FFF
37	32	308000-30FFFF
38	32	300000-307FFF
39	32	2F8000-2FFFFF
40	32	2F0000-2F7FFF
41	32	2E8000-2EFFFF
42	32	2E0000-2E7FFF
43	32	2D8000-2DFFFF
44	32	2D0000-2D7FFF
45	32	2C8000-2CFFFF
46	32	2C0000-2C7FFF
47	32	2B8000-2BFFFF
48	32	2B0000-2B7FFF
49	32	2A8000-2AFFFF
50	32	2A0000-2A7FFF
51	32	298000-29FFFF
52	32	290000-297FFF
53	32	288000-28FFFF
54	32	280000-287FFF
55	32	278000-27FFFF
56	32	270000-277FFF
57	32	268000-26FFFF
58	32	260000-267FFF
59	32	258000-25FFFF
60	32	250000-257FFF
61	32	248000-24FFFF
62	32	240000-247FFF
63	32	238000-23FFFF
64	32	230000-237FFF
65	32	228000-22FFFF
66	32	220000-227FFF
67	32	218000-21FFFF
68	32	210000-217FFF
69	32	208000-20FFFF

Table 24. Top Boot Block Addresses, M28W640FST (continued)

#	Size (KWord)	Address Range
70	32	200000-207FFF
71	32	1F8000-1FFFFF
72	32	1F0000-1F7FFF
73	32	1E8000-1EFFFF
74	32	1E0000-1E7FFF
75	32	1D8000-1DFFFF
76	32	1D0000-1D7FFF
77	32	1C8000-1CFFFF
78	32	1C0000-1C7FFF
79	32	1B8000-1BFFFF
80	32	1B0000-1B7FFF
81	32	1A8000-1AFFFF
82	32	1A0000-1A7FFF
83	32	198000-19FFFF
84	32	190000-197FFF
85	32	188000-18FFFF
86	32	180000-187FFF
87	32	178000-17FFFF
88	32	170000-177FFF
89	32	168000-16FFFF
90	32	160000-167FFF
91	32	158000-15FFFF
92	32	150000-157FFF
93	32	148000-14FFFF
94	32	140000-147FFF
95	32	138000-13FFFF
96	32	130000-137FFF
97	32	128000-12FFFF
98	32	120000-127FFF
99	32	118000-11FFFF
100	32	110000-117FFF
101	32	108000-10FFFF
102	32	100000-107FFF
103	32	0F8000-0FFFFF
104	32	0F0000-0F7FFF

Table 24. Top Boot Block Addresses, M28W640FST (continued)

#	Size (KWord)	Address Range
105	32	0E8000-0EFFFF
106	32	0E0000-0E7FFF
107	32	0D8000-0DFFFF
108	32	0D0000-0D7FFF
109	32	0C8000-0CFFFF
110	32	0C0000-0C7FFF
111	32	0B8000-0BFFFF
112	32	0B0000-0B7FFF
113	32	0A8000-0AFFFF
114	32	0A0000-0A7FFF
115	32	098000-09FFFF
116	32	090000-097FFF
117	32	088000-08FFFF
118	32	080000-087FFF
119	32	078000-07FFFF
120	32	070000-077FFF
121	32	068000-06FFFF
122	32	060000-067FFF
123	32	058000-05FFFF
124	32	050000-057FFF
125	32	048000-04FFFF
126	32	040000-047FFF
127	32	038000-03FFFF
128	32	030000-037FFF
129	32	028000-02FFFF
130	32	020000-027FFF
131	32	018000-01FFFF
132	32	010000-017FFF
133	32	008000-00FFFF
134	32	000000-007FFF

Table 25. Bottom Boot Block addresses, M28W640FSB

#	Size (KWord)	Address Range
134	32	3F8000-3FFFFFF
133	32	3F0000-3F7FFF
132	32	3E8000-3EFFFF
131	32	3E0000-3E7FFF
130	32	3D8000-3DFFFF
129	32	3D0000-3D7FFF
128	32	3C8000-3CFFFF
127	32	3C0000-3C7FFF
126	32	3B8000-3BFFFF
125	32	3B0000-3B7FFF
124	32	3A8000-3AFFFF
123	32	3A0000-3A7FFF
122	32	398000-39FFFF
121	32	390000-397FFF
120	32	388000-38FFFF
119	32	380000-387FFF
118	32	378000-37FFFF
117	32	370000-377FFF
116	32	368000-36FFFF
115	32	360000-367FFF
114	32	358000-35FFFF
113	32	350000-357FFF
112	32	348000-34FFFF
111	32	340000-347FFF
110	32	338000-33FFFF
109	32	330000-337FFF
108	32	328000-32FFFF
107	32	320000-327FFF
106	32	318000-31FFFF
105	32	310000-317FFF
104	32	308000-30FFFF
103	32	300000-307FFF
102	32	2F8000-2FFFFFF
101	32	2F0000-2F7FFF
100	32	2E8000-2EFFFF

Table 25. Bottom Boot Block addresses, M28W640FSB (continued)

#	Size (KWord)	Address Range
99	32	2E0000-2E7FFF
98	32	2D8000-2DFFFF
97	32	2D0000-2D7FFF
96	32	2C8000-2CFFFF
95	32	2C0000-2C7FFF
94	32	2B8000-2BFFFF
93	32	2B0000-2B7FFF
92	32	2A8000-2AFFFF
91	32	2A0000-2A7FFF
90	32	298000-29FFFF
89	32	290000-297FFF
88	32	288000-28FFFF
87	32	280000-287FFF
86	32	278000-27FFFF
85	32	270000-277FFF
84	32	268000-26FFFF
83	32	260000-267FFF
82	32	258000-25FFFF
81	32	250000-257FFF
80	32	248000-24FFFF
79	32	240000-247FFF
78	32	238000-23FFFF
77	32	230000-237FFF
76	32	228000-22FFFF
75	32	220000-227FFF
74	32	218000-21FFFF
73	32	210000-217FFF
72	32	208000-20FFFF
71	32	200000-207FFF
70	32	1F8000-1FFFFF
69	32	1F0000-1F7FFF
68	32	1E8000-1EFFFF
67	32	1E0000-1E7FFF
66	32	1D8000-1DFFFF
65	32	1D0000-1D7FFF

Table 25. Bottom Boot Block addresses, M28W640FSB (continued)

#	Size (KWord)	Address Range
64	32	1C8000-1CFFFF
63	32	1C0000-1C7FFF
62	32	1B8000-1BFFFF
61	32	1B0000-1B7FFF
60	32	1A8000-1AFFFF
59	32	1A0000-1A7FFF
58	32	198000-19FFFF
57	32	190000-197FFF
56	32	188000-18FFFF
55	32	180000-187FFF
54	32	178000-17FFFF
53	32	170000-177FFF
52	32	168000-16FFFF
51	32	160000-167FFF
50	32	158000-15FFFF
49	32	150000-157FFF
48	32	148000-14FFFF
47	32	140000-147FFF
46	32	138000-13FFFF
45	32	130000-137FFF
44	32	128000-12FFFF
43	32	120000-127FFF
42	32	118000-11FFFF
41	32	110000-117FFF
40	32	108000-10FFFF
39	32	100000-107FFF
38	32	0F8000-0FFFFF
37	32	0F0000-0F7FFF
36	32	0E8000-0EFFFF
35	32	0E0000-0E7FFF
34	32	0D8000-0DFFFF
33	32	0D0000-0D7FFF
32	32	0C8000-0CFFFF
31	32	0C0000-0C7FFF
30	32	0B8000-0BFFFF

Table 25. Bottom Boot Block addresses, M28W640FSB (continued)

#	Size (KWord)	Address Range
29	32	0B0000-0B7FFF
28	32	0A8000-0AFFFF
27	32	0A0000-0A7FFF
26	32	098000-09FFFF
25	32	090000-097FFF
24	32	088000-08FFFF
23	32	080000-087FFF
22	32	078000-07FFFF
21	32	070000-077FFF
20	32	068000-06FFFF
19	32	060000-067FFF
18	32	058000-05FFFF
17	32	050000-057FFF
16	32	048000-04FFFF
15	32	040000-047FFF
14	32	038000-03FFFF
13	32	030000-037FFF
12	32	028000-02FFFF
11	32	020000-027FFF
10	32	018000-01FFFF
9	32	010000-017FFF
8	32	008000-00FFFF
7	4	007000-007FFF
6	4	006000-006FFF
5	4	005000-005FFF
4	4	004000-004FFF
3	4	003000-003FFF
2	4	002000-002FFF
1	4	001000-001FFF
0	4	000000-000FFF

Table 26. Block addresses, M28W320FSU

Block Number	Address Range
31	1F0000h-1FFFFFFh
30	1E0000h-1EFFFFh
29	1D0000h-1DFFFFh
28	1C0000h-1CFFFFh
27	1B0000h-1BFFFFh
26	1A0000h-1AFFFFh
25	190000h-19FFFFh
24	180000h-18FFFFh
23	170000h-17FFFFh
22	160000h-16FFFFh
21	150000h-15FFFFh
20	140000h-14FFFFh
19	130000h-13FFFFh
18	120000h-12FFFFh
17	110000h-11FFFFh
16	100000h-10FFFFh
15	0F0000h-0FFFFFFh
14	0E0000h-0EFFFFh
13	0D0000h-0DFFFFh
12	0C0000h-0CFFFFh
11	0B0000h-0BFFFFh
10	0A0000h-0AFFFFh
9	090000h-09FFFFh
8	080000h-08FFFFh
7	070000h-07FFFFh
6	060000h-06FFFFh
5	050000h-05FFFFh
4	040000h-04FFFFh
3	030000h-03FFFFh
2	020000h-02FFFFh
1	010000h-01FFFFh
0	000000h-00FFFFh

Table 27. Block addresses, M28W640FSU

Block Number	Address Range
63	3F0000h-3FFFFFFh
62	3E0000h-3EFFFFh
61	3D0000h-3DFFFFh
60	3C0000h-3CFFFFh
59	3B0000h-3BFFFFh
58	3A0000h-3AFFFFh
57	390000h-39FFFFh
56	380000h-38FFFFh
55	370000h-37FFFFh
54	360000h-36FFFFh
53	350000h-35FFFFh
52	340000h-34FFFFh
51	330000h-33FFFFh
50	320000h-32FFFFh
49	310000h-31FFFFh
48	300000h-30FFFFh
47	2F0000h-2FFFFFFh
46	2E0000h-2EFFFFh
45	2D0000h-2DFFFFh
44	2C0000h-2CFFFFh
43	2B0000h-2BFFFFh
42	2A0000h-2AFFFFh
41	290000h-29FFFFh
40	280000h-28FFFFh
39	270000h-27FFFFh
38	260000h-26FFFFh
37	250000h-25FFFFh
36	240000h-24FFFFh
35	230000h-23FFFFh
34	220000h-22FFFFh
33	210000h-21FFFFh
32	200000h-20FFFFh
31	1F0000h-1FFFFFFh
30	1E0000h-1EFFFFh
29	1D0000h-1DFFFFh

Table 27. Block addresses, M28W640FSU (continued)

Block Number	Address Range
28	1C0000h-1CFFFFh
27	1B0000h-1BFFFFh
26	1A0000h-1AFFFFh
25	190000h-19FFFFh
24	180000h-18FFFFh
23	170000h-17FFFFh
22	160000h-16FFFFh
21	150000h-15FFFFh
20	140000h-14FFFFh
19	130000h-13FFFFh
18	120000h-12FFFFh
17	110000h-11FFFFh
16	100000h-10FFFFh
15	0F0000h-0FFFFFh
14	0E0000h-0EFFFFh
13	0D0000h-0DFFFFh
12	0C0000h-0CFFFFh
11	0B0000h-0BFFFFh
10	0A0000h-0AFFFFh
9	090000h-09FFFFh
8	080000h-08FFFFh
7	070000h-07FFFFh
6	060000h-06FFFFh
5	050000h-05FFFFh
4	040000h-04FFFFh
3	030000h-03FFFFh
2	020000h-02FFFFh
1	010000h-01FFFFh
0	000000h-00FFFFh

Appendix B Common Flash Interface (CFI)

The Common Flash Interface is a JEDEC approved, standardized data structure that can be read from the Flash memory device. It allows a system software to query the device to determine various electrical and timing parameters, density information and functions supported by the memory. The system can interface easily with the device, enabling the software to upgrade itself when necessary.

When the CFI Query Command (RCFI) is issued the device enters CFI Query mode and the data structure is read from the memory. [Table 28](#), [Table 29](#), [Table 30](#), [Table 31](#), [Table 32](#) and [Table 33](#) show the addresses used to retrieve the data.

The CFI data structure also contains a security area where a 64 bit unique security number is written (see [Table 33: Security code area](#)). This area can be accessed only in Read mode by the final user. It is impossible to change the security number after it has been written by ST. Issue a Read command to return to Read mode.

Table 28. Query structure overview⁽¹⁾

Offset	Sub-section Name	Description
00h	Reserved	Reserved for algorithm-specific information
10h	CFI Query Identification String	Command set ID and algorithm data offset
1Bh	System Interface Information	Device timing & voltage information
27h	Device Geometry Definition	Flash device layout
P	Primary Algorithm-specific Extended Query table	Additional information specific to the Primary Algorithm (optional)
A	Alternate Algorithm-specific Extended Query table	Additional information specific to the Alternate Algorithm (optional)

1. Query data are always presented on the lowest order data outputs.

Table 29. CFI query identification string⁽¹⁾

Offset	Data	Description	Value
00h	0020h	Manufacturer Code	ST
01h	8858h	M28W640FST Device Code	Top
	880Ah	M28W320FST Device Code	
	8859h	M28W640FSB Device Code	Bottom
	880Bh	M28W320FSB Device Code	
01h	880Ch	M28W320FSU Device Code	Uniform
	8857h	M28W640FSU Device Code	
02h-0Fh	reserved	Reserved	
10h	0051h		"Q"
11h	0052h	Query Unique ASCII String "QRY"	"R"
12h	0059h		"Y"
13h	0003h	Primary Algorithm Command Set and Control Interface ID code 16 bit ID code defining a specific algorithm	Intel compatible
14h	0000h		
15h	0035h	Address for Primary Algorithm extended Query table (see Table 31)	P = 35h
16h	0000h		
17h	0000h	Alternate Vendor Command Set and Control Interface ID Code second vendor - specified algorithm supported (0000h means none exists)	NA
18h	0000h		
19h	0000h	Address for Alternate Algorithm extended Query table (0000h means none exists)	NA
1Ah	0000h		

1. Query data are always presented on the lowest order data outputs (DQ7-DQ0) only. DQ8-DQ15 are '0'.

Table 30. CFI query system interface information

Offset	Data	Description	Value
1Bh	0027h	V _{DD} Logic Supply Minimum Program/Erase or Write voltage bit 7 to 4 BCD value in volts bit 3 to 0 BCD value in 100mV	2.7V
1Ch	0036h	V _{DD} Logic Supply Maximum Program/Erase or Write voltage bit 7 to 4 BCD value in volts bit 3 to 0 BCD value in 100mV	3.6V
1Dh	00B4h	V _{PP} [Programming] Supply Minimum Program/Erase voltage bit 7 to 4 HEX value in volts bit 3 to 0 BCD value in 100mV	11.4V
1Eh	00C6h	V _{PP} [Programming] Supply Maximum Program/Erase voltage bit 7 to 4 HEX value in volts bit 3 to 0 BCD value in 100mV	12.6V
1Fh	0004h	Typical time-out per single word program = 2 ⁿ μs	16μs
20h	0004h	Typical time-out for Double/Quadruple Word Program = 2 ⁿ μs	16μs
21h	000Ah	Typical time-out per individual block erase = 2 ⁿ ms	1s
22h	0000h	Typical time-out for full chip erase = 2 ⁿ ms	NA
23h	0005h	Maximum time-out for Word program = 2 ⁿ times typical	512μs
24h	0005h	Maximum time-out for Double/Quadruple Word Program = 2 ⁿ times typical	512μs
25h	0003h	Maximum time-out per individual block erase = 2 ⁿ times typical	8s
26h	0000h	Maximum time-out for chip erase = 2 ⁿ times typical	NA

Table 31. Device geometry definition

Offset	Word Mode	Data	Description	Value
M28W320FST M28W320FSB M28W320FSU	27h	0016h	Device Size = 2 ⁿ in number of bytes	4 MByte
M28W640FST M28W640FSB M28W640FSU		0017h		8 MByte
28h 29h		0001h 0000h	Flash Device Interface Code description	x16 Async.
2Ah 2Bh		0003h 0000h	Maximum number of bytes in multi-byte program or page = 2 ⁿ	8
M28W320FSU M28W640FSU	2Ch	0001h	Number of Erase Block Regions within the device. It specifies the number of regions within the device containing contiguous Erase Blocks of the same size.	1
M28W320FST M28W320FSB M28W640FST M28W640FSB		0002h	Number of Erase Block Regions within the device. It specifies the number of regions within the device containing contiguous Erase Blocks of the same size.	2
M28W320FST	2Dh 2Eh	003Eh 0000h	Region 1 Information Number of identical-size erase block = 003Eh+1	63
	2Fh 30h	0000h 0001h	Region 1 Information Block size in Region 1 = 0100h * 256 byte	64 KByte
	31h 32h	0007h 0000h	Region 2 Information Number of identical-size erase block = 0007h+1	8
	33h 34h	0020h 0000h	Region 2 Information Block size in Region 2 = 0020h * 256 byte	8 KByte
M28W320FSB	2Dh 2Eh	0007h 0000h	Region 1 Information Number of identical-size erase block = 0007h+1	8
	2Fh 30h	0020h 0000h	Region 1 Information Block size in Region 1 = 0020h * 256 byte	8 KByte
	31h 32h	003Eh 0000h	Region 2 Information Number of identical-size erase block = 003Eh+1	63
	33h 34h	0000h 0001h	Region 2 Information Block size in Region 2 = 0100h * 256 byte	64 KByte

Table 31. Device geometry definition

Offset	Word Mode	Data	Description	Value
M28W320FSU	2Dh 2Eh	001Fh 0000h	Region 1 Information Number of identical-size erase blocks = 001Fh+1	32
	2Fh 30h	0000h 0002h	Region 1 Information Block size in Region 1 = 0200h * 256 byte	128 KBytes
	31h to 34h		Reserved	
M28W640FST	2Dh 2Eh	007Eh 0000h	Region 1 Information Number of identical-size erase block = 007Eh+1	127
	2Fh 30h	0000h 0001h	Region 1 Information Block size in Region 1 = 0100h * 256 byte	64 KByte
	31h 32h	0007h 0000h	Region 2 Information Number of identical-size erase block = 0007h+1	8
	33h 34h	0020h 0000h	Region 2 Information Block size in Region 2 = 0020h * 256 byte	8 KByte
M28W640FSB	2Dh 2Eh	0007h 0000h	Region 1 Information Number of identical-size erase block = 0007h+1	8
	2Fh 30h	0020h 0000h	Region 1 Information Block size in Region 1 = 0020h * 256 byte	8 KByte
	31h 32h	007Eh 0000h	Region 2 Information Number of identical-size erase block = 007Eh+1	127
	33h 34h	0000h 0001h	Region 2 Information Block size in Region 2 = 0100h * 256 byte	64 KByte
M28W640FSU	2Dh 2Eh	003Fh 0000h	Region 1 Information Number of identical-size erase blocks = 003Fh+1	64
	2Fh 30h	0000h 0002h	Region 1 Information Block size in Region 1 = 0200h * 256 byte	128 KBytes
	31h to 34h		Reserved	

Table 32. Primary algorithm-specific extended query table

Offset P = 35h ⁽¹⁾	Data	Description	Value
(P+0)h = 35h	0050h	Primary Algorithm extended Query table unique ASCII string "PRI"	"P"
(P+1)h = 36h	0052h		"R"
(P+2)h = 37h	0049h		"I"
(P+3)h = 38h	0031h	Major version number, ASCII	"1"
(P+4)h = 39h	0030h	Minor version number, ASCII	"0"
(P+5)h = 3Ah	0066h	Extended Query table contents for Primary Algorithm. Address (P+5)h contains less significant byte. bit 0 Chip Erase supported (1 = Yes, 0 = No) bit 1 Suspend Erase supported (1 = Yes, 0 = No) bit 2 Suspend Program supported (1 = Yes, 0 = No) bit 3 Legacy Lock/Unlock supported (1 = Yes, 0 = No) bit 4 Queued Erase supported (1 = Yes, 0 = No) bit 5 Instant individual block locking supported (1 = Yes, 0 = No) bit 6 Protection bits supported (1 = Yes, 0 = No) bit 7 Page mode read supported (1 = Yes, 0 = No) bit 8 Synchronous read supported (1 = Yes, 0 = No) bit 31 to 9 Reserved; undefined bits are '0'	No
(P+6)h = 3Bh	0000h		Yes
(P+7)h = 3Ch	0000h		Yes
(P+8)h = 3Dh	0000h		No No Yes Yes No No
(P+9)h = 3Eh	0001h	Supported Functions after Suspend Read Array, Read Status Register and CFI Query are always supported during Erase or Program operation bit 0 Program supported after Erase Suspend (1 = Yes, 0 = No) bit 7 to 1 Reserved; undefined bits are '0'	Yes
(P+A)h = 3Fh	0003h	Block Lock Status	Yes Yes
(P+B)h = 40h	0000h	Defines which bits in the Block Status Register section of the Query are implemented. Address (P+A)h contains less significant byte bit 0 Block Lock Status Register Lock/Unlock bit active (1 = Yes, 0 = No) bit 15 to 1 Reserved for future use; undefined bits are '0'	
(P+C)h = 41h	0030h	V _{DD} Logic Supply Optimum Program/Erase voltage (highest performance) bit 7 to 4 HEX value in volts bit 3 to 0 BCD value in 100mV	3V
(P+D)h = 42h	00C0h	V _{PP} Supply Optimum Program/Erase voltage bit 7 to 4 HEX value in volts bit 3 to 0 BCD value in 100mV	12V
(P+E)h = 43h	0001h	Number of Protection register fields in JEDEC ID space. "00h," indicates that 256 protection bytes are available	01

Table 32. Primary algorithm-specific extended query table (continued)

Offset P = 35h ⁽¹⁾	Data	Description	Value
(P+F)h = 44h	0080h	Protection Field 1: Protection Description This field describes user-available One Time Programmable (OTP) Protection Register bytes. Some are pre-programmed with device unique serial numbers. Others are user programmable. Bits 0–15 point to the Protection Register Lock byte, the section's first byte. The following bytes are factory pre-programmed and user-programmable. bit 0 to 7 Lock/bytes JEDEC-plane physical low address bit 8 to 15 Lock/bytes JEDEC-plane physical high address bit 16 to 23 "n" such that 2 ⁿ = factory pre-programmed bytes bit 24 to 31 "n" such that 2 ⁿ = user programmable bytes	80h
(P+10)h = 45h	0000h		00h
(P+11)h = 46h	0003h		8 Bytes
M28W320FST, M28W320FSB M28W320FSU M28W640FSU	(P+12)h = 47h		0003h
M28W640FST, M28W640FSB M28W320FSU M28W640FSU		0004h	16 Bytes
(P+13)h = 48h		Reserved	

1. See [Table 29](#), offset 15 for P pointer definition.

Table 33. Security code area

Offset	Data	Description
80h	00XX	Protection Register Lock
81h	XXXX	64 bits: unique device number
82h	XXXX	
83h	XXXX	
84h	XXXX	
85h	XXXX	128 bits: User Programmable OTP
86h	XXXX	
87h	XXXX	
88h	XXXX	
89h	XXXX	
8Ah	XXXX	
8Bh	XXXX	
8Ch	XXXX	

Appendix C Flowcharts and pseudo codes

Figure 18. Program flowchart and pseudo code

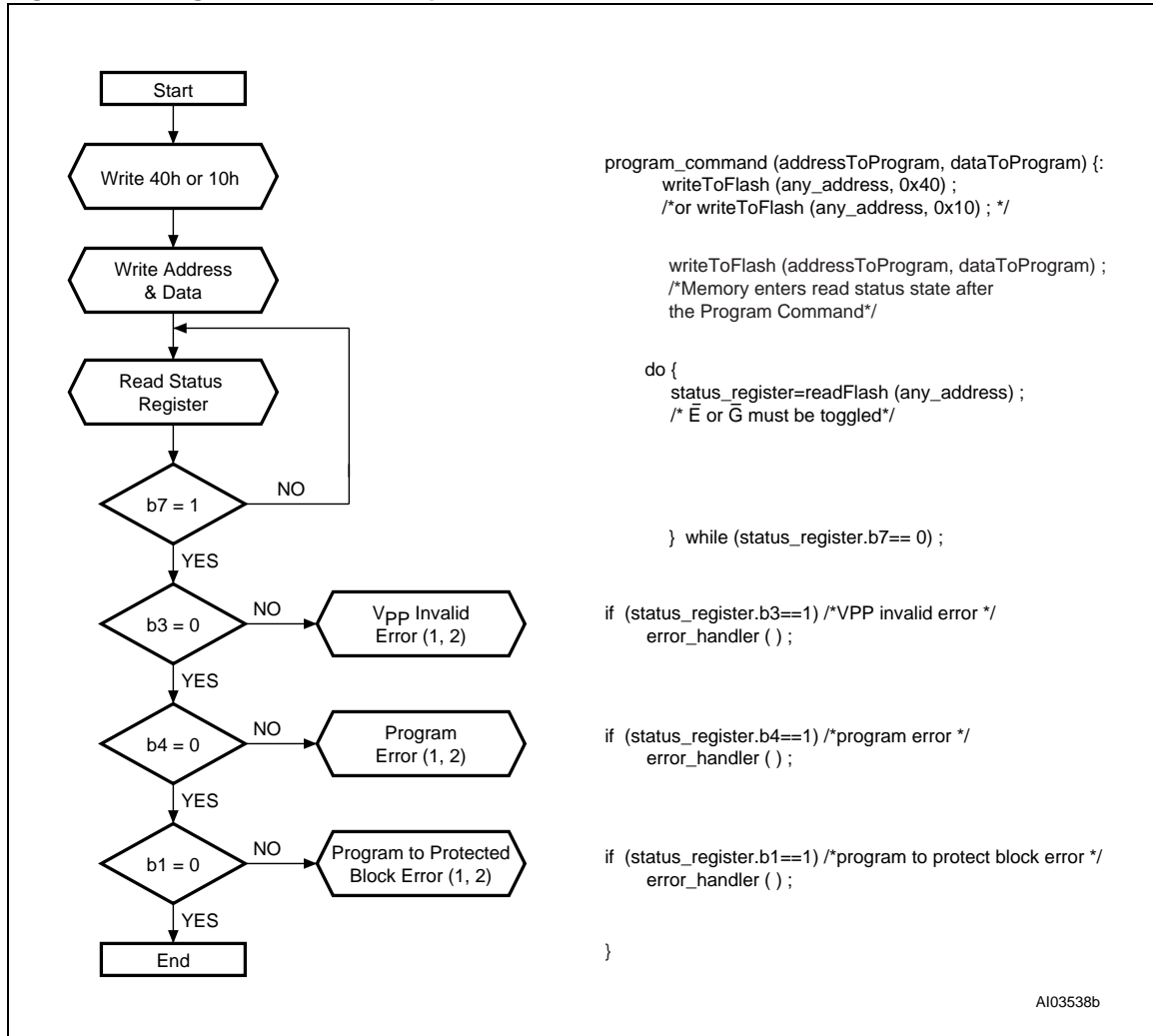

1. Status check of b1 (Protected Block), b3 (V_{PP} Invalid) and b4 (Program Error) can be made after each program operation or after a sequence.
1. If an error is found, the Status Register must be cleared before further Program/Erase Controller operations.

Figure 19. Double Word Program flowchart and pseudo code

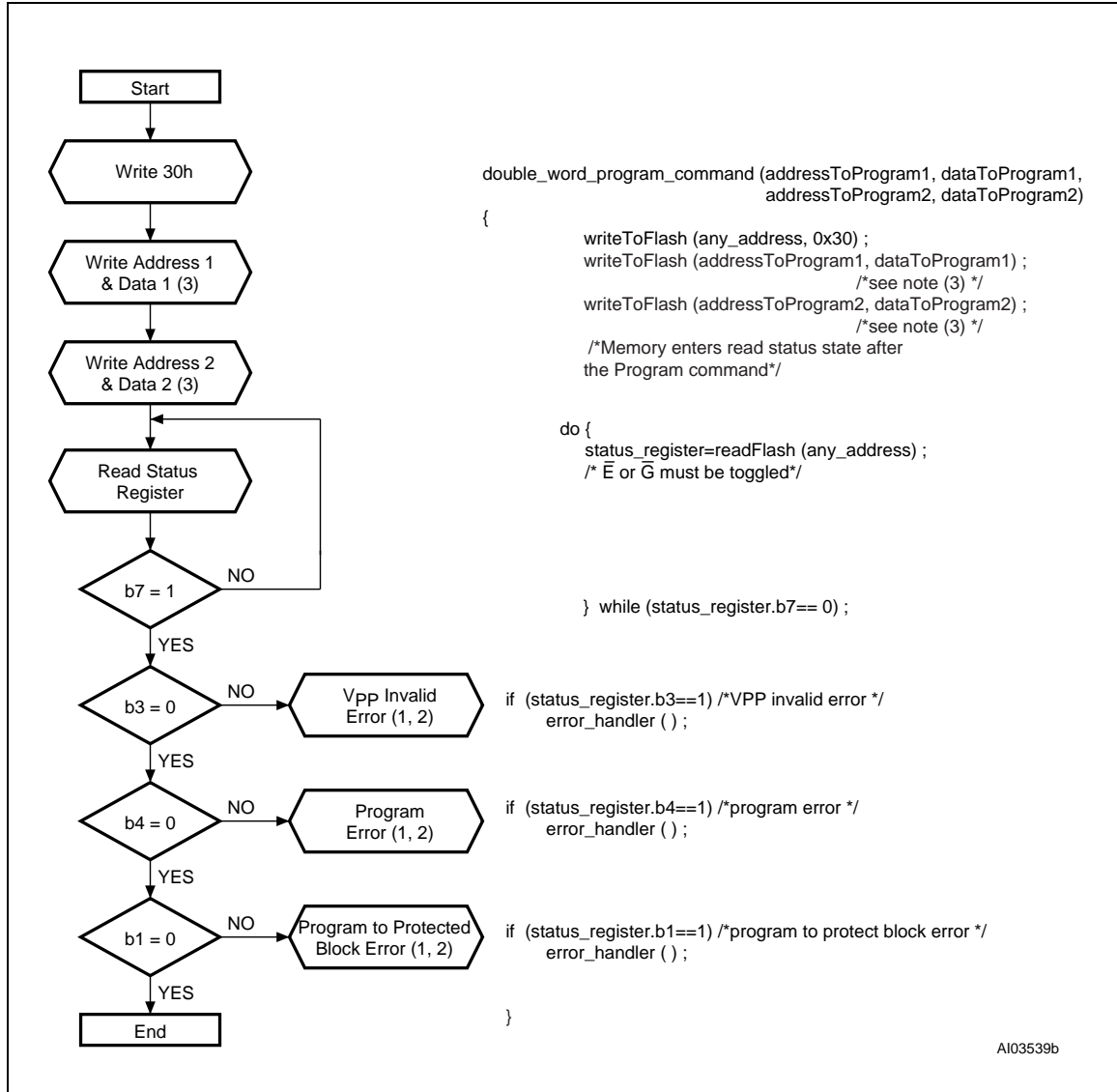

1. Status check of b1 (Protected Block), b3 (Vpp Invalid) and b4 (Program Error) can be made after each program operation or after a sequence.
2. If an error is found, the Status Register must be cleared before further Program/Erase operations.
3. Address 1 and Address 2 must be consecutive addresses differing only for bit A0.

Figure 20. Quadruple Word Program flowchart and pseudo code

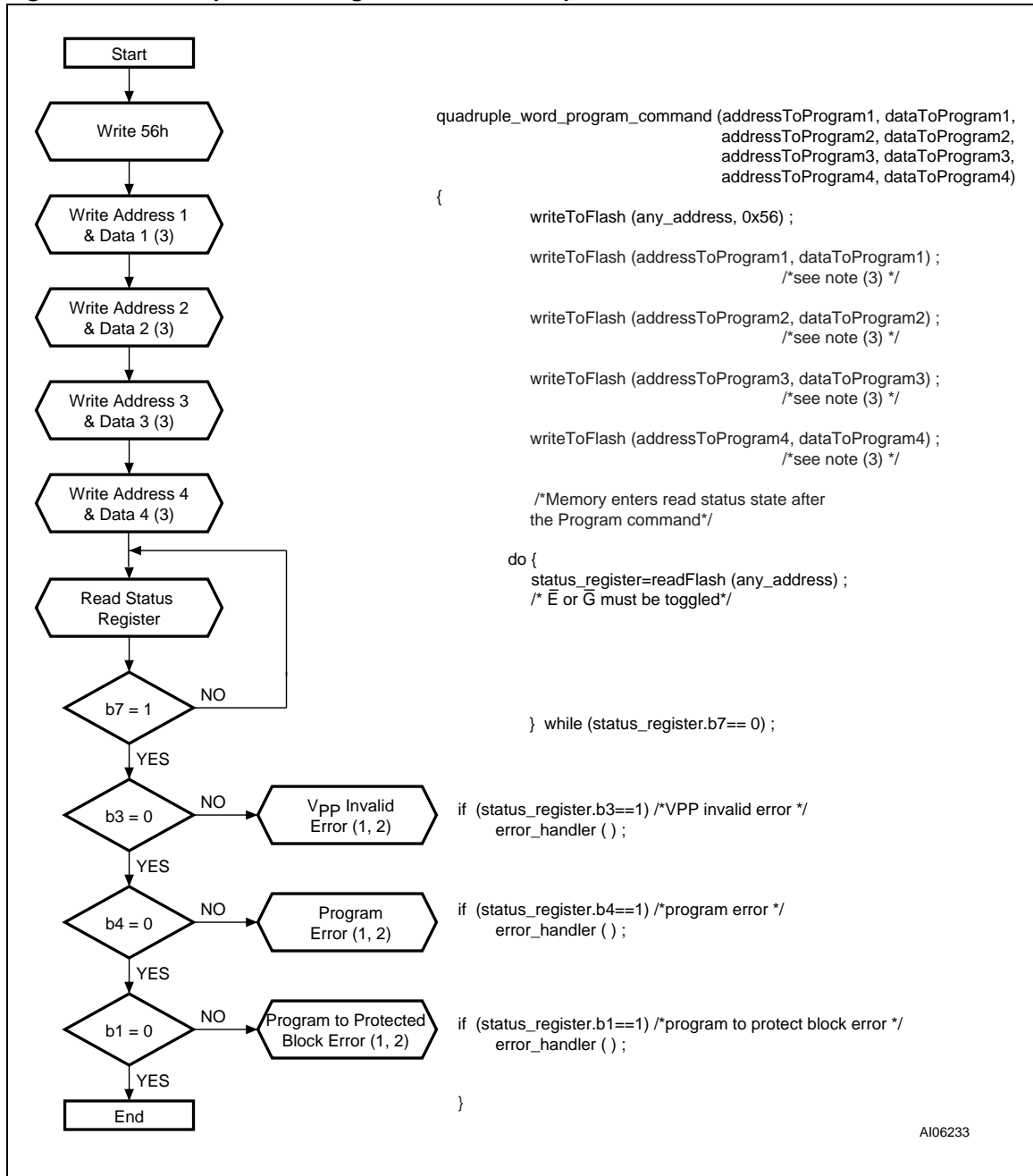

AI06233

1. Status check of b1 (Protected Block), b3 (V_{pp} Invalid) and b4 (Program Error) can be made after each program operation or after a sequence.
4. If an error is found, the Status Register must be cleared before further Program/Erase operations.
5. Address 1 to Address 4 must be consecutive addresses differing only for bits A0 and A1.

Figure 21. Program Suspend & Resume flowchart and pseudo code

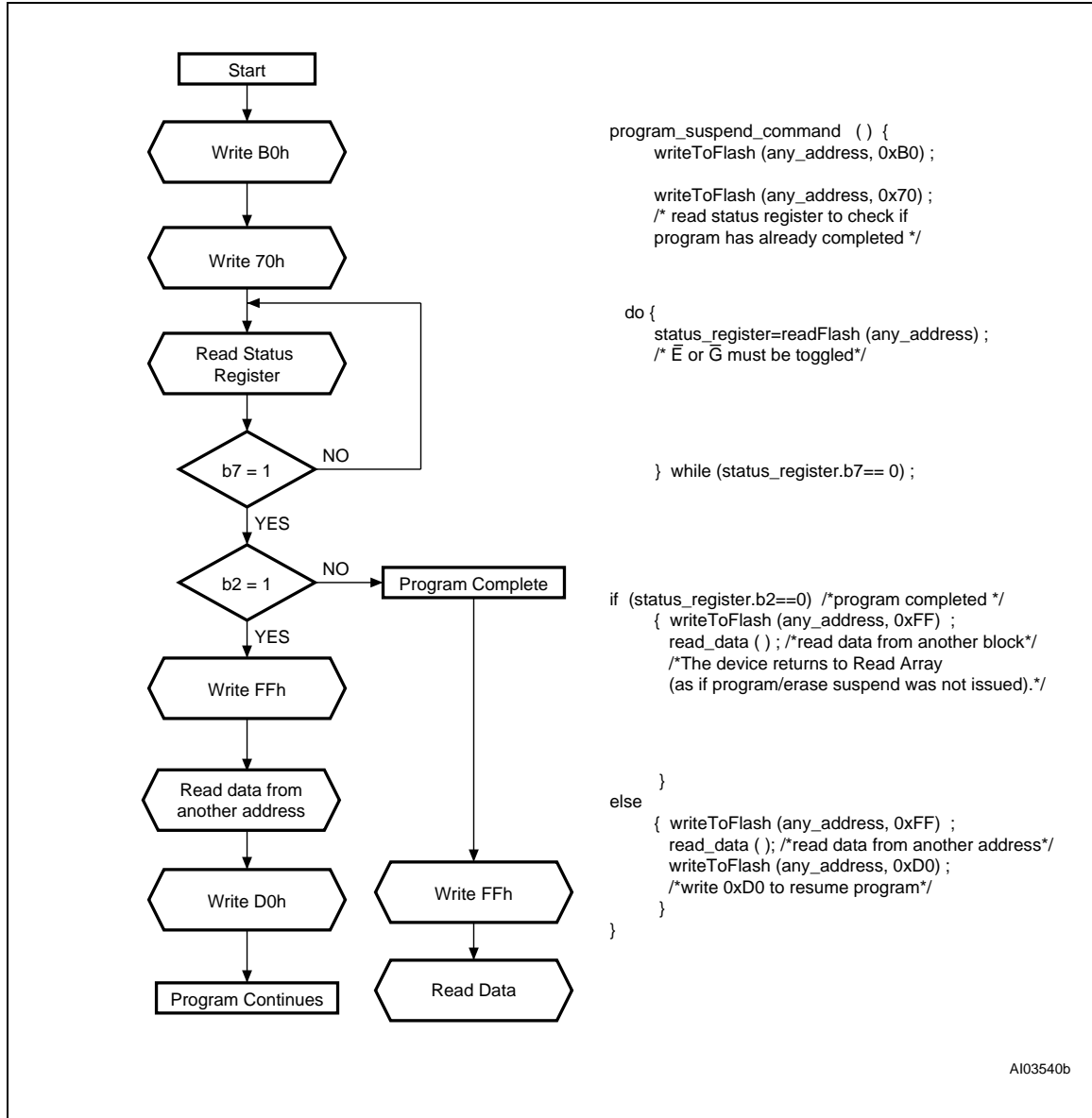
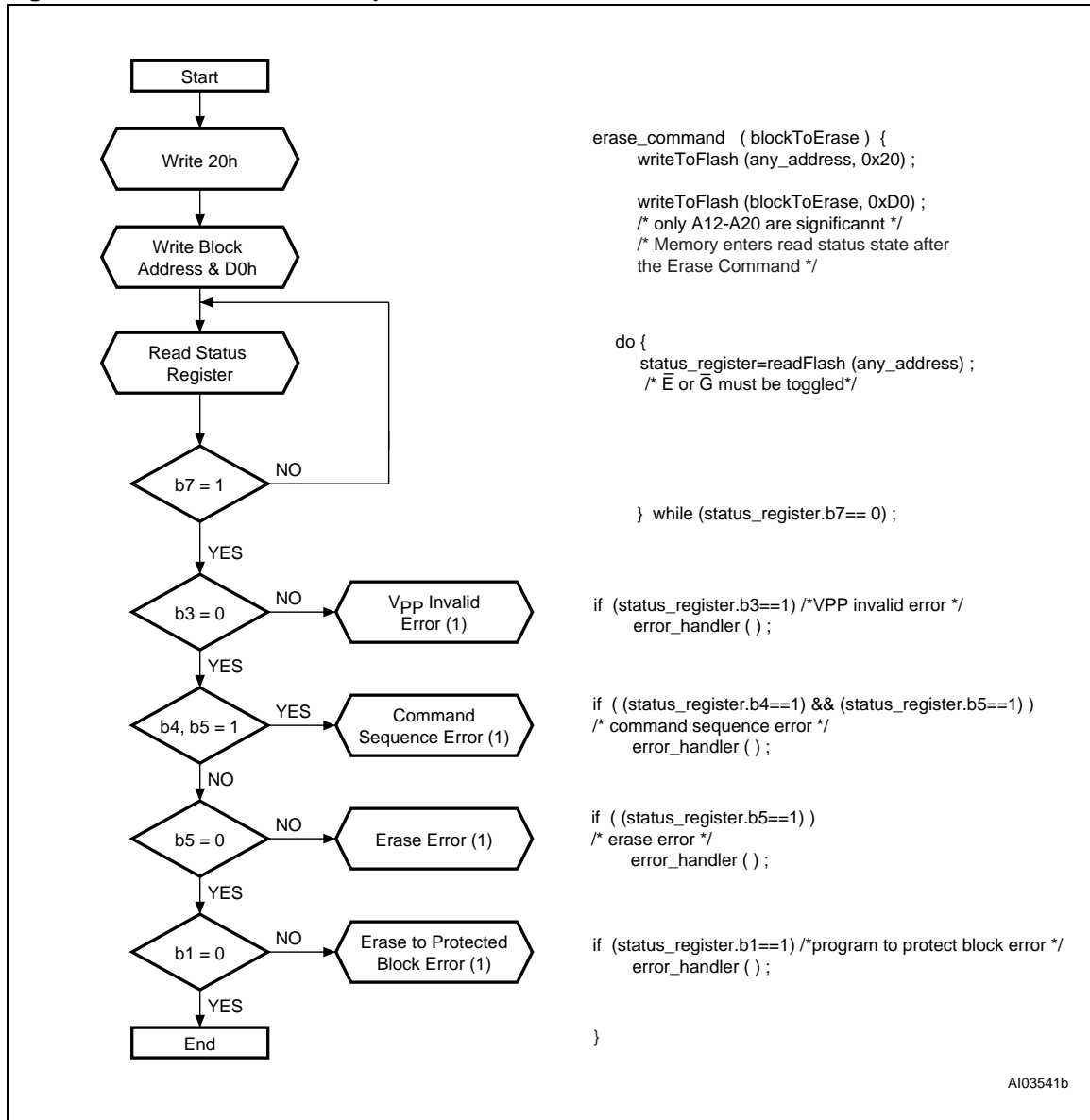
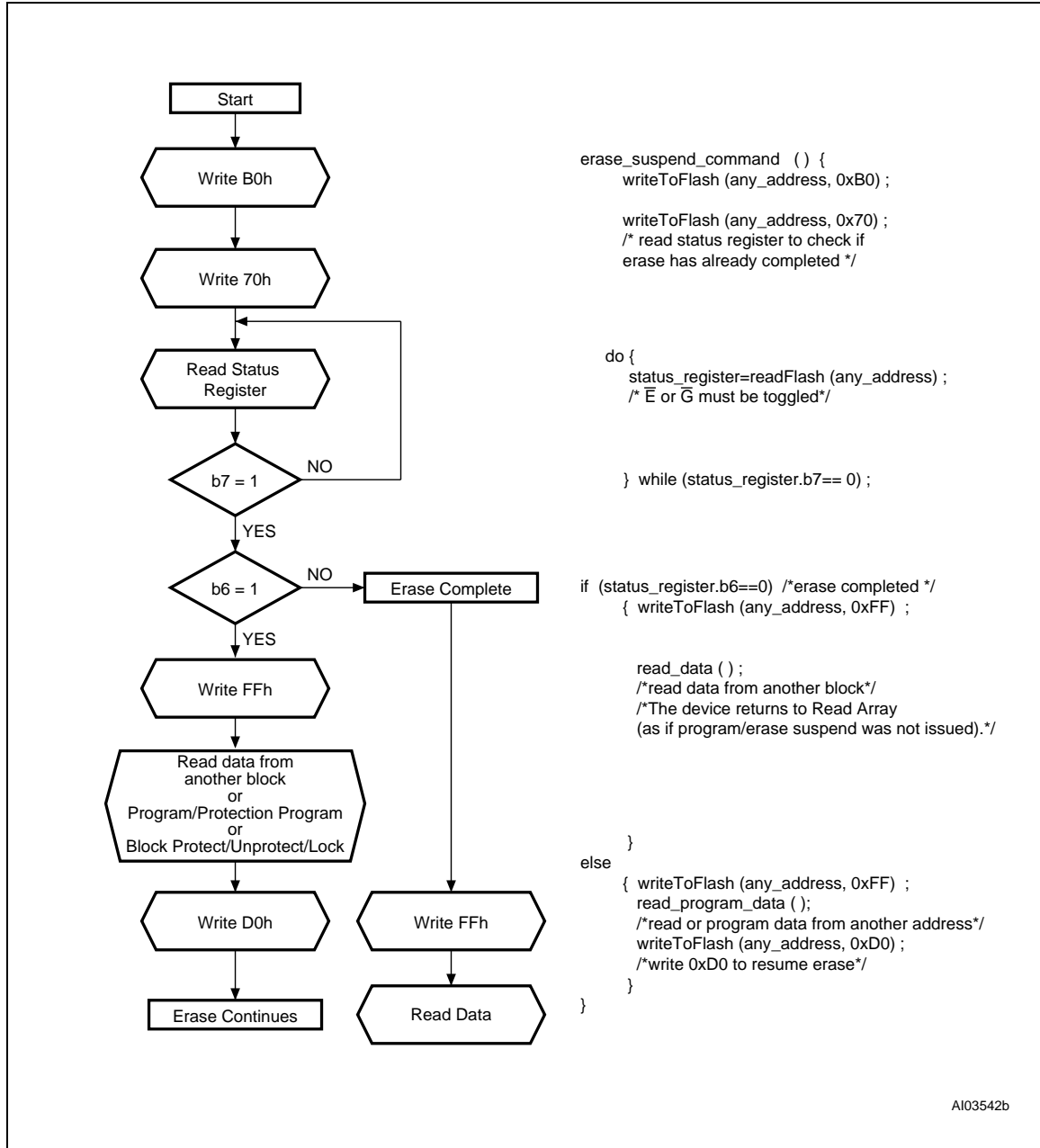

Figure 22. Erase flowchart and pseudo code



1. If an error is found, the Status Register must be cleared before further Program/Erase operations.

Figure 23. Erase Suspend & Resume flowchart and pseudo code



A103542b

Figure 24. Protection Register Program flowchart and pseudo code

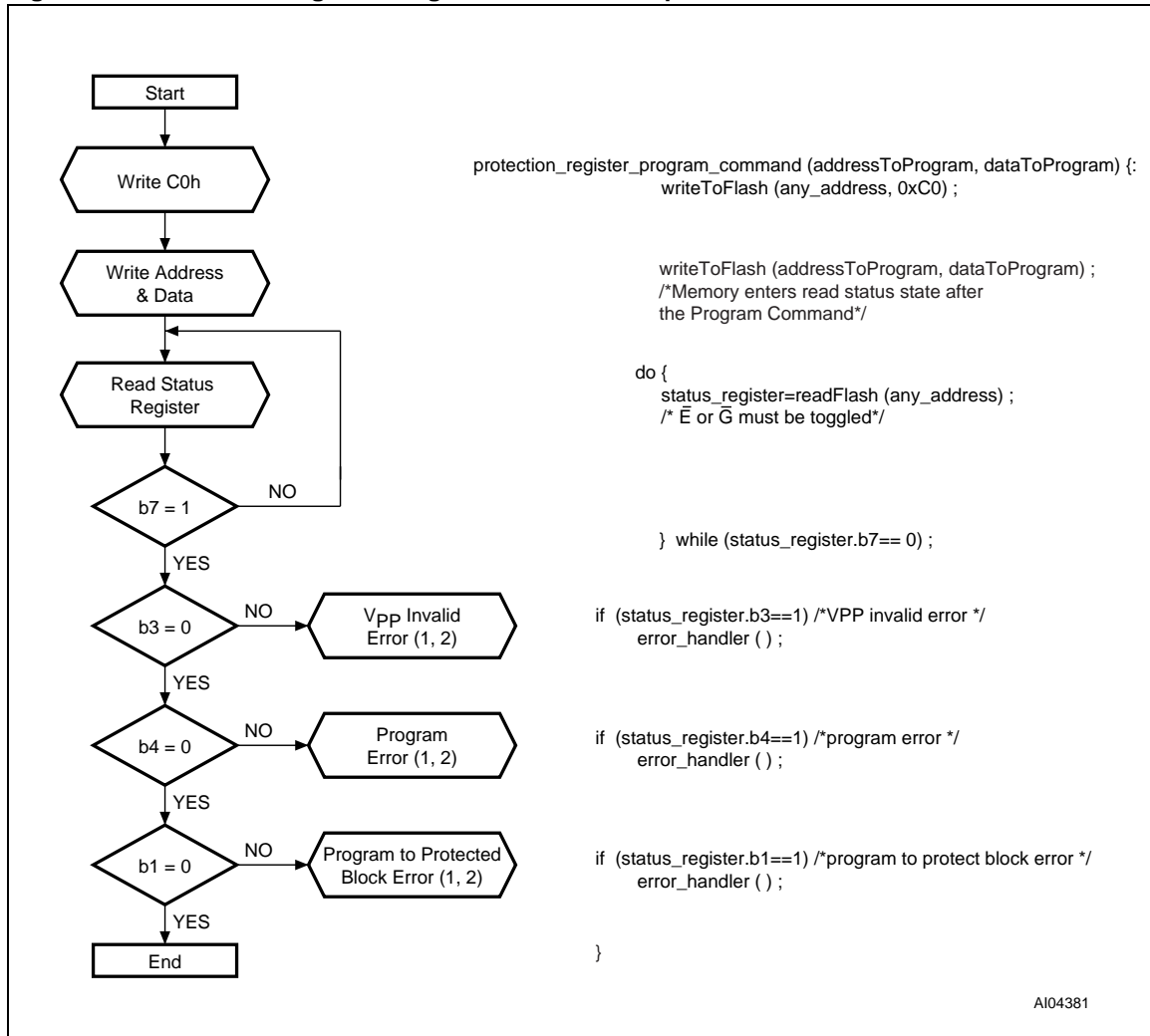

1. Status check of b1 (Protected Block), b3 (V_{PP} Invalid) and b4 (Program Error) can be made after each program operation or after a sequence.
6. If an error is found, the Status Register must be cleared before further Program/Erase Controller operations.

Appendix D Command Interface and Program/Erase Controller state

Table 34. Write State Machine Current/Next, sheet 1 of 2.⁽¹⁾

Current State	SR bit 7	Data When Read	Command Input (and Next State)								
			Read Array (FFh)	Program Setup (10/40h)	Erase Setup (20h)	Erase Confirm (D0h)	Prog/Ers Suspend (B0h)	Prog/Ers Resume (D0h)	Read Status (70h)	Clear Status (50h)	
Read Array	"1"	Array	Read Array	Prog. Setup	Ers. Setup	Read Array			Read Sts.	Read Array	
Read Status	"1"	Status	Read Array	Program Setup	Erase Setup	Read Array			Read Status	Read Array	
Read Elect.Sg.	"1"	Electronic Signature	Read Array	Program Setup	Erase Setup	Read Array			Read Status	Read Array	
Read CFI Query	"1"	CFI	Read Array	Program Setup	Erase Setup	Read Array			Read Status	Read Array	
Prot. Prog. Setup	"1"	Status	Protection Register Program								
Prot. Prog. (continue)	"0"	Status	Protection Register Program continue								
Prot. Prog. (complete)	"1"	Status	Read Array	Program Setup	Erase Setup	Read Array			Read Status	Read Array	
Prog. Setup	"1"	Status	Program								
Program (continue)	"0"	Status	Program (continue)				Prog. Sus Read Sts	Program (continue)			
Prog. Sus Status	"1"	Status	Prog. Sus Read Array	Program Suspend to Read Array		Program (continue)	Prog. Sus Read Array	Program (continue)	Prog. Sus Read Sts	Prog. Sus Read Array	
Prog. Sus Read Array	"1"	Array	Prog. Sus Read Array	Program Suspend to Read Array		Program (continue)	Prog. Sus Read Array	Program (continue)	Prog. Sus Read Sts	Prog. Sus Read Array	
Prog. Sus Read Elect.Sg.	"1"	Electronic Signature	Prog. Sus Read Array	Program Suspend to Read Array		Program (continue)	Prog. Sus Read Array	Program (continue)	Prog. Sus Read Sts	Prog. Sus Read Array	
Prog. Sus Read CFI	"1"	CFI	Prog. Sus Read Array	Program Suspend to Read Array		Program (continue)	Prog. Sus Read Array	Program (continue)	Prog. Sus Read Sts	Prog. Sus Read Array	
Program (complete)	"1"	Status	Read Array	Program Setup	Erase Setup	Read Array			Read Status	Read Array	
Erase Setup	"1"	Status	Erase Command Error			Erase (continue)	Erase CmdError	Erase (continue)	Erase Command Error		
Erase Cmd.Error	"1"	Status	Read Array	Program Setup	Erase Setup	Read Array			Read Status	Read Array	

Table 34. Write State Machine Current/Next, sheet 1 of 2.⁽¹⁾ (continued)

Current State	SR bit 7	Data When Read	Command Input (and Next State)								
			Read Array (FFh)	Program Setup (10/40h)	Erase Setup (20h)	Erase Confirm (D0h)	Prog/Ers Suspend (B0h)	Prog/Ers Resume (D0h)	Read Status (70h)	Clear Status (50h)	
Erase (continue)	"0"	Status	Erase (continue)				Erase Sus Read Sts	Erase (continue)			
Erase Sus Read Sts	"1"	Status	Erase Sus Read Array	Program Setup	Erase Sus Read Array	Erase (continue)	Erase Sus Read Array	Erase (continue)	Erase Sus Read Sts	Erase Sus Read Array	
Erase Sus Read Array	"1"	Array	Erase Sus Read Array	Program Setup	Erase Sus Read Array	Erase (continue)	Erase Sus Read Array	Erase (continue)	Erase Sus Read Sts	Erase Sus Read Array	
Erase Sus Read Elect.Sg.	"1"	Electronic Signature	Erase Sus Read Array	Program Setup	Erase Sus Read Array	Erase (continue)	Erase Sus Read Array	Erase (continue)	Erase Sus Read Sts	Erase Sus Read Array	
Erase Sus Read CFI	"1"	CFI	Erase Sus Read Array	Program Setup	Erase Sus Read Array	Erase (continue)	Erase Sus Read Array	Erase (continue)	Erase Sus Read Sts	Erase Sus Read Array	
Erase (complete)	"1"	Status	Read Array	Program Setup	Erase Setup	Read Array			Read Status	Read Array	

1. Cmd = Command, Elect.Sg. = Electronic Signature, Ers = Erase, Prog. = Program, Prot = Protection, Sus = Suspend.

Table 35. Write State Machine Current/Next, sheet 2 of 2.⁽¹⁾

Current State	Command Input (and Next State)		
	Read Elect.Sg. (90h)	Read CFI Query (98h)	Prot. Prog. Setup (C0h)
Read Array	Read Elect.Sg.	Read CFI Query	Prot. Prog. Setup
Read Status	Read Elect.Sg.	Read CFI Query	Prot. Prog. Setup
Read Elect.Sg.	Read Elect.Sg.	Read CFI Query	Prot. Prog. Setup
Read CFI Query	Read Elect.Sg.	Read CFI Query	Prot. Prog. Setup
Prot. Prog. Setup	Protection Register Program		
Prot. Prog. (continue)	Protection Register Program (continue)		
Prot. Prog. (complete)	Read Elect.Sg.	Read CFI Query	Prot. Prog. Setup
Prog. Setup	Program		
Program (continue)	Program (continue)		
Prog. Suspend Read Status	Prog. Suspend Read Elect.Sg.	Prog. Suspend Read CFI Query	Program Suspend Read Array
Prog. Suspend Read Array	Prog. Suspend Read Elect.Sg.	Prog. Suspend Read CFI Query	Program Suspend Read Array
Prog. Suspend Read Elect.Sg.	Prog. Suspend Read Elect.Sg.	Prog. Suspend Read CFI Query	Program Suspend Read Array
Prog. Suspend Read CFI	Prog. Suspend Read Elect.Sg.	Prog. Suspend Read CFI Query	Program Suspend Read Array
Program (complete)	Read Elect.Sg.	Read CFI Query	Prot. Prog. Setup
Erase Setup	Erase Command Error		
Erase Cmd.Error	Read Elect.Sg.	Read CFI Query	Prot. Prog. Setup
Erase (continue)	Erase (continue)		
Erase Suspend Read Status	Erase Suspend Read Elect.Sg.	Erase Suspend Read CFI Query	Erase Suspend Read Array
Erase Suspend Read Array	Erase Suspend Read Elect.Sg.	Erase Suspend Read CFI Query	Erase Suspend Read Array
Erase Suspend Read Elect.Sg.	Erase Suspend Read Elect.Sg.	Erase Suspend Read CFI Query	Erase Suspend Read Array
Erase Suspend Read CFI Query	Erase Suspend Read Elect.Sg.	Erase Suspend Read CFI Query	Erase Suspend Read Array
Erase (complete)	Read Elect.Sg.	Read CFI Query	Prot. Prog. Setup

1. Cmd = Command, Elect.Sg. = Electronic Signature, Prog. = Program, Prot = Protection.

12 Revision history

Table 36. Document revision history

Date	Revision	Changes
25-Oct-2005	1.0	Initial release. This datasheet is the merge of the M28WxxxFS datasheet (revision 2.0) concerning the M28W320FS and M28W640FS, and of the M28WxxxFSU datasheet (revision 1.0) concerning the M28W320FSU and M28W640FSU.
21-Sep-2006	2	Small text changes. V_{IH} and V_{IL} parameters corrected in Table 14: DC characteristics . V_{SSQ} added (see Table 2: Signal names and Section 2.11: V_{SSQ} Ground). TFBGA47 package added (see Section 10: Package mechanical). Table 21: Ordering information scheme modified and Daisy Chain ordering scheme removed.
15-Dec-2006	3	Block protection state after Reset specified in Section 2.6: Reset (RP) . Command code 01h removed from Table 4: Command codes . The Protection Register Program command is not accepted during Program/Erase Suspend (see Section 6.10: Program/Erase Suspend command). M28W640FSU added at address offset (P+12)h = 47h for data 004h in Table 32: Primary algorithm-specific extended query table . Small text changes.

Please Read Carefully:

Information in this document is provided solely in connection with ST products. STMicroelectronics NV and its subsidiaries ("ST") reserve the right to make changes, corrections, modifications or improvements, to this document, and the products and services described herein at any time, without notice.

All ST products are sold pursuant to ST's terms and conditions of sale.

Purchasers are solely responsible for the choice, selection and use of the ST products and services described herein, and ST assumes no liability whatsoever relating to the choice, selection or use of the ST products and services described herein.

No license, express or implied, by estoppel or otherwise, to any intellectual property rights is granted under this document. If any part of this document refers to any third party products or services it shall not be deemed a license grant by ST for the use of such third party products or services, or any intellectual property contained therein or considered as a warranty covering the use in any manner whatsoever of such third party products or services or any intellectual property contained therein.

UNLESS OTHERWISE SET FORTH IN ST'S TERMS AND CONDITIONS OF SALE ST DISCLAIMS ANY EXPRESS OR IMPLIED WARRANTY WITH RESPECT TO THE USE AND/OR SALE OF ST PRODUCTS INCLUDING WITHOUT LIMITATION IMPLIED WARRANTIES OF MERCHANTABILITY, FITNESS FOR A PARTICULAR PURPOSE (AND THEIR EQUIVALENTS UNDER THE LAWS OF ANY JURISDICTION), OR INFRINGEMENT OF ANY PATENT, COPYRIGHT OR OTHER INTELLECTUAL PROPERTY RIGHT.

UNLESS EXPRESSLY APPROVED IN WRITING BY AN AUTHORIZED ST REPRESENTATIVE, ST PRODUCTS ARE NOT RECOMMENDED, AUTHORIZED OR WARRANTED FOR USE IN MILITARY, AIR CRAFT, SPACE, LIFE SAVING, OR LIFE SUSTAINING APPLICATIONS, NOR IN PRODUCTS OR SYSTEMS WHERE FAILURE OR MALFUNCTION MAY RESULT IN PERSONAL INJURY, DEATH, OR SEVERE PROPERTY OR ENVIRONMENTAL DAMAGE. ST PRODUCTS WHICH ARE NOT SPECIFIED AS "AUTOMOTIVE GRADE" MAY ONLY BE USED IN AUTOMOTIVE APPLICATIONS AT USER'S OWN RISK.

Resale of ST products with provisions different from the statements and/or technical features set forth in this document shall immediately void any warranty granted by ST for the ST product or service described herein and shall not create or extend in any manner whatsoever, any liability of ST.

ST and the ST logo are trademarks or registered trademarks of ST in various countries.

Information in this document supersedes and replaces all information previously supplied.

The ST logo is a registered trademark of STMicroelectronics. All other names are the property of their respective owners.

© 2006 STMicroelectronics - All rights reserved

STMicroelectronics group of companies

Australia - Belgium - Brazil - Canada - China - Czech Republic - Finland - France - Germany - Hong Kong - India - Israel - Italy - Japan - Malaysia - Malta - Morocco - Singapore - Spain - Sweden - Switzerland - United Kingdom - United States of America

www.st.com