



3.3V CMOS 16-BIT BUS TRANSCEIVER/REGISTER

IDT74FCT163646A/C

FEATURES:

- 0.5 MICRON CMOS Technology
- Typical $t_{SK(o)}$ (Output Skew) < 250ps
- ESD > 2000V per MIL-STD-883, Method 3015; > 200V using machine model (C = 200pF, R = 0)
- $V_{CC} = 3.3V \pm 0.3V$, Normal Range, or $V_{CC} = 2.7V$ to 3.6V, Extended Range
- CMOS power levels (0.4 μ W typ. static)
- Rail-to-rail output swing for increased noise margin
- Low Ground Bounce (0.3V typ.)
- Inputs (except I/O) can be driven by 3.3V or 5V components
- Available in SSOP and TSSOP packages

DESCRIPTION:

The FCT163646 16-bit registered transceiver is built using advanced dual metal CMOS technology. These high-speed, low-power devices are organized as two independent 8-bit bus transceivers with 3-state D-type registers. The control circuitry is organized for multiplexed transmission of data between A bus and B bus either directly or from the internal storage registers. Each 8-bit transceiver/register features direction control (xDIR), over-riding Output Enable control (x \overline{OE}) and Select lines (xSAB and xSBA) to select either real-time data or stored data. Separate clock inputs are provided for A and B port registers. Data on the A or B data bus, or both, can be stored in the internal registers by the low-to-high transitions at the appropriate clock pins. Flow-through organization of signal pins simplifies layout. All inputs are designed with hysteresis for improved noise margin.

The FCT163646 has series current limiting resistors. This offers low ground bounce, minimal undershoot, and controlled output fall times-reducing the need for external series terminating resistors.

FUNCTIONAL BLOCK DIAGRAM

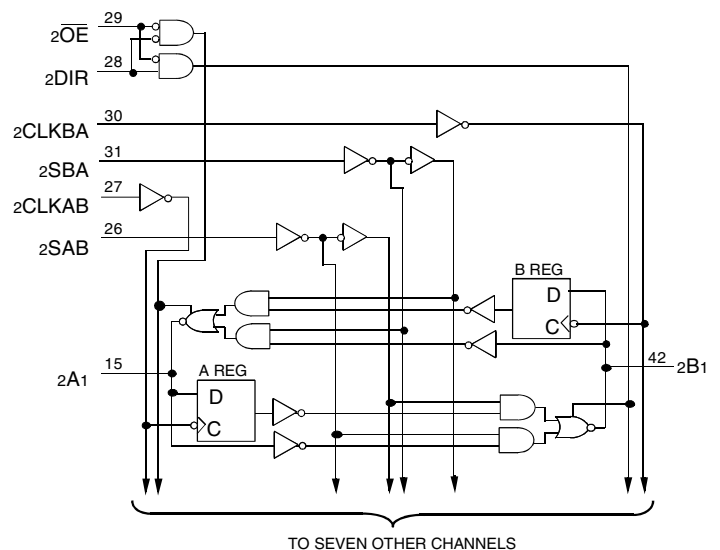
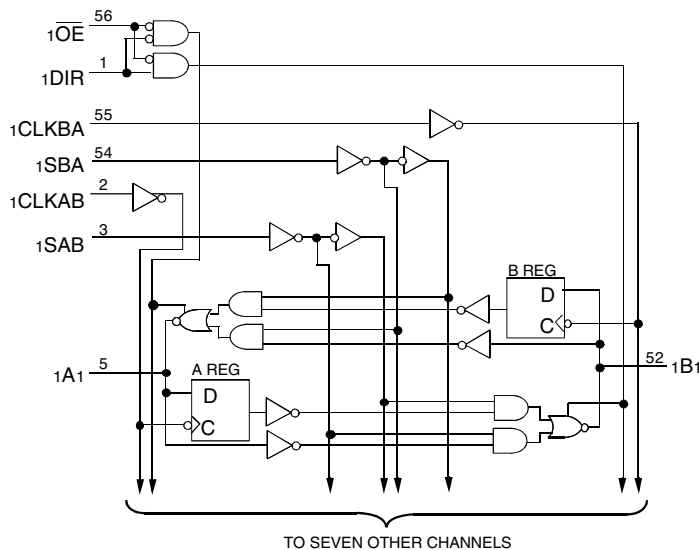

The IDT logo is a registered trademark of Integrated Device Technology, Inc.

INDUSTRIAL TEMPERATURE RANGE

APRIL 2002

PIN CONFIGURATION

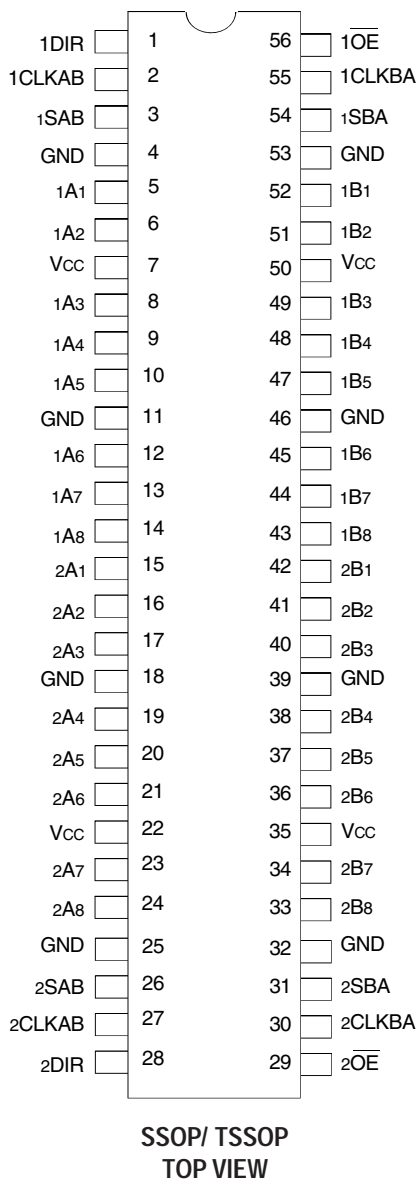

ABSOLUTE MAXIMUM RATINGS(1)

Symbol	Description	Max	Unit
VTERM ⁽²⁾	Terminal Voltage with Respect to GND	-0.5 to +4.6	V
VTERM ⁽³⁾	Terminal Voltage with Respect to GND	-0.5 to 7	V
VTERM ⁽⁴⁾	Terminal Voltage with Respect to GND	-0.5 to Vcc+0.5	V
TSTG	Storage Temperature	-65 to +150	°C
IOUT	DC Output Current	-60 to +60	mA

NOTES:

- Stresses greater than those listed under ABSOLUTE MAXIMUM RATINGS may cause permanent damage to the device. This is a stress rating only and functional operation of the device at these or any other conditions above those indicated in the operational sections of this specification is not implied. Exposure to absolute maximum rating conditions for extended periods may affect reliability.
- Vcc terminals.
- Input terminals.
- Outputs and I/O terminals.

CAPACITANCE (TA = +25°C, F = 1.0MHz)

Symbol	Parameter ⁽¹⁾	Conditions	Typ.	Max.	Unit
CIN	Input Capacitance	VIN = 0V	3.5	6	pF
COUT	Output Capacitance	VOUT = 0V	3.5	8	pF

NOTE:

- This parameter is measured at characterization but not tested.

PIN DESCRIPTION

Pin Names	Description
xAx	Data Register A Inputs, Data Register B Outputs
xBx	Data Register B Inputs, Data Register A Outputs
xCAB, xCBA	Clock Pulse Inputs
xSAB, xSBA	Output Data Source Select Inputs
xDIR, xOE	Output Enable Inputs

FUNCTION TABLE(1)

Inputs						Data I/O ⁽²⁾		Operation or Function
xOE	xDIR	xCLKAB	xCLKBA	xSAB	xSBA	xAx	xBx	
H	X	H or L	H or L	X	X	Input	Input	Isolation
H	X	↑	↑	X	X			Store A and B Data
L	L	X	X	X	L	Output	Input	Real Time B Data to A Bus
L	L	X	H or L	X	H			Stored B Data to A Bus
L	H	X	X	L	X	Input	Output	Real Time A Data to B Bus
L	H	H or L	X	H	X			Stored A Data to B Bus

NOTES:

- H = HIGH Voltage Level
L = LOW Voltage Level
X = Don't Care
↑ = LOW-to-HIGH Transition
- The data output functions may be enabled or disabled by various signals at the xOE or xDIR inputs. Data input functions are always enabled, i.e. data at the bus pins will be stored on every LOW-to-HIGH transition of the clock inputs.

DC ELECTRICAL CHARACTERISTICS OVER OPERATING RANGE

Following Conditions Apply Unless Otherwise Specified:

Industrial: $T_A = -40^{\circ}\text{C}$ to $+85^{\circ}\text{C}$, $V_{CC} = 2.7\text{V}$ to 3.6V

Symbol	Parameter	Test Conditions ⁽¹⁾	Min.	Typ. ⁽²⁾	Max.	Unit		
V _{IH}	Input HIGH Level (Input pins)	Guaranteed Logic HIGH Level	2	—	5.5	V		
	Input HIGH Level (I/O pins)		2	—	V _{CC} +0.5			
V _{IL}	Input LOW Level (Input and I/O pins)	Guaranteed Logic LOW Level	-0.5	—	0.8	V		
I _{IH}	Input HIGH Current (Input pins)	V _{CC} = Max.	V _I = 5.5V	—	—	±1		
	Input HIGH Current (I/O pins)						V _I = V _{CC}	—
I _{IL}	Input LOW Current (Input pins)		V _I = GND	—	—	±1		
	Input LOW Current (I/O pins)						V _I = GND	—
I _{OZH}	High Impedance Output Current (3-State Output pins)	V _{CC} = Max.	V _O = V _{CC}	—	—	±1		
I _{OZL}			V _O = GND	—	—	±1		
V _{IK}	Clamp Diode Voltage	V _{CC} = Min., I _{IN} = -18mA	—	-0.7	-1.2	V		
I _{ODH}	Output HIGH Current	V _{CC} = 3.3V, V _{IN} = V _{IH} or V _{IL} , V _O = 1.5V ⁽³⁾	-36	-60	-110	mA		
I _{ODL}	Output LOW Current	V _{CC} = 3.3V, V _{IN} = V _{IH} or V _{IL} , V _O = 1.5V ⁽³⁾	50	90	200	mA		
V _{OH}	Output HIGH Voltage	V _{CC} = Min.	I _{OH} = -0.1mA	V _{CC} -0.2	—	—		
		V _{IN} = V _{IH} or V _{IL}					I _{OH} = -3mA	2.4
		V _{CC} = 3V	I _{OH} = -8mA	2.4 ⁽⁵⁾	3	—		
V _{OL}	Output LOW Voltage	V _{CC} = Min.	V _{IN} = V _{IH} or V _{IL}	I _{OL} = 0.1mA	—	—	0.2	
				I _{OL} = 16mA	—	0.2		0.4
				I _{OL} = 24mA	—	0.3		
		V _{CC} = 3V	I _{OL} = 24mA	—	0.3	0.5		
I _{OS}	Short Circuit Current ⁽⁴⁾	V _{CC} = Max., V _O = GND ⁽³⁾	-60	-135	-240	mA		
V _H	Input Hysteresis	—	—	150	—	mV		
I _{CC1} I _{CC2} I _{CC3}	Quiescent Power Supply Current	V _{CC} = Max. V _{IN} = GND or V _{CC}	—	0.1	10	μA		

NOTES:

1. For conditions shown as Min. or Max., use appropriate value specified under Electrical Characteristics for the applicable device type.
2. Typical values are at V_{CC} = 3.3V, +25°C ambient.
3. Not more than one output should be shorted at one time. Duration of the test should not exceed one second.
4. This parameter is guaranteed but not tested.
5. V_{OH} = V_{CC}-0.6V at rated current.

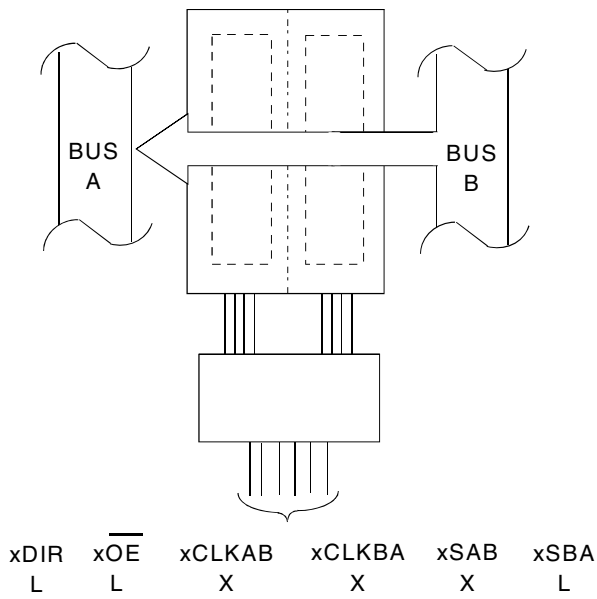

*Real-Time Transfer
Bus B to A*

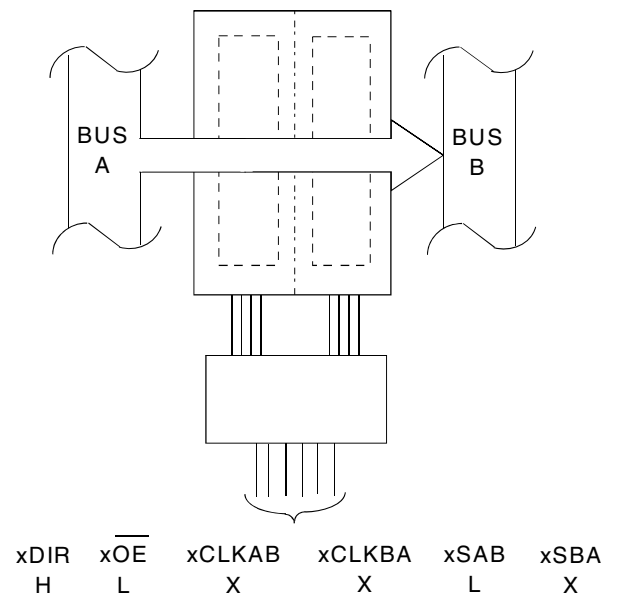

*Real-Time Transfer
Bus A to B*

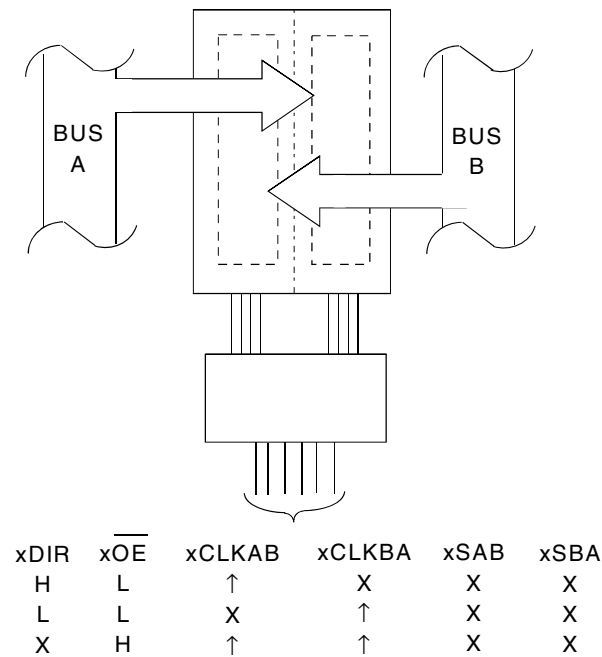

*Storage from
A and/or B*

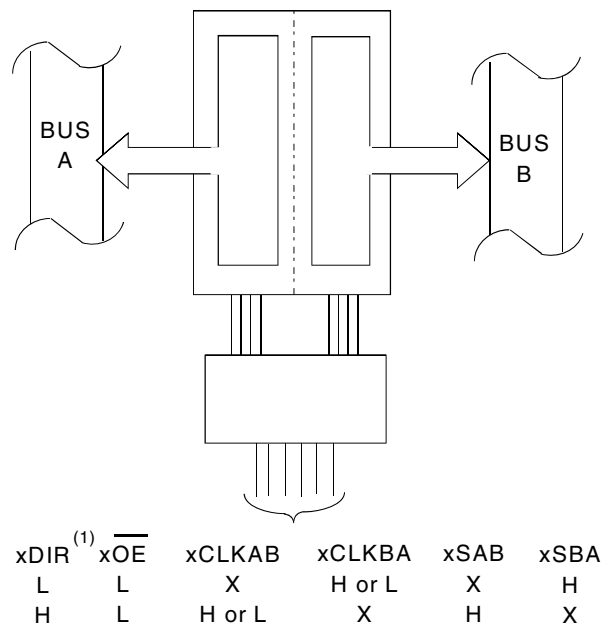

*Transfer Stored Data
to A and/or B*

NOTE:

1. Cannot transfer data to A bus and B bus simultaneously.

POWER SUPPLY CHARACTERISTICS

Symbol	Parameter	Test Conditions ⁽¹⁾		Min.	Typ. ⁽²⁾	Max.	Unit
ΔI_{CC}	Quiescent Power Supply Current TTL Inputs HIGH	$V_{CC} = \text{Max.}$ $V_{IN} = V_{CC} - 0.6V^{(3)}$		—	2	30	μA
I_{CCD}	Dynamic Power Supply Current ⁽⁴⁾	$V_{CC} = \text{Max.}$ Outputs Open $xDIR = x\overline{OE} = GND$ One Input Toggling 50% Duty Cycle	$V_{IN} = V_{CC}$ $V_{IN} = GND$	—	60	100	$\mu A / MHz$
I_C	Total Power Supply Current ⁽⁶⁾	$V_{CC} = \text{Max.}, \text{Outputs Open}$ $f_{CP} = 10MHz (xCLKBA)$ 50% Duty Cycle $xDIR = x\overline{OE} = GND$ $f_i = 5MHz$ 50% Duty Cycle One Bit Toggling	$V_{IN} = V_{CC}$ $V_{IN} = GND$	—	0.6	1	mA
			$V_{IN} = V_{CC} - 0.6V$ $V_{IN} = GND$	—	0.6	1	
		$V_{CC} = \text{Max.}, \text{Outputs Open}$ $f_{CP} = 10MHz (xCLKBA)$ 50% Duty Cycle $xDIR = x\overline{OE} = GND$ $f_i = 2.5MHz$ 50% Duty Cycle Sixteen Bits Toggling	$V_{IN} = V_{CC}$ $V_{IN} = GND$	—	3	5 ⁽⁵⁾	
			$V_{IN} = V_{CC} - 0.6V$ $V_{IN} = GND$	—	3	5.3 ⁽⁵⁾	

NOTES:

- For conditions shown as Min. or Max., use appropriate value specified under Electrical Characteristics for the applicable device type.
- Typical values are at $V_{CC} = 3.3V$, $+25^\circ C$ ambient.
- Per TTL driven input. All other inputs at V_{CC} or GND.
- This parameter is not directly testable, but is derived for use in Total Power Supply Calculations.
- Values for these conditions are examples of the I_C formula. These limits are guaranteed but not tested.
- $I_C = I_{QUIESCENT} + I_{INPUTS} + I_{DYNAMIC}$
 $I_C = I_{CC} + \Delta I_{CC} D_H N_T + I_{CCD} (f_{CP} N_{CP} / 2 + f_i N_i)$
 $I_{CC} = \text{Quiescent Current (} I_{CCL}, I_{CCH} \text{ and } I_{CCZ} \text{)}$
 $\Delta I_{CC} = \text{Power Supply Current for a TTL High Input}$
 $D_H = \text{Duty Cycle for TTL Inputs High}$
 $N_T = \text{Number of TTL Inputs at } D_H$
 $I_{CCD} = \text{Dynamic Current caused by an Input Transition Pair (HLH or LHL)}$
 $f_{CP} = \text{Clock Frequency for Register Devices (Zero for Non-Register Devices)}$
 $N_{CP} = \text{Number of Clock Inputs at } f_{CP}$
 $f_i = \text{Input Frequency}$
 $N_i = \text{Number of Inputs at } f_i$

SWITCHING CHARACTERISTICS OVER OPERATING RANGE⁽¹⁾

Symbol	Parameter	Condition ⁽²⁾	FCT163646A		FCT163646C		Unit
			Min. ⁽³⁾	Max.	Min. ⁽³⁾	Max.	
t _{PLH} t _{PHL}	Propagation Delay Bus to Bus	CL = 50pF RL = 500Ω	2	6.3	1.5	5.4	ns
t _{PZH} t _{PZL}	Output Enable Time xDIR or xOE to Bus		2	9.8	1.5	7.8	ns
t _{PHZ} t _{PLZ}	Output Disable Time xDIR or xOE to Bus		2	6.3	1.5	6.3	ns
t _{PLH} t _{PHL}	Propagation Delay Clock to Bus		2	6.3	1.5	5.7	ns
t _{PLH} t _{PHL}	Propagation Delay xSBA or xSAB to Bus		2	7.7	1.5	6.2	ns
t _{SU}	Set-up Time HIGH or LOW, Bus to Clock		2	—	2	—	ns
t _H	Hold Time HIGH or LOW, Bus to Clock		1.5	—	1.5	—	ns
t _w	Clock Pulse Width HIGH or LOW		5	—	5	—	ns
t _{SK(O)}	Output Skew ⁽⁴⁾		—	0.5	—	0.5	ns

NOTES:

1. Propagation Delays and Enable/Disable times are with V_{CC} = 3.3V ±0.3V, Normal Range. For V_{CC} = 2.7V to 3.6V, Extended Range, all Propagation Delays and Enable/Disable times should be degraded by 20%.
2. See test circuit and waveforms.
3. Minimum limits are guaranteed but not tested on Propagation Delays.
4. Skew between any two outputs, of the same package, switching in the same direction. This parameter is guaranteed by design.

TEST CIRCUITS AND WAVEFORMS

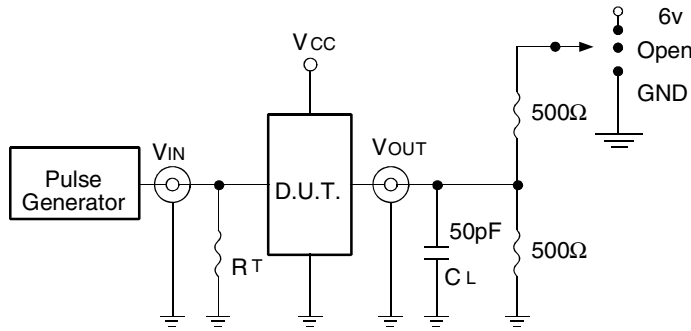

Test Circuits for All Outputs

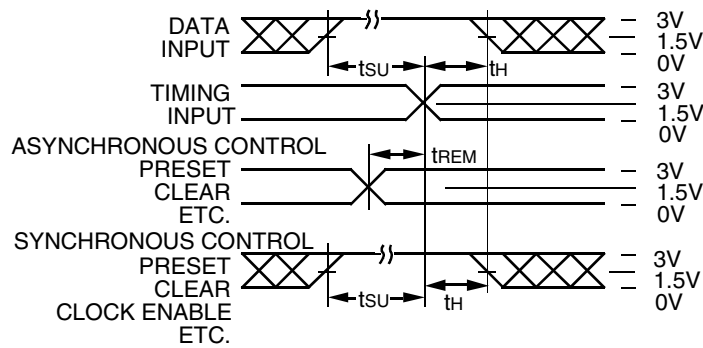

Set-up, Hold, and Release Times

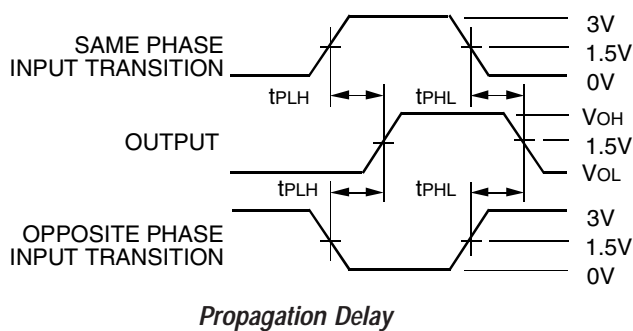

Propagation Delay

SWITCH POSITION

Test	Switch
Open Drain Disable Low Enable Low	6V
Disable High Enable High	GND
All Other Tests	Open

DEFINITIONS:

CL = Load capacitance: includes jig and probe capacitance.
RT = Termination resistance: should be equal to ZOUT of the Pulse Generator.

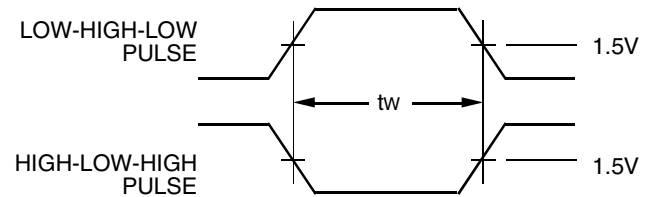

Pulse Width

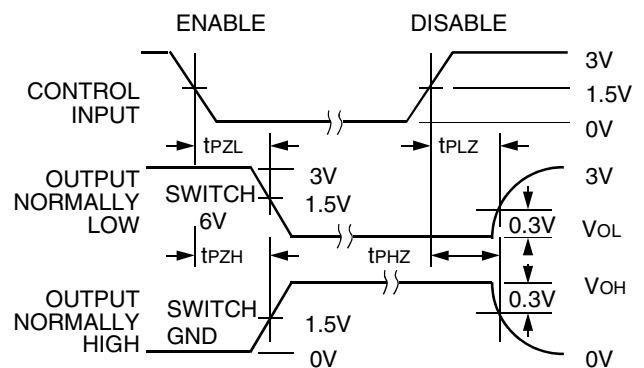

Enable and Disable Times

NOTES:

1. Diagram shown for input Control Enable-LOW and input Control Disable-HIGH.
2. Pulse Generator for All Pulses: Rate $\leq 1.0\text{MHz}$; $t_r \leq 2.5\text{ns}$; $t_f \leq 2.5\text{ns}$.
3. If VCC is below 3V, input voltage swings should be adjusted not to exceed VCC.

ORDERING INFORMATION

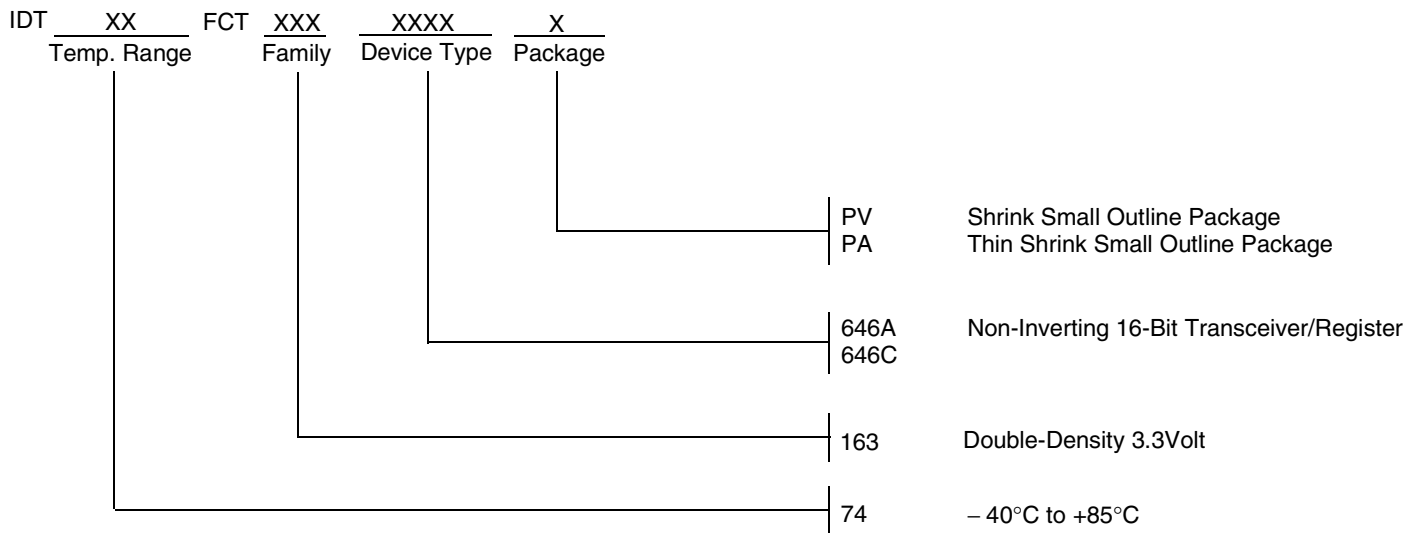

CORPORATE HEADQUARTERS
6024 Silver Creek Valley Road
San Jose, CA 95138

for SALES:
800-345-7015 or 408-284-8200
fax: 408-284-2775
www.idt.com

for Tech Support:
logichelp@idt.com