



# 3.3V CMOS 20-BIT UNIVERSAL BUS DRIVER WITH 3-STATE OUTPUTS

**IDT74ALVC162836**

## FEATURES:

- 0.5 MICRON CMOS Technology
- Typical  $t_{sk(o)}$  (Output Skew) < 250ps
- ESD > 2000V per MIL-STD-883, Method 3015; > 200V using machine model (C = 200pF, R = 0)
- $V_{cc} = 3.3V \pm 0.3V$ , Normal Range
- $V_{cc} = 2.7V$  to  $3.6V$ , Extended Range
- $V_{cc} = 2.5V \pm 0.2V$
- CMOS power levels (0.4 $\mu$  W typ. static)
- Rail-to-Rail output swing for increased noise margin
- Available in SSOP package

## DRIVE FEATURES:

- Light Balanced Output Drivers:  $\pm 12mA$
- Minimal switching noise

## DESCRIPTION:

This 20-bit universal bus driver is built using advanced dual metal CMOS technology. Data flow from A to Y is controlled by the output-enable ( $\overline{OE}$ ) input. The device operates in the transparent mode when the latch-enable ( $\overline{LE}$ ) input is low. When  $\overline{LE}$  is high, the A data is latched if the clock (CLK) input is held at a high or low logic level. If  $\overline{LE}$  is high, the A data is stored in the latch/flip-flop on the low-to-high transition of CLK. When  $\overline{OE}$  is high, the outputs are in the high-impedance state.

The ALVC162836 has series resistors in the device output structure which will significantly reduce line noise when used with light loads. This driver has been designed to drive  $\pm 12mA$  at the designated threshold levels.

## APPLICATIONS:

- SDRAM Modules
- PC Motherboards
- Workstations

## FUNCTIONAL BLOCK DIAGRAM

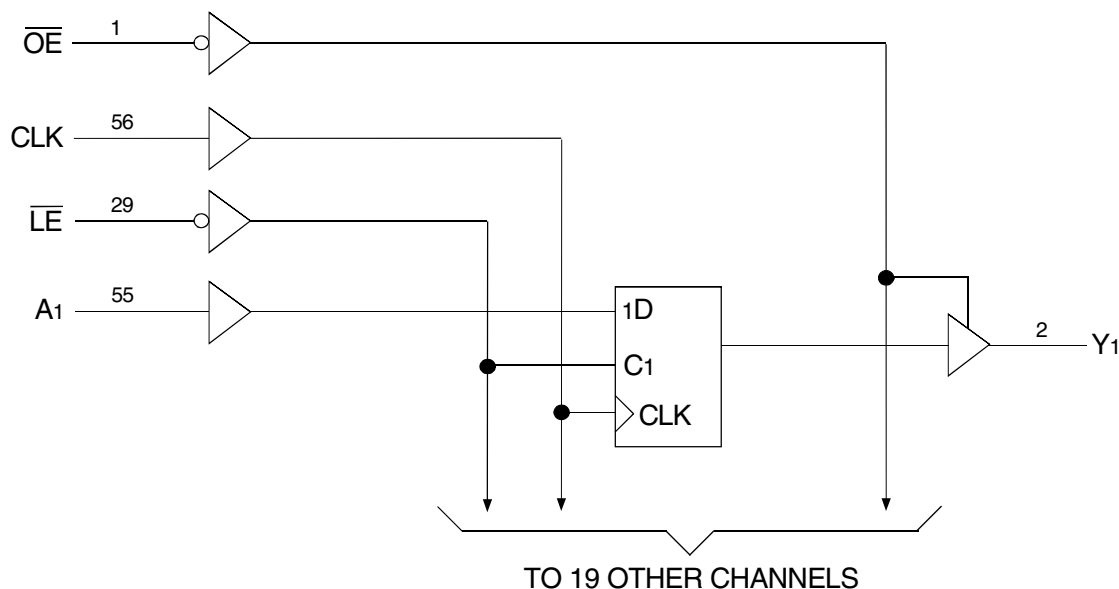

## PIN CONFIGURATION

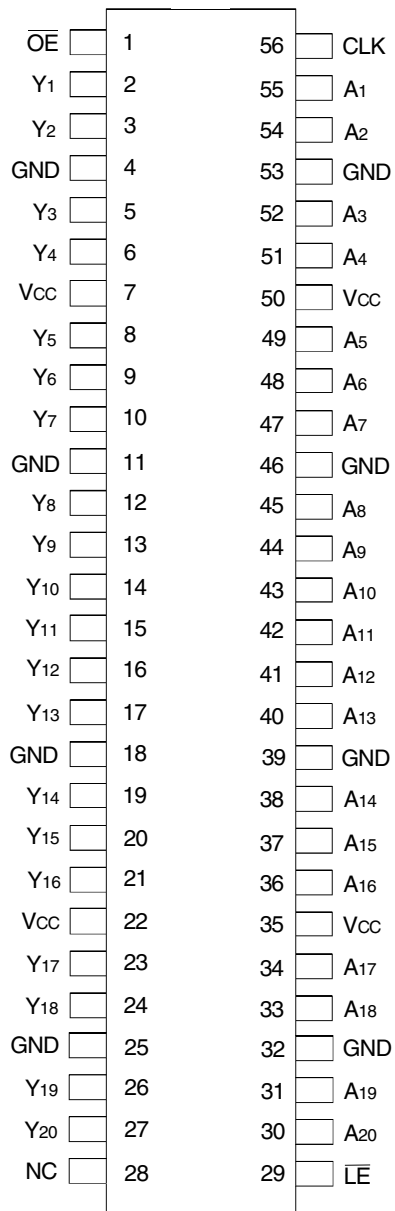

SSOP  
TOP VIEW

## PIN DESCRIPTION

Pin Names	Description
$\overline{OE}$	3-State Output Enable Inputs (Active LOW)
CLK	Register Input Clock
$\overline{LE}$	Latch Enable (Active LOW)
A <sub>x</sub>	Data Inputs
Y <sub>x</sub>	3-State Outputs
NC	No Internal Connection

## ABSOLUTE MAXIMUM RATINGS<sup>(1)</sup>

Symbol	Description	Max	Unit
V <sub>TERM</sub> <sup>(2)</sup>	Terminal Voltage with Respect to GND	-0.5 to +4.6	V
V <sub>TERM</sub> <sup>(3)</sup>	Terminal Voltage with Respect to GND	-0.5 to V <sub>CC</sub> +0.5	V
T <sub>STG</sub>	Storage Temperature	-65 to +150	°C
I <sub>OUT</sub>	DC Output Current	-50 to +50	mA
I <sub>IK</sub>	Continuous Clamp Current, V <sub>I</sub> < 0 or V <sub>I</sub> > V <sub>CC</sub>	±50	mA
I <sub>OK</sub>	Continuous Clamp Current, V <sub>O</sub> < 0	-50	mA
I <sub>CC</sub> I <sub>SS</sub>	Continuous Current through each V <sub>CC</sub> or GND	±100	mA

### NOTES:

- Stresses greater than those listed under ABSOLUTE MAXIMUM RATINGS may cause permanent damage to the device. This is a stress rating only and functional operation of the device at these or any other conditions above those indicated in the operational sections of this specification is not implied. Exposure to absolute maximum rating conditions for extended periods may affect reliability.
- V<sub>CC</sub> terminals.
- All terminals except V<sub>CC</sub>.

## CAPACITANCE (T<sub>A</sub> = +25°C, F = 1.0MHz)

Symbol	Parameter <sup>(1)</sup>	Conditions	Min	Typ.	Max.	Unit
C <sub>IN</sub>	Input Capacitance	V <sub>IN</sub> = 0V	3.3	5	6	pF
C <sub>OUT</sub>	Output Capacitance	V <sub>OUT</sub> = 0V	—	7	9	pF
C <sub>I/O</sub>	I/O Port Capacitance	V <sub>IN</sub> = 0V	—	7	9	pF

### NOTE:

- As applicable to the device type.

## FUNCTION TABLE<sup>(1)</sup>

Inputs				Outputs
$\overline{OE}$	$\overline{LE}$	CLK	A <sub>x</sub>	Y <sub>x</sub>
H	X	X	X	Z
L	L	X	L	L
L	L	X	H	H
L	H	↑	L	L
L	H	↑	H	H
L	H	H	X	Y <sub>0</sub> <sup>(2)</sup>
L	H	L	X	Y <sub>0</sub> <sup>(2)</sup>

### NOTES:

- H = HIGH Voltage Level  
L = LOW Voltage Level  
X = Don't Care  
Z = High Impedance  
↑ = LOW-to-HIGH transition
- Output level before the indicated steady-state input conditions were established.

## DC ELECTRICAL CHARACTERISTICS OVER OPERATING RANGE

Following Conditions Apply Unless Otherwise Specified:

Operating Condition:  $T_A = -40^{\circ}\text{C}$  to  $+85^{\circ}\text{C}$

Symbol	Parameter	Test Conditions		Min.	Typ. <sup>(1)</sup>	Max.	Unit
$V_{IH}$	Input HIGH Voltage Level	$V_{CC} = 2.3\text{V}$ to $2.7\text{V}$		1.7	—	—	V
		$V_{CC} = 2.7\text{V}$ to $3.6\text{V}$		2	—	—	
$V_{IL}$	Input LOW Voltage Level	$V_{CC} = 2.3\text{V}$ to $2.7\text{V}$		—	—	0.7	V
		$V_{CC} = 2.7\text{V}$ to $3.6\text{V}$		—	—	0.8	
$I_{IH}$	Input HIGH Current	$V_{CC} = 3.6\text{V}$	$V_I = V_{CC}$	—	—	$\pm 5$	$\mu\text{A}$
$I_{IL}$	Input LOW Current	$V_{CC} = 3.6\text{V}$	$V_I = \text{GND}$	—	—	$\pm 5$	$\mu\text{A}$
$I_{OZH}$	High Impedance Output Current (3-State Output pins)	$V_{CC} = 3.6\text{V}$	$V_O = V_{CC}$	—	—	$\pm 10$	$\mu\text{A}$
$I_{OZL}$			$V_O = \text{GND}$	—	—	$\pm 10$	
$V_{IK}$	Clamp Diode Voltage	$V_{CC} = 2.3\text{V}$ , $I_{IN} = -18\text{mA}$		—	-0.7	-1.2	V
$V_H$	Input Hysteresis	$V_{CC} = 3.3\text{V}$		—	100	—	mV
$I_{CCL}$ $I_{CCH}$ $I_{CCZ}$	Quiescent Power Supply Current	$V_{CC} = 3.6\text{V}$ $V_{IN} = \text{GND}$ or $V_{CC}$		—	0.1	40	$\mu\text{A}$
$\Delta I_{CC}$	Quiescent Power Supply Current Variation	One input at $V_{CC} - 0.6\text{V}$ , other inputs at $V_{CC}$ or $\text{GND}$		—	—	750	$\mu\text{A}$

**NOTE:**

1. Typical values are at  $V_{CC} = 3.3\text{V}$ ,  $+25^{\circ}\text{C}$  ambient.

## OUTPUT DRIVE CHARACTERISTICS

Symbol	Parameter	Test Conditions <sup>(1)</sup>		Min.	Max.	Unit
$V_{OH}$	Output HIGH Voltage	$V_{CC} = 2.3\text{V}$ to $3.6\text{V}$	$I_{OH} = -0.1\text{mA}$	$V_{CC} - 0.2$	—	V
			$I_{OH} = -4\text{mA}$	1.9	—	
		$V_{CC} = 2.7\text{V}$	$I_{OH} = -6\text{mA}$	1.7	—	
			$I_{OH} = -4\text{mA}$	2.2	—	
		$V_{CC} = 3\text{V}$	$I_{OH} = -8\text{mA}$	2	—	
			$I_{OH} = -6\text{mA}$	2.4	—	
$V_{OL}$	Output LOW Voltage	$V_{CC} = 2.3\text{V}$ to $3.6\text{V}$	$I_{OL} = 0.1\text{mA}$	—	0.2	V
			$I_{OL} = 4\text{mA}$	—	0.4	
		$V_{CC} = 2.7\text{V}$	$I_{OL} = 6\text{mA}$	—	0.55	
			$I_{OL} = 4\text{mA}$	—	0.4	
		$V_{CC} = 3\text{V}$	$I_{OL} = 8\text{mA}$	—	0.6	
			$I_{OL} = 6\text{mA}$	—	0.55	
		$I_{OL} = 12\text{mA}$	—	0.8		

**NOTE:**

1.  $V_{IH}$  and  $V_{IL}$  must be within the min. or max. range shown in the DC ELECTRICAL CHARACTERISTICS OVER OPERATING RANGE table for the appropriate  $V_{CC}$  range.  $T_A = -40^{\circ}\text{C}$  to  $+85^{\circ}\text{C}$ .

OPERATING CHARACTERISTICS,  $T_A = 25^\circ\text{C}$

Symbol	Parameter	Test Conditions	$V_{CC} = 2.5V \pm 0.2V$	$V_{CC} = 3.3V \pm 0.3V$	Unit
			Typical	Typical	
CPD	Power Dissipation Capacitance Outputs enabled	$C_L = 0\text{pF}$ , $f = 10\text{MHz}$	31	36	pF
CPD	Power Dissipation Capacitance Outputs disabled		7	11	

SWITCHING CHARACTERISTICS<sup>(1)</sup>

Symbol	Parameter	$V_{CC} = 2.5V \pm 0.2V$		$V_{CC} = 2.7V$		$V_{CC} = 3.3V \pm 0.3V$		Unit
		Min.	Max.	Min.	Max.	Min.	Max.	
$f_{MAX}$		150	—	150	—	150	—	MHz
$t_{PLH}$ $t_{PHL}$	Propagation Delay Ax to Yx	1	4.4	—	4.6	1.2	4	ns
$t_{PLH}$ $t_{PHL}$	Propagation Delay $\overline{LE}$ to Yx	1.1	5.8	—	6.1	1.4	5.1	ns
$t_{PLH}$ $t_{PHL}$	Propagation Delay CLK to Yx	1	5.2	—	5.5	1.9	4.5	ns
$t_{PZH}$ $t_{PZL}$	Output Enable Time $\overline{OE}$ to Yx	1.1	6.4	—	6.5	1.2	5.5	ns
$t_{PHZ}$ $t_{PLZ}$	Output Disable Time $\overline{OE}$ to Yx	1	4.7	—	5.2	1.7	5.1	ns
$t_W$	Pulse Duration, $\overline{LE}$ LOW	3.3	—	3.3	—	3.3	—	ns
$t_W$	Pulse Duration, CLK HIGH or LOW	3.3	—	3.3	—	3.3	—	ns
$t_{SU}$	Set-up Time, data before CLK $\uparrow$	1.4	—	1.7	—	1.5	—	ns
$t_{SU}$	Set-up Time, data before $\overline{LE}\uparrow$ , CLK HIGH	1.2	—	1.6	—	1.3	—	ns
$t_{SU}$	Set-up Time, data before $\overline{LE}\uparrow$ , CLK LOW	1.4	—	1.5	—	1.2	—	ns
$t_H$	Hold Time, data after CLK $\uparrow$	0.7	—	0.7	—	0.7	—	ns
$t_H$	Hold Time, data after $\overline{LE}\uparrow$ , CLK HIGH or LOW	1.1	—	1.1	—	1.1	—	ns
$t_{SK(O)}$	Output Skew <sup>(2)</sup>	—	—	—	—	—	500	ps

NOTES:

1. See TEST CIRCUITS AND WAVEFORMS.  $T_A = -40^\circ\text{C}$  to  $+85^\circ\text{C}$ .
2. Skew between any two outputs of the same package and switching in the same direction.

SWITCHING CHARACTERISTICS FROM  $0^\circ\text{C}$  TO  $65^\circ\text{C}$ ,  $C_L = 5\text{pF}$

Symbol	Parameter	$V_{CC} = 3.3V \pm 0.15V$		Unit
		Min.	Max.	
$t_{PLH}$ $t_{PHL}$	Propagation Delay CLK to xYx	1.9	4.5	ns

## TEST CIRCUITS AND WAVEFORMS

### TEST CONDITIONS

Symbol	V <sub>CC</sub> <sup>(1)</sup> = 3.3V ± 0.3V	V <sub>CC</sub> <sup>(1)</sup> = 2.7V	V <sub>CC</sub> <sup>(2)</sup> = 2.5V ± 0.2V	Unit
V <sub>LOAD</sub>	6	6	2 x V <sub>CC</sub>	V
V <sub>IH</sub>	2.7	2.7	V <sub>CC</sub>	V
V <sub>T</sub>	1.5	1.5	V <sub>CC</sub> / 2	V
V <sub>LZ</sub>	300	300	150	mV
V <sub>HZ</sub>	300	300	150	mV
C <sub>L</sub>	50	50	30	pF

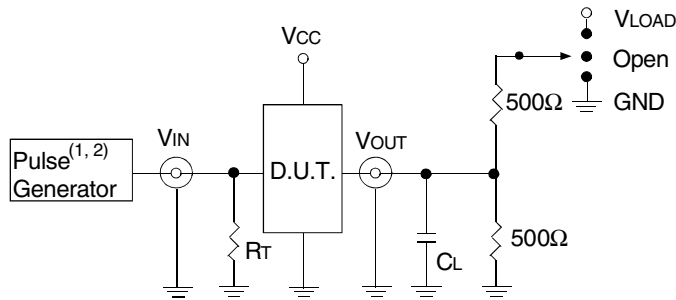

Test Circuit for All Outputs

#### DEFINITIONS:

C<sub>L</sub> = Load capacitance: includes jig and probe capacitance.  
R<sub>T</sub> = Termination resistance: should be equal to Z<sub>OUT</sub> of the Pulse Generator.

#### NOTES:

1. Pulse Generator for All Pulses: Rate ≤ 1.0MHz; t<sub>r</sub> ≤ 2.5ns; t<sub>r</sub> ≤ 2.5ns.
2. Pulse Generator for All Pulses: Rate ≤ 1.0MHz; t<sub>r</sub> ≤ 2ns; t<sub>r</sub> ≤ 2ns.

### SWITCH POSITION

Test	Switch
Open Drain Disable Low Enable Low	V <sub>LOAD</sub>
Disable High Enable High	GND
All Other Tests	Open

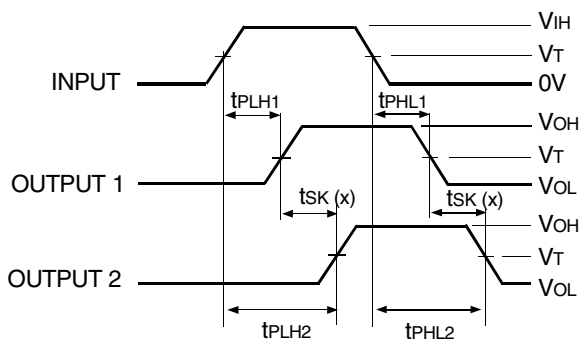

$$tsk(x) = |t_{PLH2} - t_{PLH1}| \text{ or } |t_{PHL2} - t_{PHL1}|$$

Output Skew - tsk(x)

#### NOTES:

1. For tsk(o) OUTPUT1 and OUTPUT2 are any two outputs.
2. For tsk(b) OUTPUT1 and OUTPUT2 are in the same bank.

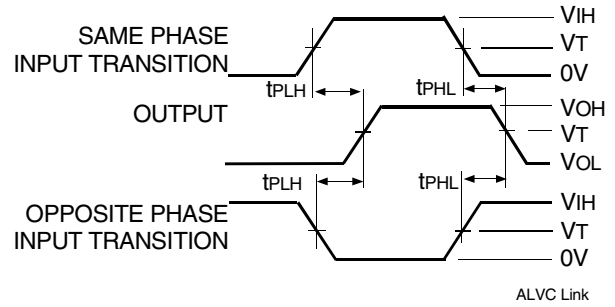

Propagation Delay

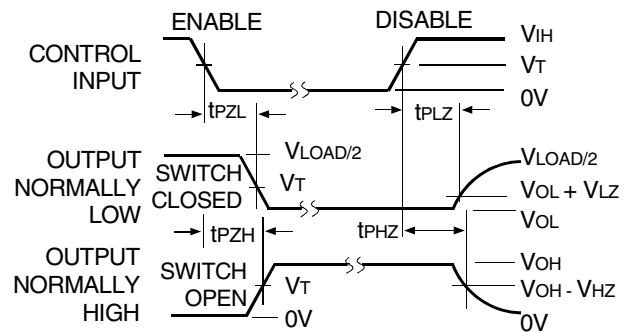

Enable and Disable Times

#### NOTE:

1. Diagram shown for input Control Enable-LOW and input Control Disable-HIGH.

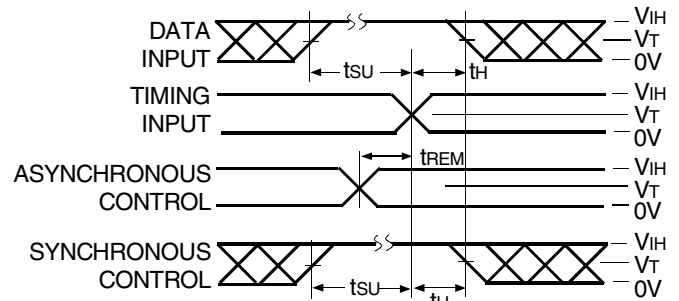

Set-up, Hold, and Release Times

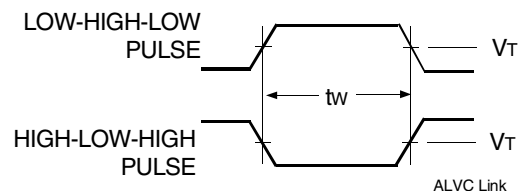

Pulse Width

## ORDERING INFORMATION

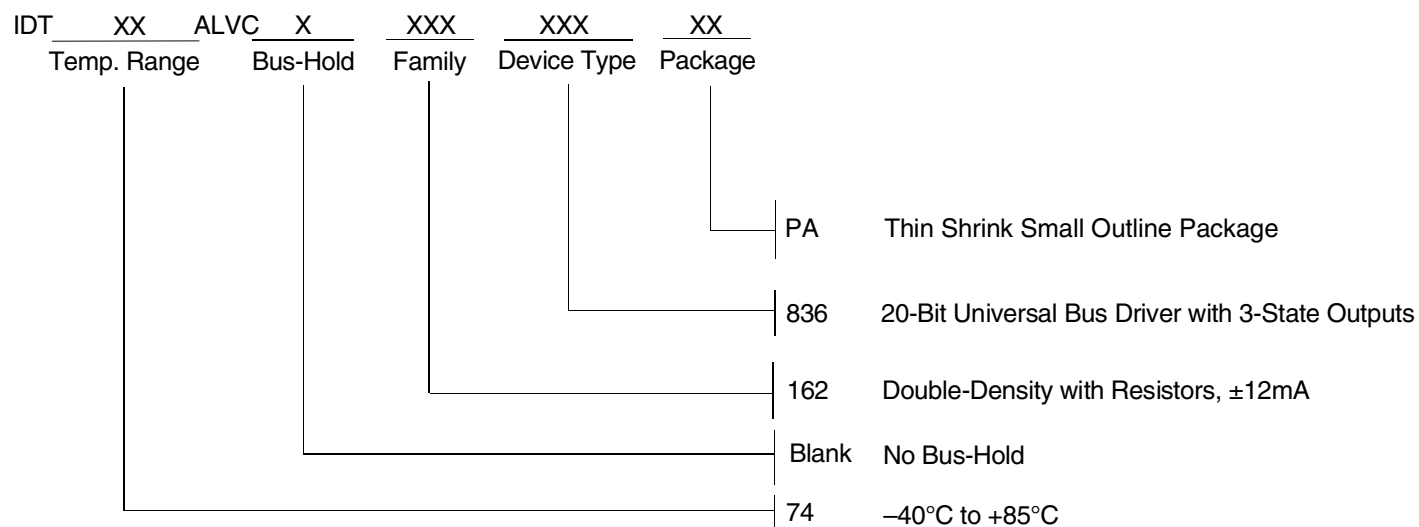

**CORPORATE HEADQUARTERS**  
 6024 Silver Creek Valley Road  
 San Jose, CA 95138

**for SALES:**  
 800-345-7015 or 408-284-8200  
 fax: 408-284-2775  
 www.idt.com

**for Tech Support:**  
 logichelp@idt.com