



THIS SPEC IS OBSOLETE

Spec No: 38-07174

Spec Title: W211B FTG for 440BX, VIA Apollo Pro-133,
and ProMedia

Sunset Owner: Rose Galindez (RGL)

Replaced by: None

FTG for 440BX, VIA Apollo Pro-133, and ProMedia

Features

- Maximized EMI Suppression using Cypress's Spread Spectrum technology
- Single-chip system frequency synthesizer for 440BX, VIA Apollo Pro-133, and ProMedia
- Supports Intel® Pentium® II and Cyrix class processors
- Two copies of CPU output
- Six copies of PCI output
- One 48-MHz output for USB
- One 24-MHz or 48-MHz output for SIO
- Two buffered reference outputs
- One IOAPIC output
- Thirteen SDRAM outputs provide support for 3 DIMMs
- Supports frequencies up to 200 MHz
- SMBus interface for programming
- Power management control inputs
- Available in 48-pin SSOP
- SDRAM Range = 66 MHz to 133 MHz

Key Specifications

CPU Cycle-to-Cycle Jitter:	250 ps
CPU to CPU Output Skew:	175 ps
PCI to PCI Output Skew:	500 ps
V _{DDQ3} :	3.3V ± 5%
V _{DDQ2} :	2.5V ± 5%
SDRAMIN to SDRAM0:12 Delay:	4.5 – 6.0 ns

Table 1. Mode Input Table

Mode	Pin 2
0	CPU_STOP#
1	REF0

Table 2. Pin Selectable Frequency

Input Address				CPU_F,	PCI_F,1:5	Spread
FS3	FS2	FS1	FS0	CPU1 (MHz)	(MHz)	Spectrum
1	1	1	1	133.3	33.3	±0.5%
1	1	1	0	75	37.5	OFF
1	1	0	1	100.2	33.3	±0.5%
1	1	0	0	66.8	33.4	±0.5%
1	0	1	1	79	39.5	OFF
1	0	1	0	110	36.7	OFF
1	0	0	1	115	38.3	OFF
1	0	0	0	120	30	OFF
0	1	1	1	133.3	33.3	-0.5%
0	1	1	0	83	27.7	OFF
0	1	0	1	100.2	33.3	-0.5%
0	1	0	0	66.8	33.4	-0.5%
0	0	1	1	122	30.5	-0.5%
0	0	1	0	129	32.3	OFF
0	0	0	1	138	34.5	OFF
0	0	0	0	95	31.7	-0.5%

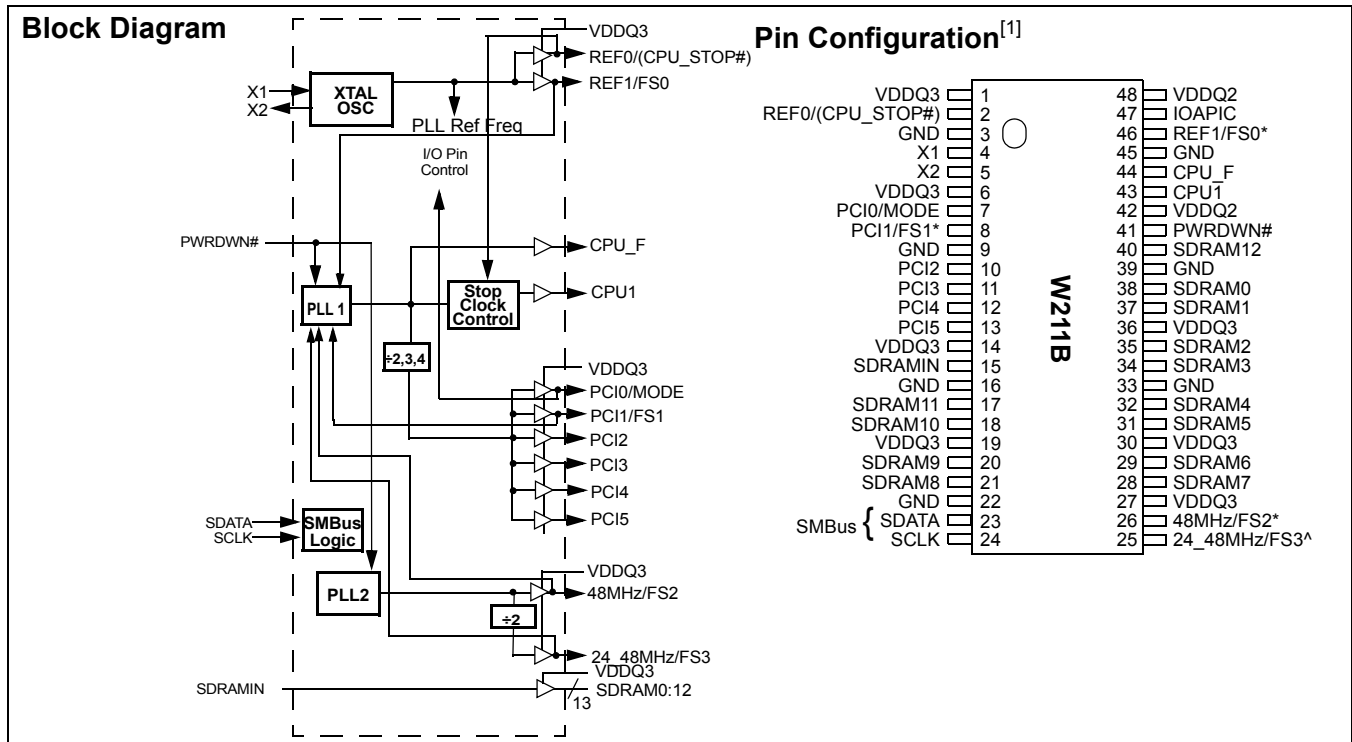

Note:

1. Internal pull-up resistors should not be relied upon for setting I/O pins HIGH. Pin function with parentheses determined by MODE pin resistor strapping. Unlike other I/O pins, input FS3 has an internal pull-down resistor.

Pin Definitions

Pin Name	Pin No.	Pin Type	Pin Description
CPU_F	44	O	Free-running CPU Clock: Output voltage swing is controlled by the voltage applied to VDDQ2. See <i>Table 2</i> and <i>Table 6</i> for detailed frequency information.
CPU1	43	O	CPU Clock Output 1: This CPU clock output is controlled by the CPU_STOP# and PWRDWN# control pin. Output voltage swing is controlled by voltage applied to VDDQ2.
PCI2:5	10, 11, 12, 13	O	PCI Clock Outputs 2 through 5: These four PCI clock outputs are controlled by the PWRDWN# control pin. Frequency is set by FS0:3 inputs or through serial input interface, see <i>Tables 2</i> and <i>6</i> for details. Output voltage swing is controlled by voltage applied to VDDQ3.
PCI1/FS1	8	I/O	Fixed PCI Clock Output/Frequency Select 1: As an output, frequency is set by FS0:3 inputs or through serial input interface. This output is controlled by the PWRDWN# input. This pin also serves as a power-on strap option to determine device operating frequency as described in <i>Table 2</i> .
PCI0/MODE	7	I/O	Fixed PCI Clock Output/Mode: As an output, frequency is set by the FS0:3 inputs or through serial input interface, see <i>Table 2</i> and <i>Table 6</i> . This output is controlled by the PWRDWN# input. This pin also serves as a power-on strap option to determine the function of pin 2. See <i>Table 1</i> for details.
PWRDWN#	41	I	PWRDWN# input: LVTTTL-compatible input that places the device in power-down mode when held LOW.
IOAPIC	47	O	IOAPIC Clock Output: Provides 14.318-MHz fixed frequency. The output voltage swing is controlled by VDDQ2. This output is disabled when PWRDWN# is set LOW.
48MHz/FS2	26	I/O	48-MHz Output/Frequency Select 2: 48 MHz is provided in normal operation. In standard PC systems, this output can be used as the reference for the Universal Serial Bus host controller. This pin also serves as a power-on strap option to determine device operating frequency as described in <i>Table 2</i> .
24_48MHz/FS3	25	I/O	24_48-MHz Output/Frequency Select 3: In standard PC systems, this output can be used as the clock input for a Super I/O chip. The output frequency is controlled by Configuration Byte 3 bit[6]. The default output frequency is 48 MHz. This pin also serves as a power-on strap option to determine device operating frequency as described in <i>Table 2</i> .
REF1/FS0	46	I/O	Reference Clock Output 1/Frequency Select 2: 3.3V 14.318-MHz output clock. This pin also serves as a power-on strap option to determine device operating frequency as described in <i>Table 2</i> . Upon power-up, FS0 input will be latched which will set clock frequencies as described in <i>Table 2</i> .
REF0/CPU_STOP#	2	I/O	Reference Clock Output 0 or CPU_STOP# Input Pin: Function is determined by the MODE pin. When CPU_STOP# input is asserted LOW, it will disable CPU1 output and drive it to logic 0. When this pin is configured as an output, this pin becomes a 3.3V 14.318-MHz output clock.
SDRAMIN	15	I	Buffered Input Pin: The signal provided to this input pin is buffered to 13 outputs (SDRAM0:12).
SDRAM0:12	38, 37, 35, 34, 32, 31, 29, 28, 21, 20, 18, 17, 40	O	Buffered Outputs: These thirteen dedicated outputs provide copies of the signal provided at the SDRAMIN input. The swing is set by VDDQ3, and they are deactivated when PWRDWN# input is set LOW.
SCLK	24	I	Clock pin for SMBus circuitry.
SDATA	23	I/O	Data pin for SMBus circuitry.
X1	4	I	Crystal Connection or External Reference Frequency Input: This pin has dual functions. It can be used as an external 14.318-MHz crystal connection or as an external reference frequency input.
X2	5	I	Crystal Connection: An input connection for an external 14.318-MHz crystal. If using an external reference, this pin must be left unconnected.
VDDQ3	1, 6, 14, 19, 27, 30, 36	P	Power Connection: Power supply for core logic, PLL circuitry, SDRAM outputs, PCI outputs, reference outputs, 48-MHz output, and 24_48-MHz output, connect to 3.3V supply.
VDDQ2	42, 48	P	Power Connection: Power supply for IOAPIC, CPU_F, and CPU1 output buffers, connect to 2.5V or 3.3V.
GND	3, 9, 16, 22, 33, 39, 45	G	Ground Connections: Connect all ground pins to the common system ground plane.

Overview

The W211B was developed as a single-chip device to meet the clocking needs of both Intel 440BX and VIA Apollo Pro-133 core logic chip sets. In addition to the typical outputs provided by a standard FTG, the W211B adds a thirteenth output buffer, supporting SDRAM DIMM modules in conjunction with the chipset.

Cypress's proprietary spread spectrum frequency synthesis technique is a feature of the CPU and PCI outputs. When enabled, this feature reduces the peak EMI measurements of not only the output signals and their harmonics, but also of any other clock signals that are properly synchronized to them.

Functional Description

I/O Pin Operation

Pins 7, 8, 25, 26, and 46 are dual-purpose I/O pins. Upon power-up these pins act as logic inputs, allowing the determination of assigned device functions. A short time after power-up, the logic state of each pin is latched and the pins become clock outputs. This feature reduces device pin count by combining clock outputs with input select pins.

An external 10-k Ω "strapping" resistor is connected between the I/O pin and ground or V_{DD}. Connection to ground sets a latch to "0," connection to V_{DD} sets a latch to "1." *Figure 1* and *Figure 2* show two suggested methods for strapping resistor connections.

Upon W211B power-up, the first 2 ms of operation is used for input logic selection. During this period, the five I/O pins (7, 8, 25, 26, 46) are three-stated, allowing the output strapping resistor on the I/O pins to pull the pins and their associated capacitive clock load to either a logic HIGH or LOW state. At the end of the 2-ms period, the established logic "0" or "1" condition of the I/O pin is latched. Next the output buffer is enabled, converting the I/O pins into operating clock outputs. The 2-ms timer starts when V_{DD} reaches 2.0V. The input bits can only be reset by turning V_{DD} off and then back on again.

It should be noted that the strapping resistors have no significant effect on clock output signal integrity. The drive impedance of clock outputs is <40 Ω (nominal), which is minimally affected by the 10-k Ω strap to ground or V_{DD}. As with the series termination resistor, the output strapping resistor should be placed as close to the I/O pin as possible in order to keep the interconnecting trace short. The trace from the resistor to ground or V_{DD} should be kept less than two inches in length to prevent system noise coupling during input logic sampling.

When the clock outputs are enabled following the 2-ms input period, the specified output frequency is delivered on the pin, assuming that V_{DD} has stabilized. If V_{DD} has not yet reached full value, output frequency initially may be below target but will increase to target once V_{DD} voltage has stabilized. In either case, a short output clock cycle may be produced from the CPU clock outputs when the outputs are enabled.

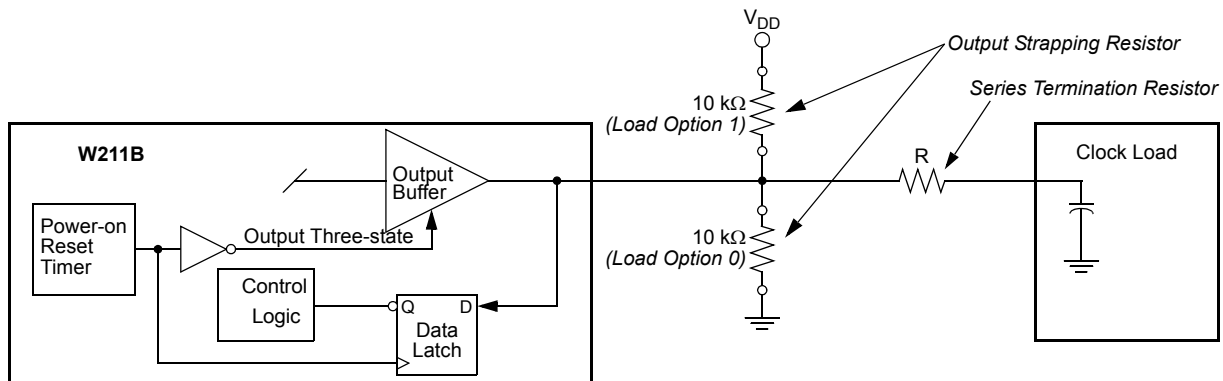

Figure 1. Input Logic Selection Through Resistor Load Option

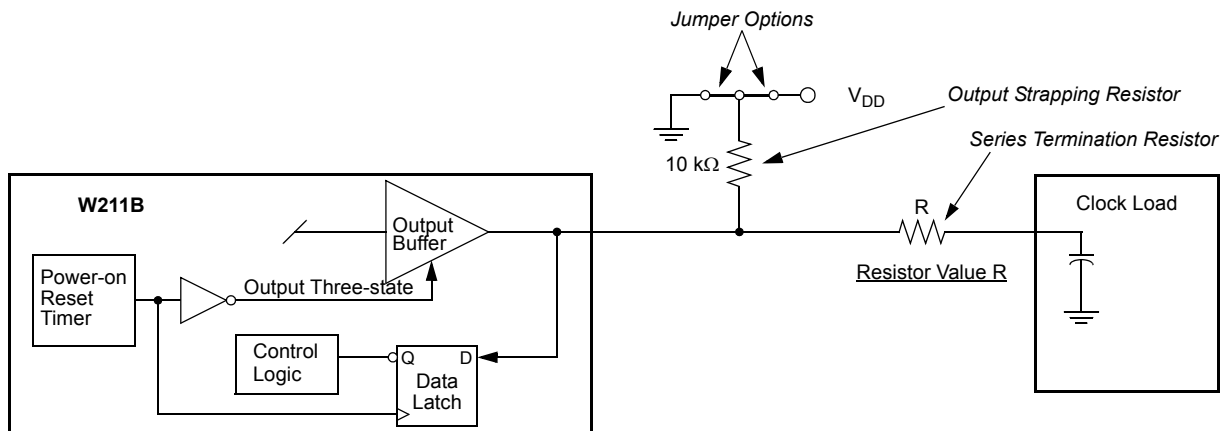

Figure 2. Input Logic Selection Through Jumper Option

Spread Spectrum Frequency Timing Generator

The device generates a clock that is frequency modulated in order to increase the bandwidth that it occupies. By increasing the bandwidth of the fundamental and its harmonics, the amplitudes of the radiated electromagnetic emissions are reduced. This effect is depicted in *Figure 3*.

As shown in *Figure 3*, a harmonic of a modulated clock has a much lower amplitude than that of an unmodulated signal. The reduction in amplitude is dependent on the harmonic number and the frequency deviation or spread. The equation for the reduction is

$$dB = 6.5 + 9 \cdot \log_{10}(P) + 9 \cdot \log_{10}(F)$$

Where P is the percentage of deviation and F is the frequency in MHz where the reduction is measured.

The output clock is modulated with a waveform depicted in *Figure 4*. This waveform, as discussed in "Spread Spectrum Clock Generation for the Reduction of Radiated Emissions" by Bush, Fessler, and Hardin produces the maximum reduction in the amplitude of radiated electromagnetic emissions. The deviation selected for this chip is specified in *Table 6*. *Figure 4* details the Cypress spreading pattern. Cypress does offer options with more spread and greater EMI reduction. Contact your local Sales representative for details on these devices.

Spread Spectrum clocking is activated or deactivated by selecting the appropriate values for bits 1–0 in data byte 0 of the SMBus data stream. Refer to *Table 6* for more details.

Serial Data Interface

The W211B features a two-pin, serial data interface that can be used to configure internal register settings that control particular device functions. Upon power-up, the W211B initializes with default register settings, therefore the use of this serial data interface is optional. The serial interface is write-only (to the clock chip) and is the dedicated function of device pins SDATA and SCLOCK. In motherboard applications, SDATA and SCLOCK are typically driven by two logic outputs of the chipset. Clock device register changes are normally made upon system initialization, if any are required. The interface can also be used during system operation for power management functions. *Table 3* summarizes the control functions of the serial data interface.

Operation

Data is written to the W211B in eleven bytes of eight bits each. Bytes are written in the order shown in *Table 4*.

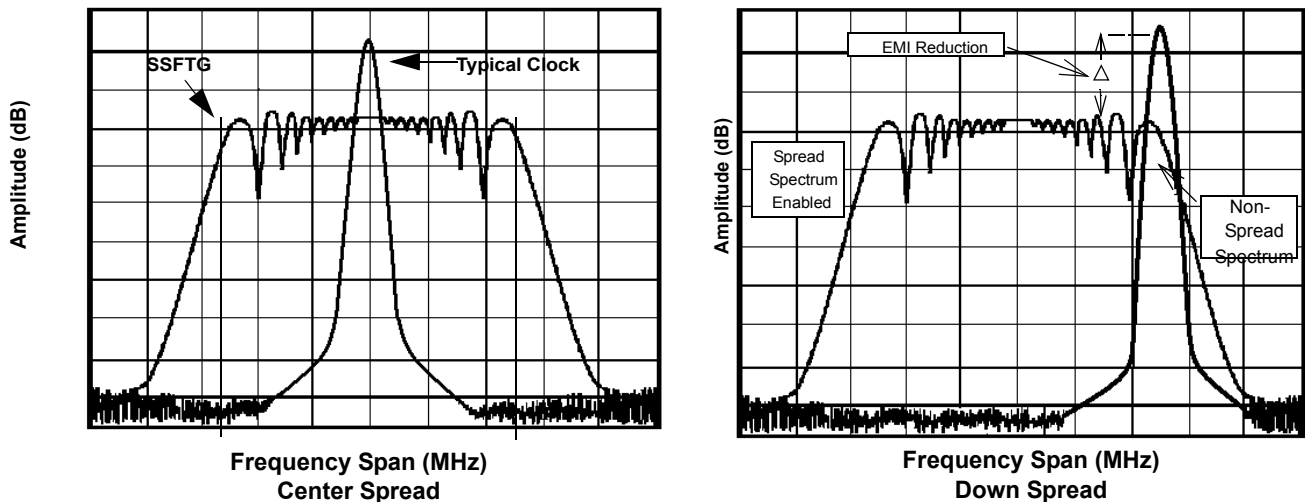

Figure 3. Clock Harmonic With and Without SSCG Modulation Frequency Domain Representation

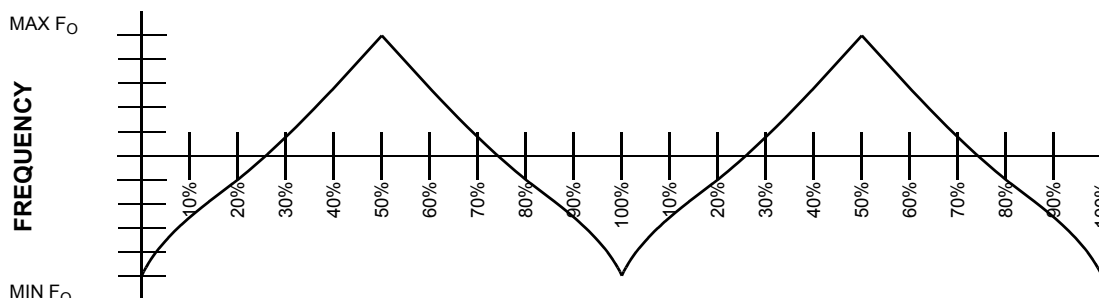

Figure 4. Typical Modulation Profile

Table 3. Serial Data Interface Control Functions Summary

Control Function	Description	Common Application
Clock Output Disable	Any individual clock output(s) can be disabled. Disabled outputs are actively held LOW.	Unused outputs are disabled to reduce EMI and system power. Examples are clock outputs to unused PCI slots.
CPU Clock Frequency Selection	Provides CPU/PCI frequency selections through software. Frequency is changed in a smooth and controlled fashion.	For alternate microprocessors and power management options. Smooth frequency transition allows CPU frequency change under normal system operation.
Spread Spectrum Enabling	Enables or disables spread spectrum clocking.	For EMI reduction.
Output Three-state	Puts clock output into a high impedance state.	Production PCB testing.
(Reserved)	Reserved function for future device revision or production device testing.	No user application. Register bit must be written as 0.

Table 4. Byte Writing Sequence

Byte Sequence	Byte Name	Bit Sequence	Byte Description
1	Slave Address	11010010	Commands the W211B to accept the bits in Data Bytes 0–6 for internal register configuration. Since other devices may exist on the same common serial data bus, it is necessary to have a specific slave address for each potential receiver. The slave receiver address for the W211B is 11010010. Register setting will not be made if the Slave Address is not correct (or is for an alternate slave receiver).
2	Command Code	Don't Care	Unused by the W211B, therefore bit values are ignored (“don't care”). This byte must be included in the data write sequence to maintain proper byte allocation. The Command Code Byte is part of the standard serial communication protocol and may be used when writing to another addressed slave receiver on the serial data bus.
3	Byte Count	Don't Care	Unused by the W211B, therefore bit values are ignored (“don't care”). This byte must be included in the data write sequence to maintain proper byte allocation. The Byte Count Byte is part of the standard serial communication protocol and may be used when writing to another addressed slave receiver on the serial data bus.
4	Data Byte 0	Refer to <i>Table 5</i>	The data bits in Data Bytes 0–7 set internal W211B registers that control device operation. The data bits are only accepted when the Address Byte bit sequence is 11010010, as noted above. For description of bit control functions, refer to <i>Table 5</i> , Data Byte Serial Configuration Map.
5	Data Byte 1		
6	Data Byte 2		
7	Data Byte 3		
8	Data Byte 4		
9	Data Byte 5		
10	Data Byte 6		
11	Data Byte 7		

Writing Data Bytes

Each bit in Data Bytes 0–7 controls a particular device function except for the “reserved” bits which must be written as a logic 0. Bits are written MSB (most significant bit) first, which is bit

7. *Table 5* gives the bit formats for registers located in Data Bytes 0–7.

Table 6 details additional frequency selections that are available through the serial data interface.

Table 5. Data Bytes 0–7 Serial Configuration Map

Bit(s)	Affected Pin		Control Function	Bit Control		Default
	Pin No.	Pin Name		0	1	
Data Byte 0						
7	—	—	(Reserved)	—	—	0
6	—	—	SEL_2	See <i>Table 6</i>		0
5	—	—	SEL_1	See <i>Table 6</i>		0

Table 5. Data Bytes 0–7 Serial Configuration Map (continued)

Bit(s)	Affected Pin		Control Function	Bit Control		Default
	Pin No.	Pin Name		0	1	
4	—	—	SEL_0	See Table 6		0
3	—	—	Hardware/Software Frequency Select	Hardware	Software	0
2	—	—	SEL_4	See Table 6		1
1	—	—	SEL_3	See Table 6		0
0	—	—		Normal	Three-stated	0
Data Byte 1						
7	—	—	(Reserved)	—	—	0
6	—	—	(Reserved)	—	—	0
5	—	—	(Reserved)	—	—	0
4	—	—	(Reserved)	—	—	0
3	40	SDRAM_12	Clock Output Disable	Low	Active	1
2	—	—	(Reserved)	—	—	0
1	43	CPU1	Clock Output Disable	Low	Active	1
0	44	CPU_F	Clock Output Disable	Low	Active	1
Data Byte 2						
7	—	—	(Reserved)	—	—	0
6	7	PCI0	Clock Output Disable	Low	Active	1
5	—	—	(Reserved)	—	—	0
4	13	PCI5	Clock Output Disable	Low	Active	1
3	12	PCI4	Clock Output Disable	Low	Active	1
2	11	PCI3	Clock Output Disable	Low	Active	1
1	10	PCI2	Clock Output Disable	Low	Active	1
0	8	PCI1	Clock Output Disable	Low	Active	1
Data Byte 3						
7	—	—	(Reserved)	—	—	0
6	—	SEL_48MHz	SEL 48MHz as the output frequency for 24_48MHz	24 MHz	48 MHz	0
5	26	48MHz	Clock Output Disable	Low	Active	1
4	25	24_48MHz	Clock Output Disable	Low	Active	1
3	—	—	(Reserved)	—	—	0
2	21, 20, 18, 17	SDRAM8:11	Clock Output Disable	Low	Active	1
1	32, 31, 29, 28	SDRAM4:7	Clock Output Disable	Low	Active	1
0	38, 37, 35, 34	SDRAM0:3	Clock Output Disable	Low	Active	1
Data Byte 4						
7	—	—	(Reserved)	—	—	0
6	—	—	(Reserved)	—	—	0
5	—	—	(Reserved)	—	—	0
4	—	—	(Reserved)	—	—	0
3	—	—	(Reserved)	—	—	0
2	—	—	(Reserved)	—	—	0
1	—	—	(Reserved)	—	—	0

Table 5. Data Bytes 0–7 Serial Configuration Map (continued)

Bit(s)	Affected Pin		Control Function	Bit Control		Default
	Pin No.	Pin Name		0	1	
0	—	—	(Reserved)	—	—	0
Data Byte 5						
7	—	—	(Reserved)	—	—	0
6	—	—	(Reserved)	—	—	0
5	—	—	(Reserved)	—	—	0
4	47	IOAPIC	Clock Output Disable	Low	Active	1
3	—	—	(Reserved)	—	—	0
2	—	—	(Reserved)	—	—	0
1	46	REF1	Clock Output Disable	Low	Active	1
0	2	REF0	Clock Output Disable	Low	Active	1
Data Byte 6						
7	—	—	(Reserved)	—	—	0
6	—	—	(Reserved)	—	—	0
5	—	—	(Reserved)	—	—	0
4	—	—	(Reserved)	—	—	0
3	—	—	(Reserved)	—	—	0
2	—	—	(Reserved)	—	—	0
1	—	—	(Reserved)	—	—	0
0	—	—	(Reserved)	—	—	0
Data Byte 7						
7	—	—	(Reserved)	—	—	0
6	—	—	(Reserved)	—	—	0
5	—	—	(Reserved)	—	—	0
4	—	—	(Reserved)	—	—	0
3	—	—	(Reserved)	—	—	0
2	—	—	(Reserved)	—	—	0
1	—	—	(Reserved)	—	—	0
0	—	—	(Reserved)	—	—	0

Table 6. Additional Frequency Selections through Serial Data Interface Data Bytes

Input Conditions					Output Frequency		
Data Byte 0, Bit 3 = 1					CPU	PCI	Spread Spectrum
Bit 2 SEL_4	Bit 1 SEL_3	Bit 6 SEL_2	Bit 5 SEL_1	Bit 4 SEL_0			
1	1	1	1	1	133.3	33.3	±0.5%
1	1	1	1	0	75	37.5	OFF
1	1	1	0	1	100.2	33.3	±0.5%
1	1	1	0	0	66.8	33.4	±0.5%
1	1	0	1	1	79	39.5	OFF
1	1	0	1	0	110	36.7	OFF
1	1	0	0	1	115	38.3	OFF
1	1	0	0	0	120	30	OFF
1	0	1	1	1	133.3	33.3	–0.5%
1	0	1	1	0	83	27.7	OFF

Table 6. Additional Frequency Selections through Serial Data Interface Data Bytes (continued)

Input Conditions					Output Frequency		
Data Byte 0, Bit 3 = 1					CPU	PCI	Spread Spectrum
Bit 2 SEL_4	Bit 1 SEL_3	Bit 6 SEL_2	Bit 5 SEL_1	Bit 4 SEL_0			
1	0	1	0	1	100.2	33.3	-0.5%
1	0	1	0	0	66.8	33.4	-0.5%
1	0	0	1	1	122	30.5	-0.5%
1	0	0	1	0	129	32.3	OFF
1	0	0	0	1	138	34.5	OFF
1	0	0	0	0	95	31.7	-0.5%
0	1	1	1	1	85	28.3	OFF
0	1	1	1	0	87.5	29.2	OFF
0	1	1	0	1	90	30	OFF
0	1	1	0	0	92.5	30.8	OFF
0	1	0	1	1	95	31.7	OFF
0	1	0	1	0	147	36.8	OFF
0	1	0	0	1	152	30.4	OFF
0	1	0	0	0	154	30.8	OFF
0	0	1	1	1	157	31.4	OFF
0	0	1	1	0	159	31.8	OFF
0	0	1	0	1	162	32.4	OFF
0	0	1	0	0	166	33.2	OFF
0	0	0	1	1	171	34.2	OFF
0	0	0	1	0	180	36	OFF
0	0	0	0	1	190	38	OFF
0	0	0	0	0	200	40	OFF

Absolute Maximum Ratings^[2]

Stresses greater than those listed in this table may cause permanent damage to the device. These represent a stress

rating only. Operation of the device at these or any other conditions above those specified in the operating sections of this specification is not implied. Maximum conditions for extended periods may affect reliability.

Parameter	Description	Rating	Unit
V_{DD}, V_{IN}	Voltage on any pin with respect to GND	-0.5 to +7.0	V
T_{STG}	Storage Temperature	-65 to +150	°C
T_B	Ambient Temperature under Bias	-55 to +125	°C
T_A	Operating Temperature	0 to +70	°C
ESD_{PROT}	Input ESD Protection	2 (min.)	kV

DC Electrical Characteristics: $T_A = 0^{\circ}\text{C}$ to $+70^{\circ}\text{C}$, $V_{DDQ3} = 3.3\text{V} \pm 5\%$, $V_{DDQ2} = 2.5\text{V} \pm 5\%$

Parameter	Description	Test Condition	Min.	Typ.	Max.	Unit
Supply Current						
I_{DD}	3.3V Supply Current	CPU_F; CPU1=100 MHz Outputs Loaded ^[3]		260		mA
I_{DD}	2.5V Supply Current	CPU_F; CPU1=100 MHz Outputs Loaded ^[3]		25		mA
Logic Inputs						
V_{IL}	Input Low Voltage		GND - 0.3		0.8	V
V_{IH}	Input High Voltage		2.0		$V_{DD} + 0.3$	V
I_{IL}	Input Low Current ^[4]				-25	μA
I_{IH}	Input High Current ^[4]				10	μA
Clock Outputs						
V_{OL}	Output Low Voltage	$I_{OL} = 1\text{ mA}$			50	mV
V_{OH}	Output High Voltage	$I_{OH} = -1\text{ mA}$	3.1			V
V_{OH}	Output High Voltage	CPU_F:1, IOAPIC $I_{OH} = -1\text{ mA}$	2.2			V
I_{OL}	Output Low Current	CPU_F, CPU1 $V_{OL} = 1.25\text{V}$	27	57	97	mA
		PCI0:5 $V_{OL} = 1.5\text{V}$	20.5	53	139	mA
		IOAPIC $V_{OL} = 1.25\text{V}$	40	85	140	mA
		REF0:1 $V_{OL} = 1.5\text{V}$	25	37	76	mA
		48-MHz $V_{OL} = 1.5\text{V}$	25	37	76	mA
		SDRAM0:15,_F $V_{OH} = 1.5\text{V}$	75	95	120	mA
		24-MHz $V_{OL} = 1.5\text{V}$	25	37	76	mA
I_{OH}	Output High Current	CPU_F, CPU1 $V_{OH} = 1.25\text{V}$	25	55	97	mA
		PCI0:5 $V_{OH} = 1.5\text{V}$	31	55	139	mA
		IOAPIC $V_{OH} = 1.25\text{V}$	40	87	155	mA
		REF0:1 $V_{OH} = 1.5\text{V}$	27	44	94	mA
		48-MHz $V_{OH} = 1.5\text{V}$	27	44	94	mA
		24-MHz $V_{OH} = 1.5\text{V}$	25	37	76	mA
		SDRAM0:15,_F $V_{OL} = 1.5\text{V}$	95	110	130	mA

Notes:

- Multiple Supplies: The voltage on any input or I/O pin cannot exceed the power pin during power-up. Power supply sequencing is NOT required.
- All clock outputs loaded with 6 60Ω transmission lines with 22-pF capacitors.
- W211B logic inputs (except FS3) have internal pull-up devices (pull-ups not full CMOS level). Logic input FS3 has an internal pull-down device.

DC Electrical Characteristics: $T_A = 0^\circ\text{C to } +70^\circ\text{C}$, $V_{DDQ3} = 3.3\text{V}\pm 5\%$, $V_{DDQ2} = 2.5\text{V}\pm 5\%$ (continued)

Parameter	Description	Test Condition	Min.	Typ.	Max.	Unit
Crystal Oscillator						
V_{TH}	X1 Input Threshold Voltage ^[5]	$V_{DDQ3} = 3.3\text{V}$		1.65		V
C_{LOAD}	Load Capacitance, Imposed on External Crystal ^[6]			14		pF
$C_{IN,X1}$	X1 Input Capacitance ^[7]	Pin X2 unconnected		28		pF
Pin Capacitance/Inductance						
C_{IN}	Input Pin Capacitance	Except X1 and X2			5	pF
C_{OUT}	Output Pin Capacitance				6	pF
L_{IN}	Input Pin Inductance				7	nH

AC Electrical Characteristics
 $T_A = 0^\circ\text{C to } +70^\circ\text{C}$, $V_{DDQ3} = 3.3\text{V}\pm 5\%$, $V_{DDQ2} = 2.5\text{V}\pm 5\%$ $f_{XTL} = 14.31818\text{ MHz}$

AC clock parameters are tested and guaranteed over stated operating conditions using the stated lump capacitive load at the clock output; Spread Spectrum is disabled.

CPU Clock Outputs, CPU_F, 1 (Lump Capacitance Test Load = 20 pF)

Parameter	Description	Test Condition/ Comments	CPU = 66.6 MHz			CPU = 100 MHz			CPU = 133 MHz			Unit
			Min.	Typ.	Max.	Min.	Typ.	Max.	Min.	Typ.	Max.	
t_P	Period	Measured on rising edge at 1.25V.	15		15.5	10		10.5	7.5		8.0	ns
t_H	High Time	Duration of clock cycle above 2.0V.	5.2			3.0			1.87			ns
t_L	Low Time	Duration of clock cycle below 0.4V.	5.0			2.8			1.67			ns
t_R	Output Rise Edge Rate	Measured from 0.4V to 2.0V.	1		4	1		4	1		4	V/ns
t_F	Output Fall Edge Rate	Measured from 2.0V to 0.4V.	1		4	1		4	1		4	V/ns
t_D	Duty Cycle	Measured on rising and falling edge at 1.25V.	45		55	45		55	45		55	%
t_{JC}	Jitter, Cycle-to-Cycle	Measured on rising edge at 1.25V. Maximum difference of cycle time between two adjacent cycles.			200			200			250	ps
t_{SK}	Output Skew	Measured on rising edge at 1.25V.			175			175			175	ps
f_{ST}	Frequency Stabilization from Power-up (cold start)	Assumes full supply voltage reached within 1 ms from power-up. Short cycles exist prior to frequency stabilization.			3			3			3	ms
Z_o	AC Output Impedance	Average value during switching transition. Used for determining series termination value.		20			20			20		Ω

Notes:

- X1 input threshold voltage (typical) is $V_{DDQ3}/2$.
- The W211B contains an internal crystal load capacitor between pin X1 and ground and another between pin X2 and ground. Total load placed on crystal is 14 pF; this includes typical stray capacitance of short PCB traces to crystal.
- X1 input capacitance is applicable when driving X1 with an external clock source (X2 is left unconnected).

PCI Clock Outputs, PCI0:5 (Lump Capacitance Test Load = 30 pF)

Parameter	Description	Test Condition/Comments	Min.	Typ.	Max.	Unit
t _P	Period	Measured on rising edge at 1.5V	30			ns
t _H	High Time	Duration of clock cycle above 2.4V	12			ns
t _L	Low Time	Duration of clock cycle below 0.4V	12			ns
t _R	Output Rise Edge Rate	Measured from 0.4V to 2.4V	1		4	V/ns
t _F	Output Fall Edge Rate	Measured from 2.4V to 0.4V	1		4	V/ns
t _D	Duty Cycle	Measured on rising and falling edge at 1.5V	45		55	%
t _{JC}	Jitter, Cycle-to-Cycle	Measured on rising edge at 1.5V. Maximum difference of cycle time between two adjacent cycles.			250	ps
t _{SK}	Output Skew	Measured on rising edge at 1.5V			500	ps
t _O	CPU to PCI Clock Skew	Covers all CPU/PCI outputs. Measured on rising edge at 1.5V. CPU leads PCI output.	1.5		4	ns
f _{ST}	Frequency Stabilization from Power-up (cold start)	Assumes full supply voltage reached within 1 ms from power-up. Short cycles exist prior to frequency stabilization.			3	ms
Z _O	AC Output Impedance	Average value during switching transition. Used for determining series termination value.		30		Ω

IOAPIC Clock Output (Lump Capacitance Test Load = 20 pF)

Parameter	Description	Test Condition/Comments	Min.	Typ.	Max.	Unit
f	Frequency, Actual	Frequency generated by crystal oscillator	14.318			MHz
t _R	Output Rise Edge Rate	Measured from 0.4V to 2.0V	1		4	V/ns
t _F	Output Fall Edge Rate	Measured from 2.0V to 0.4V	1		4	V/ns
t _D	Duty Cycle	Measured on rising and falling edge at 1.25V	45		55	%
f _{ST}	Frequency Stabilization from Power-up (cold start)	Assumes full supply voltage reached within 1 ms from power-up. Short cycles exist prior to frequency stabilization.			1.5	ms
Z _O	AC Output Impedance	Average value during switching transition. Used for determining series termination value.		15		Ω

REF0:1 Clock Outputs (Lump Capacitance Test Load = 20 pF)

Parameter	Description	Test Condition/Comments	Min.	Typ.	Max.	Unit
f	Frequency, Actual	Frequency generated by crystal oscillator	14.318			MHz
t _R	Output Rise Edge Rate	Measured from 0.4V to 2.4V	0.5		2	V/ns
t _F	Output Fall Edge Rate	Measured from 2.4V to 0.4V	0.5		2	V/ns
t _D	Duty Cycle	Measured on rising and falling edge at 1.5V	45		55	%
f _{ST}	Frequency Stabilization from Power-up (cold start)	Assumes full supply voltage reached within 1 ms from power-up. Short cycles exist prior to frequency stabilization.			3	ms
Z _O	AC Output Impedance	Average value during switching transition. Used for determining series termination value.		40		Ω

SDRAM 0:12 Clock Outputs (Lump Capacitance Test Load = 22 pF)

Parameter	Description	Test Condition/Comments	SDRAMIN = 66.8 MHz			SDRAMIN = 100 MHz			SDRAMIN = 133 MHz			Unit
			Min.	Typ.	Max.	Min.	Typ.	Max.	Min.	Typ.	Max.	
t _P	Period	Measured on rising edge at 1.5V	15		15.5	10		10.5	7.5		8.0	ns
t _H	High Time	Duration of clock cycle above 2.4V	5.2			3.0			1.87			ns
t _L	Low Time	Duration of clock cycle below 0.4V	5.0			2.0			1.67			ns

SDRAM 0:12 Clock Outputs (Lump Capacitance Test Load = 22 pF) (continued)

Parameter	Description	Test Condition/Comments	SDRAMIN = 66.8 MHz			SDRAMIN = 100 MHz			SDRAMIN = 133 MHz			Unit
			Min.	Typ.	Max.	Min.	Typ.	Max.	Min.	Typ.	Max.	
t _R	Output Rise Edge Rate	Measured from 0.4V to 2.4V	1		4	1		4	1		4	V/ns
t _F	Output Fall Edge Rate	Measured from 2.4V to 0.4V	1		4	1		4	1		4	V/ns
t _D	Duty Cycle	Measured on rising and falling edge at 1.5V	45		55	45		55	45		55	%
t _{SK}	Output Skew	Measured on rising and falling edge at 1.5V			250			250			250	ps
t _{PD}	Propagation Delay	Measured from SDRAMIN	4.5		6.0	4.5		6.0	4.5		6.0	ns
Z _o	AC Output Impedance	Average value during switching transition. Used for determining series termination value.		15			15			15		Ω

48-MHz Clock Output (Lump Capacitance Test Load = 20 pF)

Parameter	Description	Test Condition/Comments	Min.	Typ.	Max.	Unit
f	Frequency, Actual	Determined by PLL divider ratio (see m/n below)	48.008			MHz
f _D	Deviation from 48 MHz	(48.008 – 48)/48	+167			ppm
m/n	PLL Ratio	(14.31818 MHz x 57/17 = 48.008 MHz)	57/17			
t _R	Output Rise Edge Rate	Measured from 0.4V to 2.4V	0.5		2	V/ns
t _F	Output Fall Edge Rate	Measured from 2.4V to 0.4V	0.5		2	V/ns
t _D	Duty Cycle	Measured on rising and falling edge at 1.5V	45		55	%
f _{ST}	Frequency Stabilization from Power-up (cold start)	Assumes full supply voltage reached within 1 ms from power-up. Short cycles exist prior to frequency stabilization.			3	ms
Z _o	AC Output Impedance	Average value during switching transition. Used for determining series termination value.		40		Ω

24-MHz Clock Output (Lump Capacitance Test Load = 20 pF)

Parameter	Description	Test Condition/Comments	Min.	Typ.	Max.	Unit
f	Frequency, Actual	Determined by PLL divider ratio (see m/n below)	24.004			MHz
f _D	Deviation from 24 MHz	(24.004 – 24)/24	+167			ppm
m/n	PLL Ratio	(14.31818 MHz x 57/34 = 24.004 MHz)	57/34			
t _R	Output Rise Edge Rate	Measured from 0.4V to 2.4V	0.5		2	V/ns
t _F	Output Fall Edge Rate	Measured from 2.4V to 0.4V	0.5		2	V/ns
t _D	Duty Cycle	Measured on rising and falling edge at 1.5V	45		55	%
f _{ST}	Frequency Stabilization from Power-up (cold start)	Assumes full supply voltage reached within 1 ms from power-up. Short cycles exist prior to frequency stabilization.			3	ms
Z _o	AC Output Impedance	Average value during switching transition. Used for determining series termination value.		40		Ω

Ordering Information

Ordering Code	Package Type
W211BH	48-pin SSOP (300 mils)
W211BHT	48-pin SSOP (300 mils) – Tape and Reel

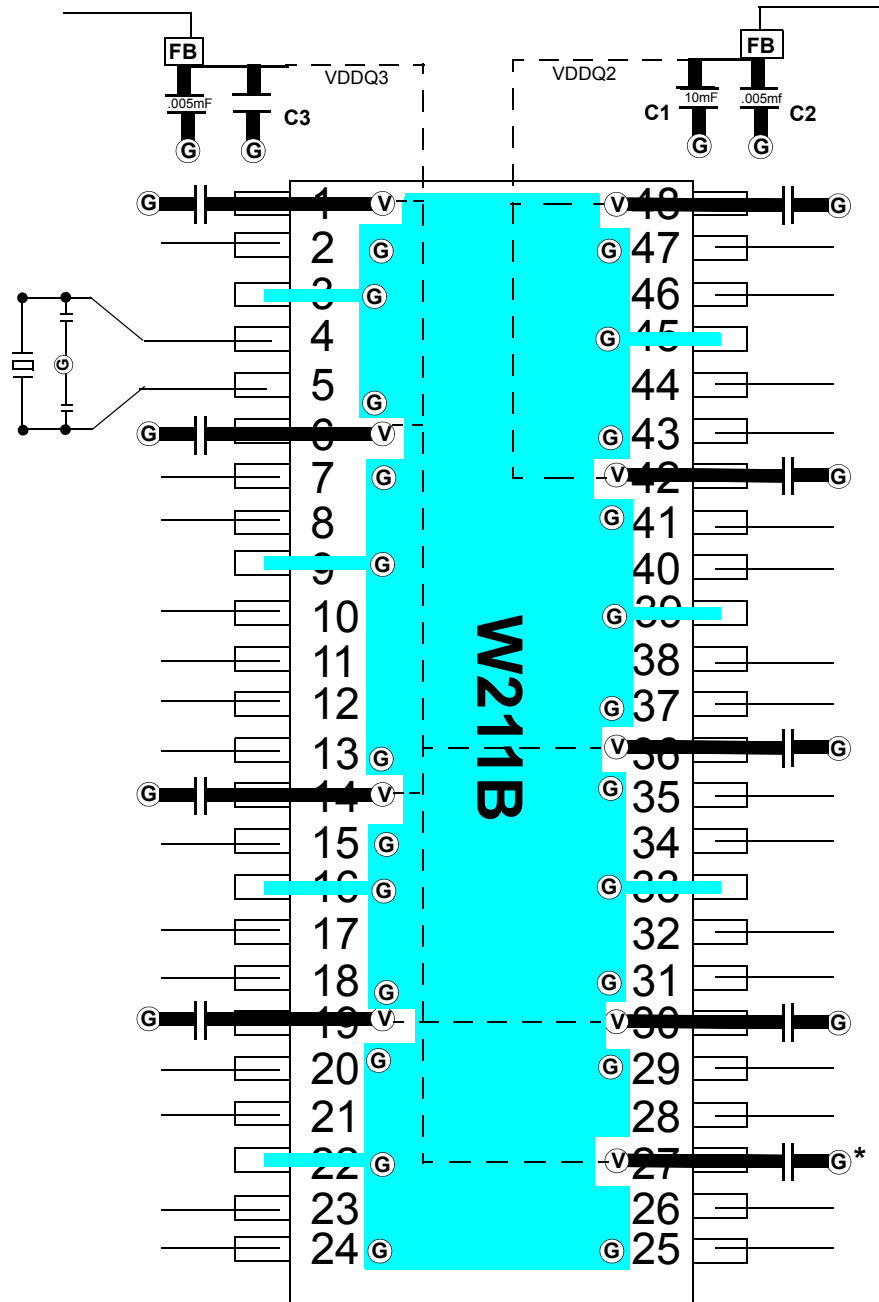
Layout Example

FB = Vishay ILB1206 - 300 (300Ω @ 100 MHz) or TDK ACB2012L-120

Ceramic Caps C1 & C3 = 10 - 22 μF C2 & C4 = .005 μF C5 = 10 μF C6 = .1 μF

ⓐ = VIA to GND plane layer Ⓥ = VIA to respective supply plane layer

Note: Each supply plane or strip should have a ferrite bead and capacitors

***Note: When using the 48 MHz for clocking video circuitry, then a 10Ω + 10 μF ceramic filter should be used on pin 27.**

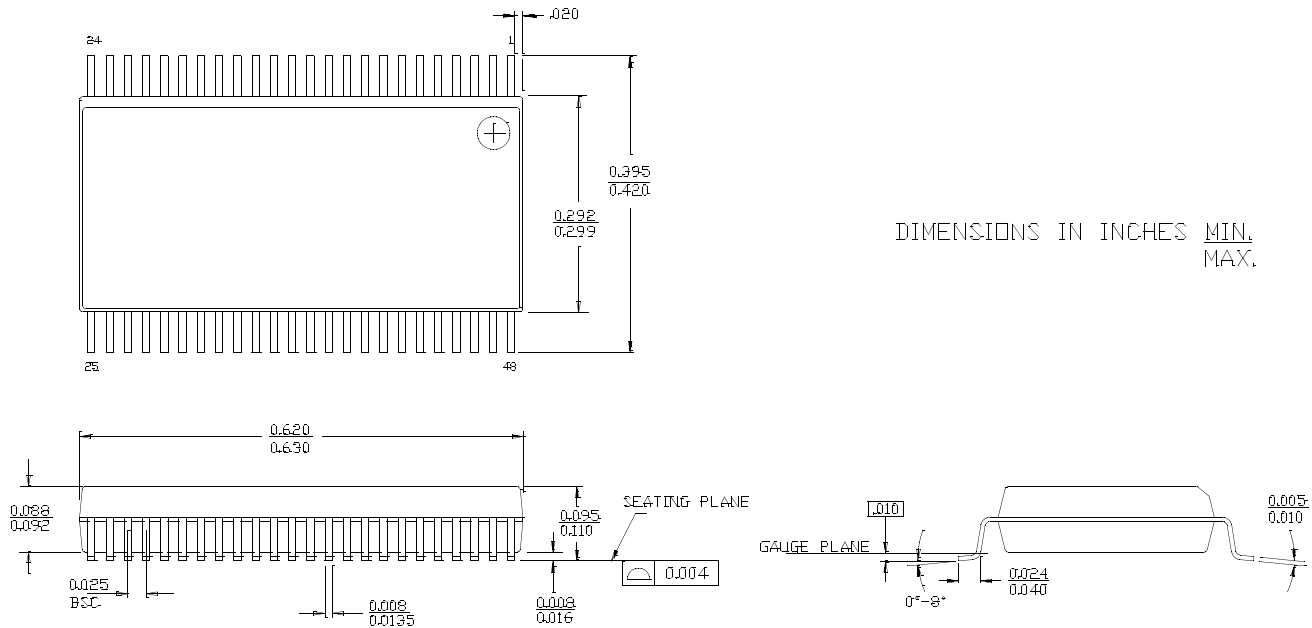
Package Drawing and Dimension
48-Lead Shrunken Small Outline Package O48

51-85061-°C

Intel and Pentium are registered trademarks of Intel Corporation. All product and company names mentioned in this document are the trademarks of their respective holders.

Document History Page

Document Title: W211B FTG for 440BX, VIA Apollo Pro-133, and ProMedia				
Document Number: 38-07174				
REV.	ECN NO.	Issue Date	Orig. of Change	Description of Change
**	110284	11/05/01	SZV	Change from Spec number: 38-00849 to 38-07174
*A	122815	12/21/02	RBI	Add Power-up Requirements to Maximum Ratings Information
*B	129738	10/03/03	RGL	Removed Preliminary
OBS	294234	See ECN	RGL	To Obsolete the DS