

### #23 CONTACT

FOR .045-.065 DIAMETER PINS ( $\delta = .008$ )  
6-FINGER, GROUP G (see page 214)

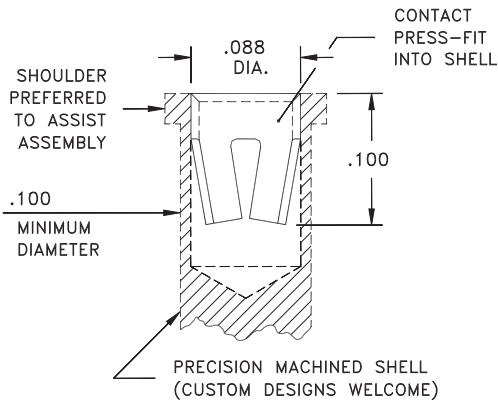

**CONTACT MATERIAL:**  
BERYLLIUM COPPER Alloy 172, Heat Treated

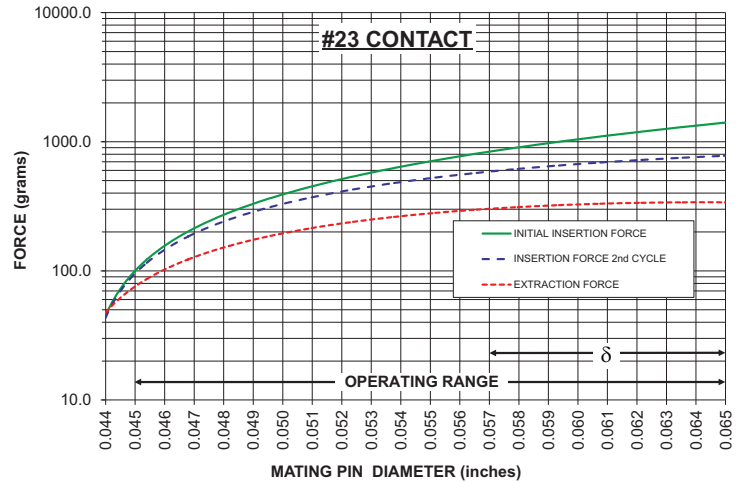

The insertion/extraction/normal force characteristics above were derived using 30 microinch gold plated contact and polished steel gauge pins having a bullet-shaped tip.

The curves represent typical average values; they are best used to compare the differences between similar size contacts and to guide you in selecting one that is suitable for your application. Your results may vary, so for your specification, we encourage you to obtain complimentary samples for your evaluation.

### #13 CONTACT

FOR .048-.064 DIAMETER PINS ( $\delta = .010$ )  
4-FINGER, GROUP G (see page 214)

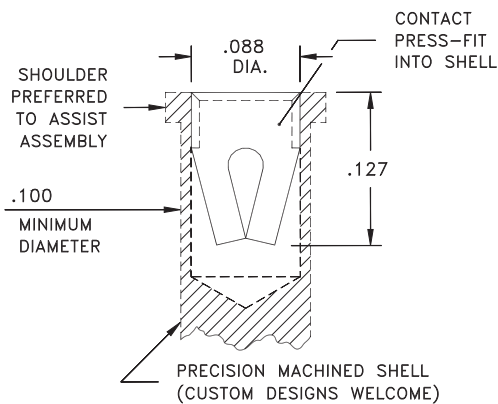

**CONTACT MATERIAL:**  
BERYLLIUM COPPER Alloy 172, Heat Treated

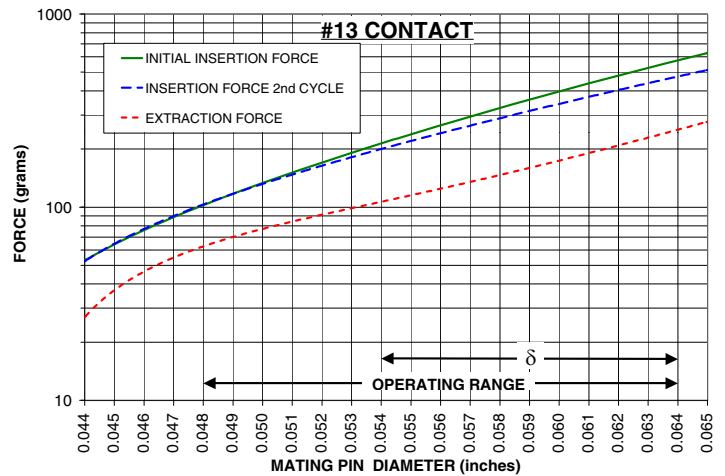

The insertion/extraction/normal force characteristics above were derived using 30 microinch gold plated contact and polished steel gauge pins having a bullet-shaped tip.

The curves represent typical average values; they are best used to compare the differences between similar size contacts and to guide you in selecting one that is suitable for your application. Your results may vary, so for your specification, we encourage you to obtain complimentary samples for your evaluation.

### #33 CONTACT

FOR .048-.064 DIAMETER PINS ( $\delta = .008$ )  
4-FINGER, GROUP G (see page 214)

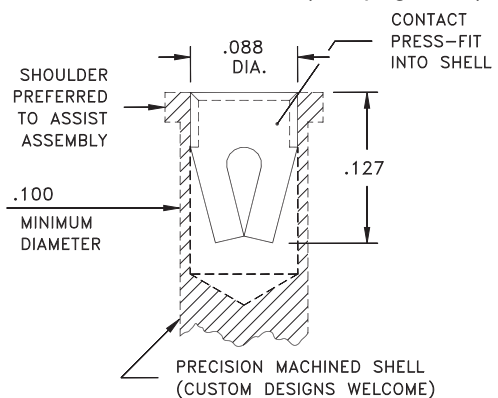

**CONTACT MATERIAL:**  
BERYLLIUM NICKEL Alloy 360, Heat Treated

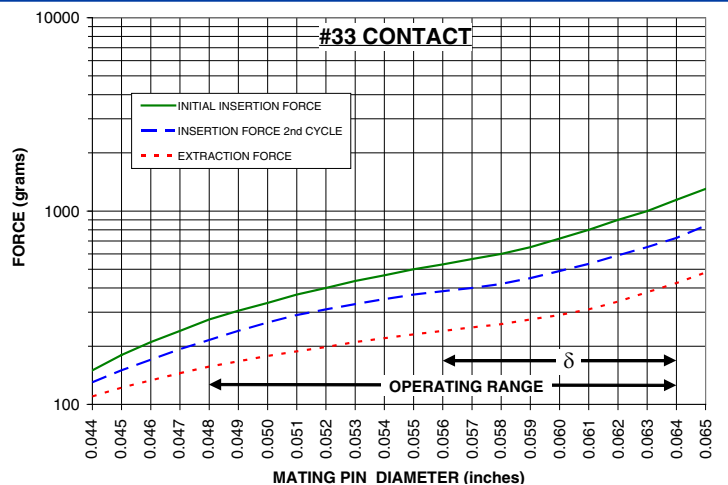

The insertion/extraction/normal force characteristics above were derived using 30 microinch gold plated contact and polished steel gauge pins having a bullet-shaped tip.

The curves represent typical average values; they are best used to compare the differences between similar size contacts and to guide you in selecting one that is suitable for your application. Your results may vary, so for your specification, we encourage you to obtain complimentary samples for your evaluation.