

## Precision Monolithic Quad SPST CMOS Analog Switches

### DESCRIPTION

The DG411 series of monolithic quad analog switches was designed to provide high speed, low error switching of precision analog signals. Combining low power (0.35  $\mu$ W) with high speed ( $t_{ON}$ : 110 ns), the DG411 family is ideally suited for portable and battery powered industrial and military applications.

To achieve high-voltage ratings and superior switching performance, the DG411 series was built on Vishay Siliconix's high voltage silicon gate process. An epitaxial layer prevents latchup.

Each switch conducts equally well in both directions when on, and blocks input voltages up to the supply levels when off.

The DG411, DG412 respond to opposite control logic as shown in the Truth Table. The DG413 has two normally open and two normally closed switches.

### FEATURES

- 44 V supply max. rating
- $\pm 15$  V analog signal range
- On-resistance -  $R_{DS(on)}$ : 25  $\Omega$
- Fast switching -  $t_{ON}$ : 110 ns
- Ultra low power -  $P_D$ : 0.35  $\mu$ W
- TTL, CMOS compatible
- Single supply capability

### BENEFITS

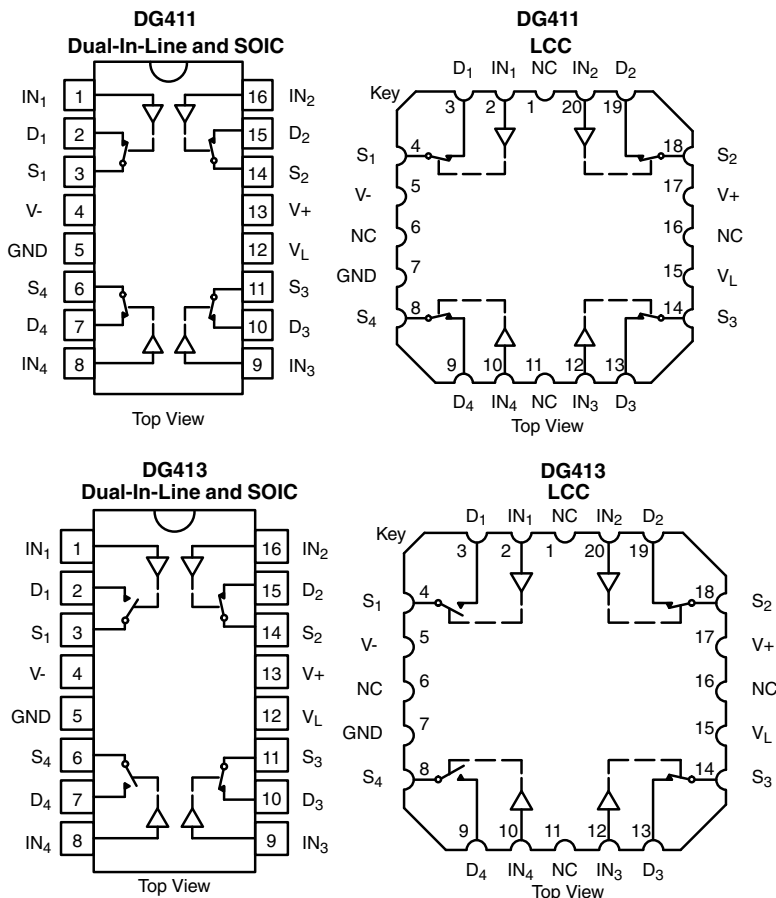
- Widest dynamic range
- Low signal errors and distortion
- Break-before-make switching action
- Simple interfacing

### APPLICATIONS

- Precision automatic test equipment
- Precision data acquisition
- Communication systems
- Battery powered systems
- Computer peripherals



### FUNCTIONAL BLOCK DIAGRAM AND PIN CONFIGURATION



TRUTH TABLE		
Logic	DG411	DG412
0	ON	OFF
1	OFF	ON

Logic "0"  $\leq 0.8$  V  
 Logic "1"  $\geq 2.4$  V

TRUTH TABLE		
Logic	SW <sub>1</sub> , SW <sub>4</sub>	SW <sub>2</sub> , SW <sub>3</sub>
0	OFF	ON
1	ON	OFF

Logic "0"  $\leq 0.8$  V  
 Logic "1"  $\geq 2.4$  V

\* Pb containing terminations are not RoHS compliant, exemptions may apply

ORDERING INFORMATION		
Temp. Range	Package	Part Number
<b>DG411, DG412</b>		
- 40 °C to 85 °C	16-Pin Plastic DIP	DG411DJ DG411DJ-E3
- 40 °C to 85 °C		16-Pin Narrow SOIC
	DG411DY DG411DY-E3 DG411DY-T1 DG411DY-T1-E3	
		DG412DY DG412DY-E3 DG412DY-T1 DG412DY-T1-E3
<b>DG413</b>		
- 40 °C to 85 °C	16-Pin Plastic DIP	DG413DJ DG413DJ-E3
	16-Pin Narrow SOIC	DG413DY DG413DY-E3 DG413DY-T1 DG413DY-T1-E3

ABSOLUTE MAXIMUM RATINGS			
Parameter	Limit	Unit	
V+ to V-	44	V	
GND to V-	25		
V <sub>L</sub>	(GND - 0.3) to (V+) + 0.3		
Digital Inputs <sup>a</sup> , V <sub>S</sub> , V <sub>D</sub>	(V-) -2 to (V+) + 2 or 30 mA, whichever occurs first		
Continuous Current (Any terminal)	30	mA	
Peak Current, S or D (Pulsed at 1 ms, 10 % duty cycle)	100		
Storage Temperature	(AK, AZ Suffix)	- 65 to 150	°C
	(DJ, DY Suffix)	- 65 to 125	
Power Dissipation (Package) <sup>b</sup>	16-Pin Plastic DIP <sup>c</sup>	470	mW
	16-Pin Narrow SOIC <sup>d</sup>	600	
	16-Pin CerDIP <sup>e</sup>	900	
	LCC-20 <sup>e</sup>	900	

Notes:

- a. Signals on S<sub>X</sub>, D<sub>X</sub>, or IN<sub>X</sub> exceeding V+ or V- will be clamped by internal diodes. Limit forward diode current to maximum current ratings.
- b. All leads welded or soldered to PC board.
- c. Derate 6 mW/°C above 25 °C.
- d. Derate 7.6 mW/°C above 75 °C.
- e. Derate 12 mW/°C above 75 °C.



SPECIFICATIONS <sup>a</sup>									
Parameter	Symbol	Test Conditions Unless Specified V <sub>+</sub> = 15 V, V <sub>-</sub> = - 15 V V <sub>L</sub> = 5 V, V <sub>IN</sub> = 2.4 V, 0.8 V <sup>f</sup>	Temp. <sup>b</sup>	Typ. <sup>c</sup>	A Suffix - 55 °C to 125 °C		D Suffix - 40 °C to 85 °C		Unit
					Min. <sup>d</sup>	Max. <sup>d</sup>	Min. <sup>d</sup>	Max. <sup>d</sup>	
<b>Analog Switch</b>									
Analog Signal Range <sup>e</sup>	V <sub>ANALOG</sub>		Full		- 15	15	- 15	15	V
Drain-Source On-Resistance	R <sub>DS(on)</sub>	V <sub>+</sub> = 13.5 V, V <sub>-</sub> = - 13.5 V I <sub>S</sub> = - 10 mA, V <sub>D</sub> = ± 8.5 V	Room Full	25		35 45		35 45	Ω
Switch Off Leakage Current	I <sub>S(off)</sub>	V <sub>+</sub> = 16.5 V, V <sub>-</sub> = - 16.5 V V <sub>D</sub> = ± 15.5 V, V <sub>S</sub> = ± 15.5 V	Room Full	± 0.1	- 0.25 - 20	0.25 20	- 0.25 - 5	0.25 5	nA
	I <sub>D(off)</sub>		Room Full	± 0.1	- 0.25 - 20	0.25 20	- 0.25 - 5	0.25 5	
Channel On Leakage Current	I <sub>D(on)</sub>	V <sub>+</sub> = 16.5 V, V <sub>-</sub> = - 16.5 V V <sub>S</sub> = V <sub>D</sub> = ± 15.5 V	Room Full	± 0.1	- 0.4 - 40	0.4 40	- 0.4 - 10	0.4 10	
<b>Digital Control</b>									
Input Current, V <sub>IN</sub> Low	I <sub>IL</sub>	V <sub>IN</sub> under test = 0.8 V	Full	0.005	- 0.5	0.5	- 0.5	0.5	μA
Input Current, V <sub>IN</sub> High	I <sub>IH</sub>	V <sub>IN</sub> under test = 2.4 V	Full	0.005	- 0.5	0.5	- 0.5	0.5	
<b>Dynamic Characteristics</b>									
Turn-On Time	t <sub>ON</sub>	R <sub>L</sub> = 300 Ω, C <sub>L</sub> = 35 pF V <sub>S</sub> = ± 10 V, see figure 2	Room Full	110		175 240		175 220	ns
Turn-Off Time	t <sub>OFF</sub>		Room Full	100		145 160		145 160	
Break-Before-Make Time Delay	t <sub>D</sub>	DG413 only, V <sub>S</sub> = 10 V R <sub>L</sub> = 300 Ω, C <sub>L</sub> = 35 pF	Room	25					
Charge Injection	Q	V <sub>g</sub> = 0 V, R <sub>g</sub> = 0 Ω C <sub>L</sub> = 10 nF	Room	5					pC
Off Isolation <sup>e</sup>	OIRR	R <sub>L</sub> = 50 Ω, C <sub>L</sub> = 5 pF, f = 1 MHz	Room	68					dB
Channel-to-Channel Crosstalk <sup>e</sup>	X <sub>TALK</sub>		Room	85					
Source Off Capacitance <sup>e</sup>	C <sub>S(off)</sub>	f = 1 MHz	Room	9					pF
Drain Off Capacitance <sup>e</sup>	C <sub>D(off)</sub>		Room	9					
Channel On Capacitance <sup>e</sup>	C <sub>D(on)</sub>		Room	35					
<b>Power Supplies</b>									
Positive Supply Current	I <sub>+</sub>	V <sub>+</sub> = 16.5 V, V <sub>-</sub> = - 16.5 V V <sub>IN</sub> = 0 or 5 V	Room Full	0.0001		1 5		1 5	μA
Negative Supply Current	I <sub>-</sub>		Room Full	- 0.0001	- 1 - 5		- 1 - 5		
Logic Supply Current	I <sub>L</sub>		Room Full	0.0001		1 5		1 5	
Ground Current	I <sub>GND</sub>		Room Full	- 0.0001	- 1 - 5		- 1 - 5		

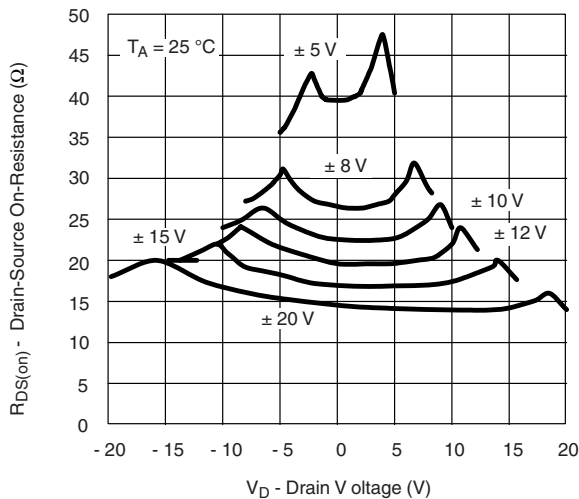
SPECIFICATIONS <sup>a</sup> (for Unipolar Supplies)									
Parameter	Symbol	Test Conditions Unless Specified V <sub>+</sub> = 12 V, V <sub>-</sub> = 0 V V <sub>L</sub> = 5 V, V <sub>IN</sub> = 2.4 V, 0.8 V <sup>f</sup>	Temp. <sup>b</sup>	Typ. <sup>c</sup>	A Suffix - 55 °C to 125 °C		D Suffix - 40 °C to 85 °C		Unit
					Min. <sup>d</sup>	Max. <sup>d</sup>	Min. <sup>d</sup>	Max. <sup>d</sup>	
<b>Analog Switch</b>									
Analog Signal Range <sup>e</sup>	V <sub>ANALOG</sub>		Full			12		12	V
Drain-Source On-Resistance	R <sub>DS(on)</sub>	V <sub>+</sub> = 10.8 V, I <sub>S</sub> = - 10 mA, V <sub>D</sub> = 3 V, 8 V	Room Full	40		80 100		80 100	Ω
<b>Dynamic Characteristics</b>									
Turn-On Time	t <sub>ON</sub>	R <sub>L</sub> = 300 Ω, C <sub>L</sub> = 35 pF V <sub>S</sub> = 8 V, see figure 2	Room Hot	175		250 400		250 315	ns
Turn-Off Time	t <sub>OFF</sub>		Room Hot	95		125 140		125 140	
Break-Before-Make Time Delay	t <sub>D</sub>	DG413 only, V <sub>S</sub> = 8 V R <sub>L</sub> = 300 Ω, C <sub>L</sub> = 35 pF	Room	25					
Charge Injection	Q	V <sub>g</sub> = 6 V, R <sub>g</sub> = 0 Ω, C <sub>L</sub> = 10 nF	Room	25					pC
<b>Power Supplies</b>									
Positive Supply Current	I <sub>+</sub>	V <sub>+</sub> = 13.5 V, V <sub>IN</sub> = 0 or 5 V	Room Hot	0.0001		1 5		1 5	μA
Negative Supply Current	I <sub>-</sub>		Room Hot	- 0.0001	- 1 - 5		- 1 - 5		
Logic Supply Current	I <sub>L</sub>		Room Hot	0.0001		1 5		1 5	
Ground Current	I <sub>GND</sub>		Room Hot	- 0.0001	- 1 - 5		- 5		

**Notes:**

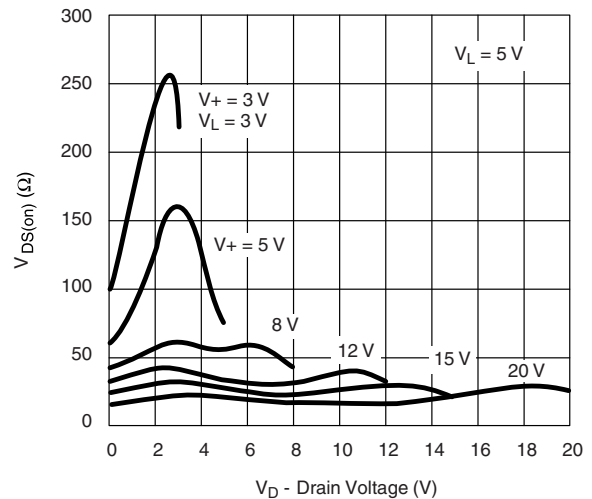
- a. Refer to process option flowchart.
- b. Room = 25 °C, Full = as determined by the operating temperature suffix.
- c. Typical values are for DESIGN AID ONLY, not guaranteed nor subject to production testing.
- d. The algebraic convention whereby the most negative value is a minimum and the most positive a maximum, is used in this data sheet.
- e. Guaranteed by design, not subject to production test.
- f. V<sub>IN</sub> = input voltage to perform proper function.

Stresses beyond those listed under "Absolute Maximum Ratings" may cause permanent damage to the device. These are stress ratings only, and functional operation of the device at these or any other conditions beyond those indicated in the operational sections of the specifications is not implied. Exposure to absolute maximum rating conditions for extended periods may affect device reliability.

**TYPICAL CHARACTERISTICS (25 °C, unless otherwise noted)**

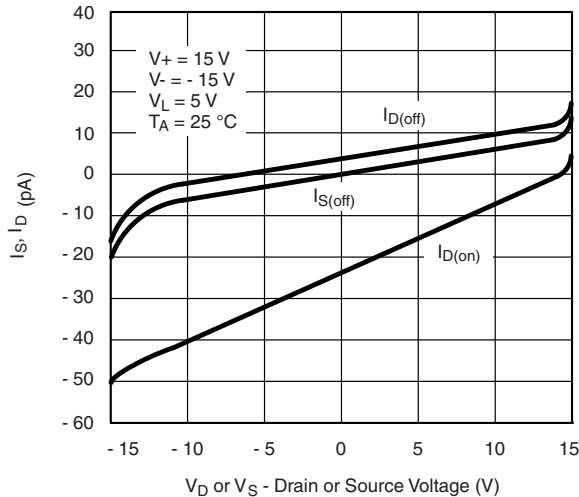


**On-Resistance vs. V<sub>D</sub> and Power Supply Voltage**

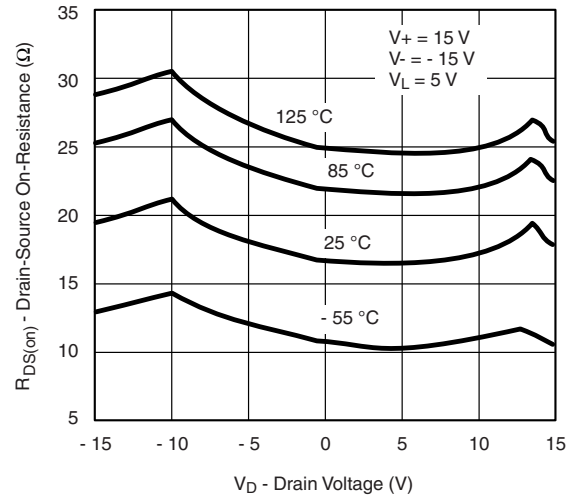


**On-Resistance vs. V<sub>D</sub> and Unipolar Supply Voltage**

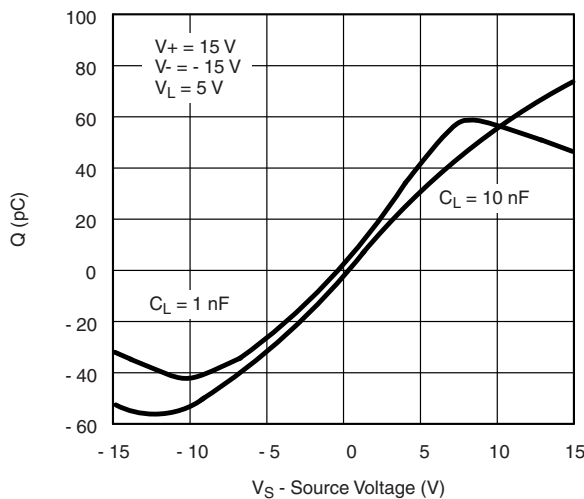
## TYPICAL CHARACTERISTICS (25 °C, unless otherwise noted)



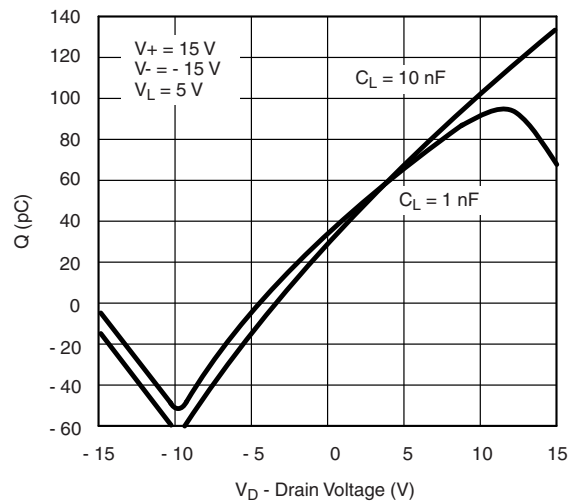
**Leakage Current vs. Analog Voltage**



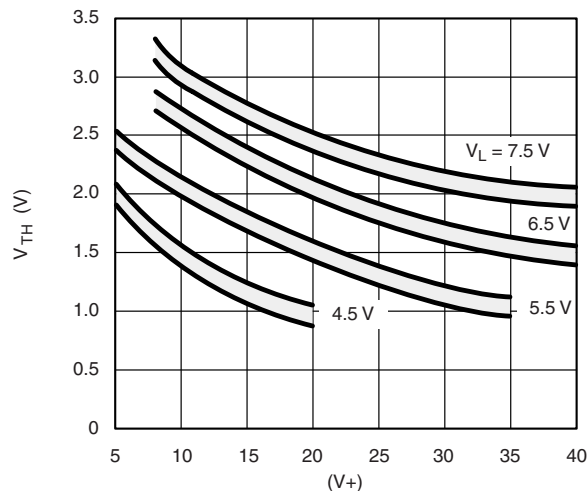
**$I_D, I_S$  Leakages vs. Temperature**



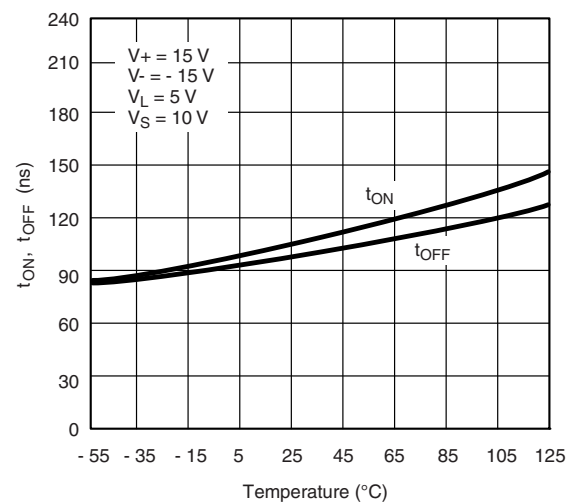
**Charge Injection vs. Analog Voltage**



**Charge Injection vs. Analog Voltage**

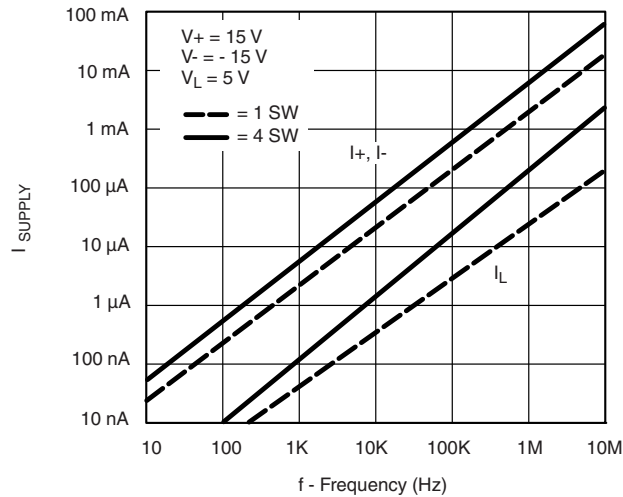


**Input Switching Threshold vs. Supply Voltage**



**Switching Time vs. Temperature**

## TYPICAL CHARACTERISTICS (25 °C, unless otherwise noted)



Supply Current vs. Input Switching Frequency

## SCHEMATIC DIAGRAM (Typical Channel)

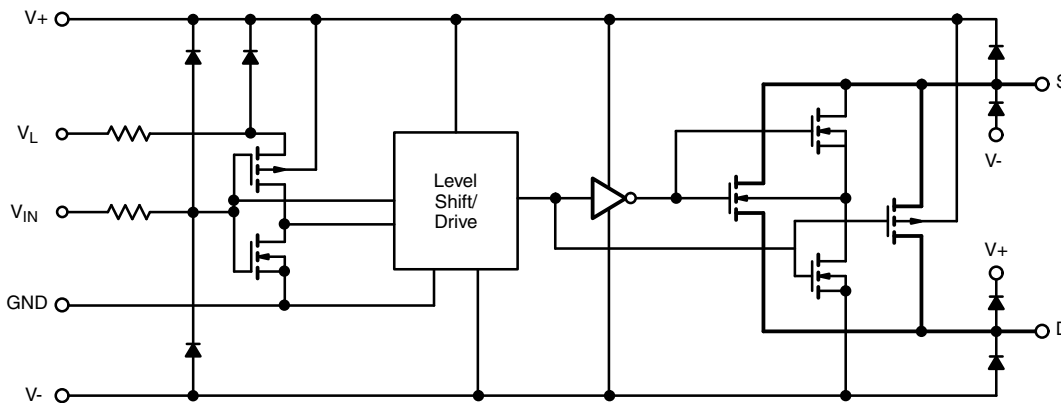
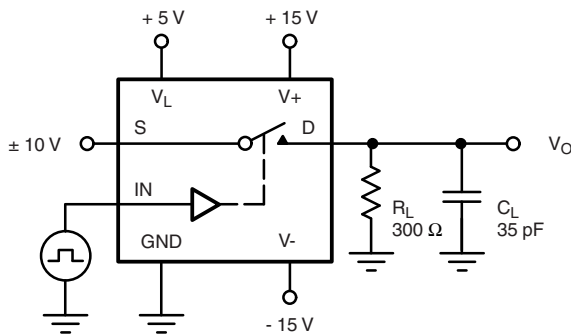


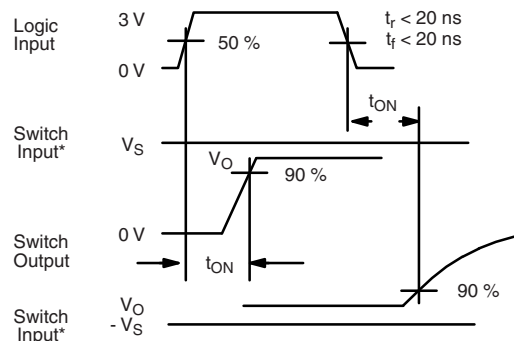
Figure 1.

## TEST CIRCUITS



$C_L$  (includes fixture and stray capacitance)

$$V_O = V_S \frac{R_L}{R_L + r_{DS(on)}}$$

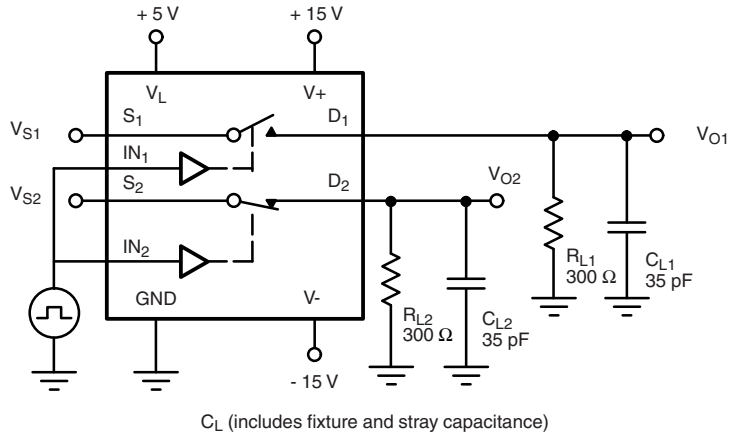


\*  $V_S = 10\text{ V}$  for  $t_{ON}$ ,  $V_S = -10\text{ V}$  for  $t_{OFF}$

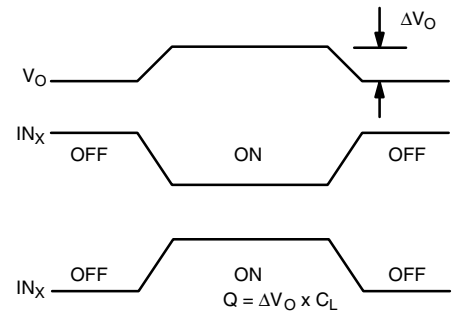
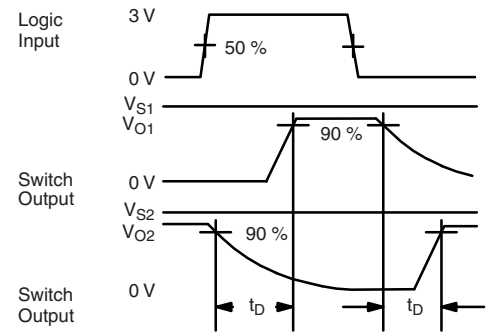
Note: Logic input waveform is inverted for switches that have the opposite logic sense control

Figure 2. Switching Time

## TEST CIRCUITS

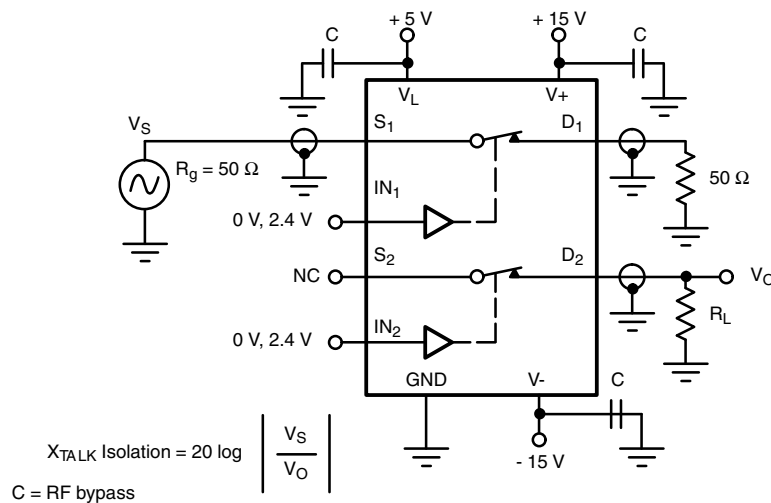


**Figure 3. Break-Before-Make (DG413)**



$IN_X$  dependent on switch configuration Input polarity determined by sense of switch.

**Figure 4. Charge Injection**



**Figure 5. Crosstalk**

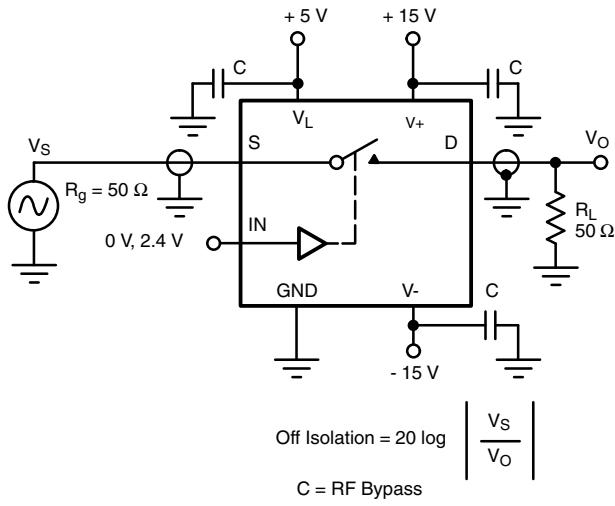


Figure 6. Off Isolation

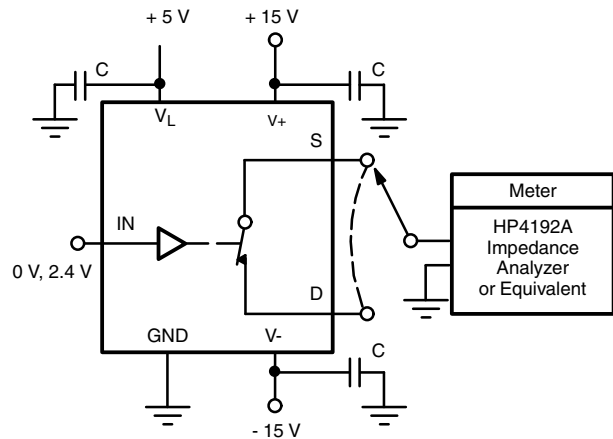


Figure 7. Source/Drain Capacitances

## APPLICATIONS

### Single Supply Operation:

The DG411, DG412, DG413 can be operated with unipolar supplies from 5 V to 44 V. These devices are characterized and tested for unipolar supply operation at 12 V to facilitate the majority of applications. In single supply operation, V+ is tied to VL and V- is tied to 0 V. See Input Switching Threshold vs. Supply Voltage curve for VL versus input threshold requirements.

### Summing Amplifier

When driving a high impedance, high capacitance load such as shown in figure 8, where the inputs to the summing amplifier have some noise filtering, it is necessary to have shunt switches for rapid discharge of the filter capacitor, thus preventing offsets from occurring at the output.

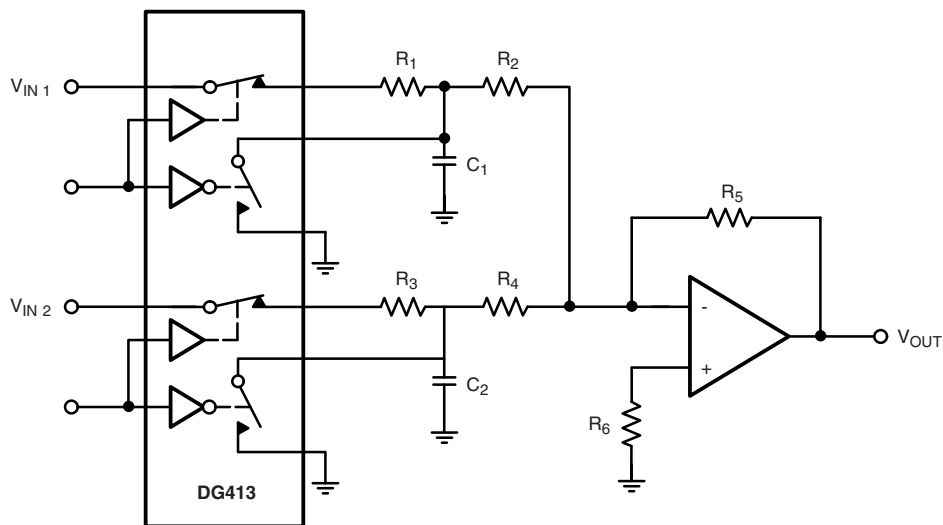


Figure 8. Summing Amplifier

Vishay Siliconix maintains worldwide manufacturing capability. Products may be manufactured at one of several qualified locations. Reliability data for Silicon Technology and Package Reliability represent a composite of all qualified locations. For related documents such as package/tape drawings, part marking, and reliability data, see [www.vishay.com/ppg?70050](http://www.vishay.com/ppg?70050).





## Disclaimer

ALL PRODUCT, PRODUCT SPECIFICATIONS AND DATA ARE SUBJECT TO CHANGE WITHOUT NOTICE TO IMPROVE RELIABILITY, FUNCTION OR DESIGN OR OTHERWISE.

Vishay Intertechnology, Inc., its affiliates, agents, and employees, and all persons acting on its or their behalf (collectively, "Vishay"), disclaim any and all liability for any errors, inaccuracies or incompleteness contained in any datasheet or in any other disclosure relating to any product.

Vishay makes no warranty, representation or guarantee regarding the suitability of the products for any particular purpose or the continuing production of any product. To the maximum extent permitted by applicable law, Vishay disclaims (i) any and all liability arising out of the application or use of any product, (ii) any and all liability, including without limitation special, consequential or incidental damages, and (iii) any and all implied warranties, including warranties of fitness for particular purpose, non-infringement and merchantability.

Statements regarding the suitability of products for certain types of applications are based on Vishay's knowledge of typical requirements that are often placed on Vishay products in generic applications. Such statements are not binding statements about the suitability of products for a particular application. It is the customer's responsibility to validate that a particular product with the properties described in the product specification is suitable for use in a particular application. Parameters provided in datasheets and/or specifications may vary in different applications and performance may vary over time. All operating parameters, including typical parameters, must be validated for each customer application by the customer's technical experts. Product specifications do not expand or otherwise modify Vishay's terms and conditions of purchase, including but not limited to the warranty expressed therein.

Except as expressly indicated in writing, Vishay products are not designed for use in medical, life-saving, or life-sustaining applications or for any other application in which the failure of the Vishay product could result in personal injury or death. Customers using or selling Vishay products not expressly indicated for use in such applications do so at their own risk and agree to fully indemnify and hold Vishay and its distributors harmless from and against any and all claims, liabilities, expenses and damages arising or resulting in connection with such use or sale, including attorneys fees, even if such claim alleges that Vishay or its distributor was negligent regarding the design or manufacture of the part. Please contact authorized Vishay personnel to obtain written terms and conditions regarding products designed for such applications.

No license, express or implied, by estoppel or otherwise, to any intellectual property rights is granted by this document or by any conduct of Vishay. Product names and markings noted herein may be trademarks of their respective owners.