

SERIES 1660 - SINGLE AND DOUBLE-POLE PUSHBUTTON SWITCHES

TO 16 (4) A 250 V AC



PRODUCT FEATURES

- ◆ Illuminated and non-illuminated pushbutton switches
- ◆ Proven jump contact switching system (double interrupting)
- ◆ Opening and closing speed independent of the actuating speed
- ◆ Product-dependent with external lamp terminal

ON REQUEST

- ◆ Other colors
- ◆ Other printing variants
- ◆ Other terminal types
- ◆ Other lamp variants
- ◆ Cable assembly

Mechanical life endurance	5E4
Contact resistance (new condition)	< 100 mOhm (1 A 12 V DC)
Insulation resistance (new condition)	> 100 MOhm (500 V DC)
Proof tracking	250 PTI
Protection type	IP 40
Ambient temperature	terminal side -20 °C ... +85 °C actuating side -20 °C ... +55 °C
Flammability	UL 94 V-2
Glow wire test temperature	850 °C
Material	actuator housing terminals
	PC (product-dependent) / PA PA / PA glass fiber-reinforced (product-dependent) Cu
Plug force of the terminals	≤ 80 N
Approval marks	Ⓢ / Ⓡ (product-dependent) / Ⓢ / Ⓢ
Suitable for appliances of protection class II	



ROCKER SWITCHES

PUSHBUTTON SWITCHES

TOGGLE SWITCHES

SLIDE SWITCHES

ROTARY SWITCHES

FOOT SWITCHES

TACT AND KEY SWITCHES







































SNAP-ACTION SWITCHES

MICRO-SIGNAL SWITCHES

SENSORS

SERIES 1660 - SINGLE AND DOUBLE-POLE PUSHBUTTON SWITCHES

TO 16 (4) A 250 V AC

 single-pole	Lighting voltage in V	Actuator color / printing	Housing color	Rating				Terminal type	Terminal description	Contact distance in mm	Contact material	Miscellaneous	Stock version
				16 (4) A 250 V AC 1E4	16 (4) A 250 V AC	12 (4) A 250 V AC 1E4	12 A 250 V AC 1/2 HP						
Normally open contact (SPNO)													
1665.3102	230			●				 6.3 / 2 x 4.8	≥ 3	Ag	external lamp terminal		
ON / OFF switch (SPST)													
1662.0201				●				 6.3	≥ 3	Ag			
Normally open contact (SPNO)													
1662.0101				●				 6.3	≥ 3	Ag		●	
Changeover switch (SPDT momentary)													
1664.0101					●			 4.8	< 3	Ag			
double-pole													
 double-pole	Lighting voltage in V	Actuator color / printing	Housing color	Rating				Terminal type	Terminal description	Contact distance in mm	Contact material	Miscellaneous	Stock version
				16 (4) A 250 V AC 1E4	16 (4) A 250 V AC	12 (4) A 250 V AC 1E4	12 A 250 V AC 1/2 HP						
ON / OFF switch (DPST)													
1660.0201	230			●				 6.3	≥ 3	Ag		●	
1660.0202	230			●				 6.3	≥ 3	Ag		●	
1660.3202	230			●				 6.3 / 2 x 4.8	≥ 3	Ag	external lamp terminal		
1660.0222	110						●	 6.3	≥ 3	Ag			
1661.0220					●	●	●	 6.3	≥ 3	Ag			
Normally open contact (DPNO)													
1661.0101				●				 6.3	≥ 3	Ag		●	
Changeover switch (DPDT)													
1663.0201					●			 4.8	< 3	Ag			
Changeover switch (DPDT momentary)													
1663.0101					●			 4.8	< 3	Ag		●	

ROCKER SWITCHES

PUSHBUTTON SWITCHES

TOGGLE SWITCHES

SLIDE SWITCHES

ROTARY SWITCHES

FOOT SWITCHES

TACT AND KEY SWITCHES











SNAP-ACTION SWITCHES

MICRO-SIGNAL SWITCHES

SENSORS

SERIES 1660 - SINGLE AND DOUBLE-POLE PUSHBUTTON SWITCHES

TO 16 (4) A 250 V AC

	Lamp	Lighting voltage in V	Actuator color / printing	Housing color	16 (4) A 250 V AC 1E4	16 (4) A 250 V AC	12 (4) A 250 V AC 1E4	12 A 250 V AC 1/2 HP	12 A 125 V AC 1/6 HP	Terminal type	Terminal description	Contact distance in mm	Contact material	Miscellaneous	Stock version
															
	Lamp														
	1667.0101	230									6.3				
	1667.0102	230									6.3				
	1667.0104	230									6.3				



Basic types 1660, 1661 and 1663
double-pole
illuminated / non-illuminated

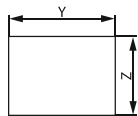

X = wall thickness

X	Y	Z
0.75 ... 1.0	30 +0.1	22.2 +0.2
1.0 ... 1.5	30.2 +0.1	22.2 +0.2
1.5 ... 3.0	30.4 +0.1	22.2 +0.2

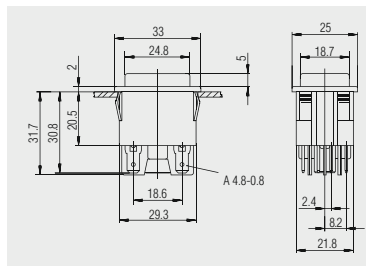

Quick-connect terminal
4.8 x 0.8

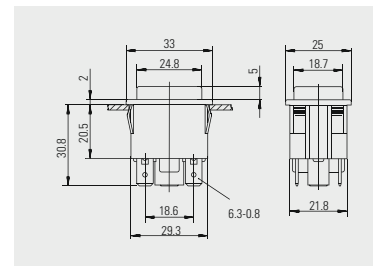

Quick-connect terminal
6.3 x 0.8

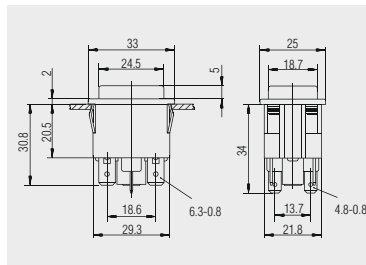

Quick-connect terminal
6.3 x 0.8 / 2 x 4.8 x 0.8
with external lamp terminal

ROCKER SWITCHES

PUSHBUTTON SWITCHES

TOGGLE SWITCHES

SLIDE SWITCHES

ROTARY SWITCHES

FOOT SWITCHES

TACT AND KEY SWITCHES

SNAP-ACTION SWITCHES

MICRO-SIGNAL SWITCHES

SENSORS

SERIES 1660 - SINGLE AND DOUBLE-POLE PUSHBUTTON SWITCHES

TO 16 (4) A 250 V AC

ROCKER SWITCHES

PUSHBUTTON SWITCHES

TOGGLE SWITCHES

SLIDE SWITCHES

ROTARY SWITCHES

FOOT SWITCHES

TACT AND KEY SWITCHES

SNAP-ACTION SWITCHES

MICRO-SIGNAL SWITCHES

SENSORS



Basic type 1667 lamp

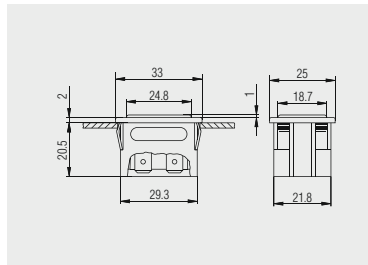

Quick-connect terminal 6.3 x 0.8

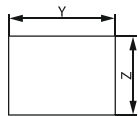

X = wall thickness

X	Y	Z
0.75 ... 1.0	30 ^{+0.1}	22.2 ^{+0.2}
1.0 ... 1.5	30.2 ^{+0.1}	22.2 ^{+0.2}
1.5 ... 3.0	30.4 ^{+0.1}	22.2 ^{+0.2}



Gasket 340.040.011

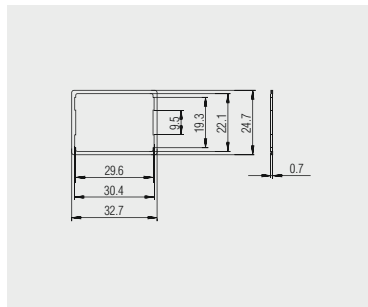

Gasket of EPDM black for sealing between switch and appliance for increased dust and water protection.



Protection cap 203.201.011

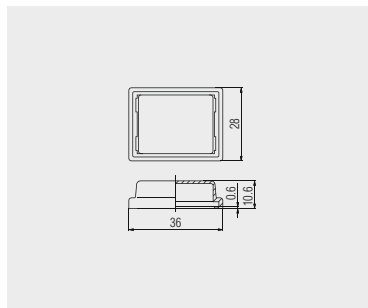

Transparent PVC - protection cap for switches of the basic types 1660, 1662, 1663, 1664, 1665 and 1667. Serves as dust and water protection of the actuation side.



Dummy piece 203.028.013

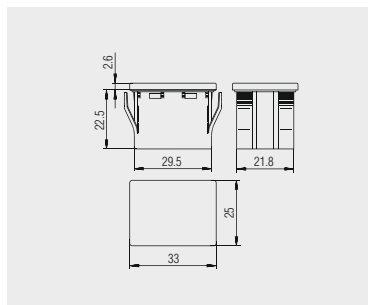

Dummy piece for size of basic type 1667 of PA with housing and cover in black and with mounted gasket (340.040.011) for dust and water protection.