



Product Description

RFMD's STA-5063Z is a general purpose class A linear amplifier which utilizes InGaP GaAs Heterojunction Bipolar Transistor (HBT) amplifier housed in a low-cost surface-mountable plastic package. This product is specifically designed as a driver amplifier for WLAN 802.11a and 5.8GHz ISM band and 3.3GHz to 3.8GHz fixed wireless applications. It can run from a fixed 3.0V to 3.6V supply with its on-chip active bias network which includes a power up and down control. On-chip impedance matching circuitry provides a 50Ω nominal RF input and output impedance. Its high linearity makes it an ideal choice for multicarrier and digital applications. Housed in an industry standard SOT-363 package, it has no blind solder joints and designed for low cost. This product is offered in a RoHS Compliant and Green package with matte tin finish, designated by the "Z" package suffix.

Optimum Technology Matching® Applied

- GaAs HBT
- GaAs MESFET
- InGaP HBT
- SiGe BiCMOS
- Si BiCMOS
- SiGe HBT
- GaAs pHEMT
- Si CMOS
- Si BJT
- GaN HEMT
- InP HBT
- BiFET HBT
- LDMOS

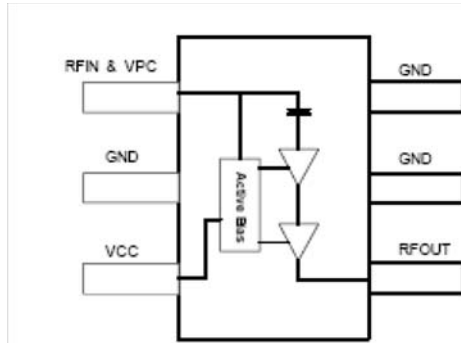

Features

- Linear Class A Performance
- P_{1dB} = 17.5dBm at 3.5GHz
- P_{1dB} = 15dBm at 5.9GHz
- IP₃ = 30dBm at 3.5GHz
- IP₃ = 27dBm at 5.9GHz
- Power Up/Down Control < 1uS
- Active Bias Controlled
- Robust Class 1C ESD Rating

Applications

- Driver Stage for 802.11a Access Points
- Wimax 802.16 Driver Stage
- Low Power 5.8GHz ISM Output Stage
- Fixed Wireless, UNII Driver Stage

Parameter	Specification			Unit	Condition
	Min.	Typ.	Max.		
Small Signal Gain	17.5	19.0	21.0	dB	3.5GHz with 3GHz app circuit
	13.2	14.7	16.7	dB	5.1GHz with 5GHz app circuit
	12.5	14.0	16.0	dB	5.9GHz with 5GHz app circuit
Output Power at 1dB Compression		17.5		dBm	3.5GHz with 3GHz app circuit
		15.0		dBm	5.1GHz with 5GHz app circuit
	13.5	15.0		dBm	5.9GHz with 5GHz app circuit
Output Third Order Intercept Point	28.0	30.0		dBm	3.5GHz
	25.0	27.0		dBm	5.9GHz
Frequency of Operation	3.3		6.2	GHz	
Noise Figure		9.0	10.5	dB	5.9GHz
Input VSWR		1.5	2.0		5.1GHz to 5.9GHz for 5GHz app circuit
Output VSWR		2.0	2.6		5.1GHz to 5.9GHz for 5GHz app circuit
Total Device Current	42.0	52.0	62.0	mA	
Thermal Resistance		150		°C/W	junction to backside

Test Conditions: Evaluation Board, Z₀ = 50Ω, V_{CC} = 3.3V, I_Q = 52mA, T = 25°C

Absolute Maximum Ratings

Parameter	Rating	Unit
Max Device Current (I_D)	80	mA
ESD Rating (HBM)	1000	V
Total Device Current (I)	80	mA
Device Voltage (Pins 1 and 3)	4	V
Device Voltage (Pin 4)	5.5	V
Max RF Input Power	15	dBm
Power Dissipation	0.40	W
Max Junction Temperature (T_J)	150	°C
Operating Temperature Range (T_L)	-40 to + 85	°C
Max Storage Temperature	-40 to + 150	°C



Caution! ESD sensitive device.

Exceeding any one or a combination of the Absolute Maximum Rating conditions may cause permanent damage to the device. Extended application of Absolute Maximum Rating conditions to the device may reduce device reliability. Specified typical performance or functional operation of the device under Absolute Maximum Rating conditions is not implied.

RoHS status based on EU Directive 2002/95/EC (at time of this document revision).

The information in this publication is believed to be accurate and reliable. However, no responsibility is assumed by RF Micro Devices, Inc. ("RFMD") for its use, nor for any infringement of patents, or other rights of third parties, resulting from its use. No license is granted by implication or otherwise under any patent or patent rights of RFMD. RFMD reserves the right to change component circuitry, recommended application circuitry and specifications at any time without prior notice.

Operation of this device beyond any one of these limits may cause permanent damage. For reliable continuous operation, the device voltage and current must not exceed the maximum operating values specified in the table on page one.

Bias Conditions should also satisfy the following expression:

$$I_D V_D < (T_J - T_L) / R_{TH, j-H}$$

Simplified Device Schematic

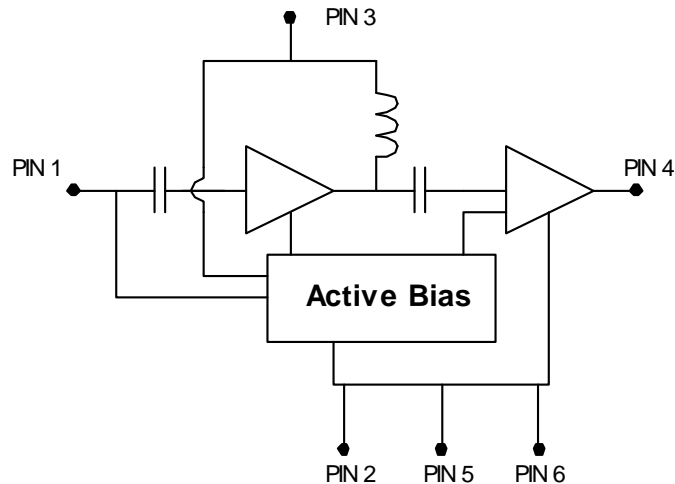

5.1GHz to 5.9GHz Evaluation Board Data ($V_{CC}=V_{BIAS}=3.3V$, $I_q=52mA$)

Wide Band Gain and Return Loss vs Freq at Vs=3.3V, Tbp=25C

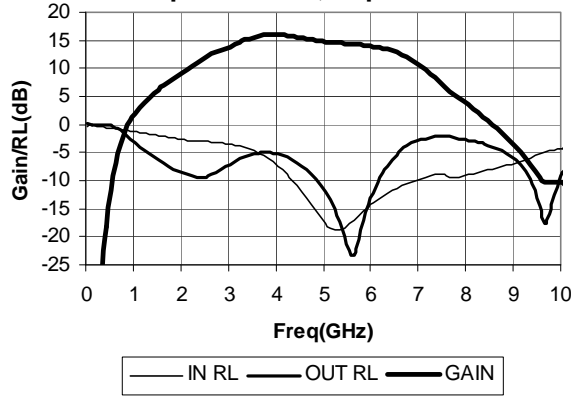

Iq vs Vsupply (Vcc)

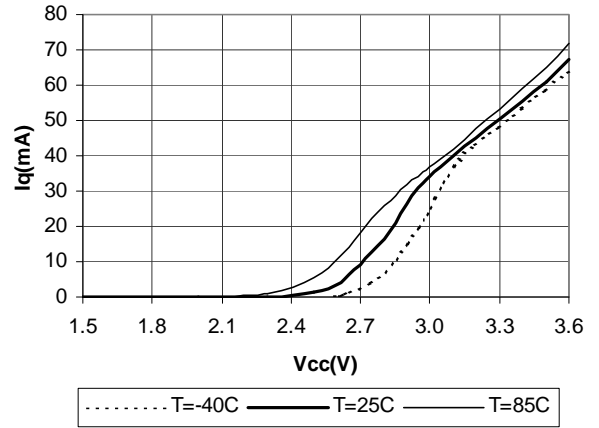

Gain vs Freq vs Temp at Vs=3.3V

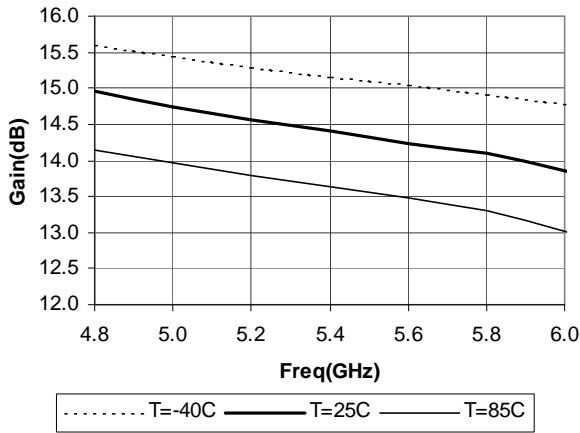

Gain vs Freq vs Vcc at T=25C

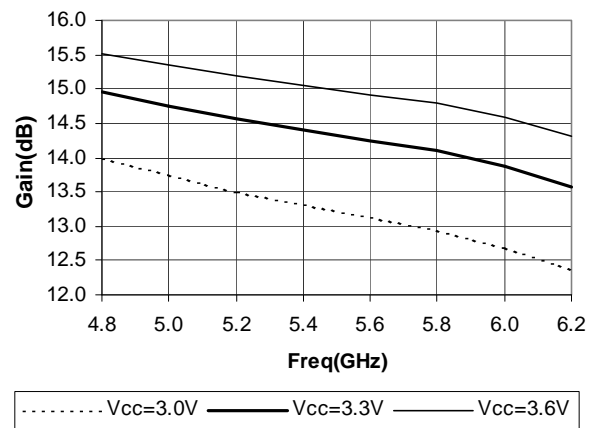

OIP3 vs Freq vs Temp at Vs=3.3V, Pout=-7.5dBm/tone

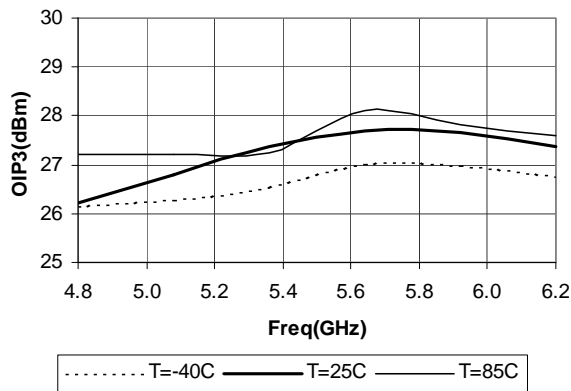

Noise Figure vs Freq at Vs=3.3V

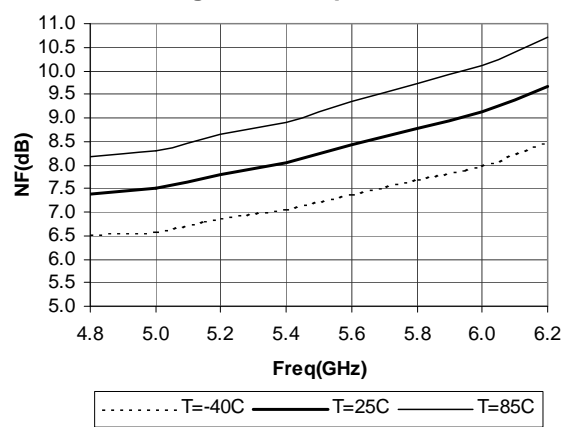

4.9GHz to 5.9GHz 802.11a Error Vector Magnitude Data (source EVM=0.7%)

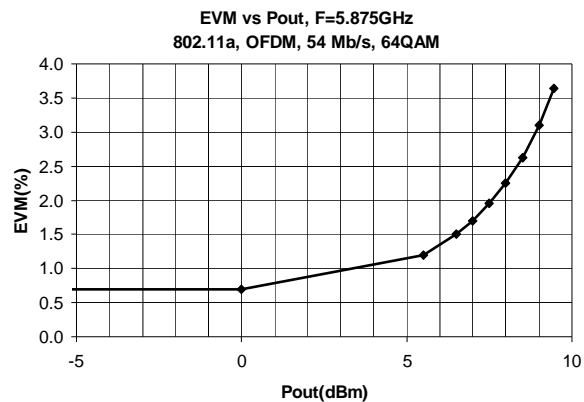
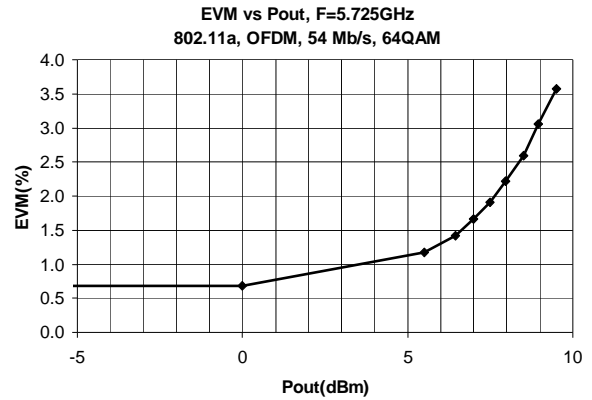
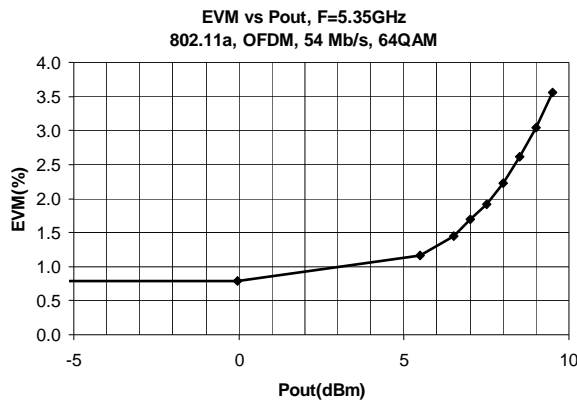
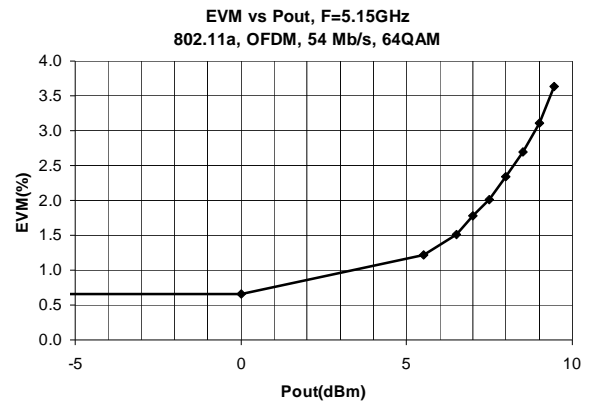
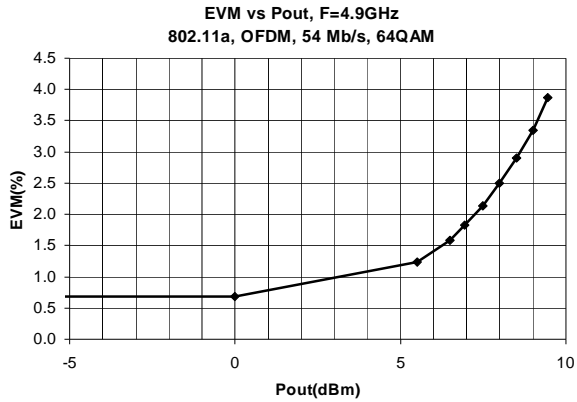

Pin	Function	Description
1	RF IN / VPC	RF input pin and power up down control. Supply VPC = 3.3V thru a 4.7 Kohm resistor to this pin. For more gain (~0.3dB), a 5.6nH inductor can also be used in place of the resistor. If an inductor is used, move the 4.7k resistor towards the DC supply, but still in series with pin 1. A minimum 1k series resistance is required on thispin from the DC supply. VPC less than 2V shuts off the amplifier.
2,5,6	GROUND	Put GND vias as close as possible to these pins. It is recommended to use the via pattern in out eval board layout and recommended land pattern
3	VCC	This provides V _{CC} to the active bias circuit and supplies the V _{CC1} collector voltage of the first stage. This pin needs to be bypassed with capacitors as close as possible to the pin. Two 0402 100pF capacitors are recom-mended in parallel to lower the inductance to GND thru the caps.
4	RF OUT	Rf output for the amplifier and V _{CC2} for the second stage.

5.1GHz to 5.9GHz Evaluation Board Schematic for 3.3V

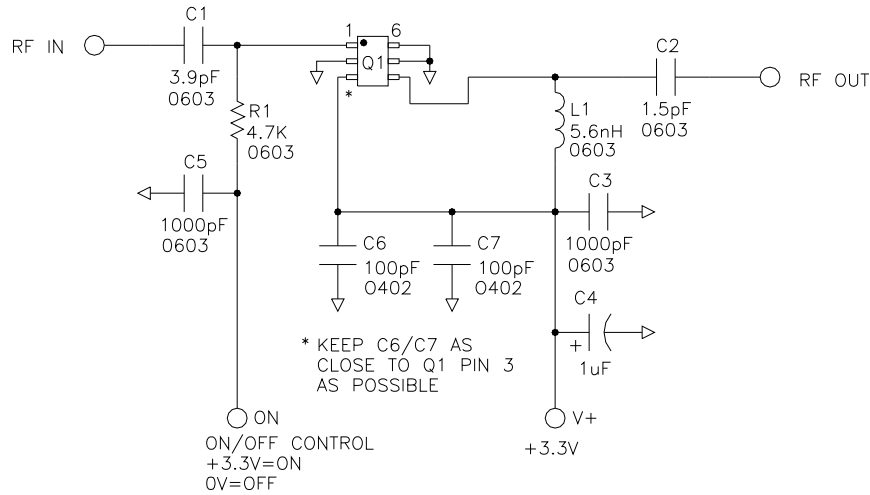

5.1GHz to 5.9GHz Evaluation Board

Board Material GETEK, 21mil thick, Dk=4.2, 2oz. copper.

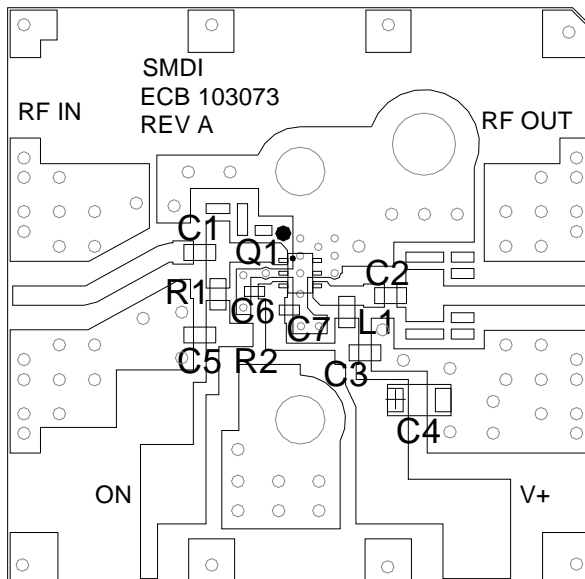

DESG	DESCRIPTION
Q1	STA-5063
R1	4.7K OHM, 0603
C1	3.9pF CAP, 0603
C2	1.5pF CAP, 0603
C3	1000pF CAP, 0603
C4	1uF 16V TANTALUM CAP
C5	1000pF CAP, 0603
C6	100pF CAP, 0402
C7	100pF CAP, 0402
L1	5.6nH INDUCTOR, 0603

3.3GHz to 3.8GHz Evaluation Board Data ($V_{CC} = V_{BIAS} = 3.3V$, $I_q = 52mA$)

3GHz Tune Input Return Loss +25c

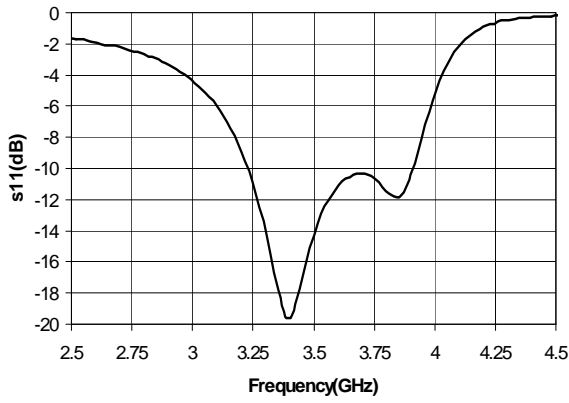

3GHz Tune Gain +25c

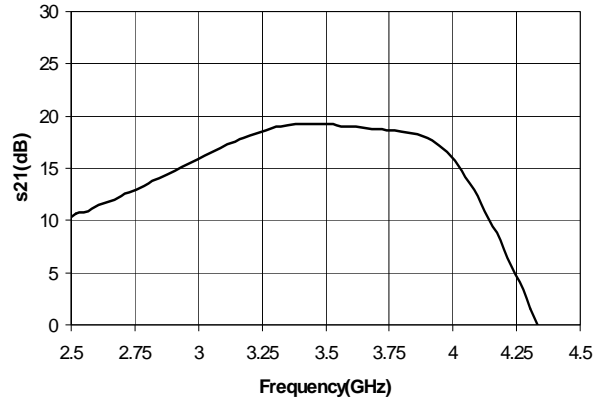

3GHz Tune Output Return Loss +25c

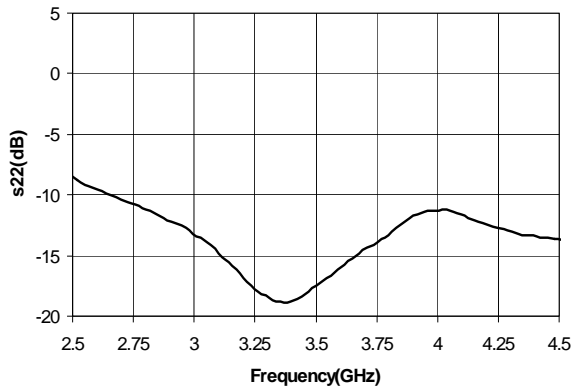

3GHz Tune IP3 & P1dB

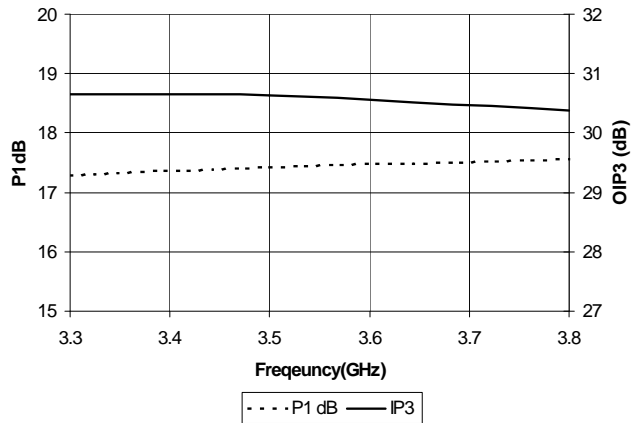

3.3GHz to 3.8GHz Evaluation Board Schematic for 3.3V

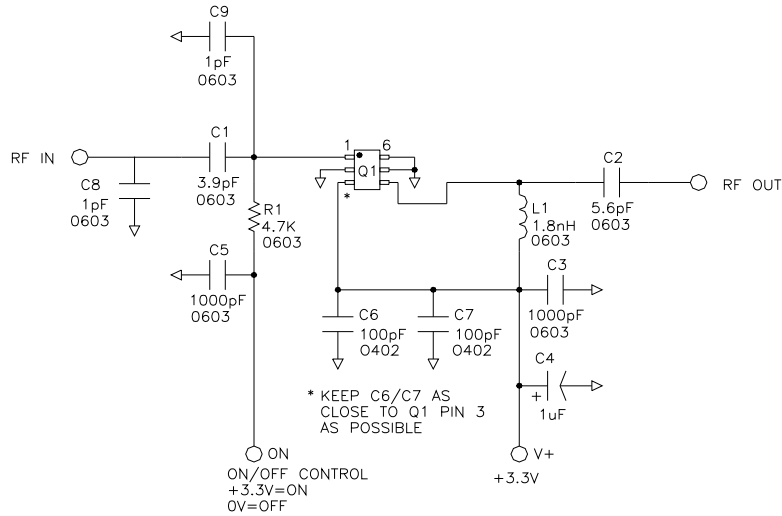

3.3GHz to 3.8GHz Evaluation Board

Board Material GETEK, 21mil thick, Dk=4.2, 2oz. copper.

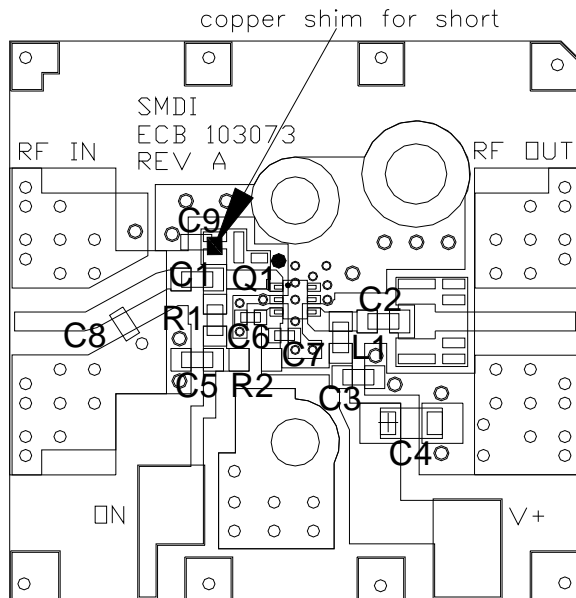

DESG	DESCRIPTION
Q1	STA-5063
R1	4.7K OHM, 0603
R2	NOT INSTALLED
C1	3.9PF, 0603
C2	5.6PF, 0603
C3	1000PF, 0603
C4	1UF, 16V
C5	1000PF, 0603
C6	100PF, 0402
C7	100PF, 0402
C8,C9	1.0pF, 0603
L1	1.8nH INDUCTOR, 0603

Package Outline Drawing

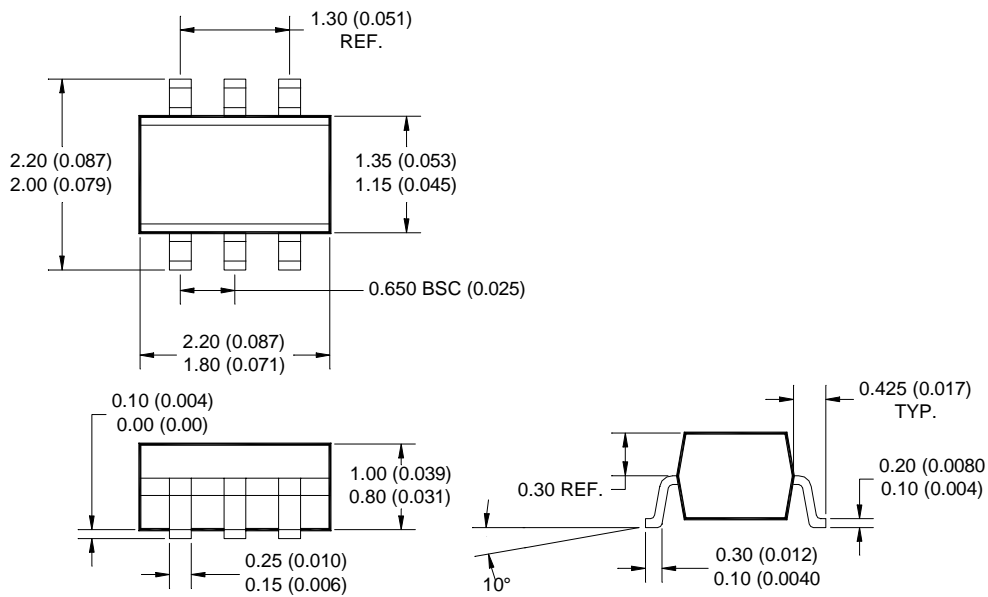

Recommended Land Pattern

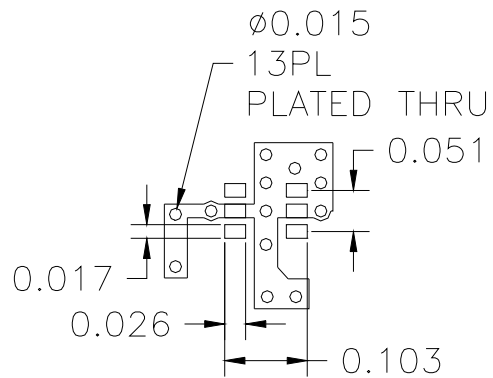

DIMENSIONS IN INCHES

Part Identification Marking

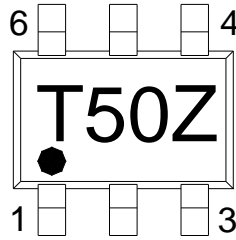

Alternate Marking with Trace Code Only

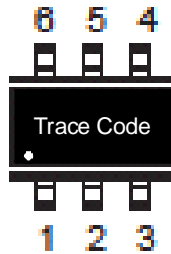

Ordering Information

Ordering Code	Description
STA5063ZSQ	Standard 25 piece bag
STA5063ZSR	Standard 100 piece bag
STA5063Z	Standard 3000 piece reel
STA5063ZPCK-EVB1	Evaluation Board 3.3GHz to 3.8GHz Tune
STA5063ZPCK-EVB2	Evaluation Board 4.9GHz to 5.9GHz Tune