



NVS TECHNOLOGIES AG

NV08C Series

- GPS, GLONASS, GALILEO, COMPASS, SBAS L1
- Compact BGA 9x12x2 mm design for SMT assembly
- Navigation and Time synchronization applications
- 32 GNSS tracking channels
- 200K correlators ensures small TTFF and high signal sensitivity
- Assisted GNSS option supported
- Various Dead Reckoning options
- NMEA 0183 (IEC 1162), BINR, RTCM SC 104 data protocols
- RAIM support
- 20 mW @ Low Power Time-to-Time Fix (TTTF) Mode
- Extended operating temperature -30 (-40) to +85°C



NV08C-MCM

GPS/GLONASS/GALILEO/COMPASS RECEIVER

The NV08C-MCM is an integrated satellite navigation receiver. The device's key feature is its ability to work with both global navigation satellite systems (GNSS) that have been deployed so far in the world – GPS and GLONASS. The GALILEO and COMPASS as well as SBAS systems are also fully supported.

The NV08C-MCM device was developed for use in high volume applications demanding low cost, low power consumption and uncompromised performance such as:

in-car and handheld personal navigation

asset and personal tracking

anti theft systems

surveillance and security systems

The NV08C-MCM offers high sensitivity and high performance of GNSS signal acquisition and tracking combined with low power consumption and small size. The assisted GPS/GLONASS/GALILEO and advanced power saving modes are supported.

Multiple satellites available from GNSS constellations ensure higher availability of navigation signal in urban canyons compared to any single constellation solution.

For system integrator the NV08C-MCM provides a variety of interfaces, flexible power supply options, power supply for optional active antenna. A very compact and complete GNSS receiver can be integrated on a low cost 2 or 4-layer PCB with a minimal number of external passive parts.

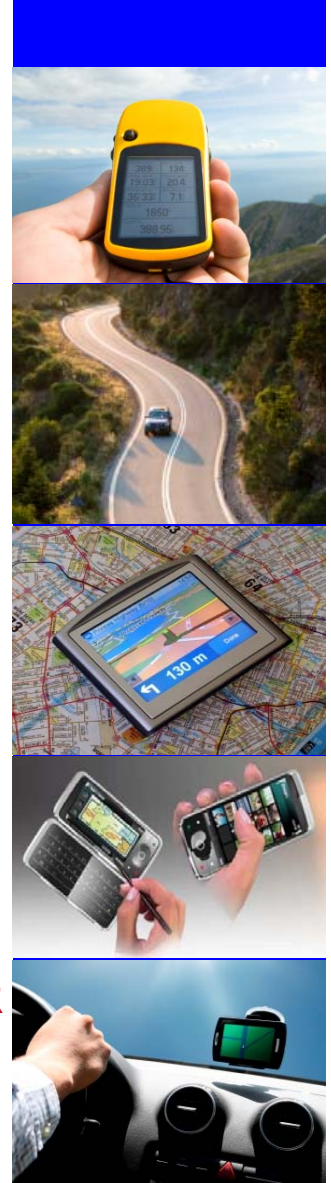

NAVIS GROUP

NVS Technologies AG
Letzastrasse 2
CH-9462 Montlingen
Switzerland
www.nvstech.ch
Phone: +41 71 760 0736
Fax: +41 71 760 0738
info@nvstech.ch

NAVIS

Dmitrovskoe sh. 157-5
127411 Moscow, Russia
www.navis.ru
Phone: +7 495 737 7674
Fax: +7 495 737 7677
navis@navis.ru

NAVIS-UKRAINE

Mazura str. 14
20708 Smila, Ukraine
Phone: +38 047 334 0246
Fax: +38 047 334 4354



Navigation Features

- **Number of channels:** 32
 - **Satellite access mode:** All-in-view
 - **GPS/GALILEO/COMPASS/SBAS:** L1 1575.42 MHz
 - **GLONASS:** L1 1597.5-1609.5 MHz
 - **Accuracy (RMS)***
 - horizontal
 - autonomous mode 2.5 m
 - differential mode 1 m
 - height 3 m
 - velocities 0.05 m/s
 - time (1PPS) ±40 ns
 - **Time to First Fix***
 - reacquisition <1 s
 - hot start <3 s
 - cold & warm start 30 s
 - **Sensitivity:**
 - tracking and reacquisition -160 dBm
 - acquisition -143 dBm
 - **Supported vehicle dynamics**
 - velocity 500 m/s
 - acceleration 5g
 - altitude 18000 m
 - **Coordinate system** WGS-84, PZ-90
SK-42, SK-95
- * typical values

RF functionality

- **LNA** Built-In (SW controlled for power saving)
- **RF structure** Two RF FE chains:
GPS/GALILEO/COMPASS/SBAS L1
GLONASS L1
- **Antenna type** Active¹ or Passive
- **Internal Clock** 26 MHz TCXO

1 - Recommended active antenna: GPS\GLONASS L1, 35MHz Bandwidth, 20dB Gain, NF < 2dB, Attenuation 35dB @ fc±70MHz

Environmental data

- **Operating temperature** -30 (-40) to +85°C
- **Maximum operating humidity** 98% @ 40°C

Data Interface

- **Data update/output rate** 1, 2, 5, 10 Hz
- **Data output rate in TTTF mode** (1-60 s)⁻¹
- **Supported protocols**
 - IEC1162 (NMEA 0183)
 - BINR (proprietary)
 - RTCM SC 104 v2.2
- **Host data interface**
 - 2x UART (1.8...3.3V CMOS-level)
 - 2x SPI
 - TWI (I²C compatible)
 - 1PPS output (CMOS level)

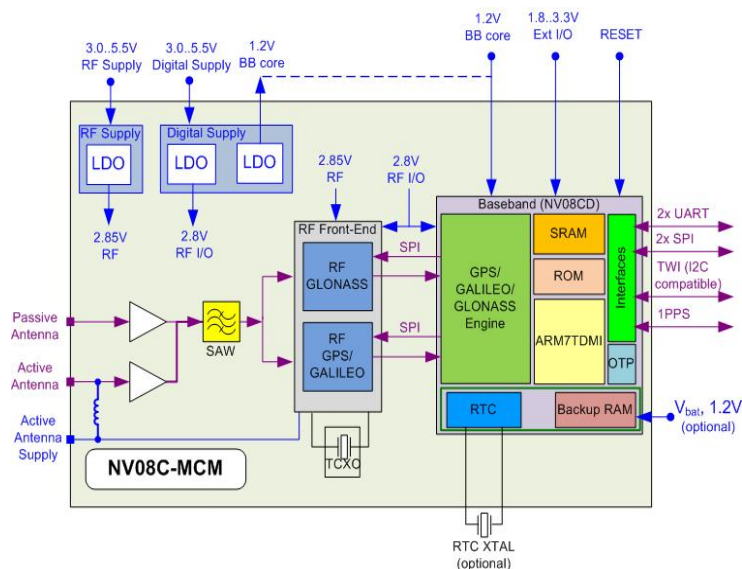

Electrical specification

- **Supply voltage configuration**
 - Single supply voltage 3.0...5.5V
 - Two supply voltages 1.2V/3.0...5.5V
- **Digital I/O voltage level (nominal)** 1.8...3.3 V
- **Backup supply** 1.2V, 4 μA
- **Power consumption (Two supply voltages)**
 - GPS only time-to-time fix mode @ 1s* 16 mW
 - GNSS time-to-time fix mode @ 1s* 20 mW
 - GPS only tracking&navigation mode* < 100 mW
 - GNSS tracking&navigation mode* < 150 mW

* average values