

PRODUCT OVERVIEW

The PEM1300 series of power extraction modules, have complete compliance with the IEEE 802.3af Power-Over-Ethernet (PoE) standard, and are designed to extract power from CAT5 Ethernet cable when sourced by a IEEE 802.3af compliant Power Sourcing Equipment (PSE).

With the increasing demand for “Green Power” IEEE has emphasized the need for power “right-sizing”. The PEM1300 series Powered Device (PD) modules provides full PoE signature and programmable power classification for granular power management.

Its high efficiency DC-DC converter provides a well regulated low noise and low ripple output with in-built overload and output short-circuit protection.

The PEM1300 series provides a quick, easy, and low cost method for Ethernet equipment manufacturers to “PoE enable” their equipment.

PRODUCT FEATURES

- Fully IEEE 802.3af compliant
- 12.95 watt output load¹
- IEEE Power class programmable (Green)
- 1500 Volt DC isolation (Input to Output)
- 3.3V, 5V, 12V DC output voltage models
- Compact package minimum PCB footprint
- Minimal external components required
- Overload and short circuit protection²
- Wide input voltage (36V to 57V DC)
- Adjustable output voltage
- RoHS 2002/95/EC compliant
- Low output ripple and noise
- Low cost



PRODUCT SELECTOR

| Part Number | Marking | Nominal Input Voltage | Output Voltage ³ | Efficiency ⁴ | Power (Maximum) ^{6,7} |
|-------------|---------|-----------------------|-----------------------------|-------------------------|--------------------------------|
| | | (Volts DC) | (Volts DC) | (%) | (Watts) |
| PEM1303 | 3 | 48 | 3.3 | 80 | 10 |
| PEM1305 | 5 | 48 | 5 | 81 | 12.95 |
| PEM1312 | 12 | 48 | 12 | 84 | 12.95 |

ABSOLUTE MAXIMUM RATINGS^{5,6}

| | |
|---------------------------------------|--|
| Supply Voltage (V _{CC}) | 0V – 57V DC |
| Storage Temperature (T _S) | -25 °C – 100 °C |
| Output Voltage (V _{OUT}) | 0V to controlled output voltage (operating or non-operating) |

INPUT CHARACTERISTICS

| Parameter | Symbol | Min. | Typ ⁴ . | Max. | Units |
|---|-------------------|----------------------------------|--------------------|------|-------|
| Input Voltage ⁷ | V _{IN} | 36 | 48 | 57 | Volts |
| Under Voltage Lockout | V _{UVLO} | 30 | | 36 | Volts |
| Input Current ^{8,10} | I _{IN} | | 350 | 400 | mA |
| Operating Temperature ⁹ | T _{OP} | -20 | 25 | 70 | °C |
| IEEE 802.3af Power Classification ¹⁰ | | Programmable Class 0, 1, 2, or 3 | | | |

DC OUTPUT CHARACTERISTICS

| Parameter | Symbol | Min. | Typ ⁴ . | Max. | Units |
|--|-------------------|------|--------------------|------|--------|
| Line Regulation ⁸ | V _{LNRG} | | 0.2% | | |
| Load Regulation ⁸ | V _{LDRG} | | 0.5% | | |
| Output Ripple and Noise ^{5,8} | V _{RIP} | | 80 | | mV p-p |
| Isolation Voltage | V _{ISOL} | | | 1500 | V DC |
| Temperature Coefficient (Slope) | TC | | 100 | 300 | ppm °C |

Figure 1 - BLOCK DIAGRAM and TYPICAL CONNECTIONS

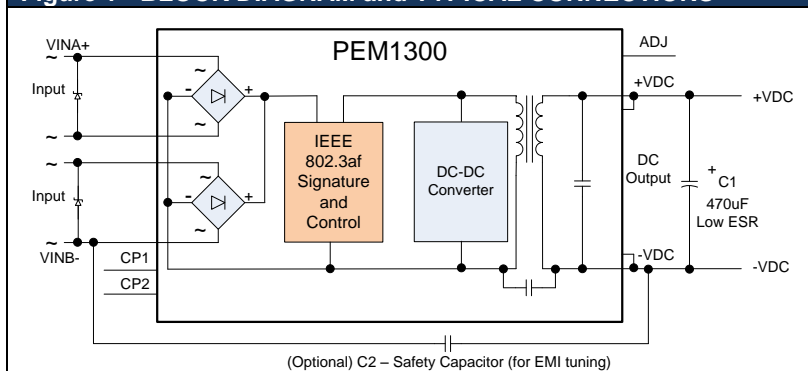

³ Output voltage typical $\pm 3\%$ at T_A of 25°C with a nominal input voltage and rated output current.

⁴ At nominal V_{in} at 67% load

⁵ All specifications typical are at T_A of 25°C with a nominal input voltage and rated output current unless otherwise noted. These are meant as a design aid only and are indicative, and not guaranteed.

⁶ Exceeding the absolute maximum ratings may cause permanent damage to the product. We do not imply functional operation under these conditions. These ratings assume free air flow.

⁷ With minimum load 100mA

⁸ Please refer to IEEE802.3af standards document. Maximum input current is dependent on power class, and input voltage. Input current (DC or RMS) at V_{PORT} = 37VDC is 350mA, at V_{PORT} = 57VDC is 230mA. Peak inrush current is 400mA for 50mS max at duty cycle of 5% max.

⁹ Please see section F.6. – Thermal profile on operating temperature

¹⁰ Please see section F.2 – Powered Device Signature and Class programming for more details

¹ In 5V and 12V model

² If maximum power is exceeded, the PEM1300 will operate in over current mode and will auto recover when the over load condition is removed.

FUNCTIONAL DESCRIPTION

F.1. Inputs

The PEM1300 is compatible with all IEEE 802.3af compliant Power Sourcing Equipment (PSE) and supports the different power injection options of Data/Signal pair (Mode A) or Spare Pair (Mode B). See Figure 2 – Typical System Configuration. As per IEEE 802.3af, it is specified that the PSE does not apply power to the both outputs at the same time i.e. 4 pair injection. (Refer to IEEE802.3af standards for more information).

The PEM1300 provides onboard input bridge rectifiers for improved system integration and minimal external components.

Figure 2 – Typical System Configuration

In Mode A – Signal Pair injection, the signal lines carry both data and power. In Mode B – Spare Pair injection, the Signal pair carries only data, and the spare pair carries power.

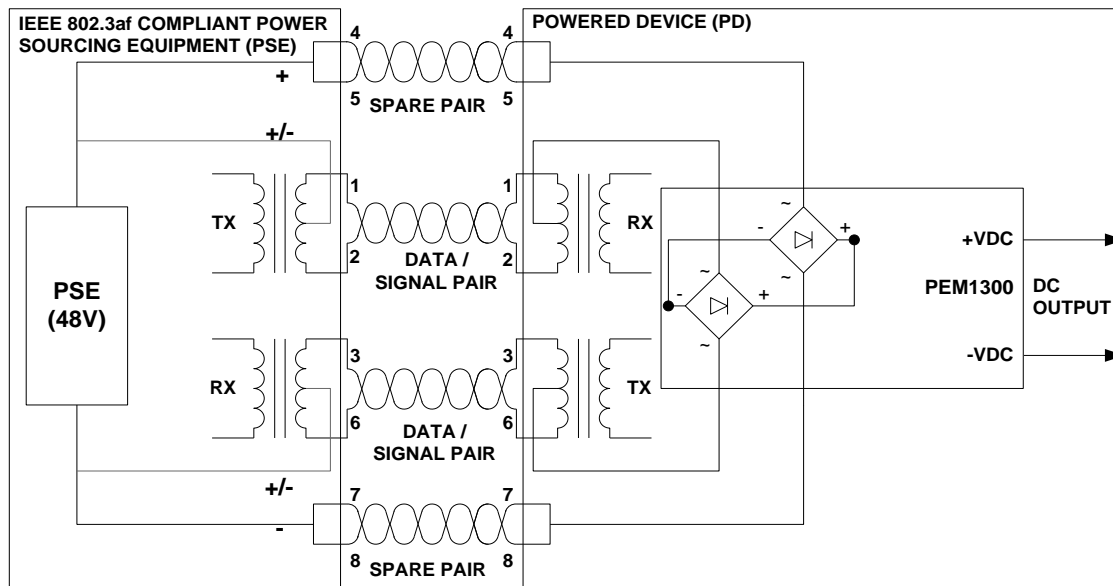

F.2. Powered Device (PD) Signature and Power Classification

When the PEM1300 is connected to a Cat 5e or greater Ethernet cable from an IEEE 802.3af compliant Power Sourcing Equipment (PSE), Endspan or Midspan, it will automatically present a Powered Device (PD) signature to the PSE, as and when requested. The PSE will then recognise that a PD is connected to that line and supply power.

With the growing emphasis on “Green Power”, in the latest standard, IEEE has stressed for PDs to implement the IEEE 802.3af **Power Classification** system to ensure correct provisioning of power from the PSE. To help in proper power level provisioning and improved power management, the IEEE 802.3af standard provides for PDs to inform the PSE their required power levels via a Class system. The classes are defined as per Table 1 below. The PEM1300 allows for programming the Class by placing a 1/16W or greater and 1% tolerance resistor detailed in Table 1.

| PoE Power Class | Required PD Power | 1/16W or greater and 1% tolerance resistor between | |
|-----------------|----------------------|--|-----------------------------|
| | | Pin 4 (VINB-) and Pin 6 (CP2) | Pin 5 (CP1) and Pin 6 (CP2) |
| 0 | 0.44W ~ 12.95W | Do not connect | Any value 10KΩ to 100 KΩ |
| 1 | 0.44W ~ 3.84W | 280kΩ | Do not connect |
| 2 | 3.84W ~ 6.49W | 143kΩ | Do not connect |
| 3 | 6.49W ~ 12.95W | 90k9kΩ | Do not connect |
| 4 | Reserved for 802.3at | Reserved | Reserved |

Important : Never connect Pin 4 (VINB-) to Pin 5 (CP1). Do not connect Pins 4 (VINB-) and 5 (CP1) and 6 (CP2) at the same time. Connect Pin 5 (CP1) only to Pin 6 (CP2) and only as per instructions in Table 1. Pin 5 and 6 may be left unconnected for default Class 0 but is not recommended.

F.3. Isolation

IEEE802.3af section 33.4.1 calls for a Powered Device (PD) to meet safety isolation requirement by meeting the electrical strength test of IEC 60950 sub clause 6.2. Infomart's® PoweredEthernet™ PEM1300 modules meet or exceed 1500V impulse test. This is also referred to as 'Hi Pot Test', 'Flash Tested', 'Withstand Voltage', 'Proof Voltage', 'Dielectric Withstand Voltage' & 'Isolation Test Voltage'.

F.4. Output Voltage Adjustment

The PEM1300 series has an OADJ pin, which allows the output voltage to be increased or decreased from its nominal value using a 1/16W power rating or greater and 1% tolerance resistor connected between the OADJ pin and either the +VDC or -VDC pin as per figures below. Only one connection i.e. between OADJ and +VDC or between OADJ and -VDC is permitted at a time. A change of more than $\pm 10\%$ from nominal is not permitted. Please [contact Infomart technical support](#) for more details or specific resistor values.

Figure 3

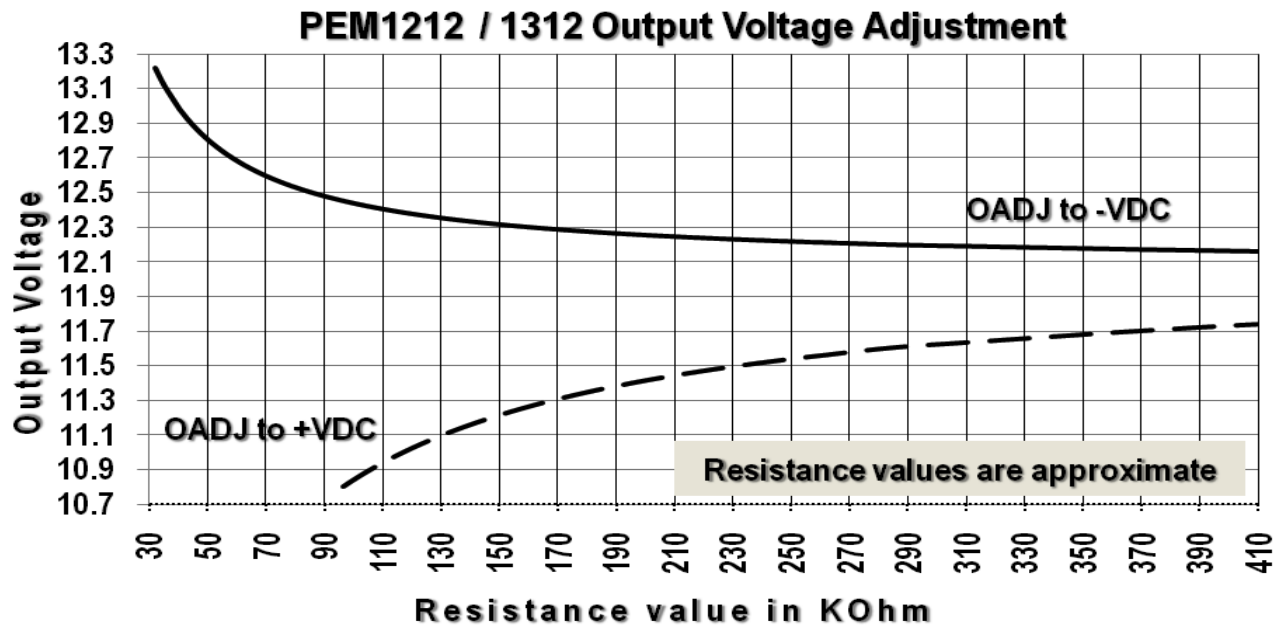

Figure 4

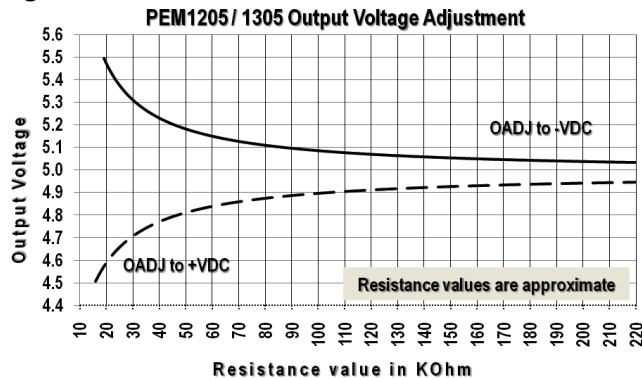
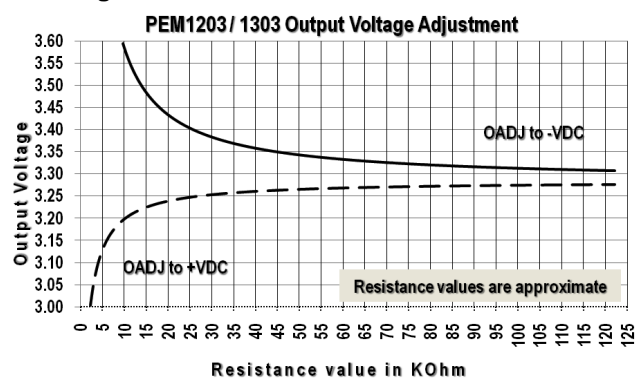

Figure 5



F.5. Pin Connections

| INPUT PINS | | OUTPUT PINS | |
|------------|---|--|--|
| 1 | VINA+ . This pin connects to Ethernet cable spare pair (for Mode B PoE injection). Not polarity sensitive. | 7 | -VDC . The ground return for the +VDC output. Max. current 3A per pin. |
| 2 | VINA- . This pin connects to Ethernet cable spare pair (for Mode B PoE injection). Not polarity sensitive. | 8 | +VDC . This pin provides the regulated output from the DC/DC converter. Max. current 3A per pin. |
| 3 | VINB+ . This pin connects to the output of the data transformer centre-tap (for Mode A PoE injection). Not polarity sensitive. | 9 | OADJ . The output voltage can be adjusted from its nominal value, by connecting an external resistor from this pin to either the +VDC pin or the -VDC pin. For more details please see section F.4. |
| 4 | VINB- . This pin connects to the output of the data transformer centre-tap (for Mode A PoE injection). Not polarity sensitive. | 10 | NC Do not connect |
| 5 | CP1 . Connect this pin only as per instructions in Table 1. | To maintain isolation integrity, always connect respective input and output poles only via X or Y safety capacitor. Maintain isolation barrier on motherboard PCB as per physical package. | |
| 6 | CP2 . Connect this pin only as per instructions in Table 1. | | |

Figure 6 – PHYSICAL PACKAGE

All dimensions in mm

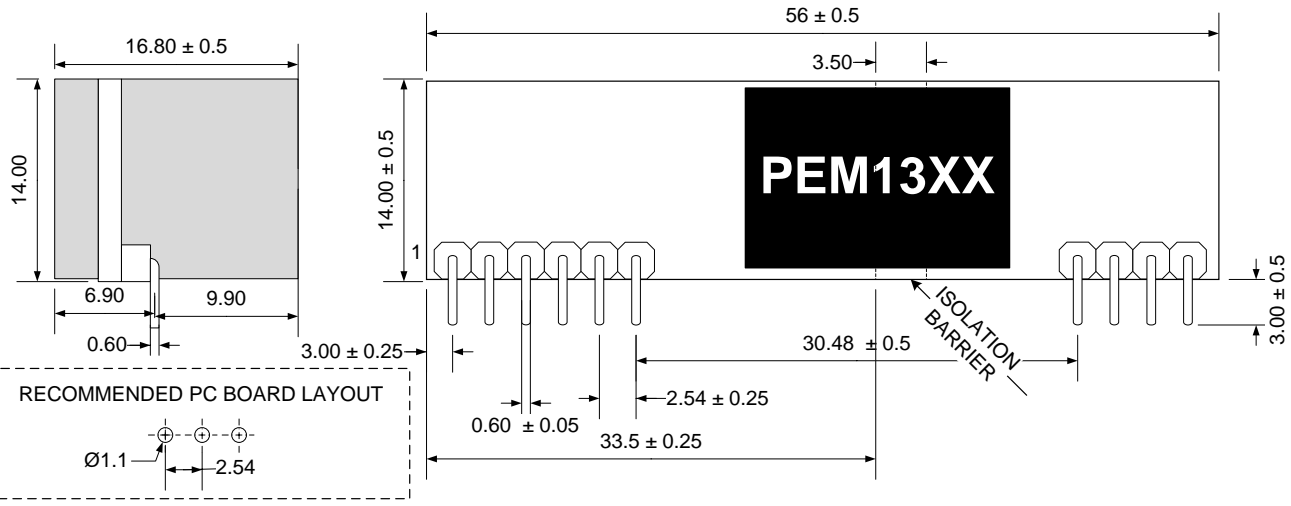

THERMAL PROFILE

F.6. Heat Generation

As with any power component, the PEM1300 modules generate heat. It is important that adequate ventilation and airflow be taken into consideration at the design stage. The quantum of heat generated by the PEM1300 will depend on the output load it is required to drive. The maximum ambient operating temperature is 70°C. Figure 7 below, shows the thermal performance of the PEM1300 with a nominal 48VDC input. The PEM1300 thermal performance can be improved by forced airflow cooling over the module and by using a heat sink (a) glued on to the output diodes using a thermal glue, or (b) by a power plane heat sink described in Figure 8 below. The two methods can be combined.

Figure 7 – Thermal Performance profile at nominal V_{in}

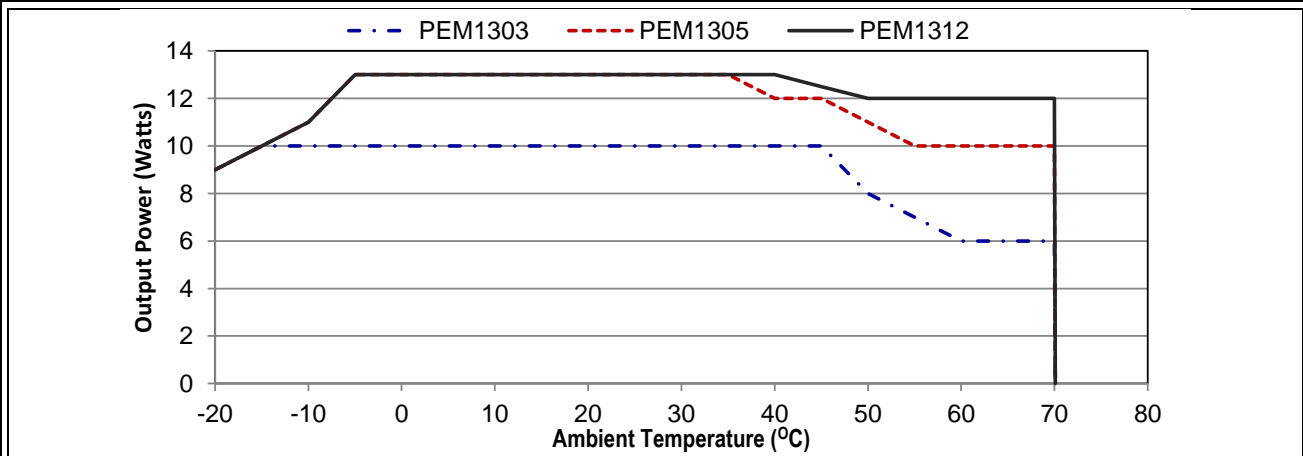
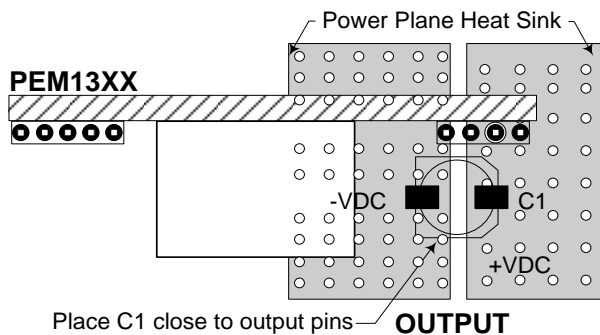

Figure 8 – Power Plane Heat Sink



A power plane heat sink on the motherboard is a relatively simple method to draw some heat away from the PEM1300 using the output pins (-VDC and +VDC) which are connected to a PCB heat sink on the motherboard. **It is important to maintain electrical isolation between OADJ pin and the +VDC and -VDC pins to ensure proper output voltages.**

These power plane heat sinks must be on the outer layers of the PCB and the PEM1300 must not be fitted into a socket.

This method can be combined with forced airflow cooling, and with a heat sink glued on to the two output diodes using a thermal glue.

APPLICATION NOTES

Power Over Ethernet (PoE) is a technology for wired Ethernet, the most widely installed local area network technology in use today. PoE allows the electrical power necessary for the operation of each end-device to be carried by data cables along with the data, rather than by separate power cords. Thus, it minimizes the number of wires used to install the network, resulting in lower cost, less downtime, easier maintenance and greater installation flexibility.

The IEEE standard governing PoE is IEEE802.3af. Compliance with this standard ensures inter-operability between devices.

The PEM1300 series modules offering a modular solution, incorporating full IEEE802.3af compatibility signature to the PSE and isolated on-board DC/DC converter. The PEM1300 series are ideal modular system blocks allowing manufacturers of Ethernet equipment to "PoE enable" their equipment with minimal effort and cost. The PEM1300 modules series offer simple and quicker product development, maximising return on investment.

PEM1300 can be powered using a user designed power supply which has adequate thermal and over-current protection. It is strongly recommended that only IEEE802.3af compliant power supply equipment be used to prevent damage to the module, which lacks output stage thermal protection .

ESD Protection: It is required that the system designer must provide ESD protection such as an SMAJ58A (uni-directional) or SMAJ58CA (bi-directional) TVS diode at the PEM1300 input(s) to prevent damage from over-voltage surges and for system EMC compliance.

APPLICATION AREAS

- Security and alarm systems
- Voice over IP phones
- Access control systems
- IP Cameras
- Displays, Net Monitors
- Public address systems
- Wireless access points
- Environmental control
- Telemetry
- Remote environmental monitoring

Figure 9 – Sample PoE System Configuration

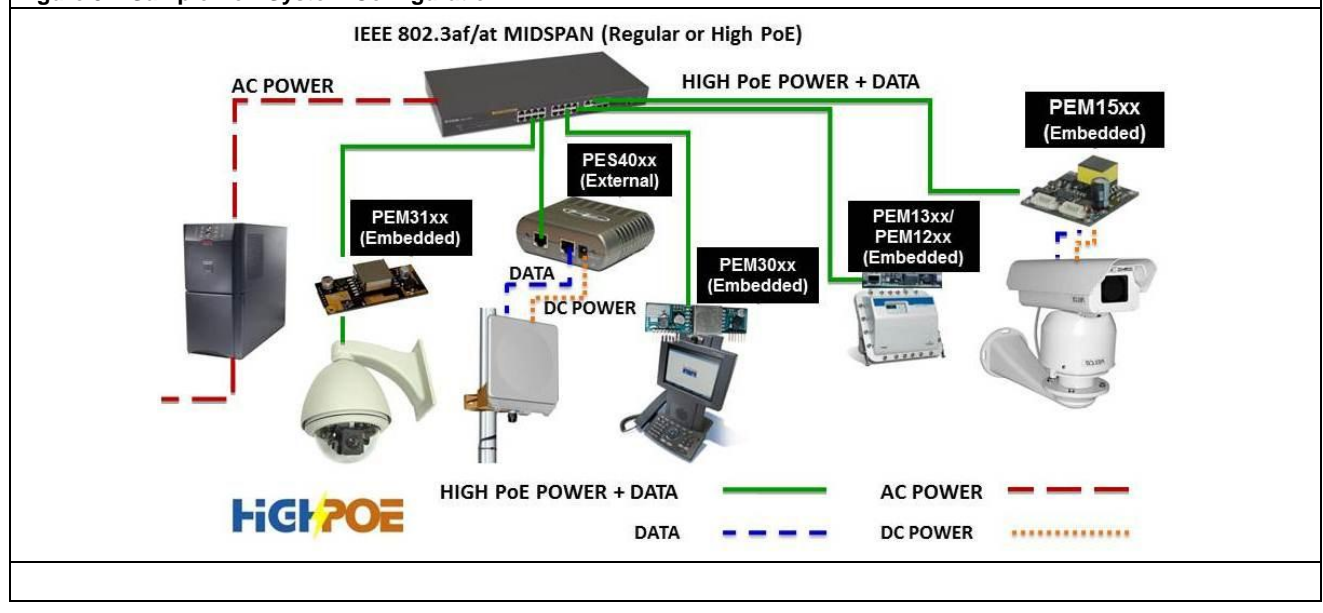

Infomart Asia Pacific Pte. Ltd.
 1, North Bridge Road #19-04
 High Street Centre
 Singapore 179094
 Tel : +65 6225-6500

Infomart India Pvt. Ltd.
 Infomart Tech Park
 99, 5th Cross, 5th Block, Koramangala
 Bangalore – 560 095, Karnataka
 India
 Tel : +91 80 4111-7200

Infomart Technologies
 Americas sales office
 5904, South Cooper St. #104-96
 Arlington, Texas, 76017, USA
 Tel : +1 (682) 234-4600

E-mail : pesales@infomartgroup.com

Infomart® reserves the right to alter or improve the specification, internal design or manufacturing process at any time, without notice. Please check with your distributor or visit our website to ensure that you have the current and complete specification for your product before use. © Infomart Asia Pacific Pte. Ltd. All rights reserved. This publication, in full or in part, may not be copied, transmitted or stored in a retrieval system, or reproduced in any way including, but not limited to, magnetic, digital, photographic, photocopy, magnetic or other recording means, without prior written permission from Infomart Asia Pacific Pte. Ltd. Infomart is a registered trademark of Infomart® (India) Pvt. Ltd. PoweredEthernet™ is a trademark of Infomart (India) Pvt. Ltd.