

HEDS-974x Series

For 180,300,360 LPI Small Optical Encoder Modules

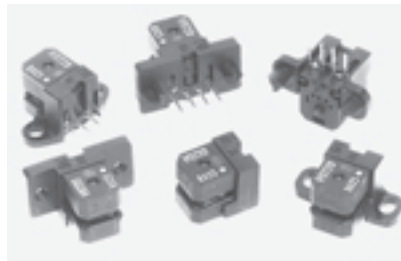

Data Sheet



Description

The HEDS-974x series is a high performance, low cost, optical incremental encoder module. When operated in conjunction with codestrip, this module detects linear position. The module consists of a lensed LED source and a detector IC enclosed in a small C-shaped plastic package. Due to a highly collimated light source and a unique photodetector array, the module is extremely tolerant to mounting misalignment.

The two-channel digital outputs and 5 V supply input are accessed through four solder-plated leads located on 2.54 mm (0.1 inch) centers.

Applications

The HEDS-974x provides sophisticated motion detection at a low cost, making close-loop control very cost-competitive! Typical applications include printers, plotters, copiers, and office automation equipment.

Note: Agilent Technologies encoders are not recommended for use in safety critical applications. Eg. ABS braking systems, power steering, life support systems and critical care medical equipment. Please contact sales representative if more clarification is needed.

Theory of Operation

The HEDS-974x is a C-shaped emitter/detector module. Coupled with a codewheel, it translates rotary motion into a two-channel digital output. Coupled with a codestrip, it translates linear motion into digital outputs.

As seen in the block diagram, the module contains a single Light Emitting Diode (LED) as its light source. The light is collimated into a parallel beam by means of a single lens located directly over the LED. Opposite the emitter is the integrated detector circuit.

This IC consists of multiple sets of photodetectors and the signal processing circuitry necessary to produce the digital waveforms.

The codestrip moves between the emitter and detector, causing the light beam to be interrupted by the pattern of spaces and bars on the codestrip. The photodiodes which detect these interruptions are arranged in a pattern that corresponds to the count density of the codestrip. These detectors are also spaced such that a light period on one pair of detectors corresponds to a dark period on the adjacent pair of detectors. The photodiode outputs are fed through the signal processing circuitry. Two comparators receive these signals and produce the final outputs for channels A and B. Due to this integrated phasing technique, the digital output of channel A is in quadrature with channel B (90 degrees out of phase).

Features

- **Small size**
- **Multiple mounting options**
- **Wide resolution range**
- **Linear options available**
- **No signal adjustment required**
- **Insensitive to radial and axial play**
- **-40°C to +85°C operating temperature**
- **High resolution version of the HEDS-970x**
- **Two-channel quadrature output**
- **TTL or 5.0 V CMOS compatible**
- **Single 5 V supply**
- **Wave solderable**
- **Integrated 2.5 K Ω pullup on outputs**

ESD WARNING: NORMAL PRECAUTIONS SHOULD BE TAKEN TO AVOID STATIC DISCHARGE.

Definitions

Count (N) = the number of bar and window pairs or Counts Per Revolution (CPR) of the codewheel, or the number of Lines Per Inch (LPI) of the codestrip.

$$1 \text{ Shaft Rotation} = 360 \text{ mechanical degrees} \\ = N \text{ cycles}$$

$$1 \text{ Cycle (c)} = 360 \text{ electrical degrees (e)} \\ = 1 \text{ bar and window pair}$$

Pulse Width (P): The number of electrical degrees that an output is high during one cycle. This value is nominally 180°e or 1/2 cycle.

Pulse Width Error (ΔP): The deviation, in electrical degrees, of the pulse width from its ideal value of 180°e.

State Width (S): The number of electrical degrees between a transition in the output of channel A and the neighboring transition in the output of channel B. There are four states per cycle, each nominally 90°e.

State Width Error (ΔS): The deviation, in electrical degrees, of each state width from its ideal value of 90°e.

Phase (ϕ): The number of electrical degrees between the center of the high state of channel A and the center of the high state of channel B.

This value is nominally 90°e for quadrature output.

Phase Error ($\Delta\phi$): The deviation of the phase from its ideal value of 90°e.

Direction of Rotation: When the codewheel rotates counter-clockwise, as viewed looking down on the module (so the marking is visible), channel A will lead channel B. If the codewheel rotates in the opposite direction, channel B will lead channel A.

Optical Radius (R_{OP}): The distance from the codewheel's center of rotation to the optical center (OC) of the encoder module.

Angular Misalignment Error (E_A): Angular misalignment of the sensor in relation to the tangential direction. This applies for both rotary and linear motion.

Mounting Position (R_M): Distance from motor shaft center of rotation to center of alignment tab receiving hole.

Absolute Maximum Ratings

Parameter	Symbol	Min.	Max.	Units	Notes
Storage Temperature	T_S	-40	85	°C	
Operating Temperature	T_A	-40	85	°C	
Supply Voltage	V_{CC}	-0.5	7	V	
Output Voltage	V_O	-0.5	V_{CC}	V	
Output Current per Channel	I_O	-1.0	5	mA	
Soldering Temperature			260	°C	$t \leq 5 \text{ sec.}$

Recommended Operating Conditions

Parameter	Symbol	Min.	Typ.	Max.	Units	Notes
Temperature	T	-40		85	°C	
Supply Voltage	V _{CC}	4.5	5.0	5.5	V	Ripple < 100 mVp-p. Recommended one bypass capacitor (1 µF) between V _{CC} and GND less than 15 cm from the encoder.
Load Capacitance	C _L			100	pF	
Pullup Resistor	R _L		none			Recommended no pullup. Device has integrated 2.5 kΩ on outputs.
Count Frequency				40	kHz	(Velocity (rpm) x N) / 60
Angular Misalignment	E _A	-2.0	0	+2.0	deg.	Mounting considerations.

Electrical Characteristics over Recommended Operating Range, Typical at T_A = 25°C

Parameter	Symbol	Min.	Typ.	Max.	Units	Notes
Supply Current	I _{CC}	12	21	40	mA	
High Level Output Voltage	V _{OH}	2.4			V	I _{OH} = -200 µA
Low Level Output Voltage	V _{OL}			0.4	V	I _{OL} = 3.2 mA
Rise Time	t _r		70		ns	C _L = 25 pF
Fall Time	t _f		45		ns	R _L = (NO pullup)

Encoding Characteristics

Encoding Characteristics over Recommended Operating Range and Recommended Mounting Tolerances. These characteristics do not include codewheel/codestrip contribution. The Typical Values are averages over the full rotation of the codewheel.

Parameter	Symbol	Typical	Maximum	Units
Pulse Width Error	ΔP	5	40	°e
Logic State Width Error	ΔS	3	40	°e
Phase Error	Δφ	2	15	°e

Recommended Codewheel and Codestrip Characteristics

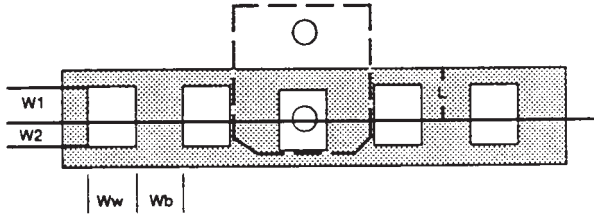

Parameter	Symbol	Min.	Max.	Units	Notes
Window/Bar Ratio	Ww/Wb	0.7	1.4		
Center of Post to Inside Edge of Window	W1	1.04 (0.041)		mm (inch)	
Center of Post to Outside Edge of Window	W2	0.76 (0.030)		mm (inch)	
Center of Post to Inside Edge of Codestrip	L		3.60 (0.142)	mm (inch)	

Mounting Considerations

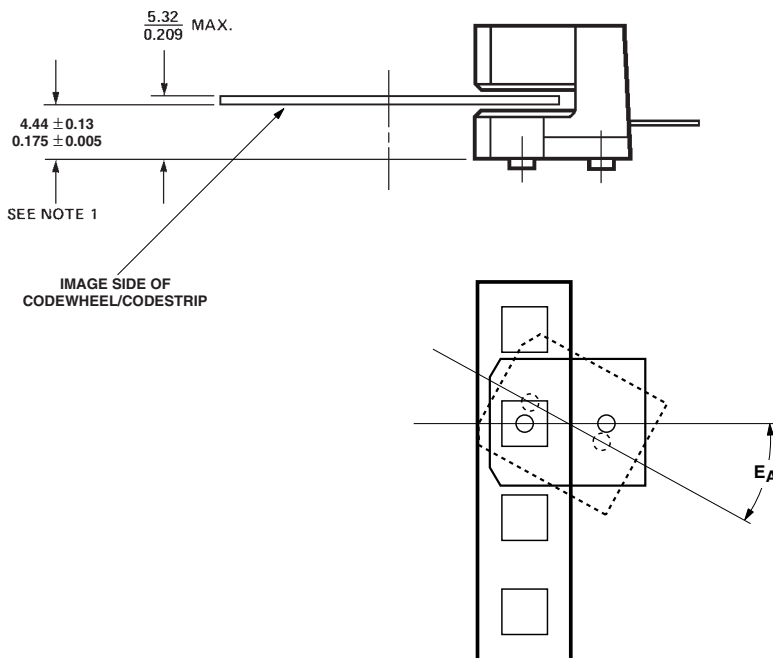

For linear motion, angular misalignment, E_A , must be $\leq \pm 2$ degrees to achieve Encoding Characteristics.

All dimensions for mounting the module and codestrip should be measured with respect to the two mounting posts, shown above.

Recommended Screw Size: M2.5 x 0.45 or 2-56

Recommended Wave Solder Conditions

Flux – RMA Water Soluble (per MIL-F-14256D)

Process Parameters

1. Flux
2. Pre-heat 60 seconds total
Nominal preheat temp: 90°C
Min: 85°C Max: 110°C
3. Solder Pot Zone
Nominal dip in time:
2.5 - 4.5 seconds
Min: 2.5 seconds
Max: 5 seconds
PCB top side: 140 -160°C
PCB bottom side: 240 - 260°C
4. Wave Solder 255°C,
1.2 meters/minute line speed
5. Hot Water Wash
1st: 30°C 45 seconds
2nd: 70°C 90 seconds
6. Rinse
1st: 23°C 45 seconds
2nd: 23°C 45 seconds
7. Dry
1st: 80°C 105 seconds
2nd: 95°C 105 seconds

Ordering Information

HEDS-974 Option

Lead Bend 0 – Straight Leads 1 – Bend Leads	Resolution Options Q – 180 LPI, linear 2 – 300 LPI, linear 1 – 360 LPI, linear	Mounting Options 50 – Standard
----------------------------------------------------------	------------------------------------------------------------------------------------------------	------------------------------------------

		50	51	52	53	54	55
HEDS-9740	Q	*					
	2	*					
	1	*					
HEDS-9741	Q						
	2	*					
	1						

Package Dimensions

Mounting Option #50

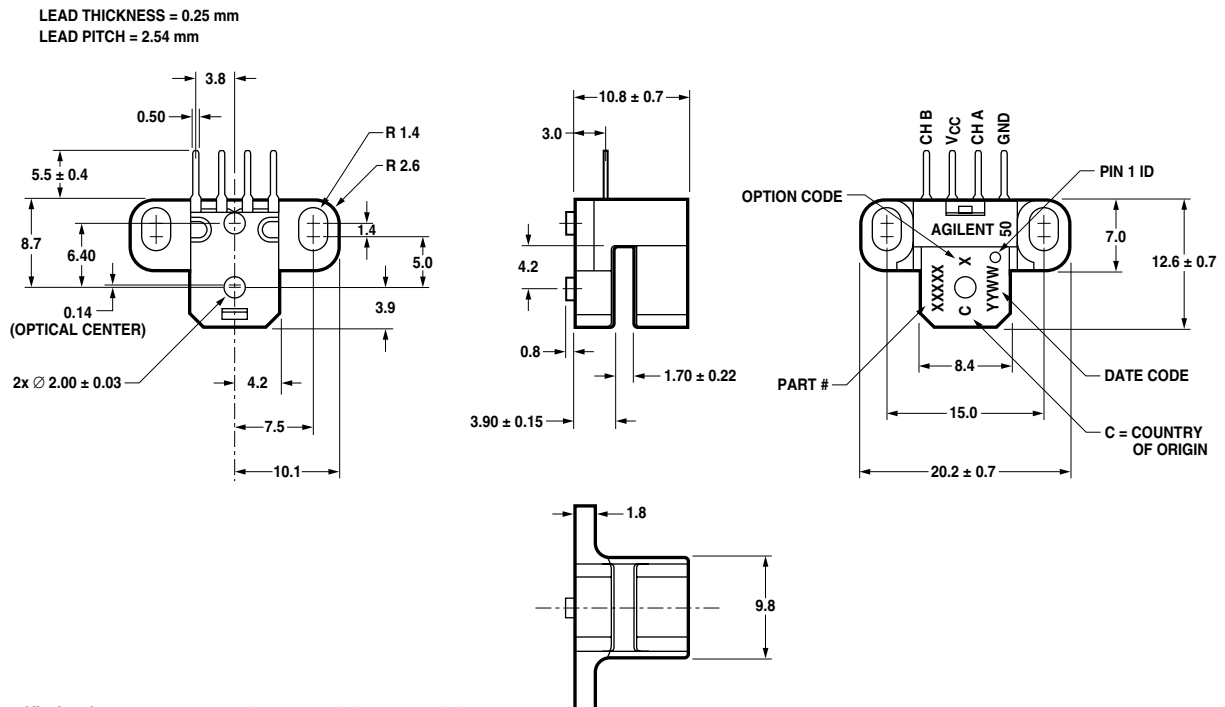

Note:
If not specified, tolerances are xx. ± 0.7, xx.x ± 0.3, xx.xx ± 0.07 mm.

For product information and a complete list of distributors, please go to our website: www.avagotech.com

Avago, Avago Technologies, and the A logo are trademarks of Avago Technologies Limited in the United States and other countries.
Data subject to change. Copyright © 2008 Avago Technologies Limited. All rights reserved. Obsoletes 5988-6067
5988-8042EN January 23, 2008

