

Description

The Redington Model 34 LCD Totalizer/Preset Counter provides a large display, with 0.28" [7mm] high characters, in industry size housings. The Model 34 counts and displays the number of pulses that appear at its input terminal at a rate of 40 pulses per second (Hz). The input interface handles AC or DC inputs. The Totalizers are available in 7 different housings. All models are totally sealed and are capable of submersion in 6' [2 meters] of water. A wide operating voltage, 10-300VDC and 20-300VAC, makes the model 34 versatile for all indoor and outdoor applications. All models are NEMA 4/4X, 12, & IP66 rated when used with the optional gasket and have a polarized lens which assures high visibility in an outdoor environment.

Maintenance Meters are offered with a maximum of 3 preset "Redi-Alert's" icons to alert users when service intervals are due or other periodic timed events are due. Models are available with front panel field or factory programmable alerts. Not only does the display flash to get attention, but it displays a choice of 7 different .08" [2mm] maintenance icons. Models are available with an Open Drain MOSFET output for the actuation of external alarms or indicator lamps. Users can program or specify the count/service interval and flash duration for each Redi-Alert. Flash duration is the amount of time in hours that the specific icon flashes before and after the specified total count. If a front panel manual reset of the Redi-Alert is required, the front panel models with switches must be specified.

Features

- Totally sealed from moisture and dirt
- AC or DC voltage input in the same unit
- Compact depth
- Programmable output thresholds
- Preset count value
- Up to 3 Redi-Alerts/7 icons
- Fits in existing panel openings
- Always on display
- A choice of 7 housings
- A choice of reset modes
- Front panel programmable
- Preset Counter with output
- 15+ Year Battery Life

Specifications

Display:	LCD with large 0.28" [7mm] high figures black on light background	Environmental:	Temperature: (Storage and Operating) -40 to +185°F [-40 to +85°C] Humidity: 95% RH per SAE J1378 Vibration: 20g @ 10 to 80 Hz per SAE J1378 Shock: 44 to 55g's per SAE J1378 Dielectric: 1000VAC 50/60 Hz for 1 minute Compliance: Compliant to the European WEEE and RoHS Directives
Annunciators:	LCD 0.08" [2mm]	Sealing:	Totally sealed
Reset:	Remote, manual and non-reset	EMC Compliance:	EN61326:1997 with A1:1998 and A2:2001 for industrial environments
Accuracy:	100% [provided signal meets stated parameters]	Enclosure:	Totally sealed from moisture and dirt, NEMA 4/4X, 12, & IP66 compliant from the front when properly mounted using the optional gasket. (Not applicable to Snap-In Model)
Displays:	8 digits (99999999)	Approvals:	UL and cUL Recognized (file # ELIY2.E36690), CE, SAE, NEMA 4/4X/IP66 compliant
Maximum pulse rate:	40 pulses per second (Hz)	Weight:	1oz [28g]
Inputs:	10-300VDC and 20-300VAC - 50/60Hz VIH 20VAC or 10VDC minimum VIL 3VAC or 3VDC maximum		
Power:	Self powered - battery life 15+ years		
Terminations:	Standard 0.250" [6.4mm] spades		
Output:	Format: Open-Drain MOSFET with Source connected to Common (see note 3) Maximum Withstanding voltage: 30VDC, reference to Common Maximum Load current: 0.1Amp		



Functions

Preset Counter: The preset function is centered on the output signal. When the count reaches the preset value, the output signal is turned "on". The Preset function is count "up". In addition to the preset function, models are also available with 3 Redi-Alert set points. Upon reaching the preset value the preset can be automatically reset, or it can await an external reset.

Front Panel Switch Functions: Front panel switches can be used for reset, display selection and programming. The two front switches are used as follows:

SEL: During programming this switch is used to select options and to move horizontally in the programming chart.

RST: This is the reset switch during normal operation. During programming this switch is used to select options and to move vertically in the programming chart.

Available Icons



SERVICE



OIL



AIR FILTER



MUFFLER



CHANGE



OIL FILTER



LAMP

Dimensions

Rectangular Flush Mount

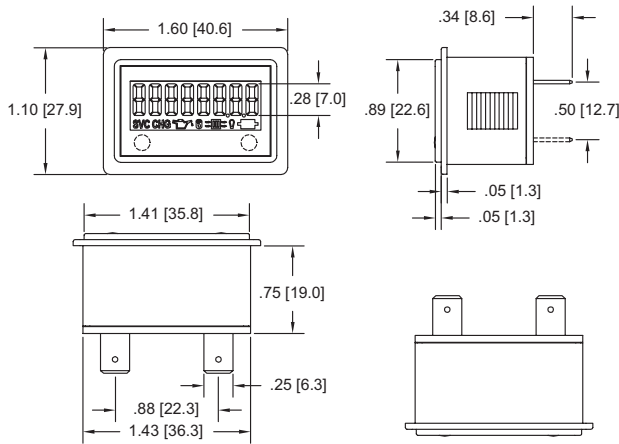

Panel Cutout: 1.45" [36.8mm] x 0.95" [24.1mm]
Maximum Panel Thickness: 0.375" [9.5mm]

2-Hole Mount

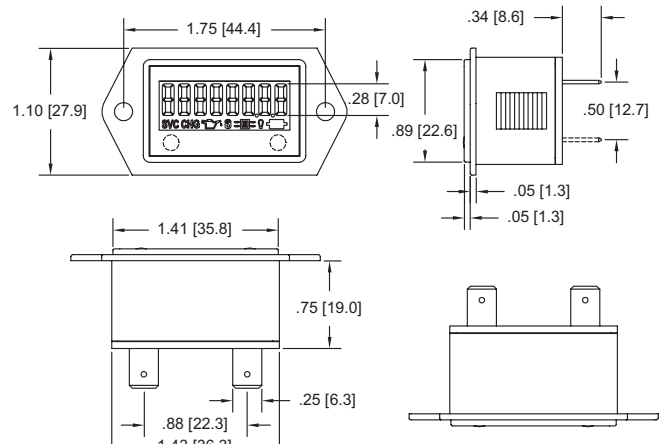

Panel Cutout: 1.45" [36.8mm] x 0.95" [24.1mm]

2-Hole No-Hole Mount

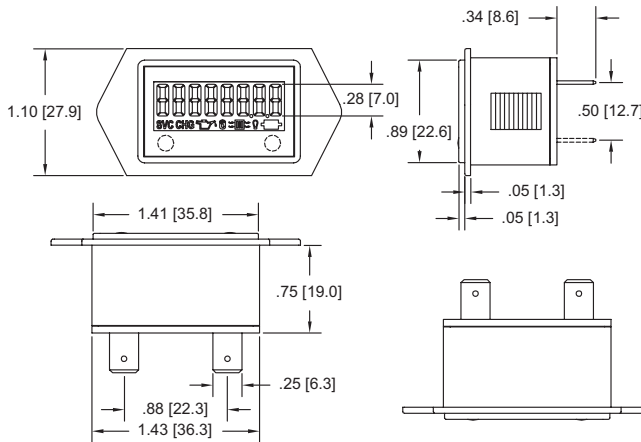

Panel Cutout: 1.45" [36.8mm] x 0.95" [24.1mm]
Maximum Panel Thickness: 0.375" [9.5mm]

Round Flush Mount

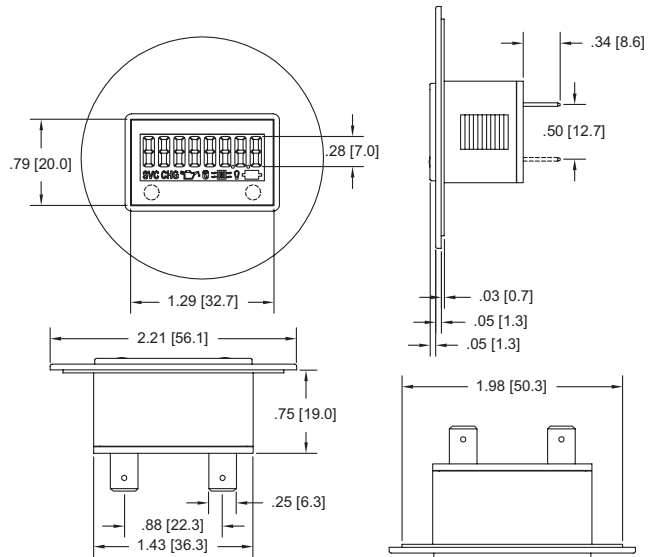

Panel Cutout: 1.45" [36.8mm] x 0.95" [24.1mm]
Maximum Panel Thickness: 0.375" [9.5mm]



3-Hole Mount

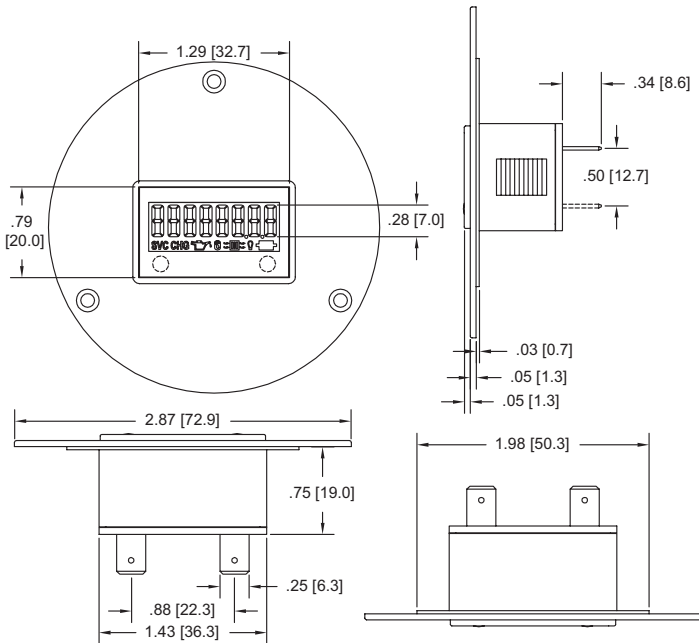

Panel Cutout: 1.45" [36.8mm] x 0.95" [24.1mm]

Snap-In Mount

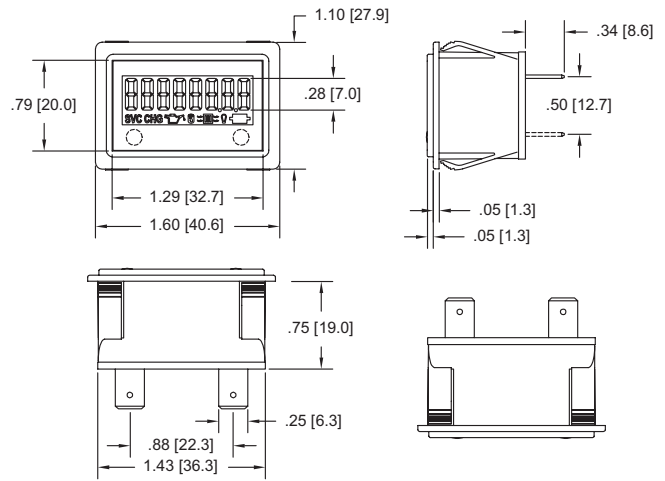

Panel Cutout: 1.46" [37mm] x 0.95" [24.1mm]
 Minimum Panel Thickness: 0.04" [1.0mm]
 Maximum Panel Thickness: 0.125" [3.18mm]

Square Flush Mount

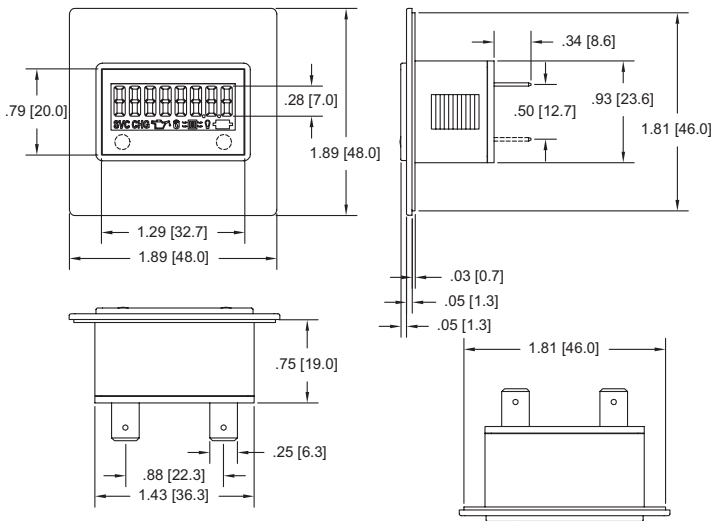

Panel Cutout: 1.45" [36.8mm] x 0.95" [24.1mm]
 Maximum Panel Thickness: 0.375" [9.5mm]

Notes

1. When interfacing the Model 34 with a Solid State Relay or AC Sensor, the leakage current needs to be considered. Contact the factory or see the application note at www.redingtoncounters.com
2. Exceeding the Absolute Voltage Range and the Absolute Maximum Limits may result in damage to the unit.
3. The open-drain MOSFET acts like an open-collector NPN transistor. Care should be taken since there is no current limiting protection in the unit.

Applications

