

# Stepper motor drivers

## ■ Closed loop positioning controller with encoder input, SMC135



When the SMC135 is delivered, it is preconfigured to clock direction mode. Connection to the PC is not necessary. The phase current can be set in 10% steps on a DIP switch (10% = 400mA, max. 150% = 6A). The inputs for the clock, direction and enable signal are already preconfigured on the X4 connector. The step mode can only be changed via software. Full step is preset. Sinusoidal commutation, however, means extremely smooth running and very good performance of the stepper motor is already achieved in the full step.

### Technical data

<b>Operating voltage:</b>	DC 24 - 48 V
<b>Phase current:</b>	max. 6 A
<b>Interface:</b>	TTL-RS232 (3.3 V)
<b>Operating mode:</b>	Position, speed, flag position, clock direction, analog, joystick
<b>Step resolution:</b>	1/1, 1/2, 1/4, 1/5, 1/8, 1/10, 1/32, 1/64
<b>Step frequency:</b>	16 kHz with a full step, corresponding multiples with a microstep (e.g. up to 1 MHz with 1/64)
<b>Inputs:</b>	6 digital inputs (TTL), 1 analog input +10/-10 V
<b>Outputs:</b>	3 digital outputs (TTL)
<b>Position monitoring:</b>	Yes, depending on the encoder
<b>Current reduction:</b>	Adjustable 0 - 100%
<b>Protection circuit:</b>	Overvoltage, undervoltage and heatsink temperature > 80 °C
<b>Temperature range:</b>	0 to +40 °C

### Outline drawing (mm)

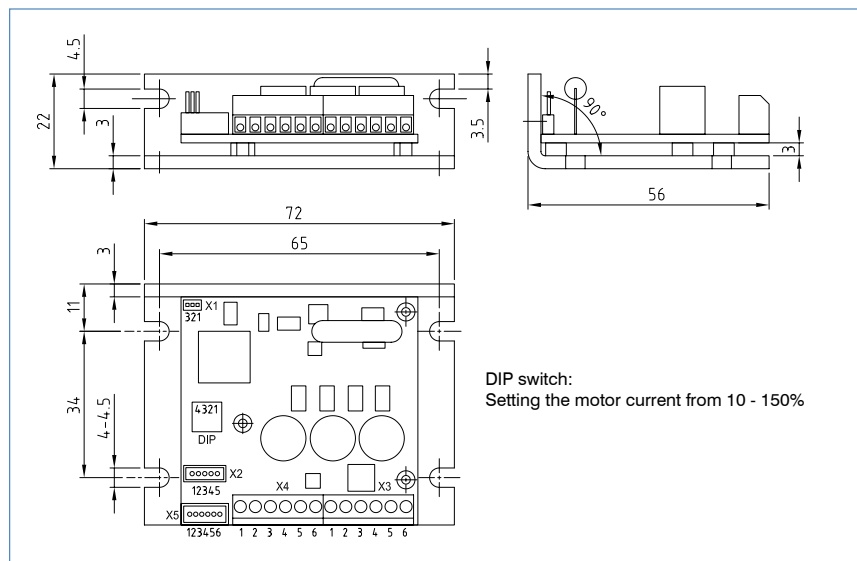

### Communication (X1)

Pin	Function*
1	GND
2	TX
3	RX

### Encoder (X2) JST-ZHR 5

Pin	Function*
1	GND
2	CH-B
3	INDEX
4	CH-A
5	+5 V

### Motor and supply (X3)

Pin	Function*
1	Motor coil A
2	Motor coil A\
3	Motor coil B
4	Motor coil B\
5	UB 24-48 V
6	GND

### Inputs/Outputs (X4)

Pin	Function*	Function on delivery
1	Output 1	
2	Input 6	CLOCK
3	Input 5	DIRECTION
4	Input 4	ENABLE
5	Analog in 1	
6	GND	

### Inputs/Outputs (X5) JST-ZHR 6

Pin	Function*
1	GND
2	Output 3
3	Output 2
4	Input 3
5	Input 2
6	Input 1

\* from the perspective of the connected controller

### Input circuits

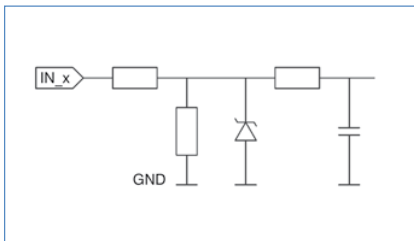

### Order number

**SMC135**