

Barrier Strip Filtered Terminal Blocks

The barrier strip filtered terminal block is designed provide excellent EMI/RFI filtering of AC and DC power lines and control lines. This terminal block is available in various sizes, with terminal for soldering or spade lugs. Application examples include filtering power supplies in telecommunications equipment, metering, industrial controls, instrumentation and EDP equipment.

Features

- UL recognized and CSA approved for DC voltages
- E133076, UL 1059
- LR92537, CSA STD 22.2 N°158-1987 and ECN584B
- Filter element provides high insertion loss for EMI/RFI filtering of AC and DC power and control lines
- Rugged construction provides protection to filtering element; especially useful for repeated changes in wiring or field connections
- 2 to 6 terminals available (combine if larger number of terminals needed)
- Cost-effective solution for industrial interconnection EMI filtering problems
- Termination options available: straight lead, male or female disconnects, pigtail (12 AWG = 0.081" (2.05mm); 22 AWG = 0.025" (0.64mm))
- Available in RoHS compliant versions

Ordering Information

Example: **52-160-006-A AOO**

The part number shown represents a barrier strip terminal block with six terminals and rated for 20 Amps. Male disconnects (.250") are the method of termination.

52	*	160	-	006	-	A
		Barrier Strip Terminal Block		Number of Terminals		Current Rating
		160 - Front panel mount		002 - 2 terminals through		A - 20 Amps
		188 - Rear panel mount		006 - 6 terminals		

For instructions on soldering to filter terminals, please refer to page 107 in filter plate section.

* Replace "--" with "F" for RoHS complaint version



Specifications

ELECTRICAL

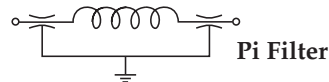

Operating temperature: -55° C to 105° C
Working voltage: 100VDC
Capacitance: 2,500 pF to 5,200 pF
Dielectric withstanding voltage: 1700VDC
Current rating: 20A
D.C. resistance: .01 ohms max.

Typical Insertion Loss — dB: In 50 Ohm Circuit	
30 MHz.....22	300 MHz.....70
50 MHz.....32	500 MHz.....75
100 MHz.....48	1000 MHz.....75

MECHANICAL

Center spacing: .438" (11.1 mm)
Wire size: AWG #12 max for 20A
Screw size: 20A - #6-32, zinc-plated phillslot screws
Molded material: Black, UL rated 94VO thermoplastic
Tightening torque: 9 in.-lbs. max.
Terminal: Brass, tin-plated

AOO

Special Terminations Code

Note: Leave blank if ordering standard product.

Male quick disconnects directly on terminal block.

AO1187 (4.8)

AOO250 (6.4)

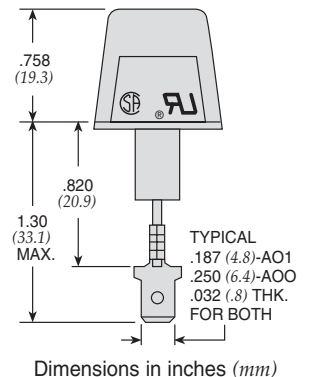

For custom designs see page 127 and consult with factory.

Barrier Strip Filtered Terminal Blocks

Front panel mount

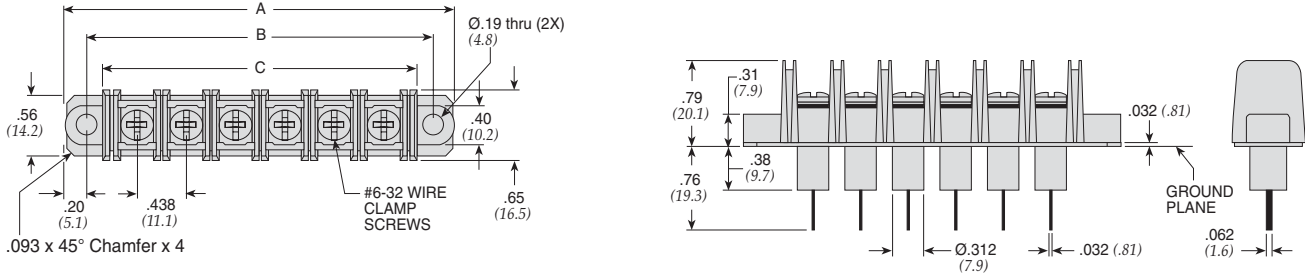

20 Amps

Dimensions in inches (mm)

Part Number	Number of Circuits	in. A (mm)	in. B (mm)	in. C (mm)
€ 52-160-002-A	2	1.71 (43.4)	1.31 (33.3)	1.02 (25.9)
52-160-003-A	3	2.15 (54.6)	1.75 (44.5)	1.46 (37.1)
52-160-004-A	4	2.59 (65.8)	2.19 (55.6)	1.90 (48.3)
52-160-005-A	5	3.02 (76.7)	2.62 (66.5)	2.32 (58.9)
52-160-006-A	6	3.46 (87.9)	3.06 (77.7)	2.77 (70.4)

€ Also available through Spectrum Control's authorized European distributors/agents.

Rear panel mount

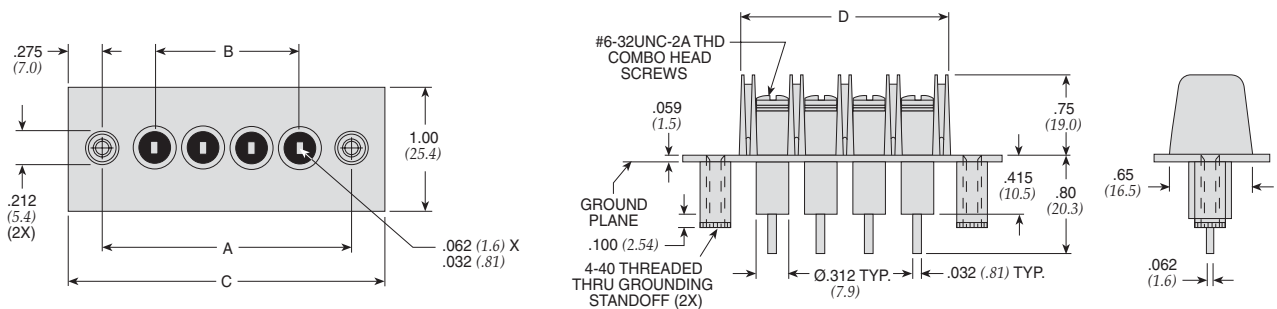

20 Amps

Dimensions in inches (mm)

Part Number	Number of Circuits	in. A (mm)	in. B (mm)	in. C (mm)	in. D (mm)
52-188-002-A	2	1.31 (33.3)	.438 (11.1)	1.86 (47.3)	1.02 (25.9)
52-188-003-A	3	1.75 (44.4)	.875 (22.2)	2.30 (58.4)	1.46 (37.1)
52-188-004-A	4	2.19 (55.6)	1.313 (33.3)	2.74 (69.5)	1.90 (48.3)
52-188-005-A	5	2.62 (66.6)	1.750 (44.4)	3.17 (80.6)	2.32 (58.9)
52-188-006-A	6	3.06 (77.7)	2.188 (55.6)	3.61 (91.7)	2.77 (70.4)