

Cannon's SMB Snap-on and SMC Screw-on subminiature coaxial connectors have been specifically engineered for high performance and high reliability applications in both military and commercial equipment operating at frequencies up to 4 GHz (SMB) and 12.4 GHz (SMC).

The Snap-on mating engagement allows a rapid connect/disconnect facility. The Screw-on mating engagement allows a low VSWR under vibration conditions and a matched impedance of 50 ohms.

Cannon SMB/SMC connectors are compatible with all SMB/SMC type connectors conforming with MIL-C-39012, BS 9210, UTE C93 561, UTE C93 562, CECC 22 130 and CECC 22 140.

In addition to this range we also offer FAKRA SMB connectors for automotive applications.



**Key Features**

- Rapid connect / disconnect (SMB)
- Standoff legs on PCB
- Frequency range to 12.4 GHz (SMC) or 4 GHz (SMB)
- Vibration withstanding design (SMC)

**MATING INTERFACES**

**SMB (SNAP-ON)**

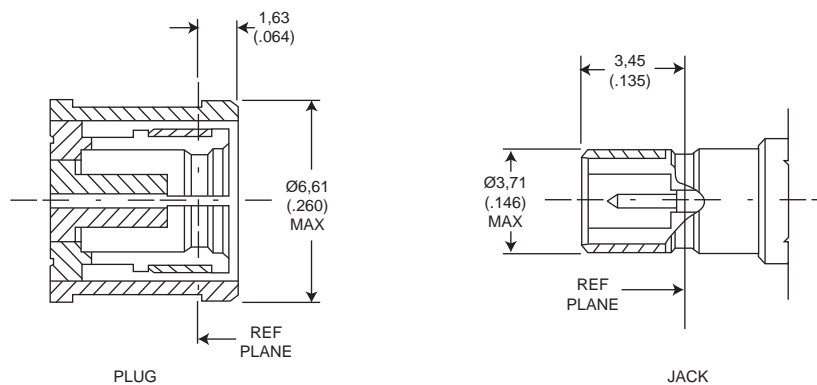

**SMC (SCREW-ON)**

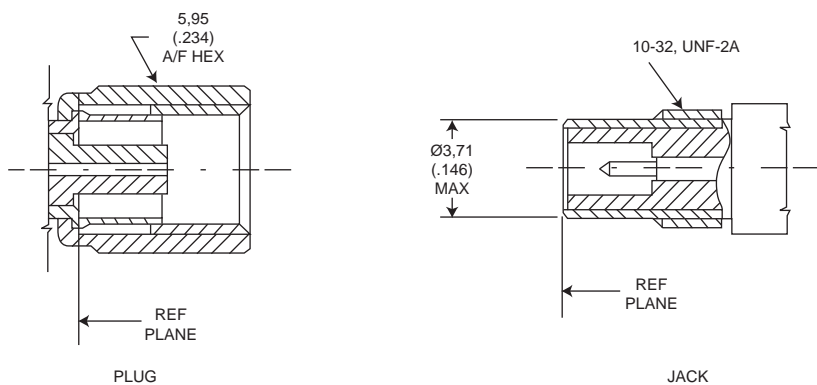

**NOTES**

1) Inside diameter of female contact to meet VSWR mating characteristics and connector durability when mated with a  $0,48 \pm 0,53$  ( $.019 \pm .021$ ) diameter male contact.

2) All undimensioned pictorial representations are for reference purposes only.

3) Slide-on versions of most SMB female styles, prefix 052, are available. For slide-on male interconnection use male SMB (snap-on type).

Dimensions shown in mm (inch)  
Specifications and dimensions subject to change

www.ittcannon.com



**SPECIFICATIONS**

ELECTRICAL	Impedance	50Ω																											
	Frequency Range	SMB = 0 to 4.0 GHz. SMC = 0 to 12.4 GHz																											
	Voltage Rating	Connectors for RG196/U series cable: At Sea Level = 300 Vrms. At 21km (70k feet) = 75 Vrms Connectors for RG188/U series cable: At Sea Level = 400 Vrms. At 21km (70k feet) = 100 Vrms																											
	Insulation Resistance	1000 MΩ minimum																											
	Contact resistance	Center Contact = 6.0 m Ω maximum initial. 8.0 m Ω maximum after environment Outer Contact = 1.0 m Ω maximum initial. 1.5 m Ω maximum after environment Braid to Body = 1.0 m Ω maximum																											
	Contact Current Rating	1.5 A dc maximum																											
	Insertion Loss	0.25 dB maximum @ 4 GHz																											
	RF Leakage	SMB = -55 dB minimum @ 2 - 3 GHz SMC = -60 dB minimum @ 2 - 3 GHz																											
	Voltage Standing Wave Ratio (VSWR) To 10 GHz or 80% of upper cut-off frequency of the cable, whichever is lower. Applicable to 50Ω cables only.(F = GHz)	<table border="1"> <thead> <tr> <th rowspan="2"></th> <th colspan="4">Connector Configuration</th> </tr> <tr> <th colspan="2">SMB</th> <th colspan="2">SMC</th> </tr> <tr> <th>Cable group</th> <th>Straight</th> <th>Right Angle</th> <th>Straight</th> <th>Right Angle</th> </tr> </thead> <tbody> <tr> <td>RG196/U Series</td> <td>1.30 + .04F</td> <td>1.45 + .06F</td> <td>1.25 + .04F</td> <td>1.40 + .06F</td> </tr> <tr> <td>RG188/U Series</td> <td>1.20 + .04F</td> <td>1.35 + .04F</td> <td>1.20 + .04F</td> <td>1.30 + .04F</td> </tr> </tbody> </table>					Connector Configuration				SMB		SMC		Cable group	Straight	Right Angle	Straight	Right Angle	RG196/U Series	1.30 + .04F	1.45 + .06F	1.25 + .04F	1.40 + .06F	RG188/U Series	1.20 + .04F	1.35 + .04F	1.20 + .04F	1.30 + .04F
		Connector Configuration																											
SMB		SMC																											
Cable group	Straight	Right Angle	Straight	Right Angle																									
RG196/U Series	1.30 + .04F	1.45 + .06F	1.25 + .04F	1.40 + .06F																									
RG188/U Series	1.20 + .04F	1.35 + .04F	1.20 + .04F	1.30 + .04F																									
MECHANICAL	Engagement Design	SMB per MIL-C-39012, Series SMB. SMC per MIL-C-39012, Series SMC.																											
	Engagement Forces	SMB: Initial = 62 N (14 lbs.) max. engagement. After 500 matings = 62 N (14 lbs.) max. engagement and disengagement = 8.9 N (2 lbs.) min. disengagement. SMC: 0.11 Nm (16 in. oz. ) torque max.																											
	Mating Torque	SMB: N/A SMC: 0.42 to 0.50 Nm (60 to 70 in.oz)																											
	Locknut Torque	0.56 to 0.64 Nm (80 to 90 in. oz)																											
	Coupling Nut Retention	SMB: N/A SMC: 155 N (35 lbs. ) minimum																											
	Materials	Body, Body Components and Male Contacts: Brass, half hard. Female Contacts: Beryllium Copper, heat treated. Insulators: PTFE. Lockwashers: Phosphor Bronze. Crimp Ferrule: Annealed copper alloy. Gaskets: Silicone rubber																											
ENVIRONMENTAL	Finish/Plating	Center Contacts: Gold plated. Other Metal Parts: Gold plated or nickel plated (as specified) to meet the finish and corrosion requirements of MIL-C-39012																											
	Temperature Rating	-65° C to 165° C																											
	Corrosion (salt spray)	MIL-STD-202, Method 101, test condition B, 5% salt solution																											
	Vibration, High Frequency	MIL-STD-202, Method 204, SMB: test condition B (15 G's). SMC: test condition D (20 G's)																											
	Shock	MIL-STD-202, Method 213, SMB: test condition B, 75 G's @ 6 milliseconds, 1/2 sine. SMC: test condition C, 100 G's @ 6 milliseconds, 1/2 sine.																											
	Thermal Shock	MIL-STD-202, Method 107, test condition B, except high temperature shall be 85°C. High temperature shall be 200°C for connectors using 200°C cables.																											
GENERAL	Moisture Resistance	MIL-STD-202, Method 106, when interface gasket is used. No measurement at high humidity. Insulation resistance shall be 200 MΩ minimum within five minutes after removal from humidity.																											
	Connector Durability	500 matings minimum																											
	Contact Captivation	Unless otherwise specified, all connectors feature captivated contacts. When captivated the contacts will withstand 17,8 N (4 lbs.) minimum axial force. CECC 22 130 = 10 N(2.25 lb.)																											
	Cable Retention	When properly assembled to the compatible single braided coaxial cable, the retention is equal to the breaking strength of the cable.																											
Body Plating Options	The following part number suffixes can be specified for SMB/SMC Connectors:																												
	..... 220	gold body																											
	..... 910	nickel body																											
	..... C90	nickel body																											

**STRAIGHT PLUGS AND JACKS**

Straight Crimp Plug

Part Number	Cable Numbers
B51 - 024 - 0000220	RG174/U, 316/U
B51 - 024 - 3196220	RG178/U, 196/U
B51 - 024 - 9399220	RD316, 179

Straight Crimp Bulkhead Jack

Part Number	Cable Numbers
051 - 027 - 0000220	RG174/U, 316/U
051 - 027 - 3196220	RG178/U, 196/U
051 - 027 - 9399220	RD316, 179

**RIGHT ANGLE PLUGS**

Right Angle Crimp Plug

Part Number	Cable Numbers
B51 - 328 - 3188220	RG174/U, 316/U
B51 - 328 - 3196220	RG178/U, 196/U
B51 - 328 - 9399220	RD316, 179
B51 - 328 - 9019AU0	BT3002, T2C75024

**IN-SERIES ADAPTORS**

Jack to Jack Adaptor, Bulkhead Mounting

Part Number
051 - 075 - 0000220

SMB connectors have solder center contacts.

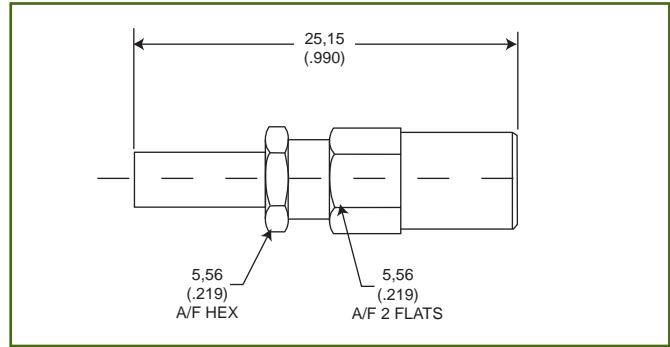

Assembly Instructions BAI-003 (Page 50)

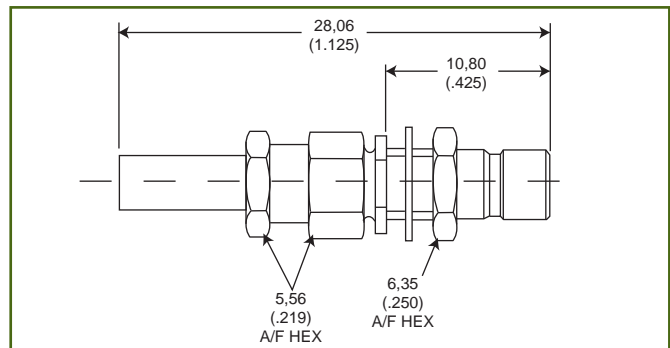

Mounting Plan V (Page 40)  
Assembly Instructions BAI-003 (Page 50)

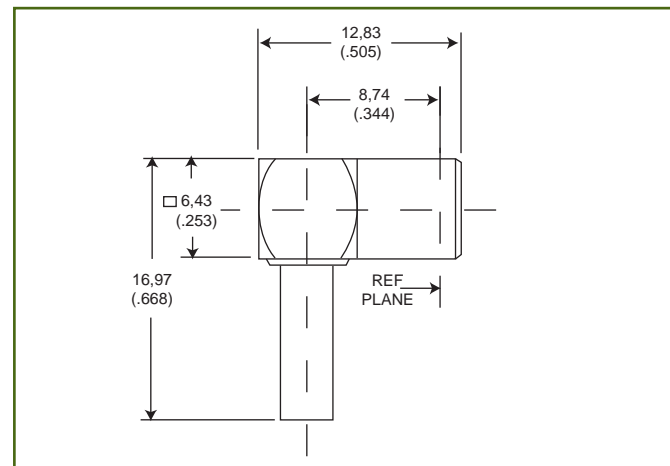

Assembly Instructions BAI-015 (Page 49)

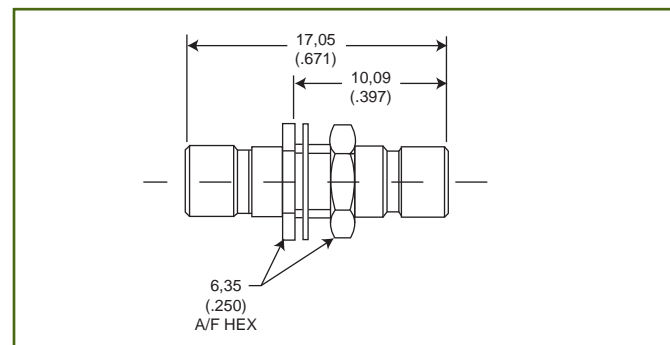

Mounting Plan V (Page 40)

Dimensions shown in mm (inch)  
Specifications and dimensions subject to change  
www.ittcannon.com



**BULKHEAD JACKS**

Straight Bulkhead Jack, Solder Pot,  
Mounting Nut Outside Panel

Part Number
051 - 043 - 0000220

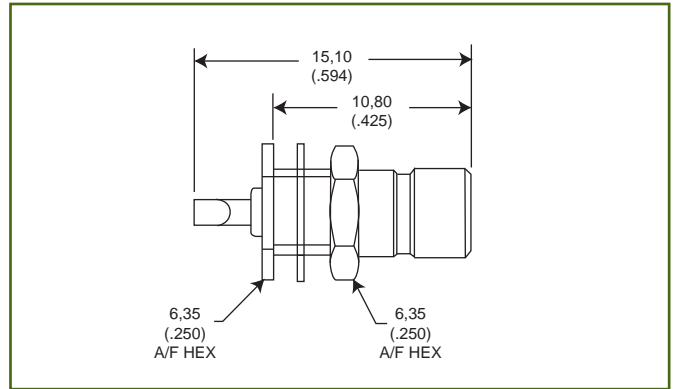

Mounting Plan V (Page 40)

Straight Bulkhead Jack, Solder Pot,  
Mounting Nut Inside Panel

Part Number
051 - 045 - 0000220

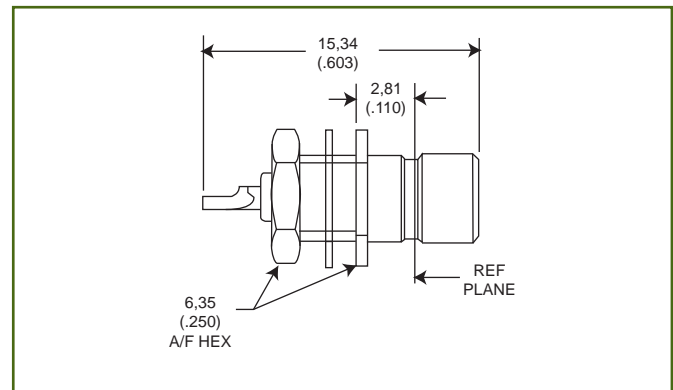

Mounting Plan V (Page 40)

Right Angle Bulkhead Jack, Solder Pot,  
Mounting Nut Inside Panel

Part Number
051 - 047 - 0000220

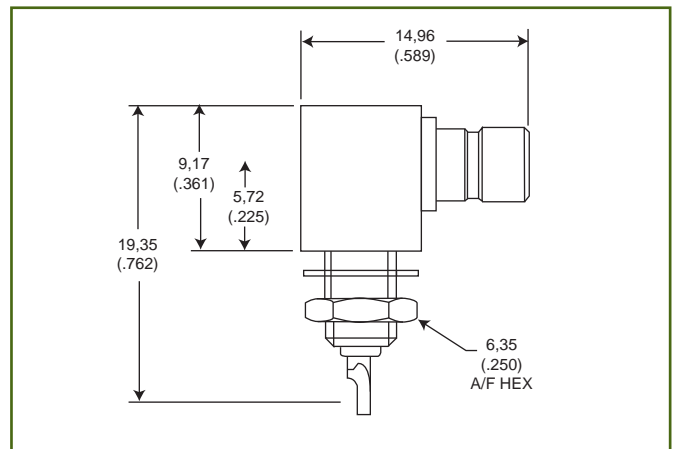

Mounting Plan V (Page 40)



**PRINTED CIRCUIT BOARD JACKS**

SMB PCB preferred styles feature stepped legs. This allows the jacks to be raised from the surface of the PCB, thereby preventing the accumulation of soldering fluids and foreign bodies. A single piece conductor overcomes the problem of internal joint separation during continuous wave / flow soldering operations.

Straight PCB Jack, 1,00 (.039) sq Legs

Part Number
B51 - 351 - 0000220

Straight PCB Jack, 0,81 (.032) sq Legs

Part Number
B51 - 051 - 9029220

Right Angle PCB Jack, 1,00 (.039) sq Legs

Part Number
B51 - 053 - 0000220

Right Angle PCB Jack, 0,81 (.032) sq Legs

Part Number
B51 - 053 - 9029220

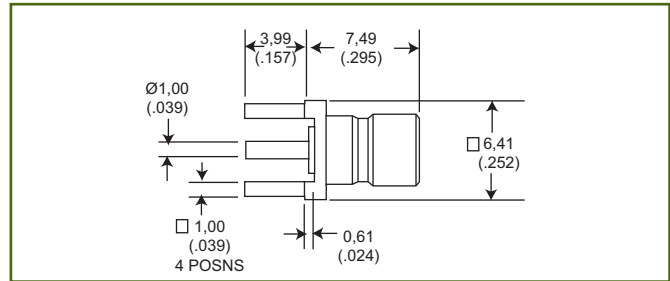

Mounting Plan A (Page 40)

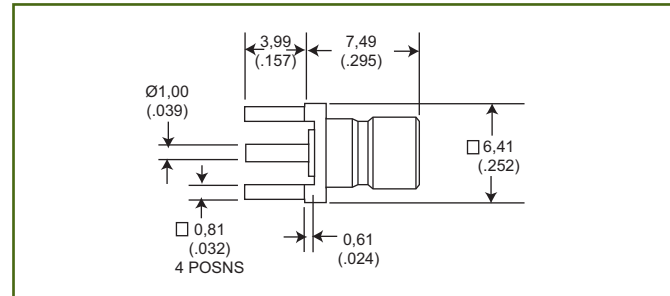

Mounting Plan B (Page 40)

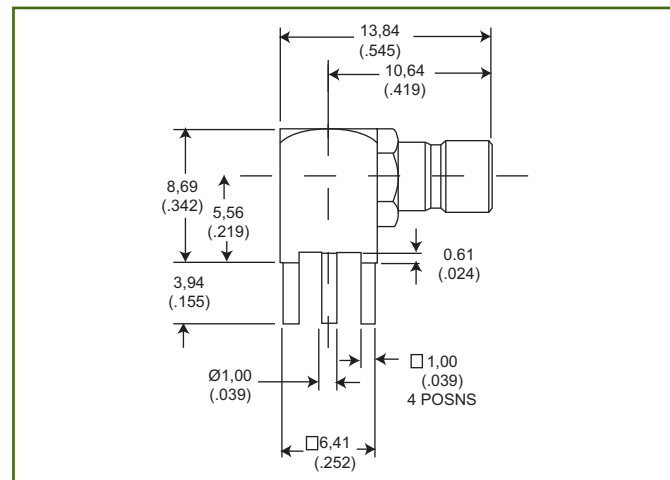

Mounting Plan A (Page 40)

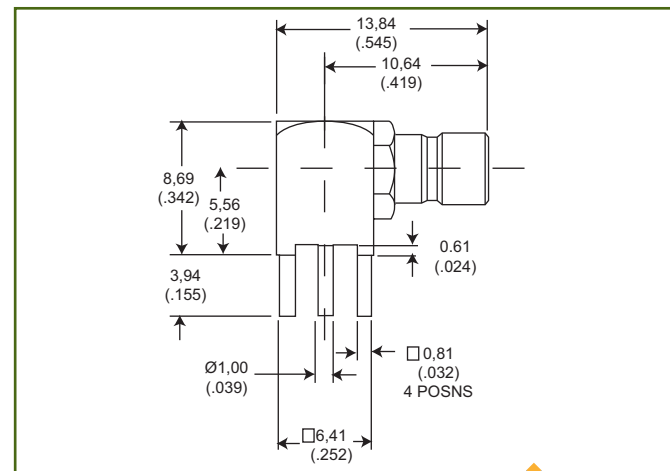

Mounting Plan B (Page 40)



Dimensions shown in mm (inch)  
Specifications and dimensions subject to change

**STRAIGHT PLUGS AND JACKS**

Straight Clamp Plug

Part Number	Cable Numbers
050 - 007 - 0000220	RG174/U, 316/U

Straight Crimp Plug

Part Number	Cable Numbers
050 - 024 - 0000220	RG174/U, 316/U

Straight Crimp Bulkhead Jack

Part Number	Cable Numbers
050 - 027 - 0000220	RG174/U, 316/U

**RIGHT ANGLE PLUGS**

Right Angle Crimp Plug

Part Number	Cable Numbers
B50 - 328 - 3188220	RG174/U, 316/U
B50 - 328 - 9399220	RD316, 179

SMC CONNECTORS HAVE SOLDER CENTER CONTACTS

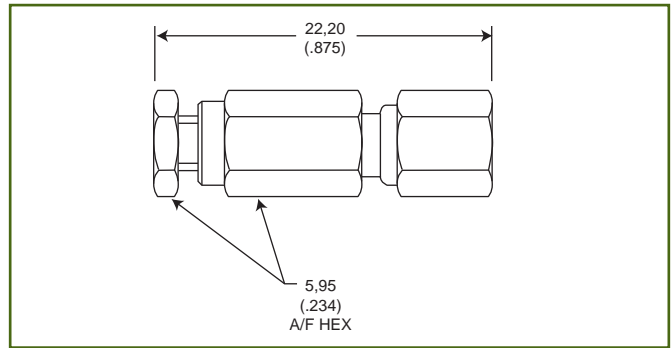

Assembly Instructions BAI-001 (Page 52)

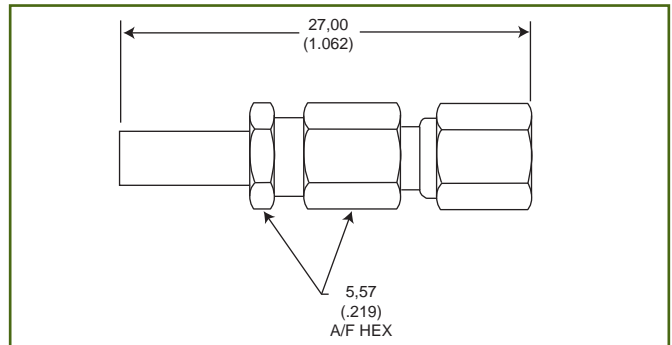

Assembly Instructions BAI-003 (Page 50)

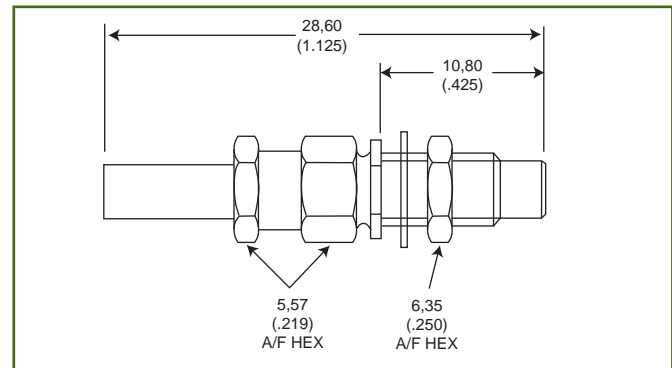

Mounting Plan V (Page 40)  
Assembly Instructions BAI-003 (Page 50)

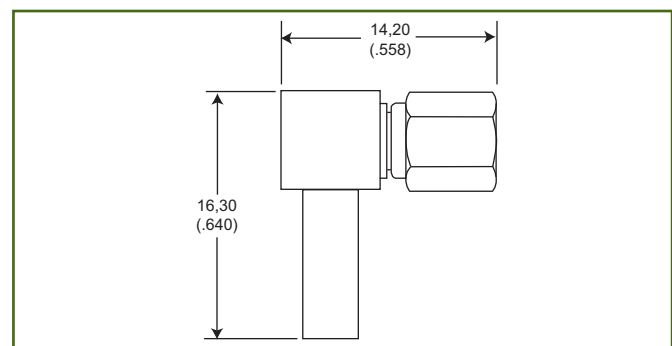

Assembly Instructions  
BAI-015 (Page 49)



**BULKHEAD JACKS**

Straight Bulkhead Jack, Solder Pot,  
Mounting Nut outside Panel

Part Number
050 - 043 - 0000220

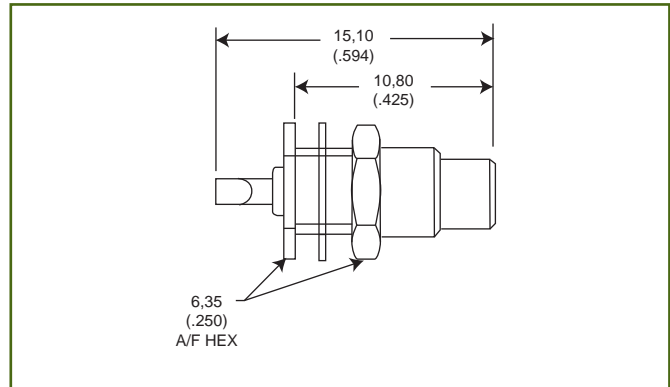

Mounting Plan V (Page 40)

Straight Bulkhead Jack, Solder Pot ,  
Mounting Nut inside Panel

Part Number
050 - 045 - 0000220

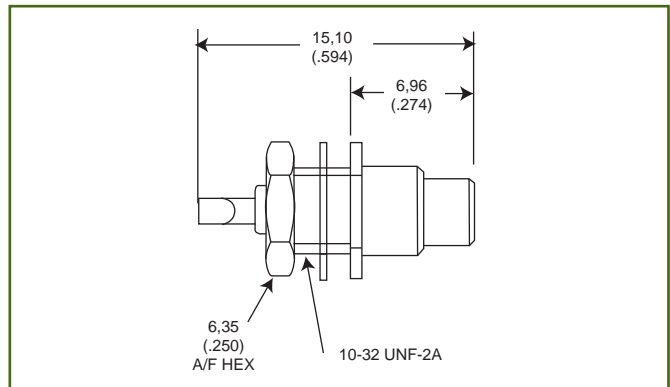

Mounting Plan V (Page 40)

Right Angle Bulkhead Jack, Solder Pot,  
Mounting Nut inside Panel

Part Number
050 - 047 - 0000220

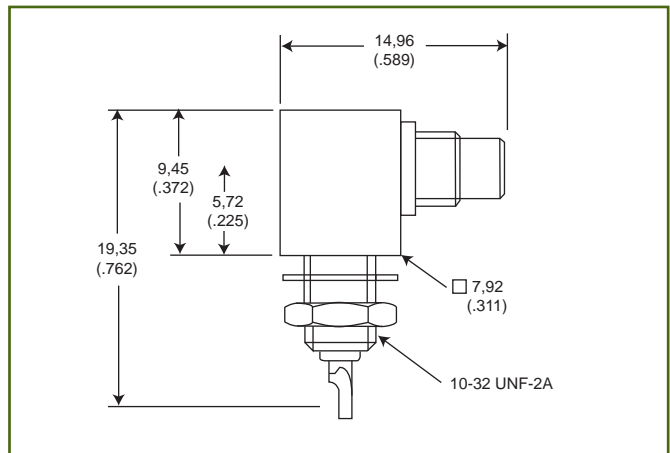

Mounting Plan V (Page 40)

Dimensions shown in mm (inch)  
Specifications and dimensions subject to change

**PRINTED CIRCUIT BOARD JACKS**

SMC PCB preferred styles feature stepped legs. This allows the jacks to be raised from the surface of the PCB, thereby preventing the accumulation of soldering fluids and foreign bodies. A single piece conductor overcomes the problem of internal joint separation during continuous wave/flow soldering operations.

Straight PCB Jack, 1,00 (.039) square legs

Part Number
B50 - 051 - 0000220

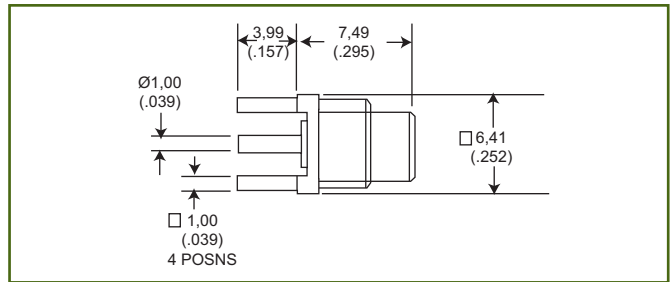

Mounting Plan A (Page 40)

Straight PCB Jack, 0,81 (.032) square legs

Part Number
B50 - 051 - 9019220

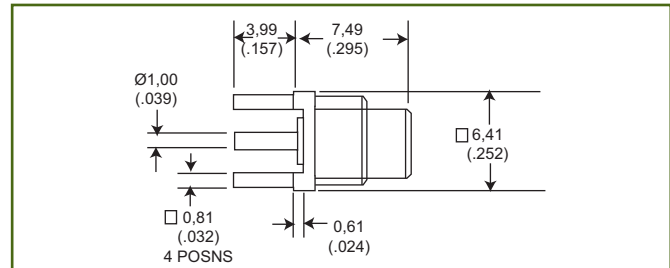

Mounting Plan B (Page 40)

Right Angle PCB Jack, 1,00 (.039) square legs

Part Number
B50 - 053 - 0000220

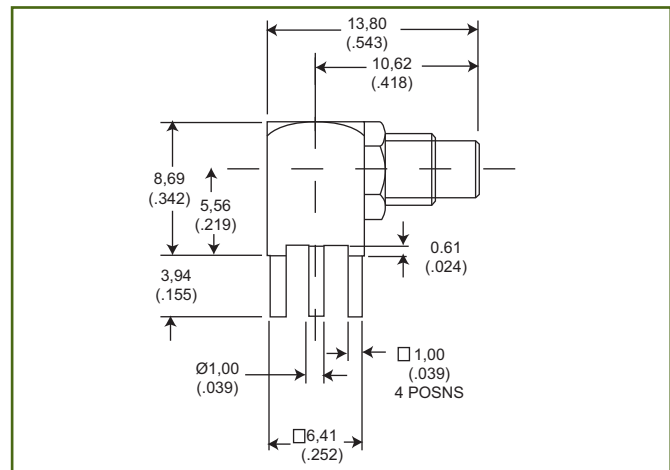

Mounting Plan A (Page 40)

Right Angle PCB Jack, 0,81 (.032) sq Legs

Part Number
B50 - 053 - 9019220

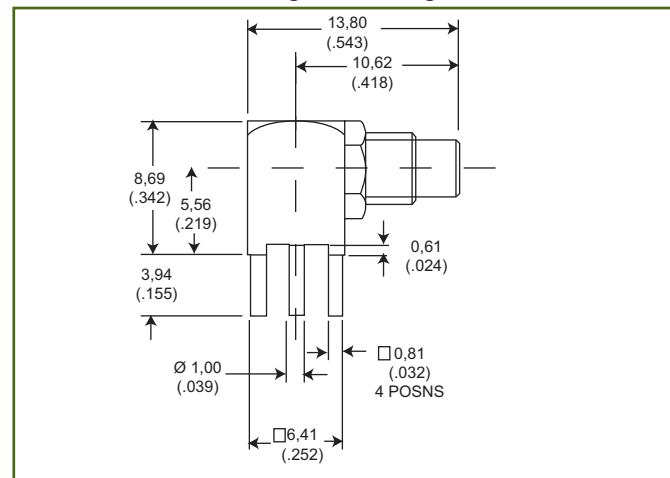

Mounting Plan B (Page 40)

