

Cree® XLamp® XT-E Royal Blue LEDs

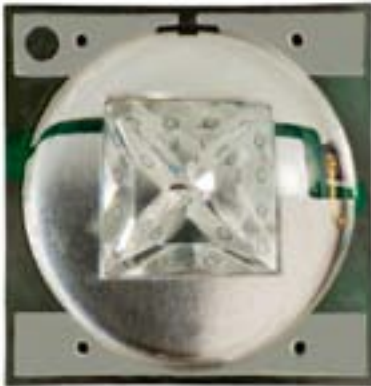

PRODUCT DESCRIPTION

XLamp XT-E Royal Blue is a high performing source of royal blue light for remote phosphor applications and sets new standards of efficiency and light extraction in Royal Blue LEDs. The XT-E Royal Blue is designed to enable faster adoption of LED light in high efficacy lighting products. Compared to the standard XLamp XP-E Royal Blue, the XT-E Royal Blue is up to 20% more efficient.

Cree XLamp LEDs bring high performance and quality of light to a wide range of lighting applications, including remote phosphor, color-changing, portable and personal, outdoor, indoor-directional, transportation, stage and studio, commercial and emergency-vehicle lighting.

NOTE: For remote phosphor applications, a separate license to certain Cree patents is required.

FEATURES

- Sorted into 2.5 nm wavelength bins
- Binned at 85°C
- Low thermal resistance: 5°C/W
- Wide viewing angle: 140°
- Maximum drive current: 1000 mA
- Maximum junction temperature: 150°C
- Electrically neutral thermal path
- Vf binning
- Unlimited floor life at ≤ 30°C/85% RH
- Reflow solderable - JEDEC J-STD-020C Compatible

TABLE OF CONTENTS

Product Characteristics.....	2
Flux Characteristics, Standard Order Codes and Bins - Royal Blue (T _j = 85° C).....	2
Relative Spectral Power Distribution.....	3
Relative Flux vs. Junction Temperature	3
Electrical Characteristics.....	4
Relative Flux vs. Current	4
Typical Spatial Distribution.....	5
Thermal Design.....	5
Performance Groups - Radiant Flux (T _j = 85° C).....	6
Performance Groups - Dominant Wavelength (T _j = 85° C).....	6
Performance Groups - Forward Voltage (T _j = 85° C).....	6
Bin and Order Code Formats	7
Reflow Soldering Characteristics ..	7
Notes.....	8
Mechanical Dimensions.....	9
Tape and Reel	10
Packaging.....	11

PRODUCT CHARACTERISTICS

Characteristics	Unit	Minimum	Typical	Maximum
Thermal Resistance, junction to solder point	°C/W		5	
Viewing Angle (FWHM)	degrees		140	
Temperature coefficient of voltage	mV/°C		-3.0	
ESD Classification (HBM per Mil-Std-883D)			Class 2	
DC Forward Current	mA		350	1000
Reverse Voltage	V			5
Forward Voltage (@ 350 mA)	V		2.85	3.5
Reverse Current	mA			-0.1
LED junction temperature	°C			150

FLUX CHARACTERISTICS, STANDARD ORDER CODE AND BINS - ROYAL BLUE (T_j = 85°C)

The following table provides order codes for XLamp XT-E Royal Blue LEDs. Additional information on the performance grouping and codes for XT-E Royal Blue LEDs is on page 6.

Color	DWL Kit Codes	Dominant Wavelength Range				Order Code, Minimum Radiant Flux @ 350 mA, T _j =85° C	
		Min.		Max.		Flux 475 mW	Flux 500 mW
		Group	DWL (nm)	Group	DWL (nm)		
Royal Blue	01	D36	450	D57	465	XTEARY-00-0000-000000K01	XTEARY-00-0000-000000L01
	02	D36	450	D47	460	XTEARY-00-0000-000000K02	XTEARY-00-0000-000000L02
	03	D46	455	D57	465	XTEARY-00-0000-000000K03	XTEARY-00-0000-000000L03
	04	D36	450	D37	455	XTEARY-00-0000-000000K04	XTEARY-00-0000-000000L04
	05	D46	455	D47	460	XTEARY-00-0000-000000K05	XTEARY-00-0000-000000L05
	06	D56	460	D57	465	XTEARY-00-0000-000000K06	XTEARY-00-0000-000000L06
	07	D37	452.5	D46	457.5	XTEARY-00-0000-000000K07	XTEARY-00-0000-000000L07
	08	D47	457.5	D56	462.5	XTEARY-00-0000-000000K08	XTEARY-00-0000-000000L08
	09	D37	452.5	D56	462.5	XTEARY-00-0000-000000K09	XTEARY-00-0000-000000L09

Notes:

- Cree maintains a tolerance of ±7% on flux and power measurements

RELATIVE SPECTRAL POWER DISTRIBUTION

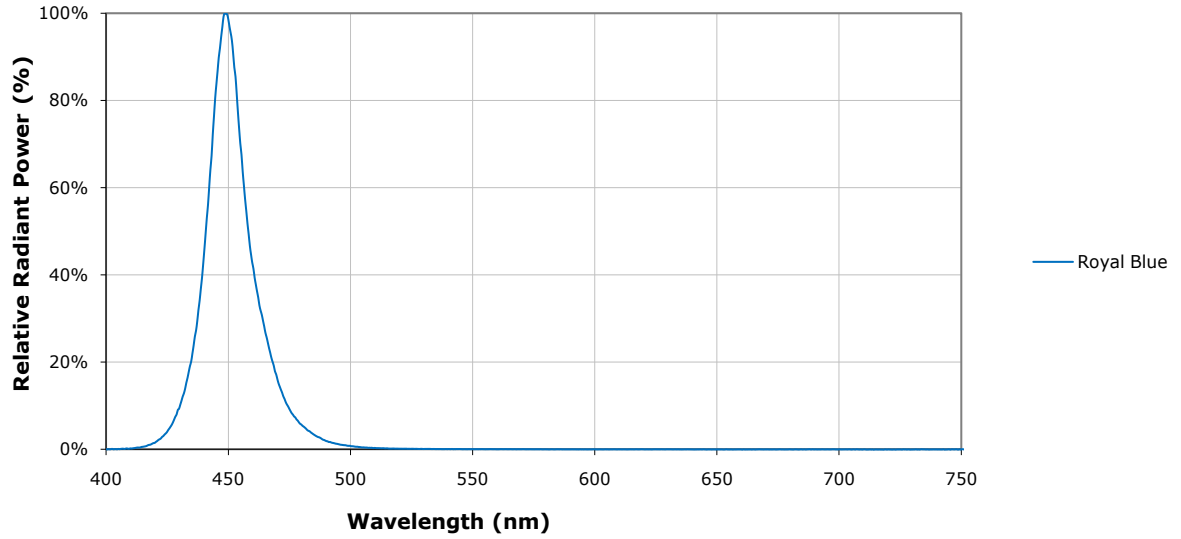

RELATIVE RADIANT FLUX VS. JUNCTION TEMPERATURE ($I_F = 350$ MA)

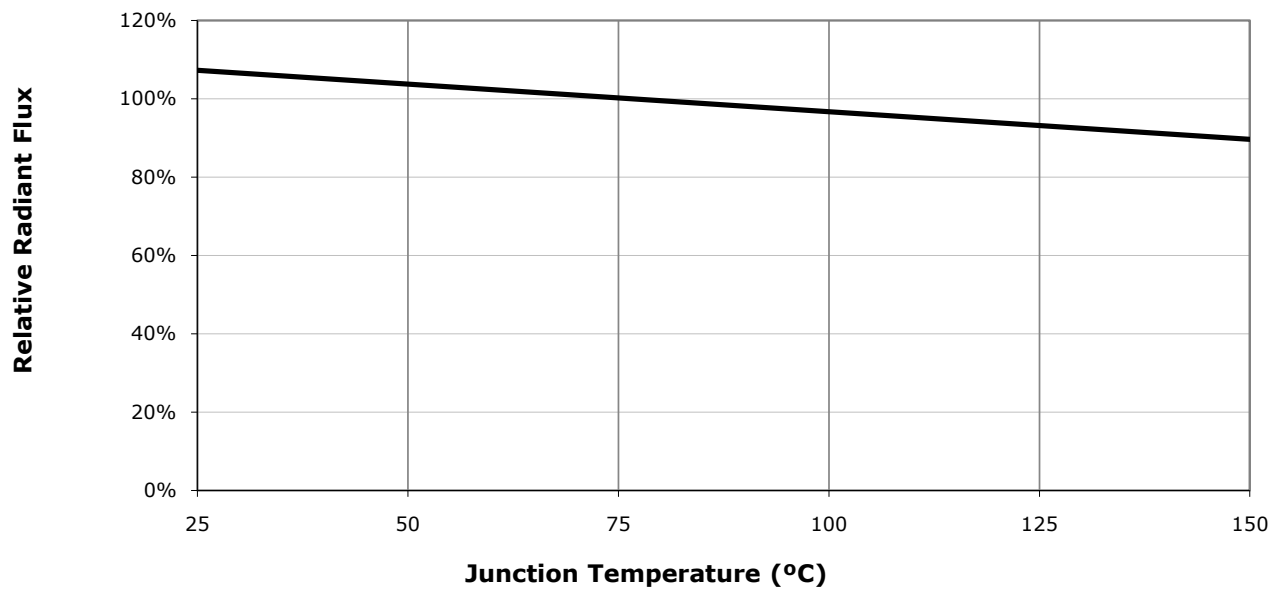

ELECTRICAL CHARACTERISTICS ($T_j = 85^\circ\text{C}$)

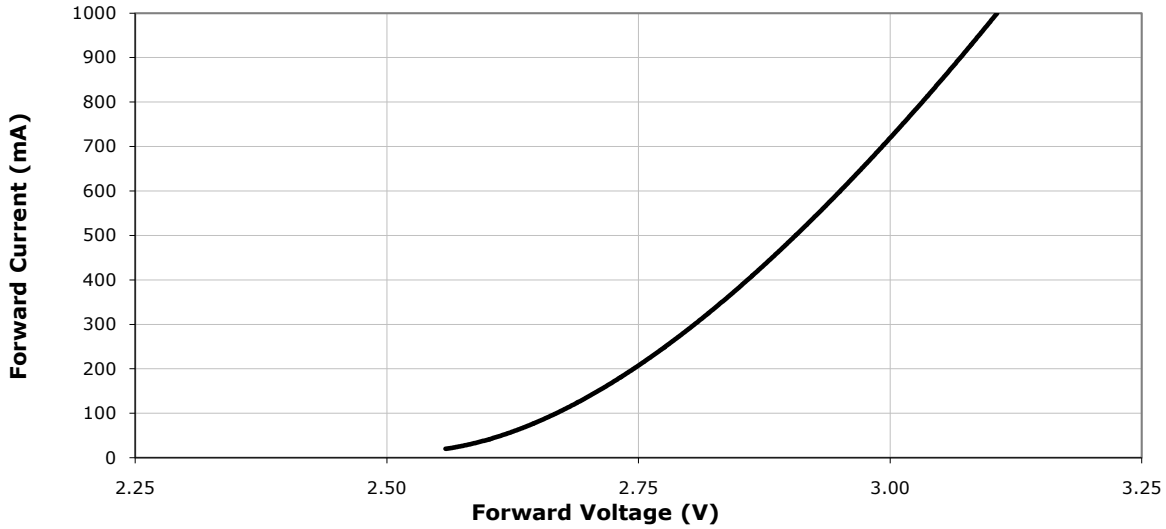

RELATIVE RADIANT FLUX VS. CURRENT ($T_j = 85^\circ\text{C}$)

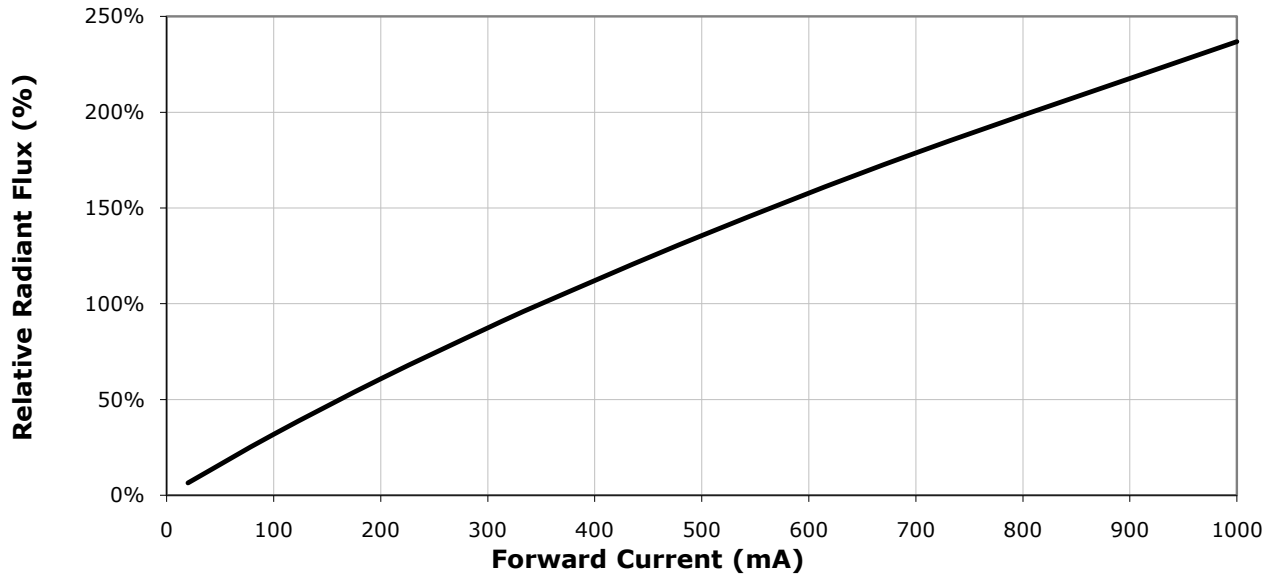

TYPICAL SPATIAL DISTRIBUTION

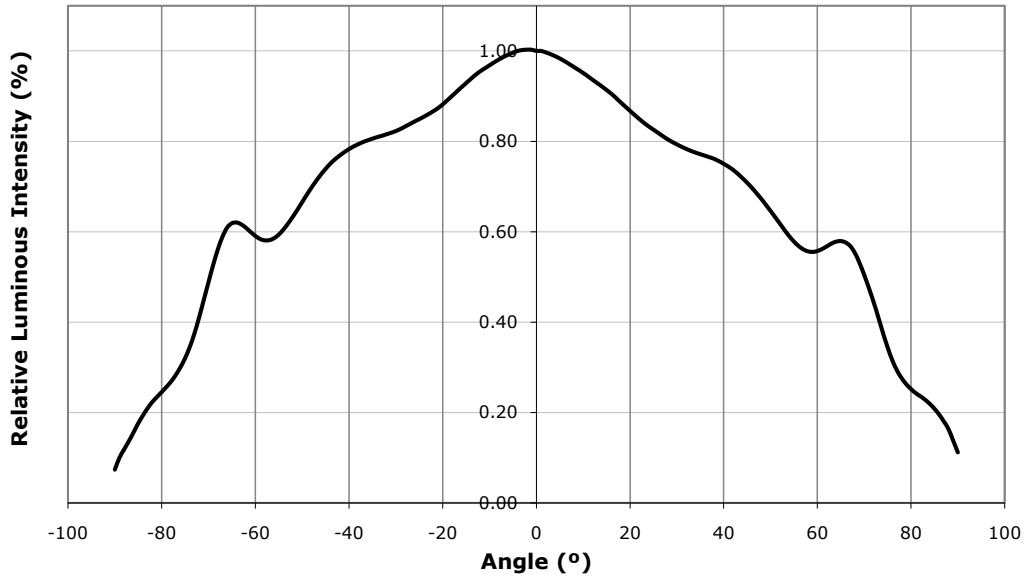

THERMAL DESIGN

The maximum forward current is determined by the thermal resistance between the LED junction and ambient. It is crucial for the end product to be designed in a manner that minimizes the thermal resistance from the solder point to ambient in order to optimize lamp life and optical characteristics.

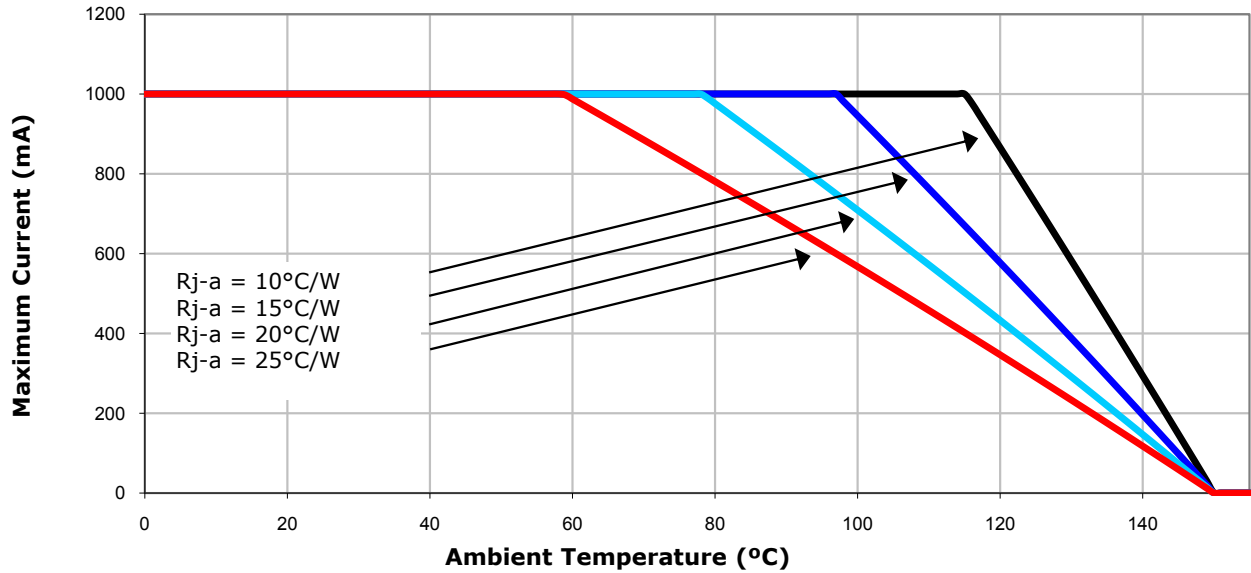

PERFORMANCE GROUPS – RADIANT FLUX ($T_j = 85^\circ\text{C}$)

XLamp XT-E Royal Blue LEDs are tested for radiant flux and placed into one the following bins.

Group Code	Minimum Radiant Flux (mW)	Maximum Radiant Flux (mW)
31	475	500
32	500	525
33	525	550

PERFORMANCE GROUPS – DOMINANT WAVELENGTH ($T_j = 85^\circ\text{C}$)

XLamp XT-E Royal Blue LEDs are tested for dominant wavelength and placed into one of the regions defined by the following bounding coordinates.

Group Code	Minimum Dominant Wavelength (nm)	Maximum Dominant Wavelength (nm)
D36	450.0	452.5
D37	452.5	455.0
D46	455.0	457.5
D47	457.5	460.0
D56	460.0	462.5
D57	462.5	465.0

PERFORMANCE GROUPS – FORWARD VOLTAGE ($T_j = 85^\circ\text{C}$)

XLamp XT-E Royal Blue LEDs are tested for forward voltage and placed into one the following voltage bins.

Group Code	Minimum Forward Voltage (V)	Maximum Forward Voltage (V)
F	2.75	3.00
G	3.00	3.25
H	3.25	3.50

BIN AND ORDER CODE FORMAT

Bin codes and order codes are configured as follows:

Order Code

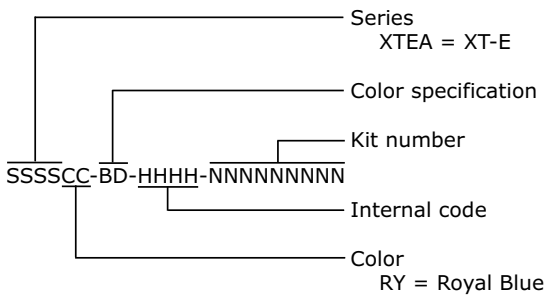

Bin Code

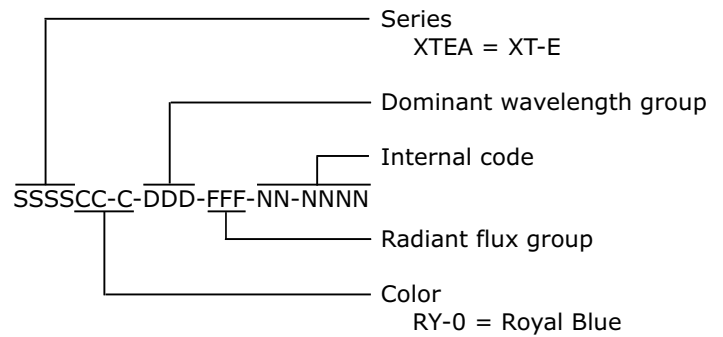

REFLOW SOLDERING CHARACTERISTICS

In testing, Cree has found XLamp XT-E LEDs to be compatible with JEDEC J-STD-020C, using the parameters listed below. As a general guideline, Cree recommends that users follow the recommended soldering profile provided by the manufacturer of solder paste used.

Note that this general guideline may not apply to all PCB designs and configurations of reflow soldering equipment.

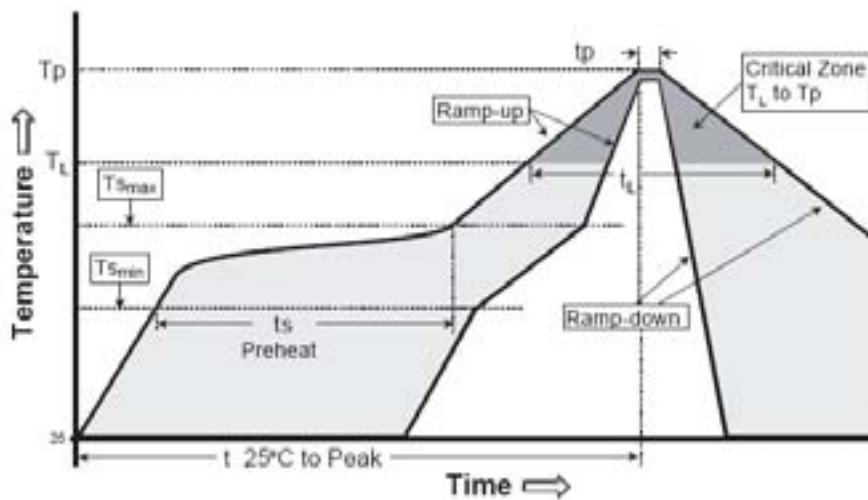

IPC/JEDEC J-STD-020C

Profile Feature	Lead-Based Solder	Lead-Free Solder
Average Ramp-Up Rate ($T_{s_{max}}$ to T_p)	3°C/second max.	3°C/second max.
Preheat: Temperature Min ($T_{s_{min}}$)	100°C	150°C
Preheat: Temperature Max ($T_{s_{max}}$)	150°C	200°C
Preheat: Time ($t_{s_{min}}$ to $t_{s_{max}}$)	60-120 seconds	60-180 seconds
Time Maintained Above: Temperature (T_L)	183°C	217°C
Time Maintained Above: Time (t_L)	60-150 seconds	60-150 seconds
Peak/Classification Temperature (T_p)	215°C	260°C
Time Within 5°C of Actual Peak Temperature (t_p)	10-30 seconds	20-40 seconds
Ramp-Down Rate	6°C/second max.	6°C/second max
Time 25°C to Peak Temperature	6 minutes max.	8 minutes max.

Note: All temperatures refer to the topside of the package, measured on the package body surface.

NOTES

Moisture Sensitivity

In testing, Cree has found XLamp XT-E LEDs to have unlimited floor life in conditions $\leq 30^\circ\text{C}$ / 85% relative humidity (RH). Moisture testing included a 168-hour soak at 85°C / 85% RH followed by 3 reflow cycles, with visual and electrical inspections at each stage.

Vision Advisory Claim

WARNING: Do not look at exposed lamp in operation. Eye injury can result. See LED Eye Safety at http://www.cree.com/products/pdf/XLamp_EyeSafety.pdf.

MECHANICAL DIMENSIONS

All measurements are $\pm .13$ mm unless otherwise indicated.

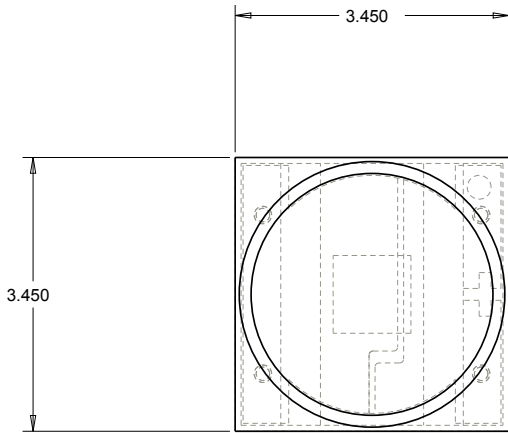

Top View

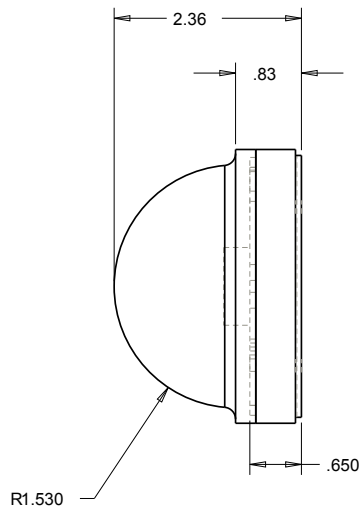

Side View

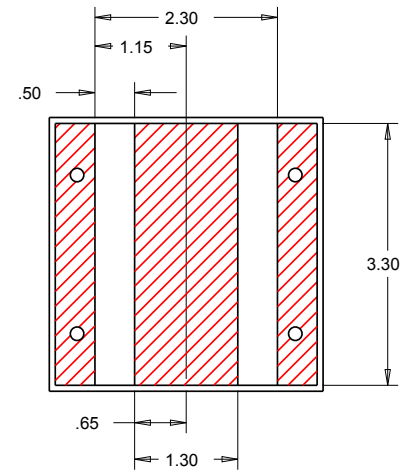

Bottom View

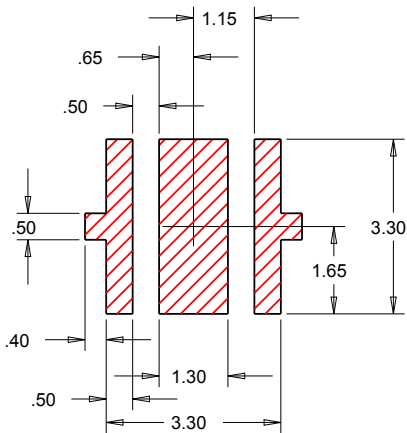

Recommended PCB Solder Pad

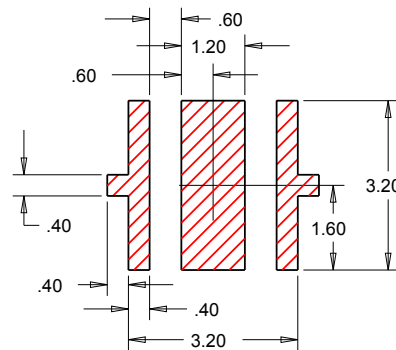

**Recommended Stencil Pattern
(Shaded Area Is Open)**

TAPE AND REEL

All dimensions in mm.

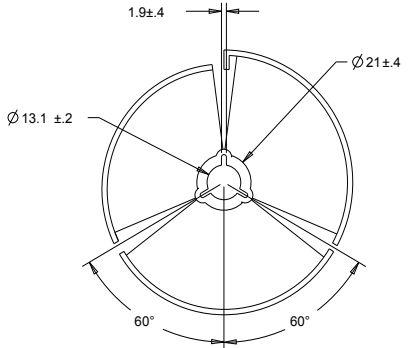
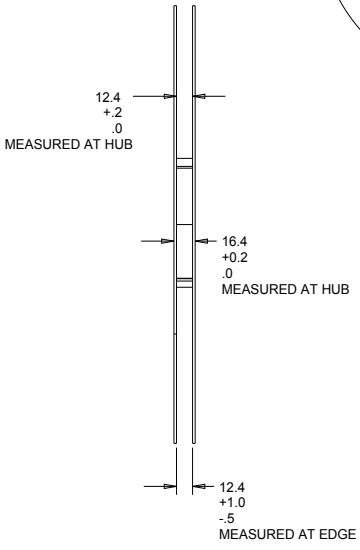
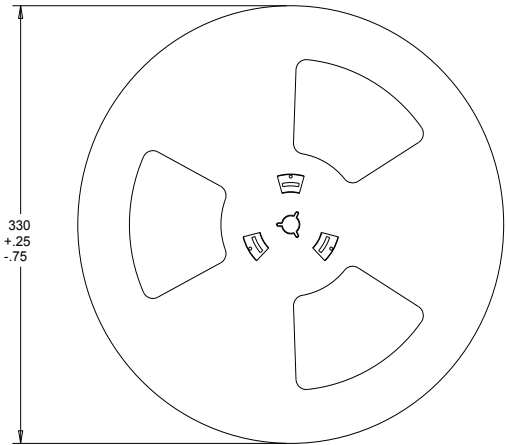
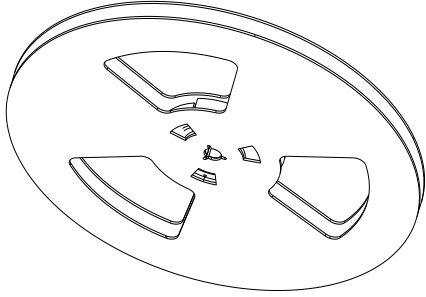
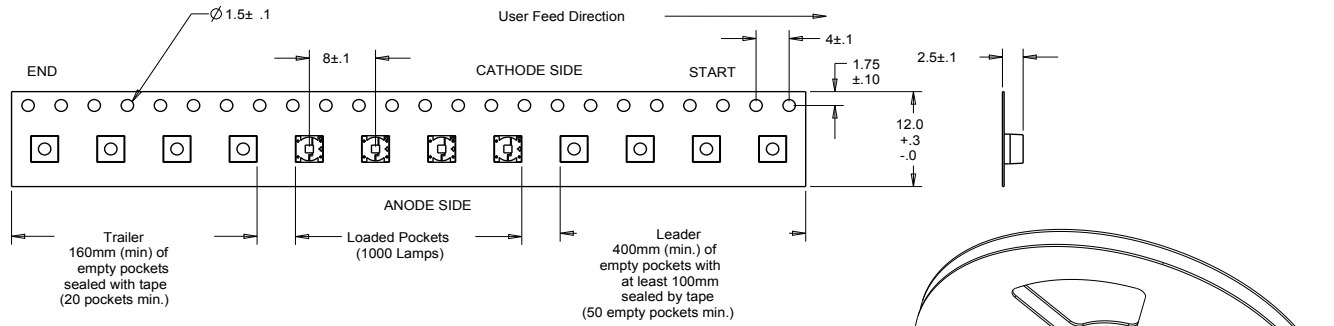
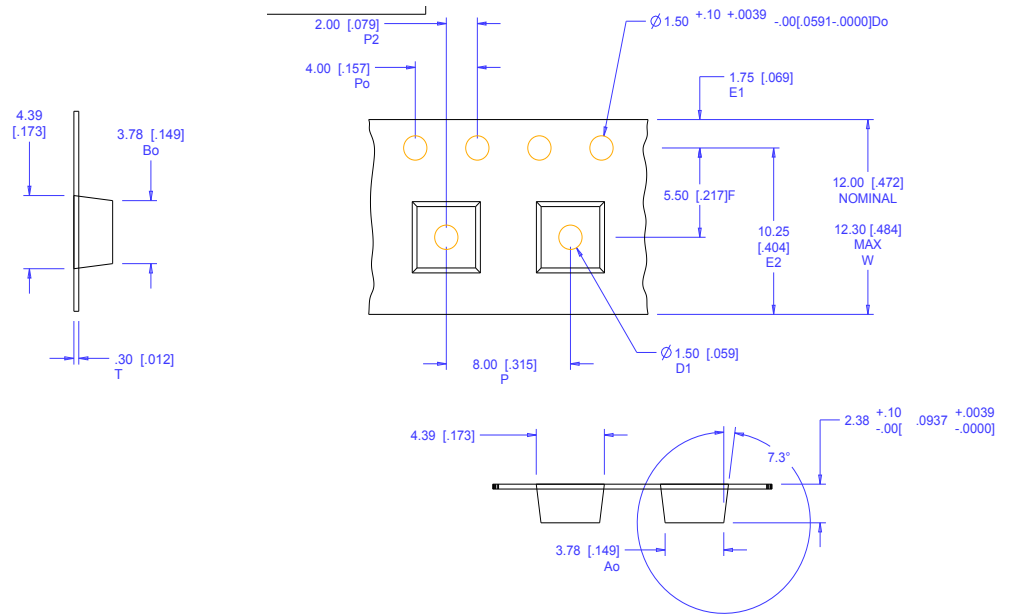

PACKAGING

