

# HLMP-CB18

T-1<sup>3</sup>/<sub>4</sub> (5 mm) Super Bright Precision  
Optical Performance InGaN LED Lamps



## Data Sheet

**HLMP-CB18, HLMP-CB19, HLMP-CM18,  
HLMP-CM19, HLMP-CE18, HLMP-CE19,  
HLMP-CB28, HLMP-CB29, HLMP-CM28,  
HLMP-CM29, HLMP-CE28, HLMP-CE29,  
HLMP-CB38, HLMP-CB39, HLMP-CM38,  
HLMP-CM39, HLMP-CE38, HLMP-CE39**

### Description

These Super Bright Precision Optical Performance LED lamps are based on flip chip InGaN material, which is the brightest and most efficient technology for LEDs in the blue, green, and cyan region of the spectrum. The 470 nm typical dominant wavelength for blue and 530 nm typical wavelength for green is well suited to color mixing in full color signs. The 500 nm typical dominant wavelength for cyan is suitable for traffic signal application.

These LED lamps are untinted, non-diffused, T-1<sup>3</sup>/<sub>4</sub> packages incorporating second generation optics producing well defined spatial radiation patterns at specific viewing cone angles.

These lamps are made with an advanced optical grade epoxy, offering superior temperature and moisture resistance in outdoor signal and sign applications. The high maximum LED junction temperature limit of +130°C enables high temperature operation in bright sunlight conditions. The package epoxy contains both UV-a and UV-b inhibitors to reduce the effects of long-term exposure to direct sunlight.

### Features

- **Well defined spatial radiation pattern**
- **High luminous output**
- **Available in blue green and cyan color**
- **Viewing angle: 15°, 23° and 30°**
- **Standoff or non-standoff leads**
- **Superior resistance to moisture**
- **New InGaN flip chip die technology with protective diode**
- **ESD class 3**

### Applications

- **Traffic signals**
- **Commercial outdoor advertising**
- **Front panel backlighting**
- **Front panel indicators**

# Package Dimensions

**PACKAGE DIMENSION A**

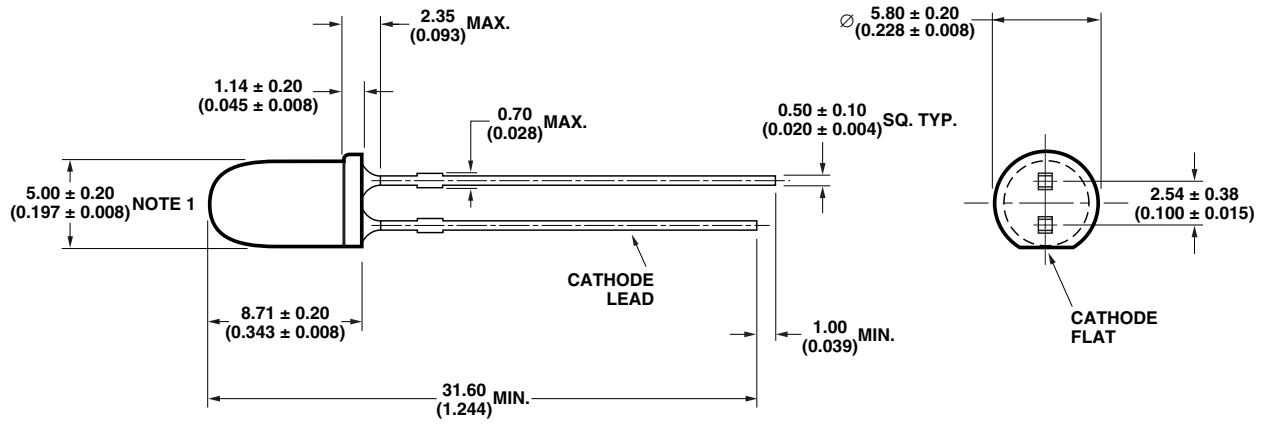

**PACKAGE DIMENSION B**

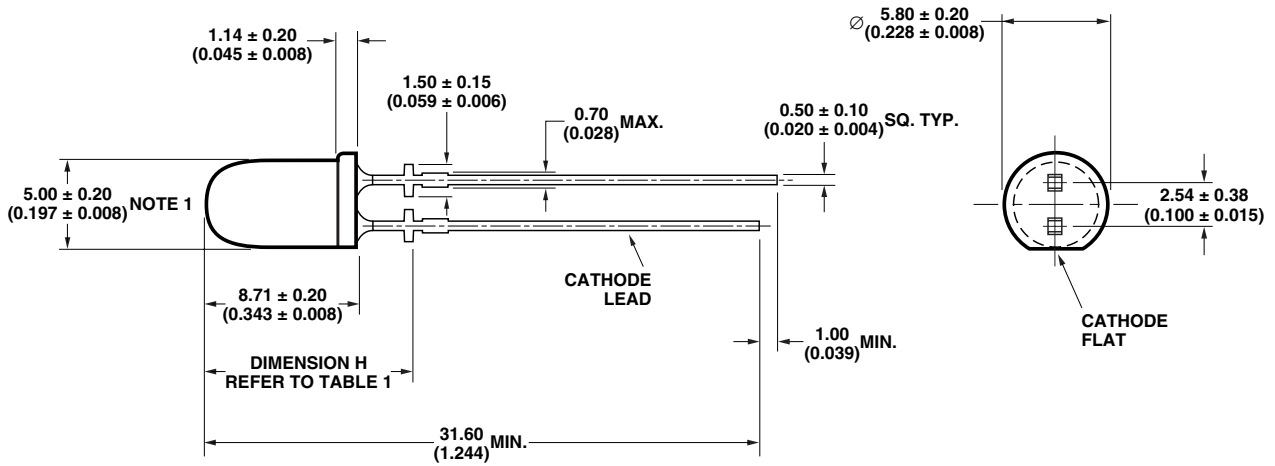

**NOTES:**

- 1. MEASURED JUST ABOVE FLANGE.
- 2. DIMENSIONS IN MILLIMETERS (INCHES).

DIMENSION H:	
23 & 30 DEGREE	= 12.67 ± 0.25 mm (0.499 ± 0.01 INCH)
15 DEGREE	= 12.93 ± 0.25 mm (0.509 ± 0.01 INCH)

## Device Selection Guide

Part Number	Color	Typical Viewing Angle (Degree)	Intensity (cd) at 20 mA			Standoff	Package Dimension
			Min.	Typ.	Max.		
HLMP-CB18-TW0xx	Blue	15	2.50	3.50	7.20	No	A
HLMP-CB19-TW0xx	Blue	15	2.50	3.50	7.20	Yes	B
HLMP-CM18-X10xx	Green	15	7.20	12.0	21.0	No	A
HLMP-CM19-X10xx	Green	15	7.20	12.0	21.0	Yes	B
HLMP-CE18-WZ0xx	Cyan	15	5.50	11.8	16.0	No	A
HLMP-CE19-WZ0xx	Cyan	15	5.50	11.8	16.0	Yes	B
HLMP-CB28-RU0xx	Blue	23	1.50	2.40	4.20	No	A
HLMP-CB29-RU0xx	Blue	23	1.50	2.40	4.20	Yes	B
HLMP-CM28-WZ0xx	Green	23	5.50	9.30	16.0	No	A
HLMP-CM29-WZ0xx	Green	23	5.50	9.30	16.0	Yes	B
HLMP-CE28-VY0xx	Cyan	23	4.20	7.40	12.0	No	A
HLMP-CE29-VY0xx	Cyan	23	4.20	7.40	12.0	Yes	B
HLMP-CB38-QT0xx	Blue	30	1.15	1.50	3.20	No	A
HLMP-CB39-QT0xx	Blue	30	1.15	1.50	3.20	Yes	B
HLMP-CM38-UX0xx	Green	30	3.20	5.00	9.30	No	A
HLMP-CM39-UX0xx	Green	30	3.20	5.00	9.30	Yes	B
HLMP-CE38-TW0xx	Cyan	30	2.50	3.90	7.20	No	A
HLMP-CE39-TW0xx	Cyan	30	2.50	3.90	7.20	Yes	B

### Notes:

1. Tolerance for luminous intensity measurement is  $\pm 15\%$ .
2. The luminous intensity is measured on the mechanical axis of the lamp package.
3. The optical axis is closely aligned with the package mechanical axis.
4. LED light output is bright enough to cause injuries to the eyes. Precautions must be taken to prevent looking directly at the LED with unprotected eyes.

## Ordering Information

**HLMP** - **x** **x** **xx** - **x** **x** **x** **xx**

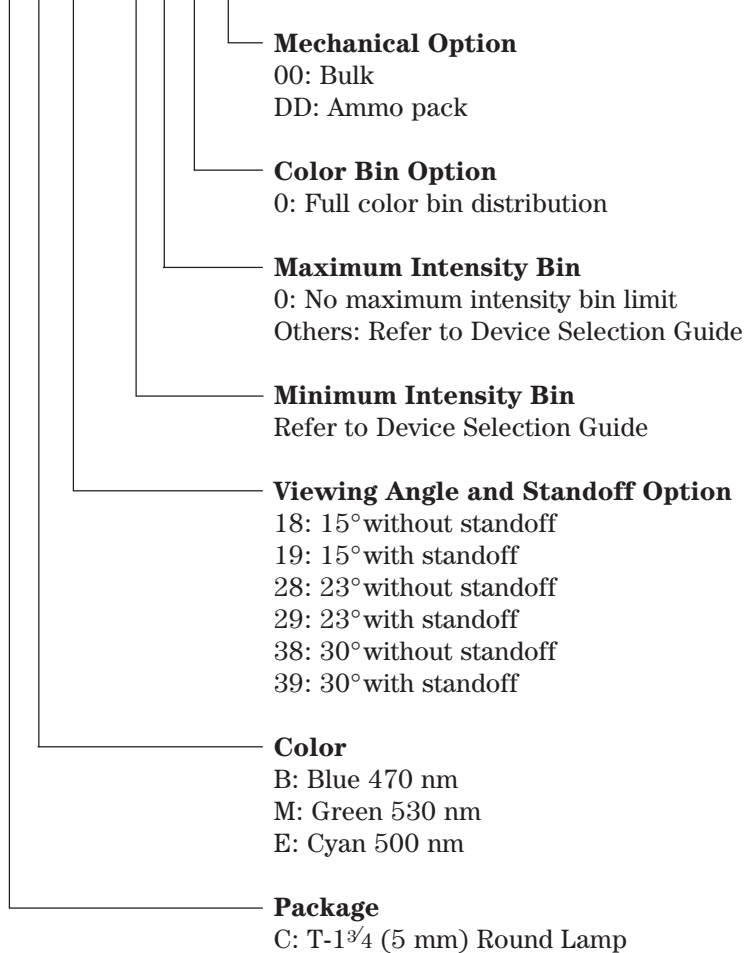

## Absolute Maximum Ratings at T<sub>A</sub> = 25°C

Parameter	Value	Unit
DC Forward Current <sup>[1]</sup>	30	mA
Peak Pulsed Forward Current <sup>[2]</sup>	100	mA
Average Forward Current	30	mA
Power Dissipation	120	mW
LED Junction Temperature	130	°C
Operating Temperature Range	-40 to +85	°C
Storage Temperature Range	-40 to +100	°C
TTW Soldering Temperature <sup>[3]</sup>	250 for 5 secs	°C
Solder Dipping Temperature <sup>[3]</sup>	260 for 5 secs	°C

Notes:

1. Derate linearly as shown in Figure 3.
2. Duty factor 30%, 1KHz.
3. 1.59 mm (0.060 inch) above seating plane.

## Electrical Characteristics at $T_A = 25^\circ\text{C}$

Parameters	Symbol	Blue			Green			Cyan			Units	Test Condition
		Min.	Typ.	Max.	Min.	Typ.	Max.	Min.	Typ.	Max.		
Forward Voltage	$V_F$	3.4	4.0		3.2	4.0		3.3	4.0		V	$I_F = 20\text{ mA}$
Capacitance	C	53			53			53			pF	$V_F = 0, f = 1\text{ MHz}$
Viewing Angle <sup>[1]</sup>												
Cx18/Cx19	$2\theta_{1/2}$	15			15			15			Deg	$I_F = 20\text{ mA}$
Cx28/Cx29		23			23			23				
Cx38/Cx39		30			30			30				
Reverse Voltage <sup>[2]</sup>	$V_R$	0.6			0.6			0.6			V	$I_R = 10\text{ }\mu\text{A}$
Thermal Resistance	$R\theta_{J-PIN}$	240			240			240			$^\circ\text{C/W}$	LED Junction to cathode lead
Dominant Wavelength <sup>[3]</sup>	$\lambda_d$	460	470	480	520	530	540	490	500	510	nm	$I_F = 20\text{ mA}$
Peak Wavelength	$\lambda_{PEAK}$	466			523			495			nm	Peak of wavelength of spectral distribution at $I_F = 20\text{ mA}$
Spectral Half Width	$\Delta\lambda_{1/2}$	21			30			26				Wavelength width at spectral distribution power point at $I_F = 20\text{ mA}$
Luminous Efficacy <sup>[4]</sup>	$\eta_v$	62			588			220			lm/W	Emitted luminous power/Emitted radiant power

### Notes:

1.  $2\theta_{1/2}$  is the off-axis angle where the luminous intensity is  $1/2$  the on axis intensity.
2. The reverse voltage of the product is equivalent to the forward voltage of the protective chip at  $I_R = 10\text{ }\mu\text{A}$ .
3. The dominant wavelength,  $\lambda_d$ , is derived from the Chromaticity Diagram and represents the color of the lamp.
4. The radiant intensity,  $I_e$  in watts/steradian, may be found from the equation  $I_e = I_v/\eta_v$ , where  $I_v$  is the luminous intensity in candelas and  $\eta_v$  is the luminous efficacy in lumens/watt.

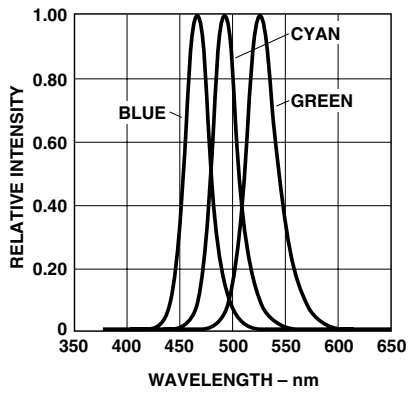

Figure 1. Relative intensity vs. wavelength.

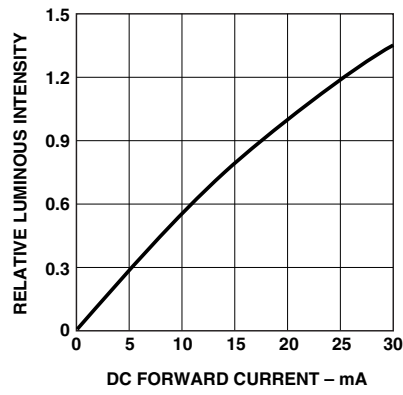

Figure 2. Relative luminous intensity vs. forward current.

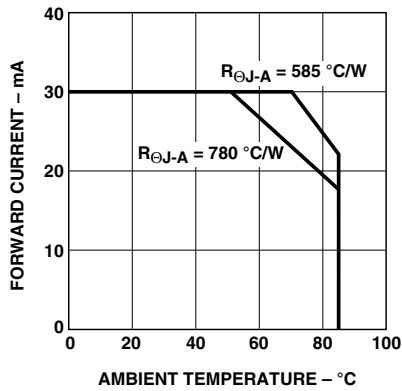

Figure 3. Forward current vs. ambient temperature.

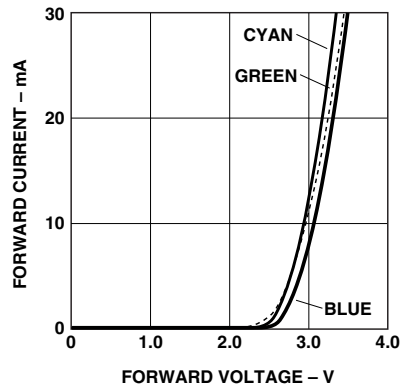

Figure 4. Forward current vs. forward voltage.

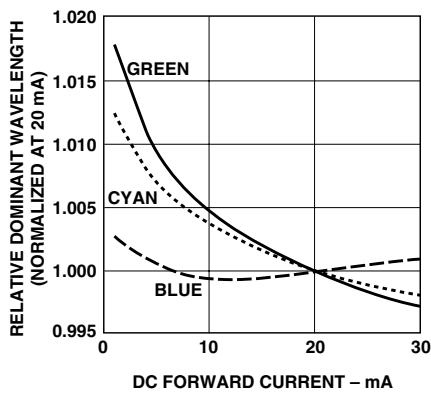

Figure 5. Relative dominant wavelength vs DC forward current.

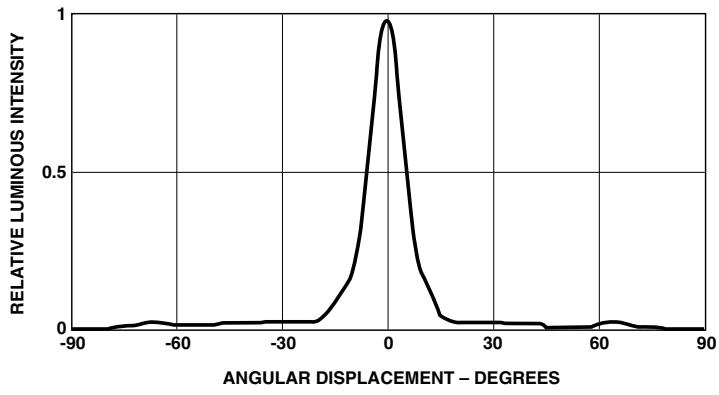

Figure 6. Spatial radiation pattern – 15 degree lamps.

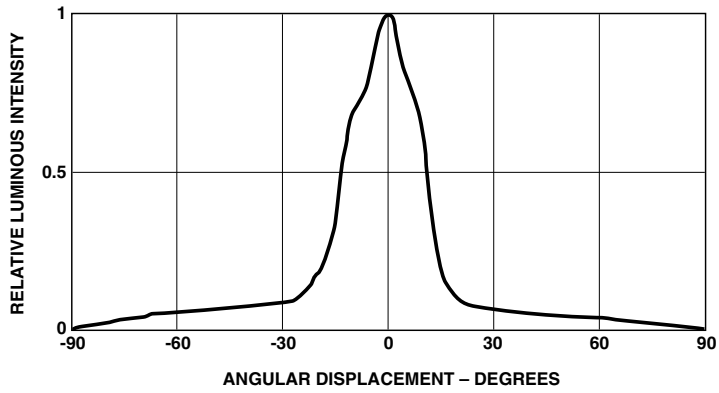

Figure 7. Spatial radiation pattern – 23 degree lamps.

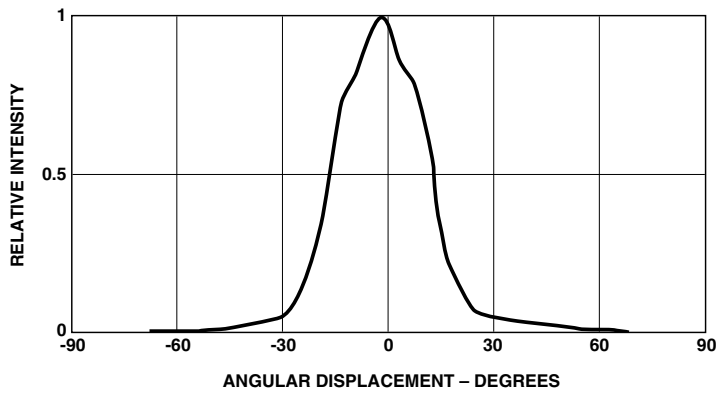

Figure 8. Spatial radiation pattern – 30 degree lamps.

### Intensity Bin Limit Table

Bin	Intensity (mcd) at 20 mA	
	Min	Max
N	680	880
P	880	1150
Q	1150	1500
R	1500	1900
S	1900	2500
T	2500	3200
U	3200	4200
V	4200	5500
W	5500	7200
X	7200	9300
Y	9300	12000
Z	12000	16000
1	16000	21000

Tolerance for each bin limit is  $\pm 15\%$ .

### Blue Color Bin Table

Bin	Min. Dom	Max. Dom	Xmin.	Ymin.	Xmax.	Ymax.
1	460.0	464.0	0.1440	0.0297	0.1766	0.0966
			0.1818	0.0904	0.1374	0.0374
2	464.0	468.0	0.1374	0.0374	0.1699	0.1062
			0.1766	0.0966	0.1291	0.0495
3	468.0	472.0	0.1291	0.0495	0.1616	0.1209
			0.1699	0.1062	0.1187	0.0671
4	472.0	476.0	0.1187	0.0671	0.1517	0.1423
			0.1616	0.1209	0.1063	0.0945
5	476.0	480.0	0.1063	0.0945	0.1397	0.1728
			0.1517	0.1423	0.0913	0.1327

Tolerance for each bin limit is  $\pm 0.5$  nm.

### Green Color Bin Table

Bin	Min. Dom	Max. Dom	Xmin.	Ymin.	Xmax.	Ymax.
1	520.0	524.0	0.0743	0.8338	0.1856	0.6556
			0.1650	0.6586	0.1060	0.8292
2	524.0	528.0	0.1060	0.8292	0.2068	0.6463
			0.1856	0.6556	0.1387	0.8148
3	528.0	532.0	0.1387	0.8148	0.2273	0.6344
			0.2068	0.6463	0.1702	0.7965
4	532.0	536.0	0.1702	0.7965	0.2469	0.6213
			0.2273	0.6344	0.2003	0.7764
5	536.0	540.0	0.2003	0.7764	0.2659	0.6070
			0.2469	0.6213	0.2296	0.7543

Tolerance for each bin limit is  $\pm 0.5$  nm.

### Cyan Color Bin Table

Bin	Min. Dom	Max. Dom	Xmin.	Ymin.	Xmax.	Ymax.
3	500.0	505.0	0.0082	0.5384	0.1027	0.5584
			0.1057	0.4769	0.0039	0.6548
4	505.0	510.0	0.0039	0.6548	0.1097	0.6251
			0.1027	0.5584	0.0139	0.7502
7	498.0	503.0	0.0132	0.4882	0.1028	0.5273
			0.1092	0.4417	0.0040	0.6104
8	503.0	508.0	0.0040	0.6104	0.1056	0.6007
			0.1028	0.5273	0.0080	0.7153

Tolerance for each bin limit is  $\pm 0.5$  nm.



For product information and a complete list of distributors, please go to our website: [www.avagotech.com](http://www.avagotech.com)

Avago, Avago Technologies, and the A logo are trademarks of Avago Technologies Limited in the United States and other countries.  
Data subject to change. Copyright © 2006 Avago Technologies Limited. All rights reserved.  
5988-9268EN May 31, 2006

