

# HITACHI

KAOHSIUNG HITACHI  
ELECTRONICS CO.,LTD  
P.O. BOX 26-27  
2,13TH EAST ST. K.E.P.Z.  
KAOHSIUNG TAIWAN R.O.C.  
TEL:(07) 821-5811(7 LINE)  
FAX:(07) 821-5815

FOR MESSRS : \_\_\_\_\_

DATE : May.13,2008

## CUSTOMER'S ACCEPTANCE SPECIFICATIONS

### TX14D11VM1CBA

#### C O N T E N T S

No.	ITEM	SHEET No.	PAGE
1	COVER	7B64PS 2701-TX14D11VM1CBA-5	1-1/1
2	RECORD OF REVISION	7B64PS 2702-TX14D11VM1CBA-5	2-1/3~3/3
3	GENERAL DATA	7B64PS 2703-TX14D11VM1CBA-5	3-1/1
4	ABSOLUTE MAXIMUM RATINGS	7B64PS 2704-TX14D11VM1CBA-5	4-1/1
5	ELECTRICAL CHARACTERISTICS	7B64PS 2705-TX14D11VM1CBA-5	5-1/1
6	OPTICAL CHARACTERISTICS	7B64PS 2706-TX14D11VM1CBA-5	6-1/3~3/3
7	BLOCK DIAGRAM	7B64PS 2707-TX14D11VM1CBA-5	7-1/1
8	INTERFACE TIMING CHART	7B64PS 2708-TX14D11VM1CBA-5	8-1/5~5/5
9	DIMENSIONAL OUTLINE	7B63PS 2709-TX14D11VM1CBA-5	9-1/2~9-2/2
10	APPEARANCE STANDARD	7B64PS 2710-TX14D11VM1CBA-5	10-1/5~5/5
11	PRECAUTION IN DESIGN	7B64PS 2711-TX14D11VM1CBA-5	11-1/3~3/3
12	DESIGNATION OF LOT MARK	7B64PS 2712-TX14D11VM1CBA-5	12-1/1
13	PRECAUTION FOR USE	7B64PS 2713-TX14D11VM1CBA-5	13-1/1

\*When product will be discontinued, customer will be informed by HITACHI with twelve months prior announcement.

ACCEPTED BY: \_\_\_\_\_

PROPOSED BY: *Dan Cheng*

KAOHSIUNG HITACHI ELECTRONICS CO.,LTD.	Sh. No.	7B64PS 2701-TX14D11VM1CBA-5	PAGE	1-1/1
---	------------	-----------------------------	------	-------

## RECORD OF REVISION

DATE	SHEET No.	SUMMARY																																		
Aug.29,'03	7B64PS 2703-TX14D11VM1CBA-2 PAGE 4-1/1	4.2 GENERAL DATA ADDED : CFL Life Time : 50,000 h (Average) at 25°C , IL=4.0mA max. Note 11 : When brightness reached 50% of initial brightness.																																		
	7B64PS 2705-TX14D11VM1CBA-2 PAGE 5-1/1	5.1 ELECTRICAL CHARACTERISTICS OF LCD <table border="1" style="width: 100%; border-collapse: collapse; margin-bottom: 10px;"> <thead> <tr> <th>ITEM</th> <th>CONDITION</th> <th>MIN.</th> <th>TYP.</th> <th>MAX.</th> </tr> </thead> <tbody> <tr> <td rowspan="2">Input Voltage For Logic (Note1)</td> <td>"H" level</td> <td>2.0</td> <td>-</td> <td>DVDD</td> </tr> <tr> <td>"L" level</td> <td>VSS</td> <td>-</td> <td>0.8</td> </tr> </tbody> </table> <p style="text-align: center;">↓</p> <table border="1" style="width: 100%; border-collapse: collapse;"> <thead> <tr> <th>ITEM</th> <th>CONDITION</th> <th>MIN.</th> <th>TYP.</th> <th>MAX.</th> </tr> </thead> <tbody> <tr> <td rowspan="2">Input Voltage For Logic (Note1)</td> <td>"H" level</td> <td>2.0</td> <td>-</td> <td>VDD</td> </tr> <tr> <td>"L" level</td> <td>VSS</td> <td>-</td> <td>0.8</td> </tr> </tbody> </table>	ITEM	CONDITION	MIN.	TYP.	MAX.	Input Voltage For Logic (Note1)	"H" level	2.0	-	DVDD	"L" level	VSS	-	0.8	ITEM	CONDITION	MIN.	TYP.	MAX.	Input Voltage For Logic (Note1)	"H" level	2.0	-	VDD	"L" level	VSS	-	0.8						
	ITEM	CONDITION	MIN.	TYP.	MAX.																															
Input Voltage For Logic (Note1)	"H" level	2.0	-	DVDD																																
	"L" level	VSS	-	0.8																																
ITEM	CONDITION	MIN.	TYP.	MAX.																																
Input Voltage For Logic (Note1)	"H" level	2.0	-	VDD																																
	"L" level	VSS	-	0.8																																
7B64PS 2707-TX14D11VM1CBA-2 PAGE 7-1/1	7. BLOCK DIAGRAM ADDED : Data / Timing Signals <div style="text-align: center; margin-top: 10px;"> <p style="text-align: center;">I/F(CN1) → Power Supply &amp; Data / Clock Timing Signals</p> </div>																																			
Nov.07,'03	7B64PS 2703-TX14D11VM1CBA-3 PAGE 3-1/1	3. GENERAL DATA (11) weight (175)g → 165g (typ.)																																		
	7B64PS 2706-TX14D11VM1CBA-3 PAGE 6-1/3	6.1 OPTICAL CHARACTERISTICS OF LCD <table border="1" style="width: 100%; border-collapse: collapse; margin-bottom: 10px;"> <thead> <tr> <th>ITEM</th> <th>SYMBOL</th> <th>CONDITION</th> <th>TYP.</th> </tr> </thead> <tbody> <tr> <td rowspan="4">Viewing Area</td> <td><math>\theta x</math></td> <td><math>\phi = 0^\circ, K \geq 5.0</math></td> <td>(50)</td> </tr> <tr> <td><math>\theta x'</math></td> <td><math>\phi = 180^\circ, K \geq 5.0</math></td> <td>(50)</td> </tr> <tr> <td><math>\theta y</math></td> <td><math>\phi = 90^\circ, K \geq 5.0</math></td> <td>(40)</td> </tr> <tr> <td><math>\theta y</math></td> <td><math>\phi = 270^\circ, K \geq 5.0</math></td> <td>(80)</td> </tr> </tbody> </table> <p style="text-align: center;">↓</p> <table border="1" style="width: 100%; border-collapse: collapse;"> <thead> <tr> <th>ITEM</th> <th>SYMBOL</th> <th>CONDITION</th> <th>TYP.</th> </tr> </thead> <tbody> <tr> <td rowspan="4">Viewing Area</td> <td><math>\theta x</math></td> <td><math>\phi = 0^\circ, K \geq 5.0</math></td> <td>65</td> </tr> <tr> <td><math>\theta x'</math></td> <td><math>\phi = 180^\circ, K \geq 5.0</math></td> <td>65</td> </tr> <tr> <td><math>\theta y</math></td> <td><math>\phi = 90^\circ, K \geq 5.0</math></td> <td>70</td> </tr> <tr> <td><math>\theta y</math></td> <td><math>\phi = 270^\circ, K \geq 5.0</math></td> <td>50</td> </tr> </tbody> </table>	ITEM	SYMBOL	CONDITION	TYP.	Viewing Area	$\theta x$	$\phi = 0^\circ, K \geq 5.0$	(50)	$\theta x'$	$\phi = 180^\circ, K \geq 5.0$	(50)	$\theta y$	$\phi = 90^\circ, K \geq 5.0$	(40)	$\theta y$	$\phi = 270^\circ, K \geq 5.0$	(80)	ITEM	SYMBOL	CONDITION	TYP.	Viewing Area	$\theta x$	$\phi = 0^\circ, K \geq 5.0$	65	$\theta x'$	$\phi = 180^\circ, K \geq 5.0$	65	$\theta y$	$\phi = 90^\circ, K \geq 5.0$	70	$\theta y$	$\phi = 270^\circ, K \geq 5.0$	50
	ITEM	SYMBOL	CONDITION	TYP.																																
Viewing Area	$\theta x$	$\phi = 0^\circ, K \geq 5.0$	(50)																																	
	$\theta x'$	$\phi = 180^\circ, K \geq 5.0$	(50)																																	
	$\theta y$	$\phi = 90^\circ, K \geq 5.0$	(40)																																	
	$\theta y$	$\phi = 270^\circ, K \geq 5.0$	(80)																																	
ITEM	SYMBOL	CONDITION	TYP.																																	
Viewing Area	$\theta x$	$\phi = 0^\circ, K \geq 5.0$	65																																	
	$\theta x'$	$\phi = 180^\circ, K \geq 5.0$	65																																	
	$\theta y$	$\phi = 90^\circ, K \geq 5.0$	70																																	
	$\theta y$	$\phi = 270^\circ, K \geq 5.0$	50																																	
7B64PS 2708-TX14D11VM1CBA-3 PAGE 8-5/5	8.5 INTERNAC PIN CONNECTION CORRECTED CN1 JAE : FA5B040HP1 → FA5B040HF1																																			

## RECORD OF REVISION

DATE	SHEET No.	SUMMARY																																
Nov.07,'03	7B64PS 2709- TX14D11VM1CBA-3 PAGE 9-2/2	9. DIMENSIONAL OUT LINE CORRECTED : The dimension of CN1 21.25 → (17.35)																																
May.18.'04	7B64PS 2704- TX14D11VM1CBA-4 PAGE 4-1/1	4.2 ENVIRONMENTAL ABSOLUTE MAXIMUM RATINGS <table border="1" style="width: 100%; margin-top: 10px;"> <thead> <tr> <th rowspan="2">I T E M</th> <th colspan="2">OPERATING</th> <th colspan="2">STORAGE</th> <th rowspan="2">COMMENT</th> </tr> <tr> <th>MIN.</th> <th>MAX.</th> <th>MIN.</th> <th>MAX.</th> </tr> </thead> <tbody> <tr> <td>Temperature</td> <td>-10</td> <td>70</td> <td>-30</td> <td>80</td> <td>(Note 2,3,6,7,8,10)</td> </tr> </tbody> </table> <p style="text-align: center;">↓</p> <table border="1" style="width: 100%; margin-top: 10px;"> <thead> <tr> <th rowspan="2">I T E M</th> <th colspan="2">OPERATING</th> <th colspan="2">STORAGE</th> <th rowspan="2">COMMENT</th> </tr> <tr> <th>MIN.</th> <th>MAX.</th> <th>MIN.</th> <th>MAX.</th> </tr> </thead> <tbody> <tr> <td>Temperature</td> <td>-20</td> <td>70</td> <td>-30</td> <td>80</td> <td>(Note 2,3,6,7,8,10,12)</td> </tr> </tbody> </table> <p>Note 2 : Ta at -30°C for 48h , at 80°C for 100h.</p> <p style="text-align: center;">↓</p> <p>Note 2 : For storage condition Ta at -30°C &lt; 48h , at 80°C &lt; 100h. For operating condition Ta at -20°C &lt; 100h</p> <p>Addendum :</p> <p>Note 12 : When LCM be operated less than 0°C , the lift time of CFL will be reduced . The rise time of CFL ON will be longer when the ambient temperature below 0°C and confirming the characteristics of inverter is necessary .</p>	I T E M	OPERATING		STORAGE		COMMENT	MIN.	MAX.	MIN.	MAX.	Temperature	-10	70	-30	80	(Note 2,3,6,7,8,10)	I T E M	OPERATING		STORAGE		COMMENT	MIN.	MAX.	MIN.	MAX.	Temperature	-20	70	-30	80	(Note 2,3,6,7,8,10,12)
	I T E M	OPERATING		STORAGE		COMMENT																												
MIN.		MAX.	MIN.	MAX.																														
Temperature	-10	70	-30	80	(Note 2,3,6,7,8,10)																													
I T E M	OPERATING		STORAGE		COMMENT																													
	MIN.	MAX.	MIN.	MAX.																														
Temperature	-20	70	-30	80	(Note 2,3,6,7,8,10,12)																													
	7B64PS 2706- TX14D11VM1CBA-4 PAGE 6-1/3	6.1 OPTICAL CHARACTERISTICS OF LCD <table border="1" style="width: 100%; margin-top: 10px;"> <thead> <tr> <th colspan="2">ITEM</th> <th>SYMBOL</th> <th>MIN.</th> </tr> </thead> <tbody> <tr> <td>Color Tone (Primary Color)</td> <td>Red</td> <td>x</td> <td>0.61</td> </tr> </tbody> </table> <p style="text-align: center;">↓</p> <table border="1" style="width: 100%; margin-top: 10px;"> <thead> <tr> <th colspan="2">ITEM</th> <th>SYMBOL</th> <th>MIN.</th> </tr> </thead> <tbody> <tr> <td>Color Tone (Primary Color)</td> <td>Red</td> <td>x</td> <td>0.56</td> </tr> </tbody> </table>	ITEM		SYMBOL	MIN.	Color Tone (Primary Color)	Red	x	0.61	ITEM		SYMBOL	MIN.	Color Tone (Primary Color)	Red	x	0.56																
ITEM		SYMBOL	MIN.																															
Color Tone (Primary Color)	Red	x	0.61																															
ITEM		SYMBOL	MIN.																															
Color Tone (Primary Color)	Red	x	0.56																															
May.13,'08	7B64PS 2708- TX14D11VM1CBA-5 PAGE 8-5/5	8.5 INTERNAL PIN CONNECTION Changed : CN1 JAE : FA5B040HF1(Sn plating) → FA5B040HP1R3000(Au plating)																																
	7B64PS 2709- TX14D11VM1CBA-5 PAGE 9-2/2	9. DIMENSIONAL OUTLINE The lot label size and position is changed.																																

## RECORD OF REVISION

DATE	SHEET No.	SUMMARY						
May.13,'08	7B64PS 2712- TX14D11VM1CBA-5 PAGE 12-1/1	<p>12.1 LOT MARK</p> <p>Changed : 5 digits for production number ↓ 6 digits for production number</p> <p>12.3 LOCATION OF LOT MARK</p> <p>Changed:</p> <div style="text-align: center;"> </div> <p>Added : 12.4 REVISION(Rev.) CONTROL</p> <table border="1" style="margin-left: auto; margin-right: auto; border-collapse: collapse;"> <thead> <tr> <th style="width: 15%;">Rev No.</th> <th style="width: 85%;">ITEM</th> </tr> </thead> <tbody> <tr> <td style="text-align: center;">-</td> <td>CN1 JAE : FA5B040HF1</td> </tr> <tr> <td style="text-align: center;">A</td> <td>CN1 JAE : FA5B040HP1R3000</td> </tr> </tbody> </table>	Rev No.	ITEM	-	CN1 JAE : FA5B040HF1	A	CN1 JAE : FA5B040HP1R3000
Rev No.	ITEM							
-	CN1 JAE : FA5B040HF1							
A	CN1 JAE : FA5B040HP1R3000							

### 3.GENERAL DATA

(1) Part Name	TX14D11VM1CBA
(2) Module Dimensions	167.0(W)mm x 109.0(H)mm x (9.2)max.(D)mm
(3) LCD Active Area	115.2(W)mm x 86.4(H)mm
(4) Dot Pitch	0.12(W)mm x 3(R,G,B)(W) x 0.36(H)mm
(5) Resolution	320x3(R,G,B)(W)x240(H) dots
(6) Color Pixel Arrangement	R,G,B Vertical stripe
(7) LCD Type	Transmissive Color TFT LCD (Normally White)
(8) Display Type	Active Matrix
(9) Number of Colors	262k Colors (R,G,B 6bit parallel)
(10) Backlight	Cold Cathode Fluorescent Tube (U type CFL) x 1
(11) Weight	165g (typ.)
(12) Interface	40pin (C-MOS)
(13) Power Supply Voltage	3.3V only (Include Timing Controller and Power Unit)
(14) Viewing Direction	6 O'clock

#### 4. ABSOLUTE MAXIMUM RATINGS

##### 4.1 ELECTRICAL ABSOLUTE MAXIMUM RATINGS OF LCD

VSS=0V

ITEM	SYMBOL	MIN.	MAX.	UNIT	COMMENT
Power Supply for Logic	VDD	-0.3	4.0	V	
Input Voltage	VI	-0.2	VDD+0.2		(Note 1)
Input Current	II	0	1	A	
Static Electricity	VESD0	-	±100	V	(Note 2,3)
	VESD1	-	±8	kV	(Note 2,4)

Note 1 : DTMG,DCLK,RD0~RD5,GD0~GD5,BD0~BD5.

Note 2 : 200pF-250Ω 25°C - 70%RH

Note 3 : Interface Pin Connector.

Note 4 : The surface of metal bezel and LCD panel .

##### 4.2 ENVIRONMENTAL ABSOLUTE MAXIMUM RATINGS

I T E M	OPERATING		STORAGE		COMMENT
	MIN.	MAX.	MIN.	MAX.	
Temperature	-20	70	-30	80	(Note 2,3,6,7,8,10,12)
Humidity	(Note 1)		(Note 1)		Without condensation
Vibration	-	4.9m/s <sup>2</sup> (0.5G)	-	19.6m/s <sup>2</sup> (2G) (Note 5)	(Note 4)
Shock	-	29.4m/s <sup>2</sup> (3G)	-	490m/s <sup>2</sup> (50G) (Note 5)	XYZ directions (Note 9)
Corrosive Gas	Not Acceptable		Not Acceptable		
CFL Life Time	50,000 h (Average) (Note 11)		-		At 25°C , IL=4.0mA max.

Note 1 : Ta ≤ 40°C :85%RH max.

Ta > 40°C :Absolute humidity must be lower than the humidity of 85%RH at 40°C .

Note 2 : For storage condition Ta at -30°C < 48h , at 80°C < 100h.

For operating condition Ta at -20°C < 100h

Note 3 : Background color changes slightly depending on ambient temperature.

This phenomenon is reversible.

Note 4 : 5Hz~100Hz(Except resonance frequency)

Note 5 : This LCM will resume normal operation after finishing the test.

Note 6 : The response time will be slower as low temperature.

Note 7 : Only operation is guaranteed at operating temperature. Contrast, response time, another display quality are evaluated at +25°C.

Note 8 : When LCM is operated over 60°C ambient temperature , the ICFL of LCM should be adjusted to 3mA max.

Note 9 : Pulse Width : 10ms

Note 10 : This is panel surface temperature , not ambient temperature.

Note 11 : When brightness reached 50% of initial brightness.

Note 12 : When LCM be operated less than 0°C , the lift time of CFL will be reduced .

The rise time of CFL ON will be longer when the ambient temperature below 0°C and confirming the characteristics of inverter is necessary .

KAOSIUNG HITACHI ELECTRONICS CO.,LTD.	DATE	May.13,'08	Sh. No.	7B64PS 2704-TX14D11VM1CBA-5	PAGE	4-1/1
--	------	------------	------------	-----------------------------	------	-------

## 5. ELECTRICAL CHARACTERISTICS

### 5.1 ELECTRICAL CHARACTERISTICS OF LCD

Ta=25°C, VSS=0V

ITEM	SYMBOL	CONDITION	MIN.	TYP.	MAX.	UNIT
Power Supply Voltage	VDD	-	3.0	3.3	3.6	V
Input Voltage for Logic (Note 1)	VI	"H" level	2.0	-	VDD	V
		"L" level	VSS	-	0.8	
Power Supply Current (Note 2)	IDD	VDD-VSS=3.3V	-	150	-	mA
Vsync Frequency	fV	-	52	60	68	Hz
Hsync Frequency	fH	-	13.1	15.2	17.7	kHz
DCLK Frequency	fCLK	-	4.85	5.85	7.0	MHz

Note 1 : DTMG, DCLK, RD0~RD5, GD0~GD5, BD0~BD5.

Note 2 : fV=60Hz, Ta=25°C, Pattern used as display pattern : All Black.

Note 3 : Need to make sure of flickering and rippling of display when setting the frame frequency in your set.

### 5.2 ELECTRICAL CHARACTERISTICS OF BACKLIGHT

ITEM	SYMBOL	MIN.	TYP.	MAX.	UNIT	NOTE
Lamp Voltage	VL	-	760	-	Vrms	Ta=25°C
Frequency	fL	-	55	-	kHz	
Lamp Current (1Lamp)(Note 6)	IL	3.0	4.0	6.0	mA	Ta=25°C
Starting Discharge Voltage	VS (Note 2)	1300	-	-	Vrms	Ta=5°C

Note 1 : Please design your lamp driving circuit (inverter) according to the above specifications, and inform HITACHI about it.

Note 2 : Starting discharge voltage is increased when LCM is operating under low temperature.

Please check the characteristics of your inverter before applying to your set.

Note 3 : Average life time of CFL will be decreased when LCM is operating under low temperature.

Note 4 : Under lower driving frequency of an inverter, a certain Backlight system (CFL & CFL reflection sheet) may generate a sound noise. Before designing the inverter, please consider the driving frequency and noise.

Note 5 : When IL is over 6.0mA, it may cause uneven contrast near CFL location, due to heat dispersion form CFL.

Note 6 : We recommend to equip protection circuit (To stop output) which works under abnormal operation to the inverter for CFL

## 6. OPTICAL CHARACTERISTICS

### 6.1 OPTICAL CHARACTERISTICS OF LCD

Ta=25°C (Backlight on)

ITEM	SYMBOL	CONDITION	MIN.	TYP.	MAX.	UNIT	NOTE
Viewing Area	$\theta x$	$\phi=0^\circ, K \geq 10.0$	50	60	-	deg	1~5
	$\theta x'$	$\phi=180^\circ, K \geq 10.0$	50	60	-	deg	1~5
	$\theta y$	$\phi=90^\circ, K \geq 10.0$	65	75	-	deg	1~5
	$\theta y'$	$\phi=270^\circ, K \geq 10.0$	45	55	-	deg	1~5
Contrast Ratio	K	$\phi=0^\circ, \theta=0^\circ$	120	350	-	-	5
Response Time (rise+fall)	tr+tf	$\phi=0^\circ, \theta=0^\circ$	-	(45)	-	ms	6
Color Tone (Primary Color)	Red	x	$\phi=0^\circ, \theta=0^\circ$	0.56	0.61	0.66	-
		y		0.28	0.33	0.38	-
	Green	x		0.25	0.30	0.35	-
		y		0.52	0.57	0.62	-
	Blue	x		0.09	0.14	0.19	-
		y		0.03	0.08	0.13	-
	White	x		0.24	0.29	0.34	-
		y		0.24	0.29	0.34	-

(Measurement condition : HITACHI standard)  
(Note 3~6) : See next page.

#### Note 1 : Driving Condition

Display Pattern : White Raster  
ICFL Current : (4)mA

#### Note 2 : Measurement Condition (Transmittance)

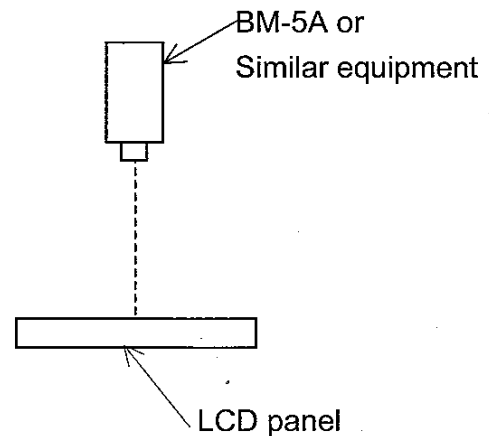



Note 3 : Definition of  $\theta$  and  $\phi$   
(Normal)  
Viewing direction

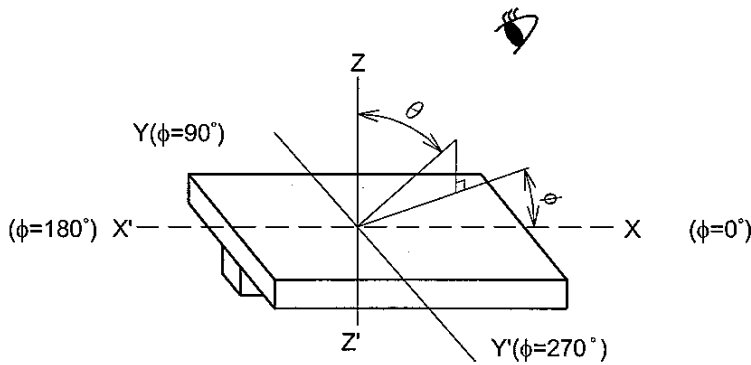

Note 5 : Definition of contrast "K"

$$K = \frac{\text{White Brightness}}{\text{Black Brightness}}$$

Note 4 : Definition of Viewing angle  $\phi_1$  and  $\phi_2$

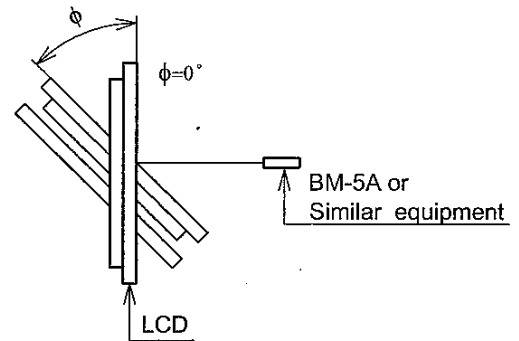
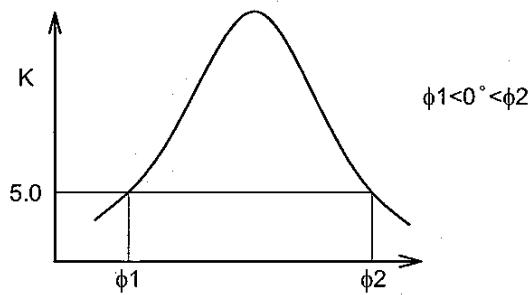

Contrast ratio "K" vs Viewing angle " $\phi$ "

Note 6 : Definition optical response time

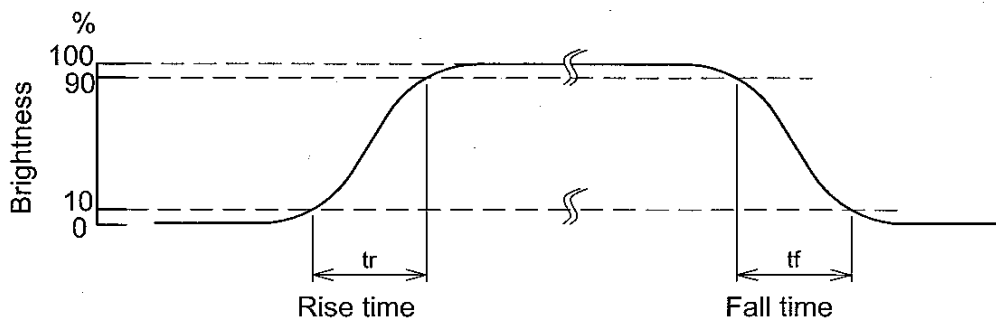
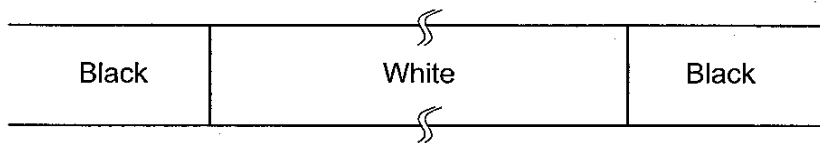

## 6.2 OPTICAL CHARACTERISTICS OF BACKLIGHT

ITEM	MIN.	TYP.	MAX.	UNIT	NOTE
Brightness	200	350	-	cd/m <sup>2</sup>	IL=4.0mA (Note 1,2)
Rise Time	-	3	-	Minute	IL=4.0mA Brightness 80%
Brightness Uniformity	-	-	±25	%	Under mentioned (Note 1,3)

(Measurement condition : HITACHI standard)

CFL:0h operation, Ta=25°C

Display data should all be "ON"

Note 1 : Measurement after 10 minutes from CFL operating.

Average value of 9 points (Note 3)

Note 2 : Brightness control : 100%.

Note 3 : Measurement of the following 9 places on the display.

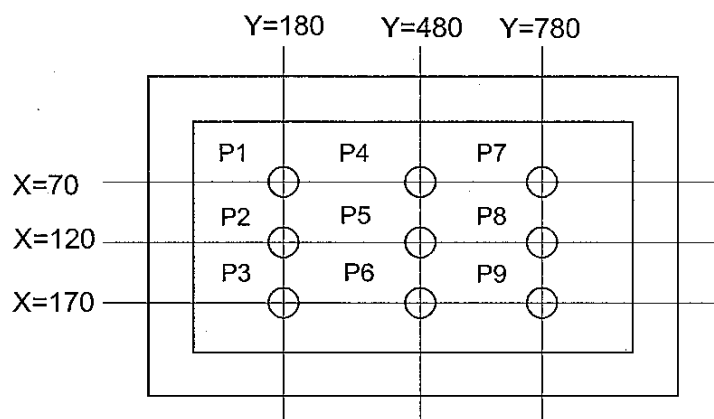

Note 4 : Definition of the brightness tolerance.

$$\left( \frac{\text{Max. brightness or Min. brightness} - \text{Average brightness}}{\text{Average brightness}} \right) \times 100$$

# 7.BLOCK DIAGRAM

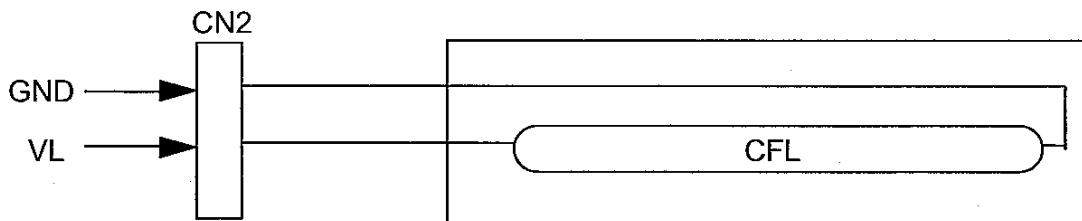
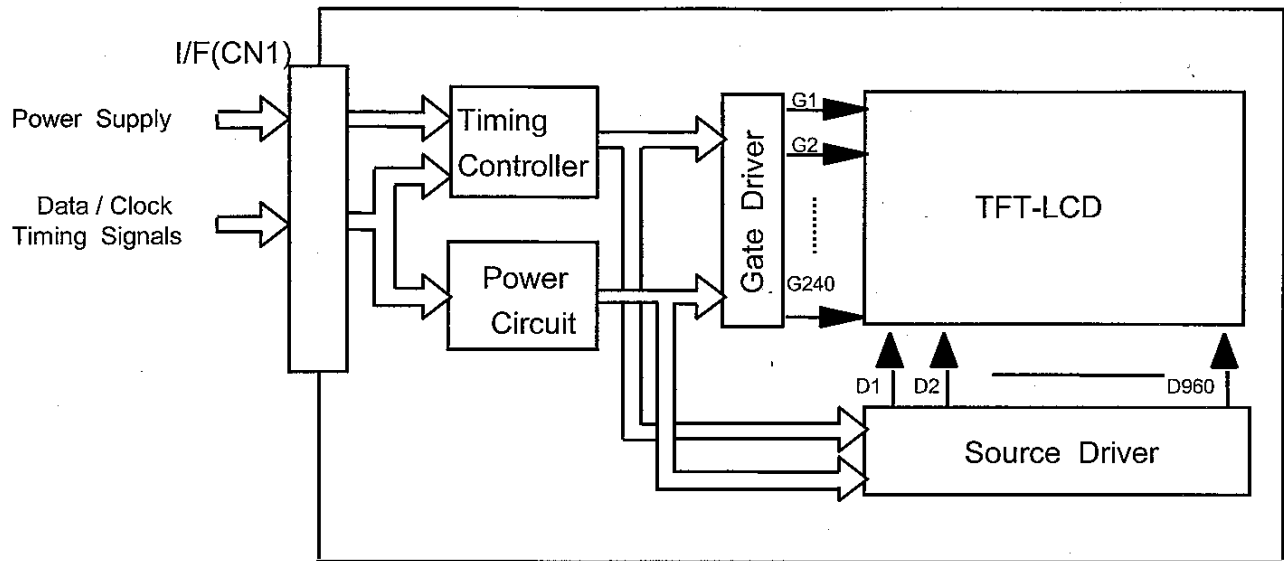

8.INTERFACE TIMING  
8.1 INTERFACE TIMING

ITEM		MIN.	TYP.	MAX.	UNIT	SYMBOL	REMARKS
DCLK	Cycle time	(142)	(171)	(206)	ns	tCLK	
	Low level Width	12	-	-		twCL	
	High level Width	12	-	-		twCH	
	Rise time	-	-	25		trCLK	
	Fall time	-	-	25		tfCLK	
	Duty	0.45	0.5	0.55	-	D	
Hsync	Set up time	5	-	-	ns	tSH	for DCLK
	Hold time	10	-	-		tHH	
	Cycle	370	(385)	397	tCLK	tHP	
	Valid width	4	(5)	-	tWH		
	Rise/Fall time	-	-	30	ns	T <sub>Tr,tFf</sub>	
Vsync	Set up	0	-	-	tCLK	tSV	for Hsync
	Hold	2	-	-		tHV	
	Cycle	251	(253)	261	tHP	tVP	
	Valid width	2	(2)	-		tWV	
	Rise/Fall time	-	-	50	ns	t <sub>v,r,tv</sub>	
DTMG	Set up time	5	-	-	ns	tSI	for DCLK
	Hold time	10	-	-		tHI	
	Rise/Fall time	-	-	30	ns	T <sub>Tr,tFf</sub>	
	Horizontal back porch	28	(35)	-	tCLK	tHBP	
	Horizontal front porch	22	(30)	-		tHFP	
	Vertical back porch	6	(7)	-	tHP	tVBP	
	Vertical front porch	5	(6)	-		tVFP	
Data	Set up time	5	-	-	ns	tSD	for DCLK
	Hold time	10	-	-		tHD	
	Rise/Fall time	-	-	25	ns	T <sub>Dr,tDf</sub>	

Note : Vsync Cycle No. should be set to odd.

## 8.2 Timing Chart

(Data is latched negative edge trigger of DCLK)

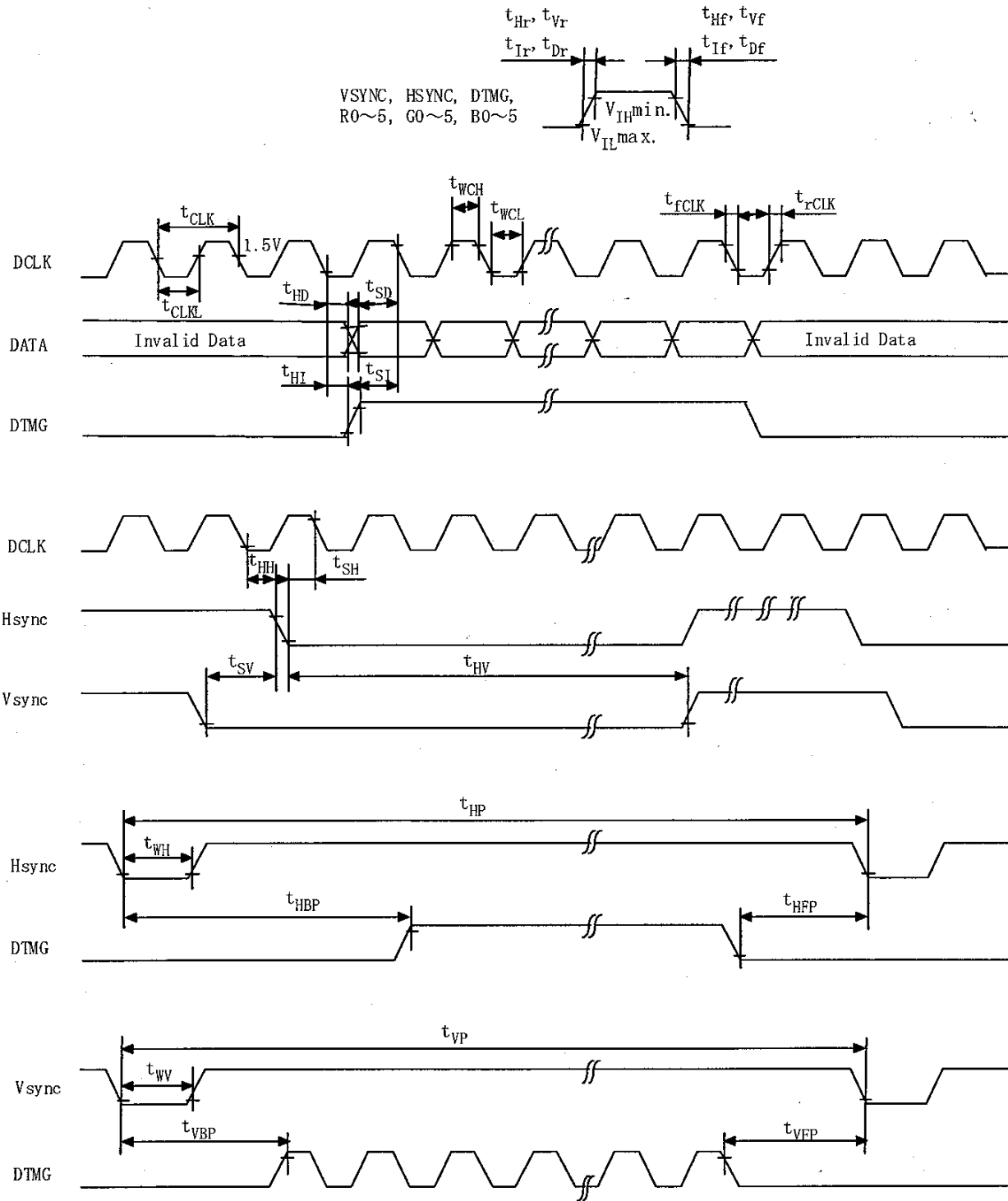

Note 1 : DTMG is definition of the above timing for Hsync and Vsync.

Note 2 : No matter when Hsync and Vsync is inputted ,this LCM can be drove only DTMG Signal. DTMG should be set to low level when it is not input valid data.

### 8.3 POWER ON/OFF SEQUENCE

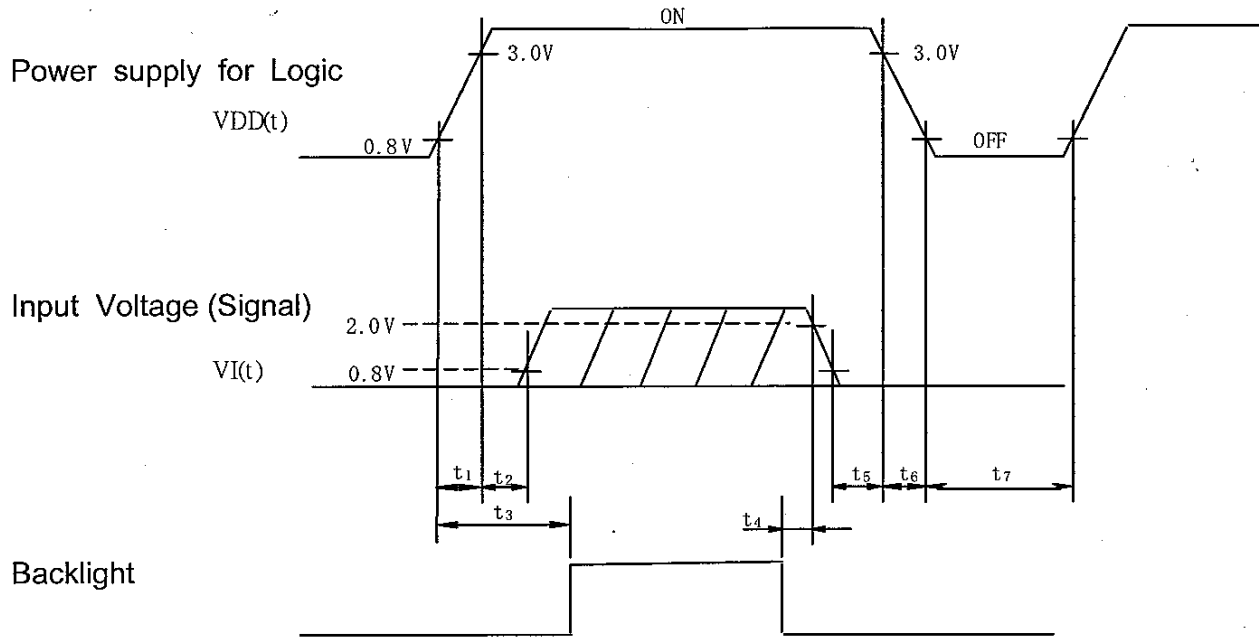

**POWER ON**

- $t_1 \leq 15\text{ms}$
- $0\text{ms} < t_2 \leq 45\text{ms}$
- $0.1\text{s} \leq t_3$

**POWER OFF**

- $5\text{ms} \leq t_4$
- $0\text{ms} \leq t_5 \leq 45\text{ms}$
- $0\text{ms} \leq t_6 \leq 20\text{ms}$
- $0.4\text{s} \leq t_7$

Note 1 :  $0\text{V} \leq \text{VI}(t) \leq \text{VDD}(t)$

VI(t) and VDD(t) is a surfeit of condition for power on/off.

Note 2 : Input Voltage(Signal) should not be set high impedance when power on.

### 8.4 RELATIONSHIP BETWEEN DISPLAYED COLOR AND INPUT DATA

	COLOR & GRAY SCALE	GRAY SCALE LEVELS	DATA SIGNAL																	
			R0	R1	R2	R3	R4	R5	G0	G1	G2	G3	G4	G5	B0	B1	B2	B3	B4	B5
Basic Color	Black	-	0	0	0	0	0	0	0	0	0	0	0	0	0	0	0	0	0	0
	Blue	-	0	0	0	0	0	0	0	0	0	0	0	0	1	1	1	1	1	1
	Green	-	0	0	0	0	0	0	1	1	1	1	1	1	0	0	0	0	0	0
	Cyan	-	0	0	0	0	0	0	1	1	1	1	1	1	1	1	1	1	1	1
	Red	-	1	1	1	1	1	1	0	0	0	0	0	0	0	0	0	0	0	0
	Magenta	-	1	1	1	1	1	1	0	0	0	0	0	0	1	1	1	1	1	1
	Yellow	-	1	1	1	1	1	1	1	1	1	1	1	1	0	0	0	0	0	0
	White	-	1	1	1	1	1	1	1	1	1	1	1	1	1	1	1	1	1	1
Red	Black	GS0	0	0	0	0	0	0	0	0	0	0	0	0	0	0	0	0	0	0
	↑ Darker	GS1	1	1	0	0	0	0	0	0	0	0	0	0	0	0	0	0	0	0
		GS2	0	1	0	0	0	0	0	0	0	0	0	0	0	0	0	0	0	0
	↕																			
	↕																			
	↕																			
	↕																			
	↕																			
Green	Black	GS0	0	0	0	0	0	0	0	0	0	0	0	0	0	0	0	0	0	0
	↑ Darker	GS1	0	0	0	0	0	0	1	0	0	0	0	0	0	0	0	0	0	0
		GS2	0	0	0	0	0	0	0	1	0	0	0	0	0	0	0	0	0	0
	↕																			
	↕																			
	↕																			
	↕																			
	↕																			
Blue	Black	GS0	0	0	0	0	0	0	0	0	0	0	0	0	0	0	0	0	0	0
	↑ Darker	GS1	0	0	0	0	0	0	0	0	0	0	0	0	1	0	0	0	0	0
		GS2	0	0	0	0	0	0	0	0	0	0	0	0	0	1	0	0	0	0
	↕																			
	↕																			
	↕																			
	↕																			
	↕																			
Blue	Brighter	GS61	0	0	0	0	0	0	0	0	0	0	0	0	1	0	1	1	1	1
		GS62	0	0	0	0	0	0	0	0	0	0	0	0	0	1	1	1	1	1
	↕																			
Blue	GS63	0	0	0	0	0	0	0	0	0	0	0	0	1	1	1	1	1	1	

### 8.5 INTERNAL PIN CONNECTION

CN1 JAE : FA5B040HP1R3000(Au plating) (Suitable FPC : t0.3±0.03mm , 0.5±0.03mm pitch)

PIN No.	SIGNAL	FUNCTION
1	VDD	Power Supply for Logic
2	VDD	Power Supply for Logic
3	VDD	Power Supply for Logic
4	VDD	Power Supply for Logic
5	NC	No Connection
6	DTMG	Timing Signal for Data
7	VSS	GND
8	DCLK	Dot Clock
9	VSS	GND
10	NC	No Connection
11	VSS	GND
12	B5	Blue Data
13	B4	
14	B3	
15	VSS	GND
16	B2	Blue Data
17	B1	
18	B0	
19	VSS	GND
20	G5	Green Data
21	G4	
22	G3	
23	VSS	GND
24	G2	Green Data
25	G1	
26	G0	
27	VSS	GND
28	R5	Red Data
29	R4	
30	R3	
31	VSS	GND
32	R2	Red Data
33	R1	
34	R0	
35	(IC)	No Connection
36	VSS	GND
37	NC	No Connection
38	NC	No Connection
39	NC	No Connection
40	NC	No Connection

CN2 JST Housing : BHR-03VS-1

PIN No.	SIGNAL	LEVEL	FUNCTION
1	VCFL	-	Power Supply for CFL
2	NC	-	No connection
3	VSS	-	GND for CFL



### 9. DIMENSIONAL OUTLINE

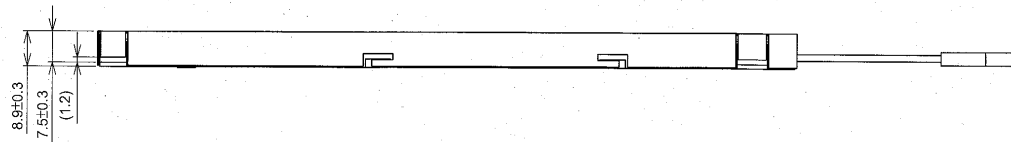
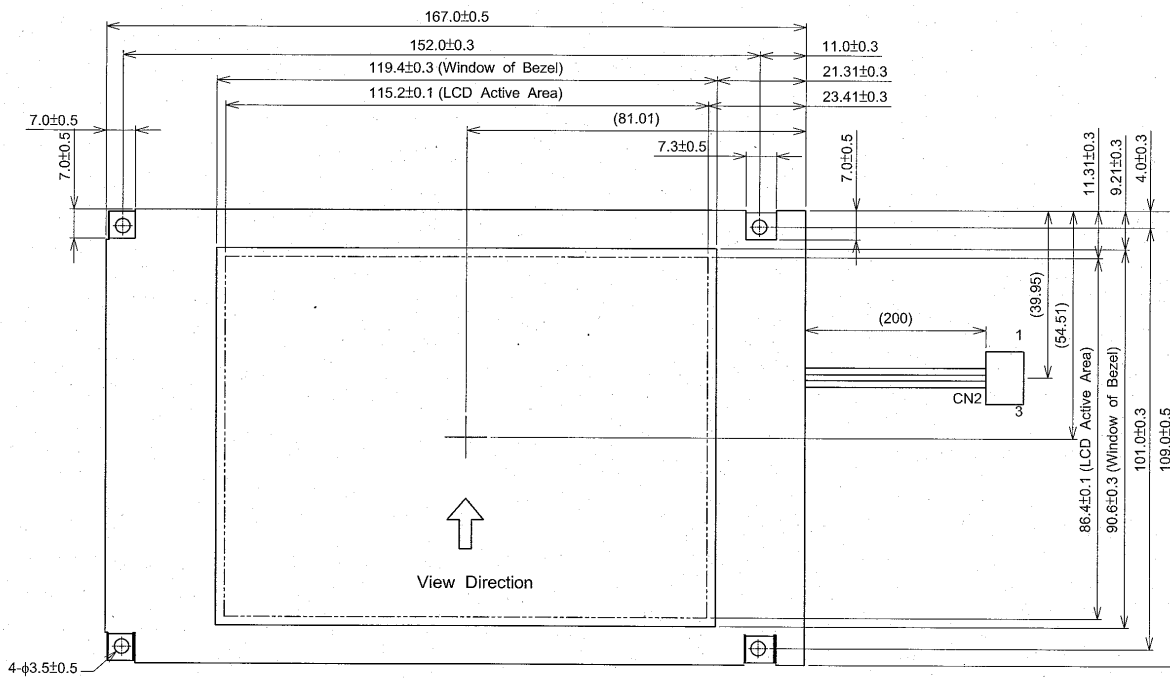

Scale : NTS  
Unit : mm

KAOSIUNG HITACHI ELECTRONICS CO.,LTD.	DATE	May.13,'08	Sh. No.	7B63PS 2709-TX14D11VM1CBA-5	PAGE	9-1/2
--	------	------------	------------	-----------------------------	------	-------

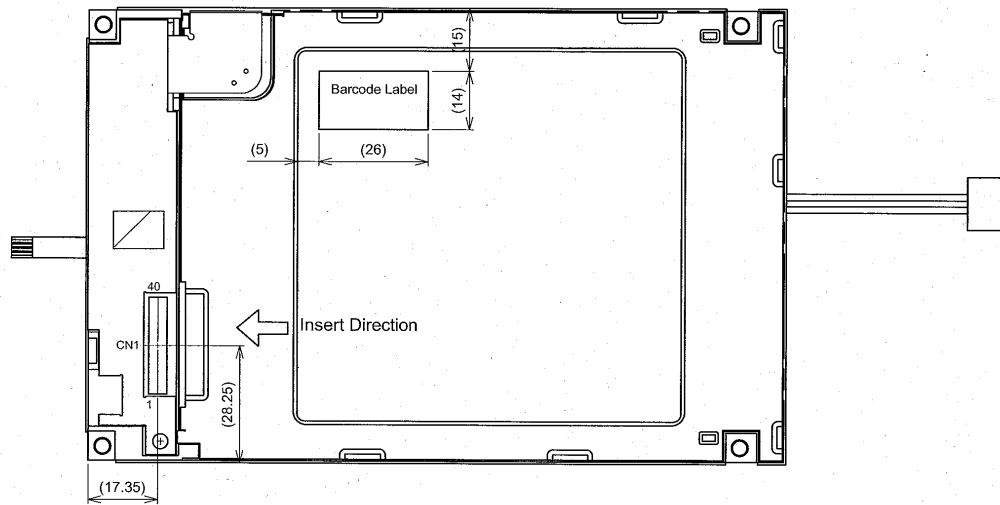

Scale : NTS  
Unit : mm

KAOSIUNG HITACHI ELECTRONICS CO.,LTD.	DATE	May.13,'08	Sh. No.	7B63PS 2709-TX14D11VM1CBA-5	PAGE	9-2/2
--	------	------------	------------	-----------------------------	------	-------

## 10. APPEARANCE STANDARD

### 10.1 APPEARANCE INSPECTION CONDITION

Visual inspection should be done under the following condition.

- (1) The inspection should be done in a dark room.(More than 1000(lx) and non-directive)
- (2) The distance between eyes of an inspector and the LCD module is 30cm.
- (3) The viewing zone is shown the figure.

The  $\theta$  is defined as  $\theta \leq 45^\circ$  for LCM power off

$\theta \leq 5^\circ$  for LCM power on

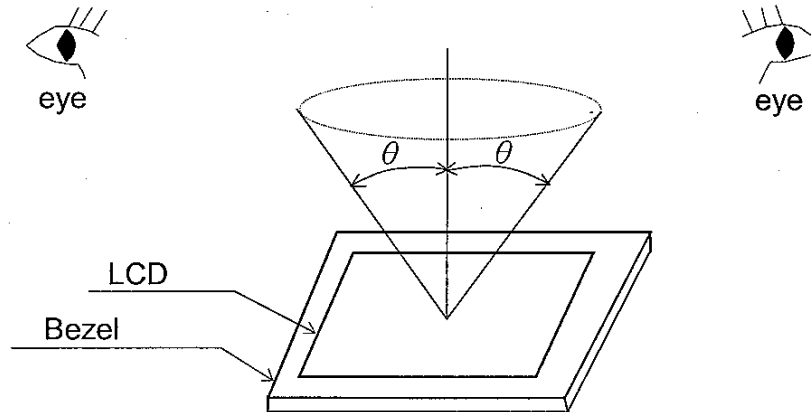

### 10.2 DEFINITION OF ZONE

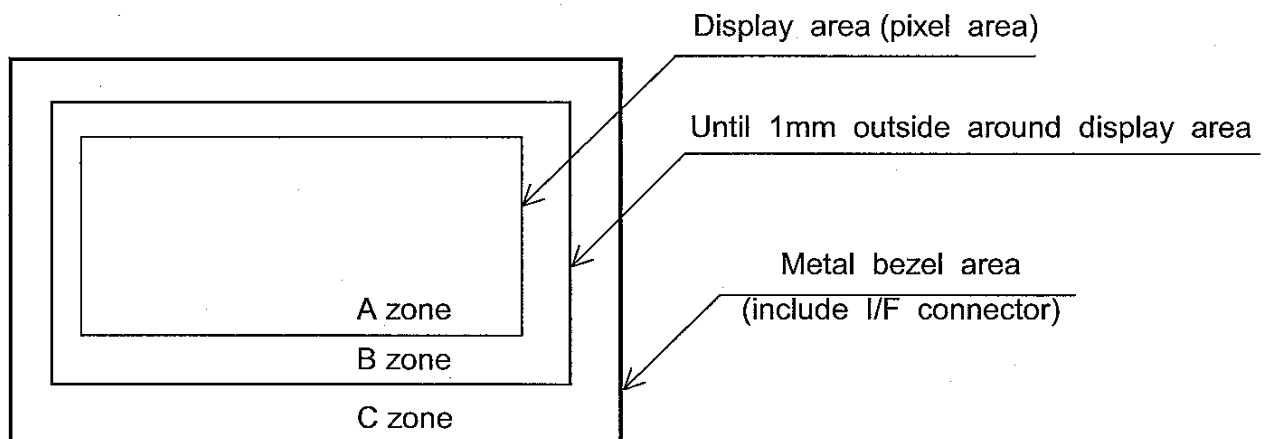

### 10.3 APPEARANCE SPECIFICATION

#### (1) LCD Appearance

\*) If the problem related to this section occurs about this item, the responsible persons of both party (Customer and HITACHI) will discuss the matter in detail.

No.	ITEM	CRITERIA				APPLIED ZONE
L C D	Scratches	Length L(mm)	Width W(mm)	Maximum number acceptable	Minimum space	A,B
		Ignored	$W \leq 0.02$	Ignored	-	
		$L \leq 40$	$0.02 < W \leq 0.04$	10	-	
		$L \leq 20$	$W \leq 0.04$	10	-	
	Dent	Distinguished one is acceptable (To be judged by HITACHI standard)				A
	Wrinkles in Polarizer	Same as above				A
	Bubbles	Average diameter D(mm)		Maximum number acceptable		A
		$D \leq 0.2$		Ignored		
		$0.2 < D \leq 0.3$		12		
		$0.3 < D \leq 0.5$		3		
		$0.5 < D$		none		
	Stains Foreign Materials	Filamentous (Line shape)				A,B
		Length L(mm)	Width W(mm)	Maximum number acceptable		
	Dark Spot	$L \leq 2.0$	$W \leq 0.03$	Ignored		
		$L \leq 3.0$	$0.03 < W \leq 0.05$	6		
		$L \leq 2.5$	$0.05 < W \leq 0.1$	1		
	Dot Defect	Round(Dot shape)				A,B
		Average diameter D(mm)	Maximum number acceptable	Minimum Space		
		$D < 0.2$	Ignored	-		
		$0.2 \leq D < 0.3$	10	10 mm		
$0.3 \leq D < 0.4$		5	30 mm			
$0.4 \leq D$		none	-			
The total number		Filamentous + Round=10				
Those wiped out easily are acceptable						
Color Tone	To be judged by HITACHI STANDARD				A	
Color Uniformity	Same as above				A	
Dot Defect			Maximum number acceptable		A	
	Sparkle mode	1 dot		4		
		2 dots		1		
		Total (Note.(3)-(f))		5		
	Black mode	1 dot		5		
		2 dots		2		
		Total (Note.(3)-(f))		5		
		Total (Note.(3)-(f))		10		

(2) CFL BACKLIGHT APPEARANCE

No.	ITEM	CRITERIA			APPLIED ZONE
C F L	Dark Spots	Average diameter D(mm)		Maximum number acceptable	A
	White Spots	$D \leq 0.4$		ignored	
	Foreign Materials (Spot)	$0.4 < D$		none	
		Foreign Materials (Line)	Width W(mm)	Length L(mm)	
B A C K L I G H T	Foreign Materials (Line)	$W \leq 0.2$	$L \leq 2.5$	1	A
		$0.2 < W$	$2.5 < L$	None	
		$0.2 < W$	-	none	
	Scratches	Width W(mm)	Length L(mm)	Maximum number acceptable	
$W \leq 0.1$		-	ignored		
$0.1 < W \leq 0.2$		$L \leq 11.0$	1		
		$11.0 < L$	None		
$0.2 < W$	-	none			

Note 1 : Definition of average diameter (D)

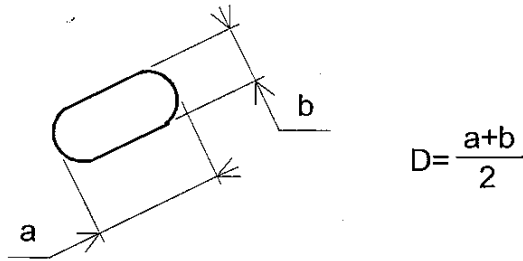

Note 2 : Definition of length (L) and width (W)

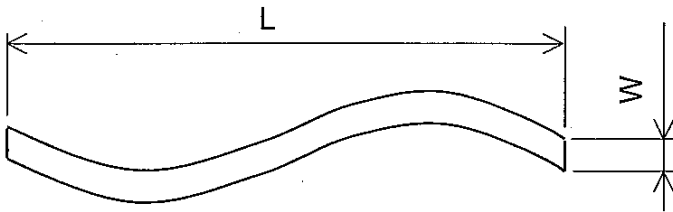

Note 3 : Definition of dot defect

- (a) Dot Defect : Defect Area > 1/2 dot
- (b) Sparkle mode : Brightness of dot is more than 30% at Black raster.
- (c) Black mode : Brightness of dot is less than 70% at R.G.B raster.
- (d) 1 dot : Defect dot is isolated , not attached to other defect dot.
- (e) N dot : N defect dots are consecutive (fig.1).  
(N means the number of defect dots.)

( fig .1)

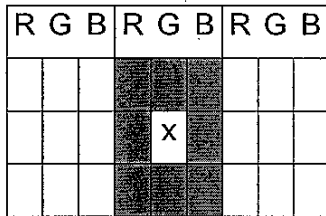

2 dots defect included defect dot "X" is defined as follows.

Adjacent dots to defect dot "X" :

- (f) Counting definition of adjacent dots (1 set) : same as 1 dot defect.
- (g) Those wiped out easily are acceptable.

## 11. PRECAUTION IN DESIG

### 11.1 PRECAUTIONS AGAINST ELECTROSTATIC DISCHARGE

As this module contains C-MOS LSIs, it is not strong against electrostatic discharge. Make certain that the operator's body is connected to the ground through a wrist band, etc. And don't touch I/F pins directly.

### 11.2 HANDLING PRECAUTIONS

- (1) As the adhesives used for adhering upper/lower polarizer's and frame are made of organic substances which will be deteriorated by a chemical reaction with such chemicals as acetone, toluene, ethanol and isopropyl alcohol. The following are recommended for use:  
normal hexane  
Please contact with us when it is necessary for you to use chemicals other than the above.
- (2) Lightly wipe to clean the dirty surface with absorbent cotton or other soft material like chamois, soaked in the recommended chemicals without scrubbing it hardly. Always wipe the surface horizontally or vertically. Never give a wipe in a circle. To prevent the display surface from damage and keep the appearance in good state, it is sufficient, in general, to wipe it with absorbent cotton.
- (3) Immediately wipe off saliva or water drop attached on the display area because it may cause deformation or faded color.
- (4) Foggy dew deposited on the surface may cause a damage, stain or dirt to the polarizer.  
When you need to take out the LCD module from some place at low temperature for test, etc.  
It is required to be warmed them up to temperature higher than room temperature before taking them out.
- (5) Touching the display area or I/F pins with bare hands or contaminating them are prohibited, because the stain on the display area and poor insulation between terminals are often caused by being touched with bare hands.  
(Some cosmetics are detrimental to polarizer's.)
- (6) In general, the glass is fragile so that, especially on its periphery, tends to be cracked or chipped in handling. Please not give the LCD module sharp shocks by falling, etc.
- (7) Maximum pressure to the surface must be less than  $1.96 \times 10^4$  Pa.  
And if the pressure area is less than  $1\text{cm}^2$ , maximum pressure must be less than 1.96N.
- (8) Since the metal width is narrow on these locations (see page 9-1/2), please careful with handling.
- (9) Top sheets shall be cleaned gently using a soft cloth such as those used for glasses. Hard wiping accumulated dust will leave scars on the surface even using a cloth.

KAOSIUNG HITACHI ELECTRONICS CO.,LTD.	DATE	May.13,'08	Sh. No.	7B64PS 2711-TX14D11VM1CBA-5	PAGE	11-1/2
--	------	------------	------------	-----------------------------	------	--------

### 11.3 OPERATION PRECAUTION

- (1) Using a LCM module beyond its maximum ratings may result in its permanent destruction.  
LCM module's should usually be used under recommended operating conditions shown in chapter 4. Exceeding any of these conditions may adversely affect its reliability.
- (2) Response time will be extremely delayed at lower temperature than the specified operating temperature range and on the other hand LCD's shows dark blue at higher temperature.  
However those phenomena do not main defects of the LCD module. Those phenomena will disappear in the specified operating temperature range.
- (3) If the display area is pushed hard during operation, some display patterns will be abnormally display.
- (4) A slight dew depositing on terminals may cause electrochemical reaction which leads to terminal open circuit. Please operate the LCD module under the relative condition of 40°C 85%RH.

### 11.4 STORAGE

In case of storing LCD module for a long period of time (for instance, for years) for the purpose of replacement use, the following precautions necessary.

- (1) Store the LCD modules in a dark place; do not expose them to sunlight or ultraviolet rays.
- (2) Keep the temperature between 10°C and 35°C at normal humidity.
- (3) Store the LCD modules in the container which is used for shipping from us.
- (4) No articles shall be left on the surface over an extended period of time.

KAOSIUNG HITACHI ELECTRONICS CO.,LTD.	DATE	May.13,'08	Sh. No.	7B64PS 2711-TX14D11VM1CBA-5	PAGE	11-2/2
--	------	------------	------------	-----------------------------	------	--------



## 12. DESIGNATION OF LOT MARK

### 12.1 LOT MARK

Lot mark is consisted of 5 digits for production lot and 6 digits for production control.

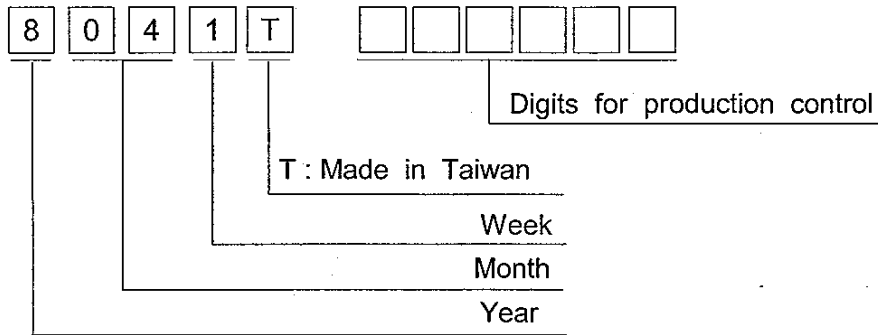

Year	Figure in lot mark
2008	8
2009	9
2010	0
2011	1
2012	2

Month	Figure in lot mark	Month	Figure in lot mark
Jan.	01	Jul.	07
Feb.	02	Aug.	08
Mar.	03	Sep.	09
Apr.	04	Oct.	10
May	05	Nov.	11
Jun.	06	Dec.	12

Week (day in calendar)	Figure in lot mark
1~7	1
8~14	2
15~21	3
22~28	4
29~31	5

### 12.2 SERIAL No.

Serial No. is consisted of 6 digits number (000001~999999).

### 12.3 LOCATION OF LOT MARK

Label is bring attached on the back side of module.

### 12.4 REVISION(Rev.) CONTROL

Rev No.	ITEM
-	CN1 JAE : FA5B040HF1
A	CN1 JAE : FA5B040HP1R3000

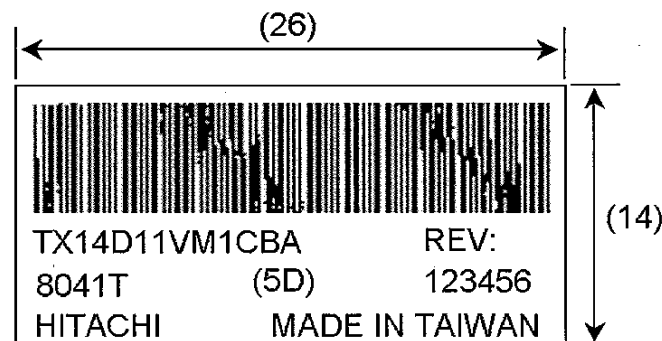

### 13. PRECAUTION FOR USE

(1) A limit sample should be provided by the both parties on an occasion when the both parties agree to its necessity.

Judgment by a limit sample shall take effect after the limit sample has been established and confirmed by the both parties.

(2) On the following occasions, the handling of the problem should be decided through discussion and agreement between responsible persons of the both parties.

(1) When a question is arisen in the specifications.

(2) When a new problem is arisen which is not specified in this specifications.

(3) When an inspection specifications change or operating condition change by customer is reported to HITACHI, and some problem is arisen in the specification due to the change.

(4) When a new problem is arisen at the customer's operating set for sample evaluation.

(3) Regarding the treatment for maintenance and repairing, both parties will discuss it in six months later after latest delivery of this product.

The precaution that should be observed when handling LCM have been explained above.

If any points are unclear or if you have any requests, please contact with HITACHI.