

Three Channel LED Driver Demoboard

General Description

The HV9982DB1 is a three channel boost LED driver demoboard using Supertex's HV9982 LED Driver IC. The LED driver can be used to drive RGB or multi channel white LEDs from a 24V input. The LED string current can be adjusted up to a maximum of 100mA. The demoboard has good current matching between strings and an excellent PWM dimming response, making it ideal for LED backlight applications.

The HV9982DB1 uses the HV9982 LED driver IC to drive three discontinuous conduction mode boost converters at a 500kHz switching frequency. The clocks of the three channels are phase shifted to provide ripple cancellation at the input and thus reducing the input capacitor requirements. The output current level can be adjusted using an external voltage source at the REF terminal.

The HV9982DB1 includes hiccup mode protection for both short circuit and open circuit conditions to ensure that it recovers from a momentary fault condition. It also enables the board to survive prolonged fault conditions without any damage to both the driver as well as the LEDs.

The HV9982DB1 also includes an on-board PWM generator for analog control for PWM dimming (for backward compatibility with CCFL controllers). This feature enables the user to PWM dim the driver with a 0-2V analog signal input and helps to achieve zero LED current with an analog dimming input

Specifications

Parameter	Value
Input voltage	24V ± 10%
LED string voltage (all channels)	35V – 80V
LED current (all channels)	100mA (max)
Switching frequency of the converter at $F_{CLK} = 6.0\text{MHz}$	500kHz
External frequency at CLK pin	6MHz
Current matching between channels	≤ ± 3%
Typical full load efficiency	90%
PWM dimming rise and fall times	≤ 1μs
PWM dimming frequency (for analog control of PWM dimming)	480Hz (typ)
Shutdown mode current	≤ 600μA
Typical I_{DD} current (for all three channels)	12mA ($V_{DD} = 8\text{V}$)
Open LED protection	Included; hiccup-mode
Output short circuit protection	Included; hiccup-mode
Hiccup time	1ms (typ)

Connection Diagram

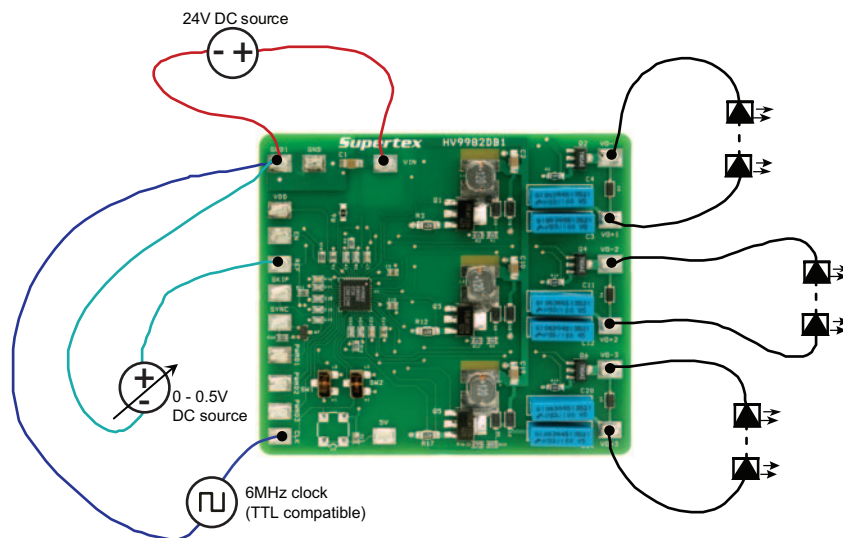

Connections

Pin	Connection
VIN	This terminal is the positive input of the 24V supply for the boost converters. It is also the input for the internal regulator of the IC.
GND, GND1	These terminals are the return paths for all the input voltages and signals for the demoboard. All voltages and signals (other than the output terminals) should be referenced to these two terminals.
VDD	This terminal is connected to the VDD pins of the IC. When left unconnected, the voltage at this terminal will be regulated to 7.75V by the internal regulator of the HV9982. To supply the IC with an external VDD supply, connect an 8-10V source to this terminal.
EN	This terminal can be used to shut down the IC. Connecting this terminal to GND will cause the IC to go into a standby mode and draw less than 500µA.
CLK	This terminal is the clock input to the IC. A TTL compatible 6MHz clock should be connected to this terminal. In case an on-board clock is preferred, a 6MHz fixed frequency oscillator can be soldered in at U2 (please refer to BOM for the part number).
5V	A 5.0V, 50mA source needs to be connected to this point, if an on-board clock is used. This provides the power required for the fixed frequency oscillator at U2. This terminal can be left open if an external 6.0MHz clock is used.
REF	This terminal is the control input for adjusting the LED current level. A 0 – 500mV voltage source should be connected to this terminal.
S1, S2	These two switches on the demoboard control the PWM dimming function. They can be used to enable either direct PWM dimming of the channels using an external TTL signal or analog control of PWM dimming using a 0-2.0V analog signal. The control logic for these switches is given in Table 1.
PWMD1-3	These terminals are the PWM dimming inputs. The inputs can be either TTL compatible square wave signals or 0-2.0V analog signals depending on the configuration of switches S1 and S2.
VO+1-3	The anodes of the LED strings should be connected to these terminals as shown in the connection diagram.
VO- 1-3	The cathodes of the LED strings should be connected to these terminals as shown in the connection diagram.
SKIP	This terminal is connected to the hiccup timing capacitor and can be used to measure the hiccup time.
SYNC	This terminal can be used to synchronize the internal PWM ramp to an external clock. A TTL compatible, 350Hz – 400Hz external clock with a pulse width less than 2% can be applied at this terminal to synchronize the internal ramp to the external clock.

Table 1 : Truth Table for S1 and S2

S1	S2	PWMD Output
LO	LO	The output will follow PWMD input signal
LO	HI	
HI	LO	Input DC zero volt corresponds to 100% duty cycle output
HI	HI	Input DC two volt corresponds to 100% duty cycle output

Testing the Demoboard

Normal Operation – Connect the board as shown in the connection diagram. Ensure that switches S1 and S2 are LO. Turn on the clock, 24V supply and the reference voltage. Connect any of the PWMD pins to VDD. The LEDs of the corresponding channel will light up. Measure the LED current using an ammeter and the reference voltage using a voltmeter. The current will be:

$$I_{LED} = \frac{V_{REF}}{4.99} \pm 3.0\% \quad (1)$$

Current matching – Without changing the reference voltage, enable each channel individually and measure the current (or, if possible, enable all channels and the three output currents simultaneously). The error will be $\leq \pm 3\%$.

Linear Dimming – Vary the reference voltage between 0 – 500mV and measure the LED current.

The current will vary as per Eqn.1. This variation is fairly linear until the REF voltage gets very low. As the voltage goes below 50mV, the current will not match the reference voltage as linearly.

PWM Dimming – With the reference voltage fixed at 0.5V, apply a TTL compatible square wave signal ($\leq 1\text{kHz}$). The LED current will dim based on the duty cycle of the PWM input.

Analog Control of PWM Dimming – Change S1 and S2 as required using Table 1. Connect the analog 0-2V source at the PWMD terminal and turn on the demoboard. The LEDs will dim and the LED current can be adjusted by varying the analog voltage.

Open LED protection – Connect a voltage probe between the VO+ terminal of any channel and GND and disconnect the LED string. The output voltage will rise up to 92V and trip the over voltage protection. At this point, all three channels will shut down and the output voltage of the channel with the open LED condition will be maintained hysteretically between 92V and 82V until the output voltage of the faulty channel falls below 82V or till the LED string is reconnected. Once the LED string is reconnected, all three channels will turn back on.

Short Circuit Protection – Short the output terminals of any one channel using a jumper. All three channels shut down and the IC tries restarting every 1.0ms. Once the short circuit is removed, all three channels come back into regulation.

Typical Results

Normal Operation – Fig.1 shows the waveforms during normal operation at full load and 24V input. The smaller pulses in the drain waveforms represent the ringing between the input inductor of the boost converter and the parasitic capacitance at the drain pin of the switching FET. This is a normal occurrence in any discontinuous mode converter.

Fig. 1: Waveforms for Normal Operations

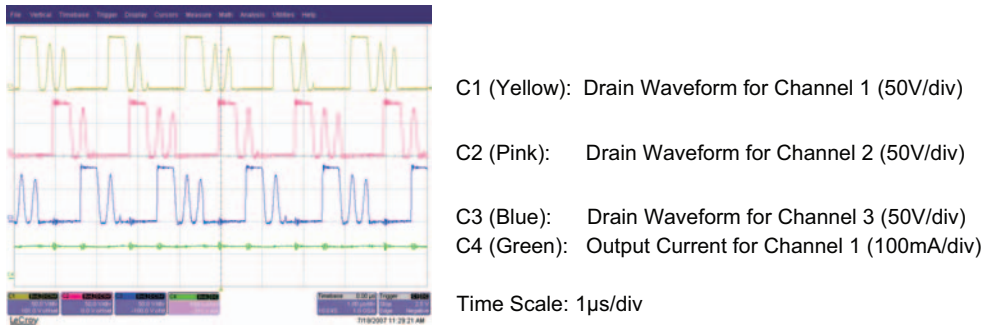

Startup – Fig. 2 shows the startup waveforms. These waveforms were obtained by connecting the PWM pins to VDD and applying a step waveform at the 24V input. There is a 500µs delay before the ramp voltage starts rising. This delay is due to the time required to charge the capacitors at the VDD pins plus the internal power-on-reset time. The other part of the delay is the time required by the ramp capacitor to charge to 5V. Once the RAMP voltage reaches 5V, the converter starts switching and the LED current starts up slowly without any overshoots.

Fig. 2: Startup Waveforms

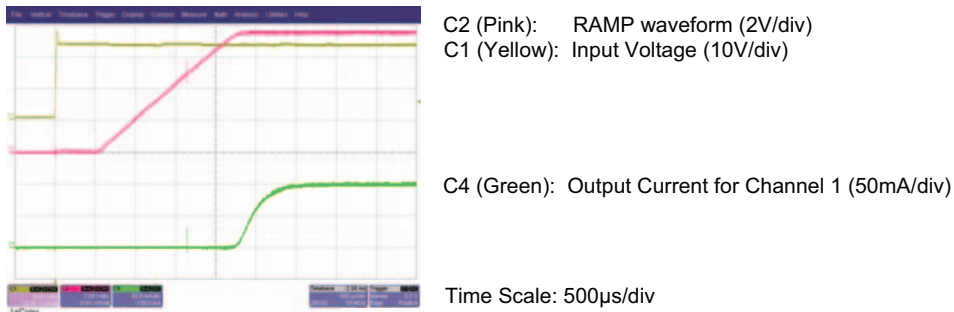

Open LED Protection – Figs.3-6 show the over voltage protection in operation. Fig. 3 shows the open circuit condition occurring when the LED current goes to zero. At this point, the output voltage starts increasing since the energy from the input is used to charge the output capacitors. Once the output voltage reaches 92V, all three channels are shut down (Note:

Fig. 3: Over Voltage Trigger

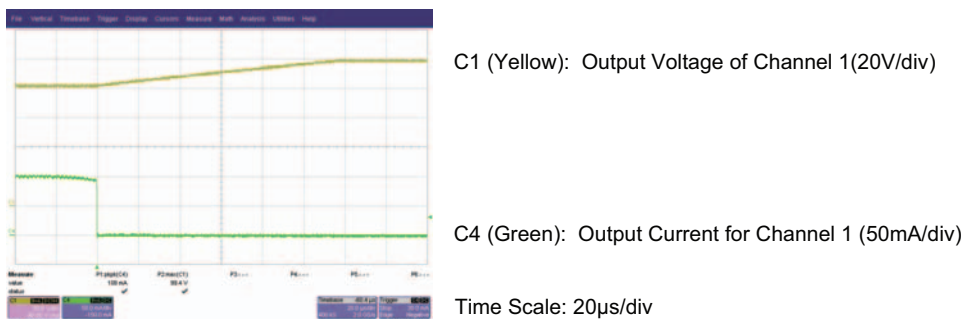

Output Voltage refers to VO+ voltage measured w.r.t GND). The hysteretic over voltage protection is shown in Fig. 4 where the output voltage is consistently maintained between 82V and 92V.

Fig. 4: Open LED Operation

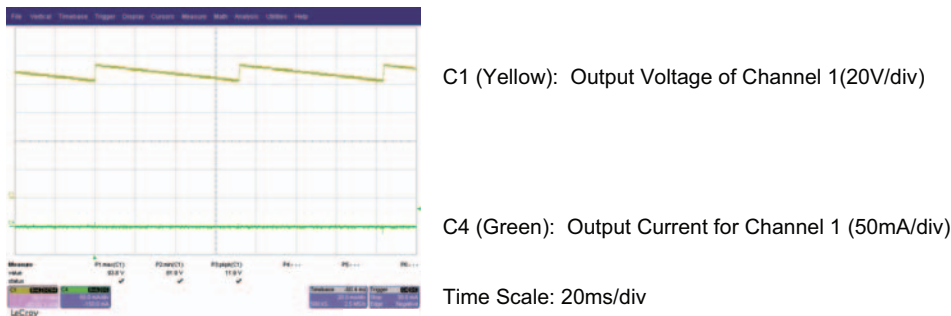

The recovery from an open LED condition is shown in Fig. 5. Two spikes are observed in the LED current. These spikes are caused by the output capacitor discharging into the LEDs since the capacitor voltage is higher the LED string voltage. This causes the HV9982 to go into a hiccup mode short circuit condition till the capacitor voltage becomes lower than the LED string voltage (as seen by the dip the output voltage). Once all fault conditions are cleared, the LED current starts up smoothly into normal operation. Fig. 6 shows the recovery with a smaller timescale.

Fig. 5: Recovery from Open LED Operation

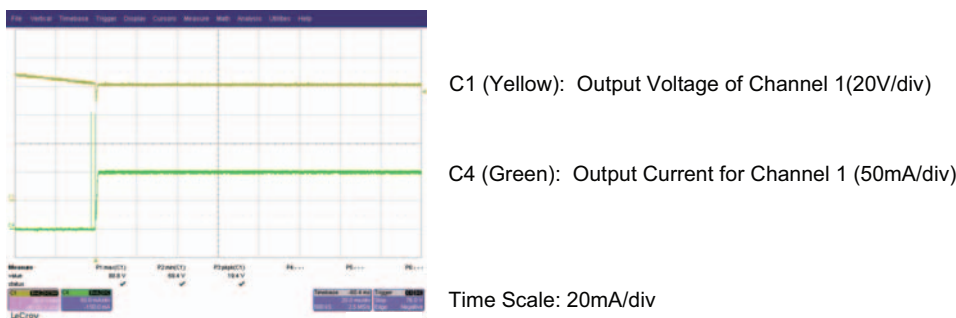
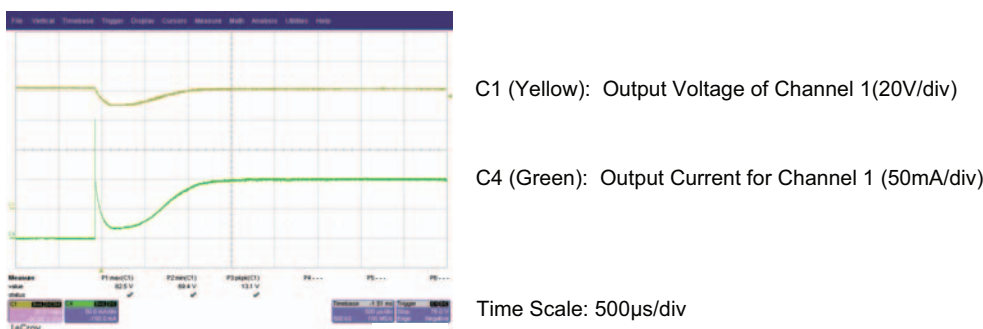

Fig. 6: Recovery (smaller timescale)



Short Circuit Protection – Figs. 7-9 show the operation of the short circuit protection. Fig. 7 shows the response of the HV9982 to a short circuit condition. The short circuit condition occurs when the output current starts rising and the circuit shuts down in less than 200ns, providing a very fast response to an output short circuit (Note: LED string voltage refers to VO+ voltage measured w.r.t its corresponding VO-).

The hiccup mode operation is shown in Fig. 8. The converter tries to restart every 1ms and if the short circuit condition is still detected, the converter shuts down.

The recovery from the short circuit condition is shown in Fig. 9. The LED current starts up without any overshoots.

Fig. 7: Waveforms for Normal Operations



C4 (Green): Output Current for Channel 1 (200mA/div)

Ma (Orange): LED String Voltage of Channel 1(20V/div)

Time Scale: 200ns/div

Fig. 8: Short Circuit Hiccup



C1 (Yellow): Output Voltage of Channel 1(20V/div)

C4 (Green): Output Current for Channel 1 (200mA/div)

Time Scale: 1ms/div

Fig. 9: Short Circuit Recovery



C1 (Yellow): Output Voltage of Channel 1(20V/div)

C4 (Green): Output Current for Channel 1 (200mA/div)

Time Scale: 500µs/div

PWM Dimming Operation – PWM Dimming operation with an external TTL square wave signal is shown in Figs. 10-12. Fig. 10 shows the overall operation of the circuit with a PWM dimming input and Figs. 11 and 12 show the rise and fall times of the LED current during PWM dimming.

In some cases, depending on the parasitic capacitance of the LED string, there may be narrow spike in the LED current during the rising edge. To prevent this spike from shutting down the HV9982 due to a short circuit condition being falsely detected, an internal 500ns blanking is provided in the IC. Fig. 13 shows the rising edge of the PWM dimming operation of the same LED driver with a different LED load (which has a significant parasitic capacitance).

Fig. 10: PWM Dimming



C1 (Yellow): PWM Dimming Input for Channel 1(5V/div)

C4 (Green): Output Current for Channel 1 (50mA/div)

Time Scale: 500µs/div

Fig. 11: PWM Dimming – Rise Time

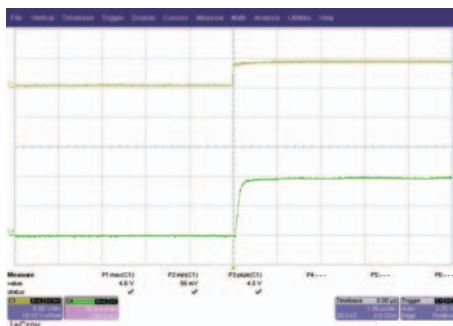

C1 (Yellow): PWM Dimming Input for Channel 1(5V/div)

C4 (Green): Output Current for Channel 1 (50mA/div)

Time Scale: 1µs/div

Fig. 12: PWM Dimming – Fall Time



C1 (Yellow): PWM Dimming Input for Channel 1(5V/div)

C4 (Green): Output Current for Channel 1 (50mA/div)

Time Scale: 1µs/div

Fig. 13: Current Spike during PWM Dimming

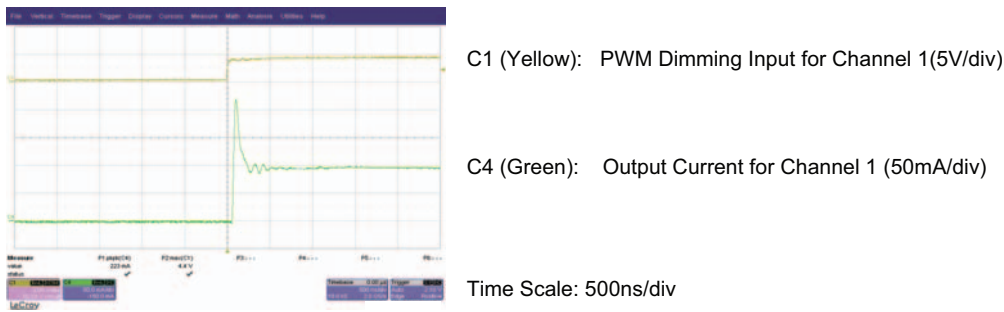

Analog Control of PWM Dimming – The operation of the analog control of PWM dimming is shown in Figs. 14-16. Fig. 14 shows the waveforms for operation in one of the modes (S1=HI; S2=HI), with no external SYNC signal applied. The plots in Figs. 15 and 16 show the operation with an external 350Hz synchronizing clock. Fig. 15 shows the waveforms with S1=HI and S2=LO and Fig. 16 shows the waveforms with S1=HI and S2=HI. Fig. 17 shows the variation of the average LED current with the voltage at the PWMD pin in these modes of operation.

Fig. 14: Analog Control of PWM Dimming w/o external clock (S1 = HI and S2 = HI)

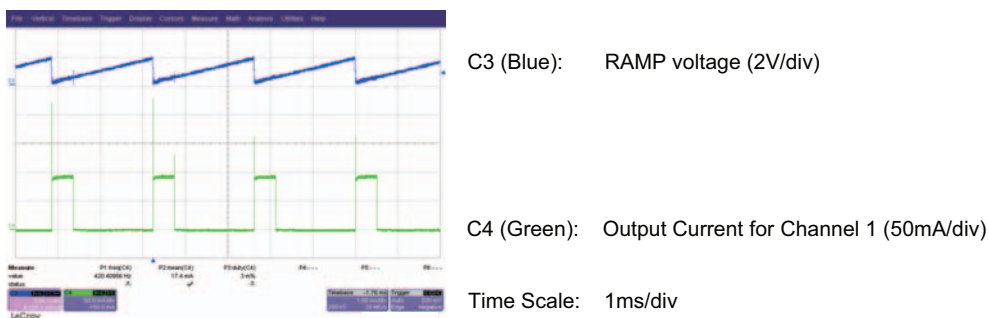

Fig. 15: Analog Control of PWM Dimming synchronized to external clock (S1 = HI and S2 = LO)

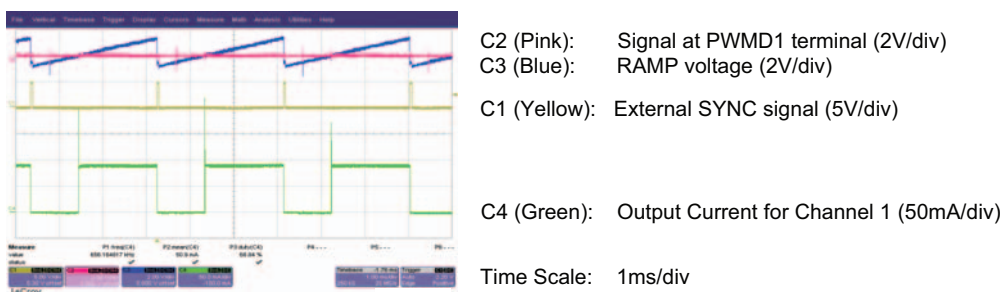

Fig. 16: Analog Control of PWM Dimming synchronized to external clock (S1 = HI and S2 = HI)

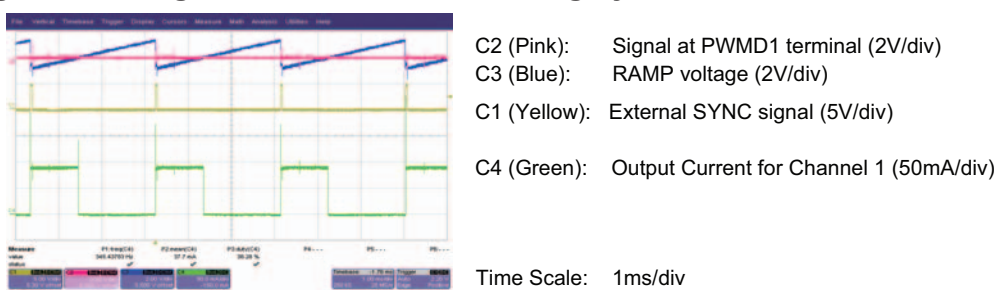
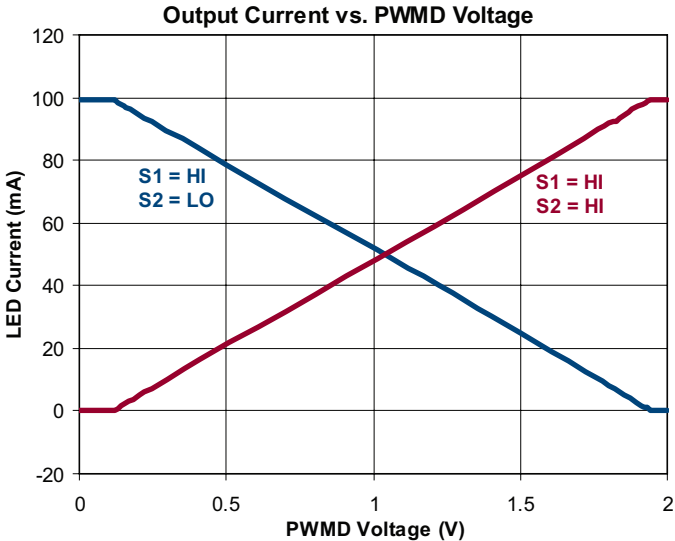
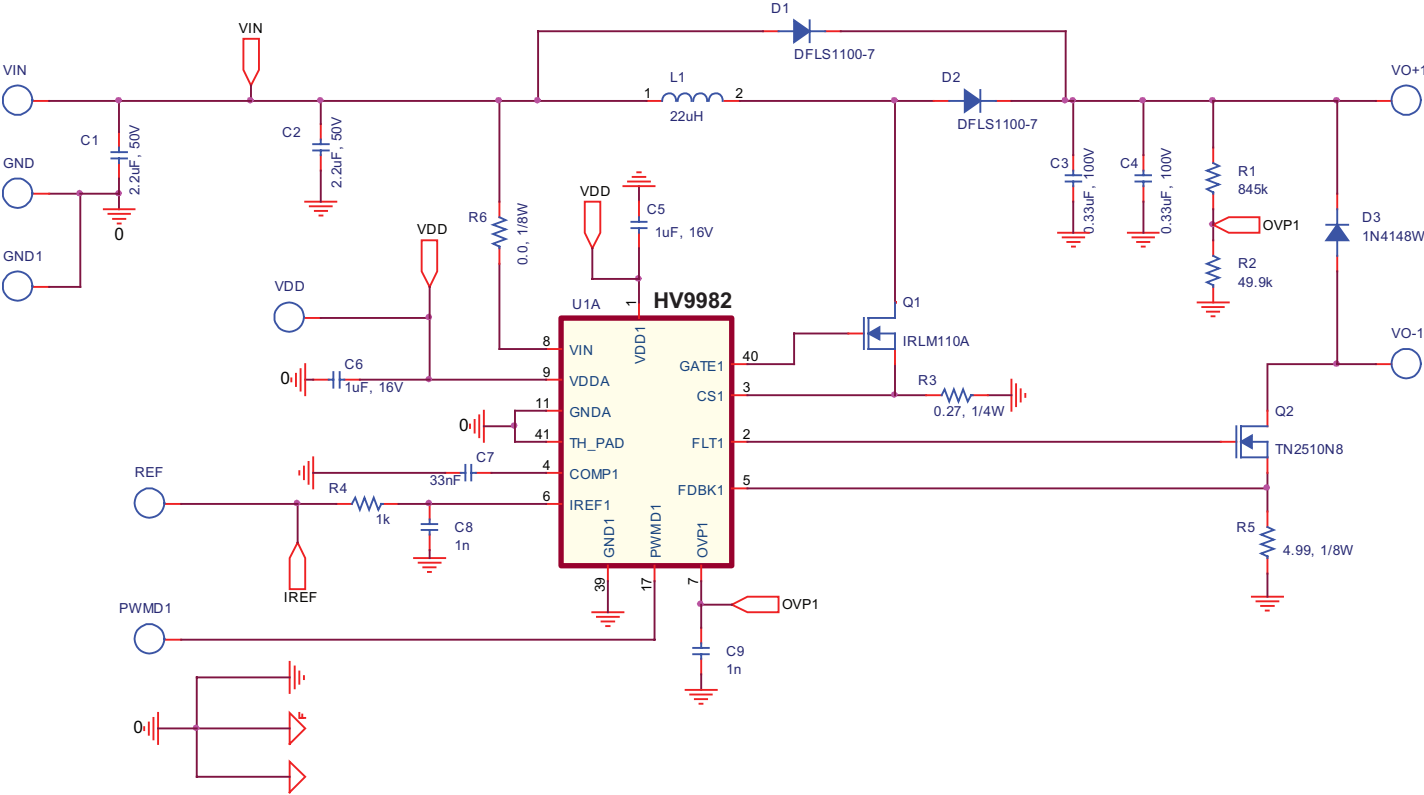

Fig. 17: Analog Control of PWM Dimming - Measurements



Circuit Schematic - Part 1 of 3



Bill of Materials

Item #	Quan.	RefDes	Description	Package	Manufacturer	Manufacturer's Part #
1	20	VO-1-3, VO+1-3, PWMD1-3, GND, GND1, VIN, VDD, SKIP, REF, SYNC, EN, CLK, 5V	Compact surface mount test points	SMT	Keystone Electronics	5016
2	4	C1,C2, C10,C19	2.2uF, 50V, X7R ceramic chip capacitor	SMD1206	Murata	GRM31CR71H225KA88L
3	6	C3,C4, C11,C12,C20,C21	0.33uF, 100V metal film capacitor	Radial	EPCOS Inc	B32521C1334J
4	5	C5,C6, C13,C22,C26	1uF, 16V X7R ceramic chip capacitors	SMD0603	Taiyo Yuden	EMK107BJ105KA-TR
5	3	C7,C16, C23	33nF, 16V, X7R ceramic chip capacitor	SMD0603	Murata	GRM188R71C333KA01D
6	6	C8,C9, C17,C18,C24,C25	1nF, 50V, C0G ceramic chip capacitor	SMD0603	Murata	GRM1885C2A102JA01D
7	2	C14,C15	2nF, 50V, C0G ceramic chip capacitor	SMD0603	Murata	GRM1885C1H202JA01D
8	6	D1,D2,D4,D5,D7,D8	100V, 1A schottky diode	PowerDI123	Diodes Inc	DFLS1100-7
9	7	D3,D6,D9	100V, 300mA switching diode	SOD-123	Diodes Inc	1N4148W-7
10	3	L1,L2,L3	22uH, 1.2A rms, 1.5A sat inductor	SMT	Würth Electronik	744774122
11	3	Q1,Q3,Q5	100V, 0.44ohm, 1.5A N-channel MOSFET	SOT-223	Fairchild Semi	IRLM110A
12	3	Q2,Q4,Q6	100V, 1.5ohm, N-channel MOSFET	SOT-89	Supertex	TN2510N8
13	1	Q7	30V, 1.6A N-channel MOSFET	SOT-23	Fairchild Semi	NDS355N
14	3	R1,R9, R15	845kΩ, 1/10W, 1% chip resistor	SMD0603	---	---
15	3	R2,R11, R16	49.9kΩ, 1/10W, 1% chip resistor	SMD0603	---	---
16	3	R3,R12, R17	0.27Ω, 1/4W, 5% chip resistor	SMD1206	---	---
17	3	R4,R13, R18	1kΩ, 1/10W, 5% chip resistor	SMD0603	---	---
18	3	R5,R14, R19	4.99Ω, 1/8W, 1% chip resistor	SMD0805	---	---
19	1	R6	0.0Ω, 1/8W chip resistor	SMD0805	---	---
20	1	R10,R20	100kΩ, 1/10W, 1% chip resistor	SMD0603	---	---
21	2	SW1,SW2	SPDT Gull Wing slide switch	SMT	Copal Electronics Inc	CJS-1200TB
22	1	U1	Three-channel closed-loop LED Driver	QFN-40	Supertex	HV9982K6-G
23	1	U2	6.176MHz fixed frequency oscillator (optional)	SMT	Citizen America	CSX750PCC6.1760M-UT

Supertex inc. does not recommend the use of its products in life support applications, and will not knowingly sell its products for use in such applications, unless it receives an adequate "product liability indemnification insurance agreement". **Supertex** does not assume responsibility for use of devices described and limits its liability to the replacement of the devices determined defective due to workmanship. No responsibility is assumed for possible omissions or inaccuracies. Circuitry and specifications are subject to change without notice. For the latest product specifications, refer to the **Supertex** website: <http://www.supertex.com>.

©2007 **Supertex inc.** All rights reserved. Unauthorized use or reproduction is prohibited.

Supertex inc.

1235 Bordeaux Drive, Sunnyvale, CA 94089
TEL: (408) 222-8888 / FAX: (408) 222-4895

www.supertex.com