

24V DRIVE INTERFACE BOARD (PARALLEL)

FTP-622DCL001/011/101/111

FOR FTP-622/632/642MCL001/002/301/302/303/304

■ INTERFACE

1. Centronics

(1) Connector (CN1)

Connector part number : FCN-605Q030-G/S (Fujitsu Components)

Mating connector part number : FCN-607B030-G/D (Fujitsu Components) or equivalent

(2) Connector pin assignment

No.	Signal	I/O	Contents	No.	Signal	I/O	Contents
1	PRSTB	I	Data strobe	2	$\overline{\text{PRSTB}}\text{-RET}$	—	Connected to logic GND
3	PRDT0	I	Data 0	4	PRDT0-RET	—	Connected to logic GND
5	PRDT1	I	Data 1	6	PRDT1-RET	—	Connected to logic GND
7	PRDT2	I	Data 2	8	PRDT2-RET	—	Connected to logic GND
9	PRDT3	I	Data 3	10	PRDT3-RET	—	Connected to logic GND
11	PRDT4	I	Data 4	12	PRDT4-RET	—	Connected to logic GND
13	PRDT5	I	Data 5	14	PRDT5-RET	—	Connected to logic GND
15	PRDT6	I	Data 6	16	PRDT6-RET	—	Connected to logic GND
17	PRDT7	I	Data 7	18	PRDT7-RET	—	Connected to logic GND
19	$\overline{\text{ACKNLG}}$	O	Data input acknowledge	20	$\overline{\text{ACKNLG}}\text{-RET}$	—	Connected to logic GND
21	BUSY	O	Busy	22	BUSY-RET	—	Connected to logic GND
23	RINF2	O	Printer status	24	$\overline{\text{INPRM}}\text{-RET}$	—	Connected to logic GND
25	$\overline{\text{SLCTIN}}$	I	Printer select	26	$\overline{\text{INPRM}}$	I	Reset
27	RINF1	O	Printer status	28	RINF3	O	Printer status
29	$\overline{\text{ATF}}$	I	Paper feed request	30	GND	—	Logic GND

Notes:

- Symbol “—” means a negative logic signal.
- “-RET” signal is a return signal of the twisted pair cable.
- “I” or “O” means a signal direction from the interface board side.

(3) Connector pin number

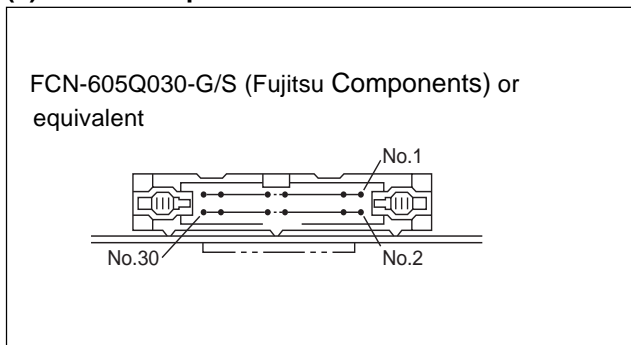

(4) Data input signal timing

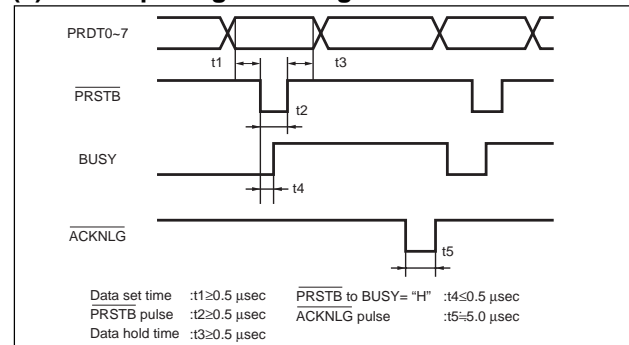

■ CONNECTOR PIN ASSIGNMENT

1. Connector for power supply (CN10)

Part number : B6P-VH (J.S.T)

Mating connector part number : VHR-6N (J.S.T) or equivalent

No.	Signal	I/O	Contents	No.	Signal	I/O	Contents
1	V _{CC}	—	Power supply for logic (+5 V)	2	GND	—	GND (5 V, 24 V common)
3	GND	—	GND (5 V, 24 V common)	4	GND	—	GND (5 V, 24 V common)
5	V _{DD}	—	Power for head/motor (+24 V)	6	V _{DD}	—	Power for head/motor (+24 V)

2. Connector for thermal head drive (CN8)

Part number : B16B-PH-K-S (J.S.T)

Mating connector part number : PHR-16 (J.S.T) or equivalent

No.	Signal	I/O	Contents	No.	Signal	I/O	Contents
1	VDH	O	Power for head (+24 V)	2	VDH	O	Power for head (+24 V)
3	GND (VDH)	—	Head GND	4	GND (VDH)	—	Head GND
5	$\overline{\text{STB1}}$	O	Print enable signal 1	6	$\overline{\text{STB2}}$	O	Print enable signal 2
7	$\overline{\text{STB3}}$	O	Print enable signal 3	8	TMP	I	Temperature detection signal
9	$\overline{\text{STB4}}$	O	Print enable signal 4	10	$\overline{\text{LAT}}$	O	Print data latch signal
11	$\overline{\text{STB5}}$	O	Print enable signal 5	12	5 VH	O	Power for logic (+5 V)
13	HCLK	O	Data transmission clock	14	HD	O	Print data output signal
15	GND (VDH)	—	Head GND	16	VDH	O	Power for head (+24 V)

Notes:

- Symbol “—” means a negative logic signal.
- “I” or “O” means a signal direction from the interface board side.

3. Connector for Sensor (CN3)

Part number : B5B-PH-K-S (J.S.T)

No.	Signal	I/O	Contents	No.	Signal	I/O	Contents
1	+5 V	—	Power for logic (+5 V)	2	$\overline{\text{PES}}$	I	Paper end detect signal
3	GND (5 V)	—	Logic GND	4	+5 V	—	Power for logic (+5 V)
5	HUP	I	Head-up detect signal				

4. Connector for paper near end detection (CN5)

Part number : B2B-PH-K-S (J.S.T)
 Mating connector part number : PHR-2 (J.S.T) or equivalent

No.	Signal	I/O	Contents	No.	Signal	I/O	Contents
1	+5 V	—	Power for logic (+5 V)	2	$\overline{\text{NES}}$	I	Paper near end detect signal

5. Connector for stepping motor drive (CN13)

Part number : B4B-PH-K-S (J.S.T)

No.	Signal	I/O	Contents	No.	Signal	I/O	Contents
1	$\text{MT}/\overline{\text{B}}$	O	Stepping motor coil excitation	2	MT/B	O	Stepping motor coil excitation
3	$\text{MT}/\overline{\text{A}}$	O	Stepping motor coil excitation	4	MT/A	O	Stepping motor coil excitation

6. Connector for cutter drive (CN11) *1

Part number : B4B-EH (J.S.T)

No.	Signal	I/O	Contents	No.	Signal	I/O	Contents
1	SW1	I	Cutter position detect signal	2	GND	—	Logic ground
3	M+	O	Motor control signal (+)	4	M-	O	Motor control signal (-)

*1: Only for FTP-622DCL011/111.

■ PRINTING COMMANDS (CENTRONICS INTERFACE)

Command	Contents
HT	Moves the print position to the next tab.
LF	Line feed.
FF	Feeds forms (new page).
ESC RS	Sets reverse printing.
ESC US	Resets reverse printing.
ESC ! +n	Sets print mode.
ESC* +m+n ₁ +n ₂ +d ₁ ~d _N	Sets the bit image mode "m" for n ₁ , n ₂ dot numbers.
ESC 2	Sets 1/6 inch line feed length.
ESC 3 + n	Sets the line feed length.
ESC @	Printer initialization.
ESC A+n	Sets the space between lines.
ESC C+n	Sets the page length by character line.
ESC D+d ₁ ~d _N +NUL	Sets the tab position.
ESC J+n	Feeds paper in forward direction.
ESC K+n	Feeds paper in reverse direction.
ESC c+1+n	Sets the internal processing.
ESC R+n	Selects the international character.
ESC s+n	Sets the printing speed.
ESC d+n	Printing and n-line feeding.
ESC e+n	Reverse line feed in "n" lines after printing.
ESC t+n	Character code table selection.
ESC {+n	Sets/resets the upside down printing.
ECS EM+n	Automatic paper feed distance setting.
ESC X+n+m	Setting turning time of the motor excitation.
ESC V+n	Right Rotation 90° specification / cancellation.
FS E+n	Correction of impressed energy.
FS ! +n	Sets the Kanji print mode* ¹ .
FS &	Sets Kanji mode* ¹ .
FS .	Resets Kanji mode* ¹ .
FS C+n	Selects Kanji code type* ¹ .

(Continued)

(Continued)

Command	Contents
FS 9+n	Sets the detection functions.
FS W+n	Sets/resets 4 times enlarged character.
GS <	Line feeds to the next mark.
GS A+m+n	Sets the line feed length after mark detection.
GS E+n	Sets print quality.
GS V+n+m	Executes paper cutting*2.
GS e+n+m	Sets the bar width.
GS h+n	Sets the barcode height.
GS k+m+n+d ₁ ~d _n	Selects the barcode type and prints.
GS w+n	Sets the barcode length.
GS &+m+x+y ₁ +y ₂ +[d]k	Registration of image data..
GS '+m+n	Prints registered image data..
GS a+n	Sets and cancels status transmission (valid only for DSL).

*2: Only for FTP-622DCL011/111.

■ OPTIONS

1. Cable (With FTP-622MCL, FTP-632MCL, FTP-642MCL)

Name		Part Number	Cable Length
Thermal head connection cable (CN8)*		FTP-622Y001	270 mm (10.6 inches)
Interface cable	Centronics (CN1)	FTP-622Y201	500 mm (19.71 inches)
Power cable for head, motor, and logic (CN10)		FTP-622Y401	300 mm (11.8 inches)
* short cable option		FTP-624Y001	150 mm (5.9 inches)

2. Paper holder

Name	Part number
Flange	FTP-040HF
Stand	FTP-040HS

Fujitsu Components International Headquarter Offices	Japan Fujitsu Component Limited Gotanda-Chuo Building 3-5, Higashigotanda 2-chome, Shinagawa-ku Tokyo 141, Japan Tel: (81-3) 5449-7010 Fax: (81-3) 5449-2626 Email: promothq@ft.ed.fujitsu.com Web: www.fcl.fujitsu.com	Europe Fujitsu Components Europe B.V. Diamantlaan 25 2132 WV Hoofddorp Netherlands Tel: (31-23) 5560910 Fax: (31-23) 5560950 Email: info@fceu.fujitsu.com Web: www.fceu.fujitsu.com
	North and South America Fujitsu Components America, Inc. 250 E. Caribbean Drive Sunnyvale, CA 94089 U.S.A. Tel: (1-408) 745-4900 Fax: (1-408) 745-4970 Email: marcom@fcai.fujitsu.com Web: www.fcai.fujitsu.com	Asia Pacific Fujitsu Components Asia Ltd. 102E Pasir Panjang Road #04-01 Citilink Warehouse Complex Singapore 118529 Tel: (65) 6375-8560 Fax: (65) 6273-3021 Email: fcal@fcal.fujitsu.com www.fcal.fujitsu.com

© 2002 Fujitsu Components America, Inc. All company and product names are trademarks or registered trademarks of their respective owners. Rev. 06/2002