



## 6.6 Megapixel CMOS Image Sensor

### Features

- 2210 (H) x 3002 (V) Active Pixels
- 3.5  $\mu\text{m}$  x 3.5  $\mu\text{m}$  Square Pixels
- 1 inch Optical Format
- Monochrome Output
- Frame Rate:
  - 5 fps for active window of 2210 x 3002)
  - 89 fps for active window of 640 x 480)
- High Dynamic Range Modes: Double Slope, Non Destructive Read out (NDR)
- Electronic Rolling Shutter
- Master Clock: 40 MHz
- Single 2.5V supply
- 3.3V supply for extended dynamic range
- -30°C to +65°C Operational Temperature Range
- 68-Pin LCC Package
- Power Dissipation: 225 mW

### Applications

- Machine Vision
- Biometry
- Document Scanning

### Ordering Information

Marketing Part Number	Description	Package
NOI4SM6600A-QDC	Mono with Glass	68 pin LCC

**Note** For more information, see [Ordering Code Definition](#) on page 29.

### Description

The IBIS4-6600 is a solid-state CMOS image sensor that integrates complete analog image acquisition, and a digitizer and digital signal processing system on a single chip. This image sensor has a resolution of 6.6 MPixel with 2210 x 3002 active pixels. The image size is fully programmable for user-defined windows. The pixels are on a 3.5  $\mu\text{m}$  pitch.

The user programmable row and column start and stop positions enable windowing down to 2x1 pixel window for digital zoom. Subsampling reduces resolution while maintaining the constant field of view. The analog video output of the pixel array is processed by an on-chip analog signal pipeline. Double Sampling (DS) eliminates the fixed pattern noise.

The programmable gain and offset amplifier maps the signal swing to the ADC input range. A 10-bit ADC converts the analog data to a 10-bit digital word stream. The sensor uses a three-wire Serial-Parallel (SPI) interface. It operates with a single 2.5V power supply and requires only one master clock for operation up to 40 MHz. It is housed in a 68-pin ceramic LCC package.

This data sheet enables the development of a camera system, based on the described timing and interfacing given in the following sections.

**Figure 1. IBIS4-6600 Image Sensor**

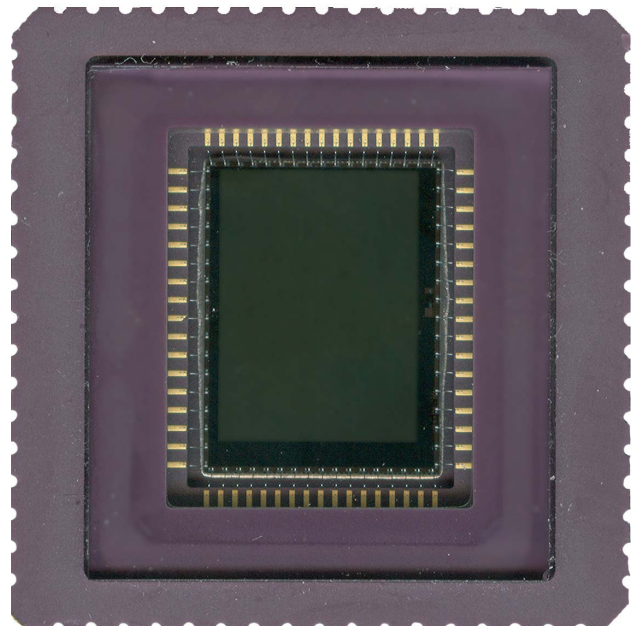

## Contents

<b>Features</b> .....	<b>1</b>	Electronic Shutter .....	15
<b>Applications</b> .....	<b>1</b>	High Dynamic Range Modes.....	16
<b>Description</b> .....	<b>1</b>	<b>Sequencers and Registers</b> .....	<b>17</b>
<b>Ordering Information</b> .....	<b>1</b>	Description of Registers .....	19
<b>Contents</b> .....	<b>2</b>	<b>Timing Diagrams</b> .....	<b>23</b>
<b>Specifications</b> .....	<b>3</b>	Sequencer Control Signals.....	23
Key Specifications .....	3	Basic Line and Frame Timing .....	23
General Specifications .....	3	Pixel Output Timing .....	24
Electro-Optical Specifications .....	3	ADC Timing .....	25
Spectral Response Curve .....	4	<b>Package Information</b> .....	<b>26</b>
Photo Voltaic Curve .....	5	Pin List .....	26
Electrical Specifications .....	6	Package Outline Drawing .....	28
<b>Sensor Architecture</b> .....	<b>7</b>	Glass Lid .....	29
Floor Plan .....	7	<b>Handling Precautions</b> .....	<b>29</b>
Pixel .....	8	<b>Limited Warranty</b> .....	<b>29</b>
Output Amplifier.....	8	Return Material Authorization (RMA) .....	29
Analog to Digital Converter .....	10	<b>Acceptance Criteria Specification</b> .....	<b>29</b>
Serial Peripheral Interface (SPI).....	11	<b>Ordering Code definition</b> .....	<b>29</b>
<b>Sensor Operation</b> .....	<b>12</b>	<b>Acronym</b> .....	<b>30</b>
Pixel Rate .....	12	<b>Glossary</b> .....	<b>31</b>
Region of Interest Read out .....	12	<b>Document History Page</b> .....	<b>32</b>
Subsampling modes.....	12		

## Specifications

### General Specifications

Parameter	Specification	Remarks
Pixel Architecture	3T-Pixel	
Pixel Size	3.5 $\mu\text{m}$ x 3.5 $\mu\text{m}$	The resolution and pixel size results in a 7.74 mm x 10.51 mm optical active area.
Resolution	2210 x 3002	
Pixel Rate	40 MHz	Using a 40 MHz system clock and 1 or 2 parallel outputs
Shutter Type	Electronic Rolling Shutter	
Full Frame Rate	5 frames/second	Increases with ROI read out and/or subsampling

### Electro Optical Specifications

Parameter	Specification	Remarks
FPN (local)	<0.20%, 2 LSB10	%RMS of saturation signal
PRNU (local)	<1.5%	RMS of signal level
Conversion Gain	43 $\mu\text{V}/\text{e}^-$	At output (measured)
Output Signal Amplitude	0.6V	At nominal conditions
Saturation Charge	21500 $\text{e}^-$	
Sensitivity (peak)	411 $\text{V}\cdot\text{m}^2/\text{W}\cdot\text{s}$ 4.83 $\text{V}/\text{lux}\cdot\text{s}$	At 650 nm (85 lux = 1 $\text{W}/\text{m}^2$ )
Sensitivity (visible)	328 $\text{V}\cdot\text{m}^2/\text{W}\cdot\text{s}$ 2.01 $\text{V}/\text{lux}\cdot\text{s}$	400-700 nm (163 lux = 1 $\text{W}/\text{m}^2$ )
Peak QE * FF Peak Spectral Response	25% 0.13 A/W	Average QE*FF = 22% (visible range) Average SR*FF = 0.1 A/W (visible range) See the section <a href="#">Spectral Response Curve</a> on page 4.
Fill Factor	35%	Light sensitive part of pixel (measured)
Dark Current	3.37 mV/s 78 $\text{e}^-/\text{s}$	Typical value of average dark current of the whole pixel array (at 21°C)
Dark Signal Non Uniformity	8.28 mV/s 191 $\text{e}^-/\text{s}$	Dark current RMS value (at 21°C)
Temporal Noise	24 RMS $\text{e}^-$	Measured at digital output (in the dark)
Signal/Noise Ratio	895:1 (40 dB)	Measured at digital output (in the dark)
Dynamic Range	59 dB	
Spectral Sensitivity Range	400 - 1000 nm	
Optical Cross Talk	15% 4%	To the first neighboring pixel To the second neighboring pixel
Power Dissipation	225 mW	Typical (including ADCs)

## Spectral Response Curve

Figure 2. Spectral Response Curve

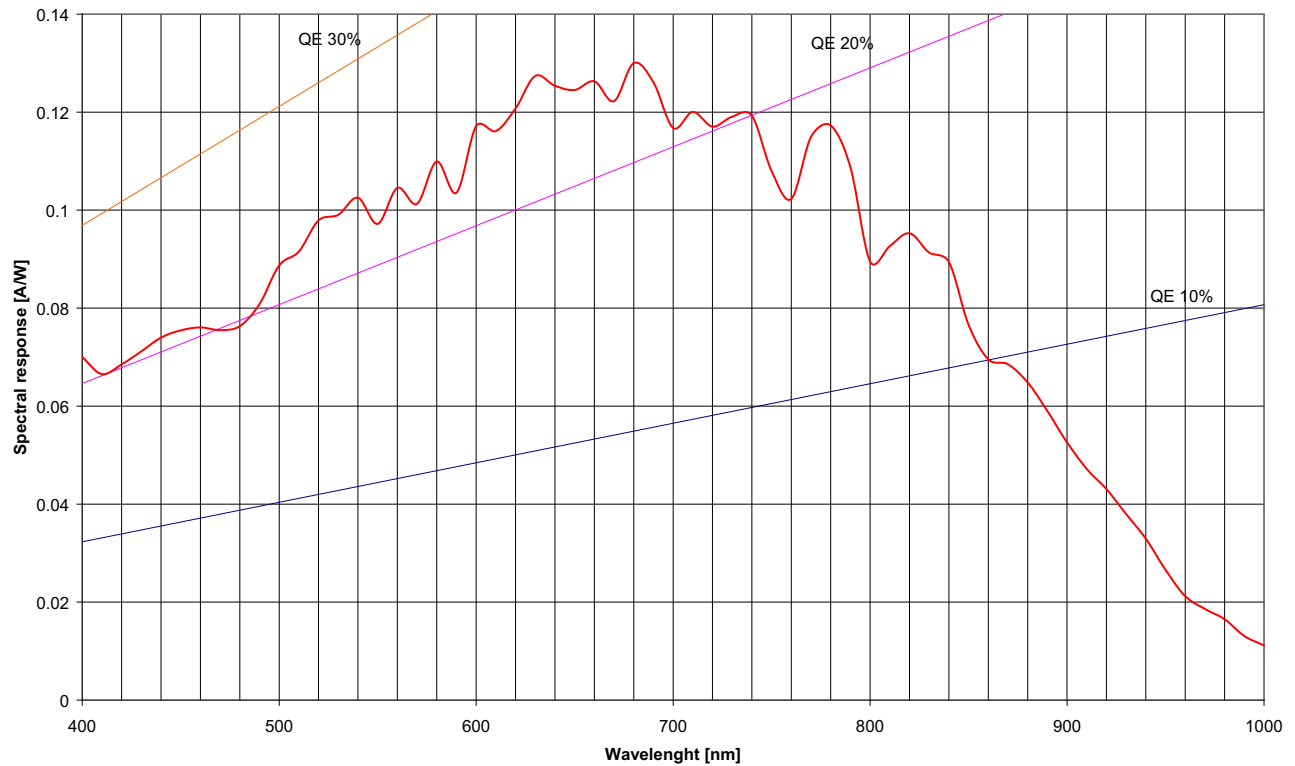

Figure 2 shows the characteristics of the spectral response. The curve is measured directly on the pixels. It includes the effects of nonsensitive areas in the pixel, for example, interconnection lines. The sensor is light sensitive between 400 and 1000 nm. The peak  $QE \times FF$  is 25% approximately 650 nm. In view of a fill factor of 35%, the QE is close to 70% between 500 and 700 nm.

## Electro Voltaic Response Curve

Figure 3. Electro Voltaic Response Curve

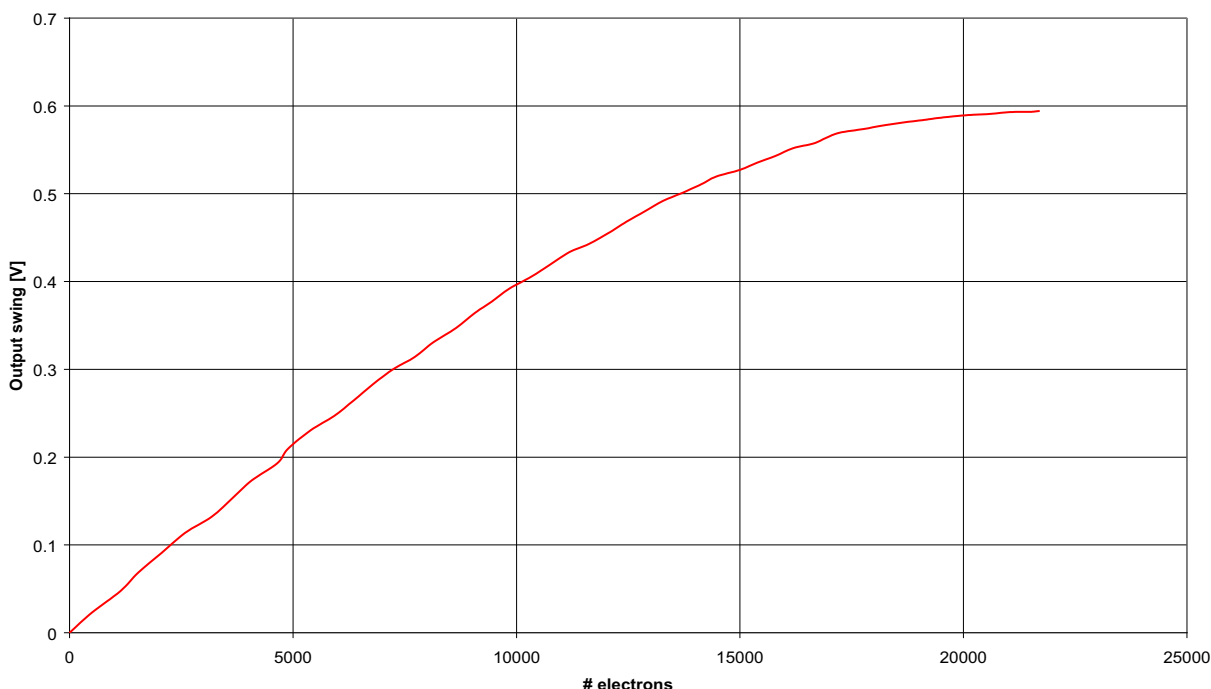

Figure 3 shows the pixel response curve in linear response mode. This curve is the relation between the electrons detected in the pixel and the output signal. The resulting voltage-electron curve is independent of any parameters, for example, integration time. The voltage to electrons conversion gain is  $43 \mu\text{V}/\text{electron}$ .

Table 1. Features and General Specifications

Feature	Specification/Description
Electronic shutter type	Rolling shutter
Integration time control	$60 \mu\text{s}$ - 1/frame period
Windowing (ROI)	Randomly programmable ROI read out
Sub Sampling Modes	Several sub sample modes can be programmed (refer Table 8 on page 12)
Extended Dynamic Range	Dual slope (up to 90 dB optical dynamic range) and nondestructive read out mode
Analog Output	The output rate of 40 Mpixels/s can be achieved with two analog outputs, each working at 20 Mpixel/s
Digital Output	Two on-chip 10-bit ADCs at 20 Msamples/s are multiplexed to one digital 10-bit output at 40 Msamples/s
Supply Voltage $V_{\text{DD}}$	Nominal 2.5V (some supplies require 3.3V for extended dynamic range)
Logic Levels	2.5V
Interface	Serial-to Parallel Interface (SPI)
Package	68-pins LCC

## Electrical Specifications

**Table 2. Recommended Operating Ratings<sup>[1,3]</sup>**

Symbol	Description	Min	Max	Units
T <sub>J</sub>	Operating temperature range	-30	65	°C
T <sub>S</sub>	Storage temperature range	20	40	°C
	Storage humidity range	30	60	%RH

**Table 3. Absolute Maximum Ratings<sup>[2], [3] [4]</sup>**

Symbol	Parameter	Min	Max	Unit
V <sub>DD</sub> <sup>[5]</sup>	DC Supply Voltage	-0.5	4.3	V
V <sub>IN</sub>	DC Input Voltage	-0.5	(V <sub>DD</sub> + 0.5)	V
V <sub>OUT</sub>	DC Output Voltage	-0.5	(V <sub>DD</sub> + 0.5)	V
T <sub>ST</sub>	Storage Temperature	-30	+85	°C
%RH	Humidity (Relative)	-	85% at 85 °C	
Electrostatic discharge (ESD) <sup>[3]</sup>	Human Body Model (HBM)	See Note 3		V
	Charged Device Model (CDM)			
LU <sup>[4]</sup>	Latch-up	See Note 4		mA

All parameters are characterized for DC conditions after thermal equilibrium is established. Unused inputs must always be tied to an appropriate logic level, for example, V<sub>DD</sub> or GND. The IBIS4-6600 is extremely susceptible to noise on the power supplies. In addition, it has no power supply filtering on chip. Therefore, all power supplies to the sensor must be clean with the target being to achieve a low noise (1 mV). Special attention must be given to the pixel supplies VPIX, GND\_AB, VRESET and VRESET\_DS.

**Table 4. Recommended DC Operating Conditions**

Parameter	Description	Typical Dynamic Currents	Min	Typ (V)	Max
VDD_PIX	V <sub>DD</sub> of pixel core		-5%	2.5V	5%
VDD_RESET	Reset voltage. Highest voltage to the chip. 3.3V for extended dynamic range or 'hard reset'		-5%	2.5V	3.3V
VDD_RESET_DS	Variable reset voltage (dual slope)		-5%	2.5V	5%
VDDA	V <sub>DD</sub> of analog supply	3mA	-5%	2.5V	5%
VDDA_ADC	Analog supply to the ADC	53mA	-5%	2.5V	5%
VDDAMP	V <sub>DD</sub> of analog output. (Can be connected to V <sub>DDA</sub> )	20mA	-5%	2.5V	5%
VDDD	V <sub>DD</sub> of digital supply	3mA	-5%	2.5V	5%
VDDD_ADC	Digital supply to the ADC	10mA	-5%	2.5V	5%

### Notes

- Operating ratings are conditions in which operation of the device is intended to be functional. All parameters are characterized for DC conditions after thermal equilibrium is established. Unused inputs must always be tied to an appropriate logic level, for example, VDD or GND.
- Stresses above these ratings may cause permanent damage. Exposure to absolute maximum conditions for extended periods may degrade device reliability. These are stress ratings only, and functional operation of the device at these or any other conditions beyond those specified is not implied.
- This device does NOT contain circuitry to protect the inputs against damage caused by high static voltages or electric fields. ON Semiconductor recommends that customers become familiar with, and follow the procedures in JEDEC Standard JESD625-A. Refer to Application Note AN52561.
- The IBIS4-6600 does not have latchup protection.
- V<sub>DD</sub> = V<sub>DDD</sub> = V<sub>DDA</sub> (V<sub>DDD</sub> is supply to digital circuit, V<sub>DDA</sub> to analog circuit).

## Sensor Architecture

### Floor Plan

Figure 4. Floor Plan

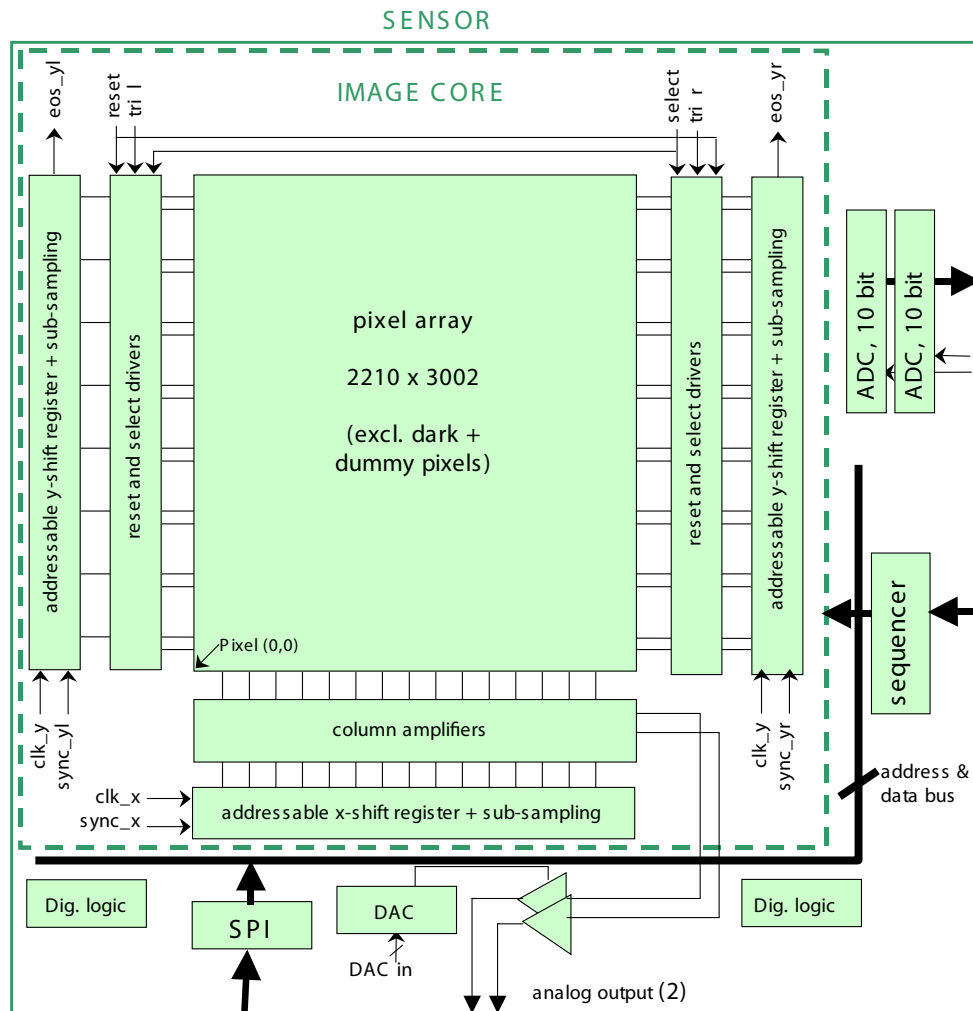

Figure 4 shows the architecture of the designed image sensor. It consists of the pixel array, shift registers for the readout in x and y direction, parallel analog output amplifiers, and column amplifiers that correct for the fixed pattern noise caused by threshold voltage nonuniformities. Reading out the pixel array starts by applying a y clock pulse to select a new row, followed by a calibration sequence to calibrate the column amplifiers (row blanking time). Depending on external bias resistors and timing, typically this sequence takes about seven seconds every line (baseline). This sequence is necessary to remove the Fixed Pattern Noise of the pixel and of the column amplifiers themselves (by a Double Sampling technique). Pixels can also be read out in a nondestructive manner.

Two DACs are added to make the offset level of the pixel values adjustable and equal for the two output buses. A third DAC is used to connect the buses to a stable voltage during the row blanking period, or reset the buses continuously in case of a nondestructive readout.

Two 10-bit ADCs running at 20 Msamples/s convert the analog pixel values. The digital outputs are multiplexed to one digital 10-bit output at 40 Msamples/s. Note that these blocks are electrically completely isolated from the sensor part, except for the multiplexer, for which the settings are uploaded through the shared address and data bus.

The x and y shift registers have a programmable starting point. The possibilities of the starting point are limited because of limitations imposed by subsampling requirements. The start address is uploaded through the serial to parallel interface.

Most of the signals for the image core shown in Figure 4 are generated on-chip by the sequencer. This sequencer also allows running the sensor in basic modes, not fully autonomous.

**Pixel**

*Architecture*

The pixel architecture is the classic three-transistor pixel, as shown in Figure 5. The pixel is implemented using the high fill factor technique patented by FillFactory (US patent No. 6,225,670 and others).

**Figure 5. 3T Pixel Architecture**

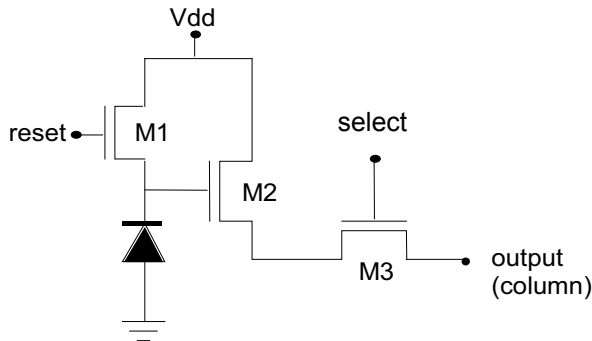

*FPN and PRNU*

Fixed Pattern Noise correction is done on-chip. Raw images taken by the sensor typically feature a residual (local) FPN of 0.35% RMS of the saturation voltage.

The Photo Response Non Uniformity (PRNU), caused by the mismatch of photodiode node capacitances, is not corrected on chip. Measurements indicate that the typical PRNU is about 1.5% RMS of the signal level.

*Dark and Dummy Pixels*

Figure 6 shows a plan of the pixel array. The sensor is designed in portrait orientation. A ring of dummy pixels surrounds the active pixels. Black pixels are implemented as "optical" black pixels.

**Figure 6. Floor Plan Pixel Array**

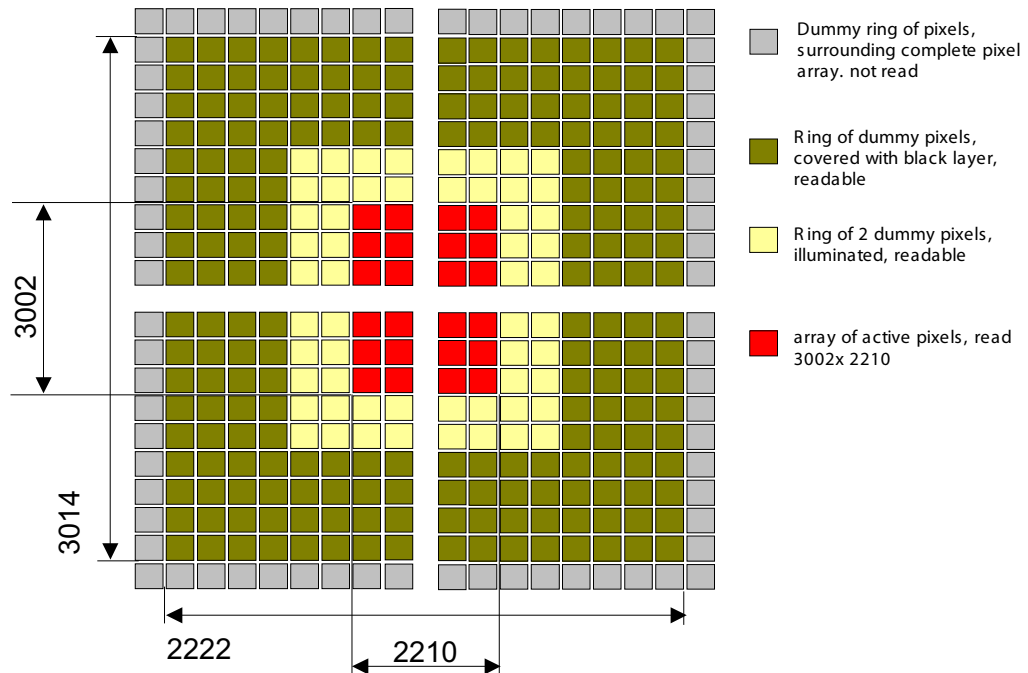

**Output Amplifier**

The output amplifier subtracts the reset and signal voltages from each other to cancel FPN as much as possible (shown in Figure 7). The DAC that is used for offset adjustment consists of two DACs. One DAC is used for the main offset (DAC\_raw). The other enables fine tuning to compensate the offset difference between the signal paths arriving at the two amplifiers A1 and A2 (DAC\_fine). With the analog multiplexer, the signals S1 and S2 from the two buses can be combined to one pixel output at full pixel rate (40 MHz). However, the two analog signals S1 and S2

can also be available on two separate output pins to allow a higher pixel rate.

The third DAC (DAC\_dark) puts its value on the buses during the calibration of the output amplifier. In case of nondestructive readout (no double sampling), bus1\_R and bus2\_R are continuously connected to the output of the DAC\_fine to provide a reference for the signals on bus1\_S and bus2\_S.



The complete output amplifier can be put in standby by setting the corresponding bit in the AMPLIFIER register.

**Figure 7. Output Amplifier Architecture**

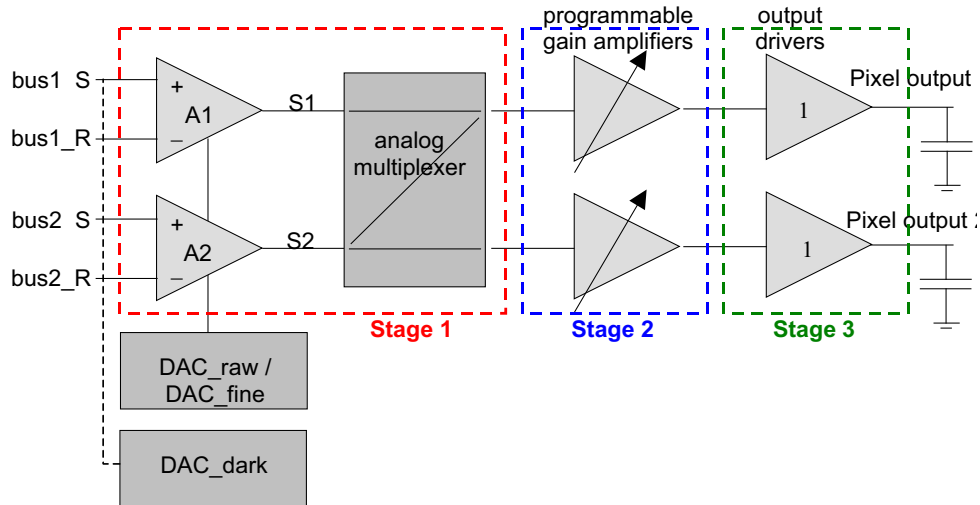

**Stage 1: Offset, FPN Correction, and Multiplexing**

In the first stage, the signals from the buses are subtracted and the offset from the DACs is added. After a system reset, the analog multiplexer is configured for two outputs (see the bit settings in the [AMPLIFIER Register](#) on page 22). In case ONE\_OUT is set to 1, the two signals S1 and S2 are multiplexed to one output (output 1). The amplifiers of Stage 2 and Stage 3 of the second output path are then put in standby. The speed and power consumption of the first stage can be controlled through the resistor connected to CMD\_OUT\_1.

**Stage 2: Programmable Gain Amplifier**

The second stage provides the gain, which is adjustable between 1.36 and 17.38 in steps of approximately 20.25 (~1.2). An overview of the gain settings is given in [Table 5](#). The speed and power consumption of the second stage can be controlled through the resistor connected to CMD\_OUT\_2.

**Table 5. PGA Gain Settings**

Bits	DC Gain	Bits	DC Gain
0000	1.36	1000	5.40
0001	1.64	1001	6.35

**Table 5. PGA Gain Settings**

Bits	DC Gain	Bits	DC Gain
0010	1.95	1010	7.44
0011	2.35	1011	8.79
0100	2.82	1100	10.31
0101	3.32	1101	12.36
0110	3.93	1110	14.67
0111	4.63	1111	17.38

**Stage 3: Output Drivers**

The speed and power consumption of the third stage can be controlled through the resistor connected to CMD\_OUT\_3. The output drivers are designed to drive a 20 pF output load at 40 Msamples/s with a bias resistor of 100 kΩ.

**Offset DACs**

[Figure 8](#) shows how the DAC registers influence the black reference voltages of the two different channels. The offset is mainly given through DAC\_raw. DAC\_fine can be used to shift the reference voltage of bus 2 up or down to compensate for different offsets in the two channels.

Figure 8. Offset for the Two Channels through DAC\_RAW and DAC\_FINE

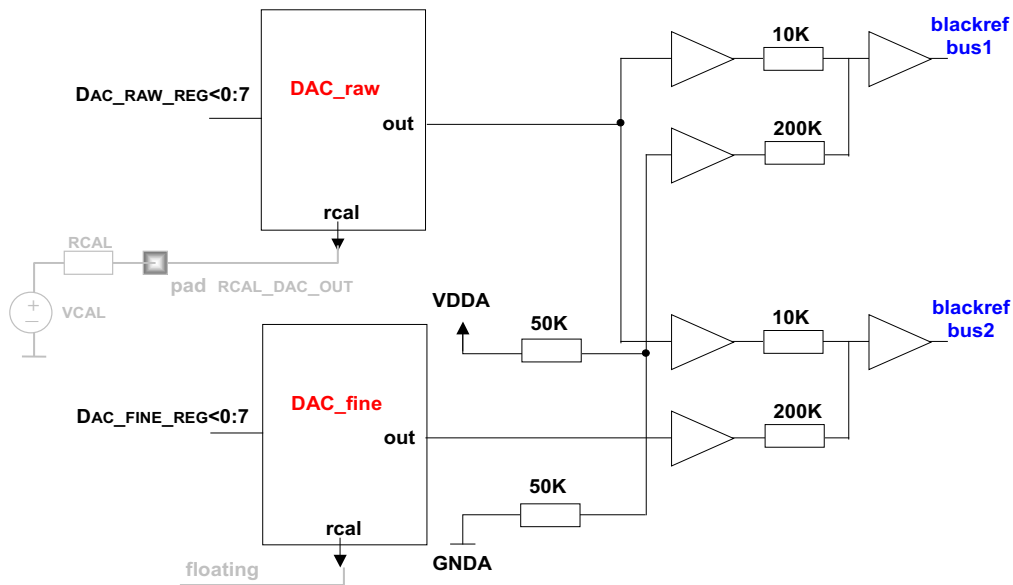

Note that in this figure, "K" represents KΩ.

Assume that  $V_{outfull}$  is the voltage that depends on the bit values that are applied to the DAC and ranges from:

$$V_{outfull} : 0 \text{ (bit values 00000000) } \rightarrow VDDA \left(1 - \frac{1}{2^8}\right) \text{ (bit values 11111111) }$$

Externally, the output range of DAC\_raw can be changed by connecting a resistor  $R_{cal}$  to RCAL\_DAC\_OUT and applying a voltage  $V_{cal}$ . The output voltage  $V_{out}$  of DAC\_raw follows the relation ( $R = 10 \text{ k}\Omega$ ).

$$V_{out} = \frac{R + R_{cal}}{2R + R_{cal}} V_{outfull} + \frac{R}{2R + R_{cal}} V_{cal}$$

Special case:

$R_{cal} = \text{"open"}$  (infinite resistance), then  $V_{out} = V_{outfull}$  (for example, for DAC\_fine)

$R_{cal} = 0 \text{ ohms "short"}$  and  $V_{cal} = \text{GND}$ , then  $V_{out} = V_{outfull}/2$

### Analog to Digital Converter

The IBIS4-6600 has a two 10-bit flash analog digital converters. The ADCs are electrically separated from the image sensor. The inputs of the ADC must be tied externally to the outputs of the output amplifiers. One ADC samples the even columns and the second ADC samples the odd columns. Alternatively, one ADC can also sample all the pixels.

The sensor's outputs are not designed to drive large loads. Therefore, to drive a cable or long PCB trace, the outputs of the sensor should be buffered.

**Table 6. ADC Specifications**

Parameter	Specification
Input Range	Set by External Resistors (Refer the section <a href="#">The internal resistance has a value of approximately 577 Ω. Only 277 Ω of this internal resistance is actually used as reference for the internal ADC.</a> )
Quantization	10 Bits
Nominal Data Rate	20 Msamples/s
DNL	Typical: 1.5 LSB10
INL	Typical: 5 LSB10
Input Capacitance	< 2 pF
Conversion Law	Linear/Gamma corrected

The internal resistance has a value of approximately 577 Ω. Only 277 Ω of this internal resistance is actually used as reference for the internal ADC.

#### Black Calibration

Due to slight variations in the chip fabrication process, the output analog voltage of the PGA is not perfectly matched to the input analog range of the ADC. As a result, a reduced dynamic range is obtained when comparing sensors/cameras from different lots.

This is especially true in the dark as it is possible that a part of the analog range gets clipped when it reaches the ADC.

For this reason, black calibration step is required. Because this is a fixed setting, and varies very slightly with temperature, the setting can be done at the factory itself.

While grabbing normal images, the settings can be loaded from an on-board memory.

In the IBIS4-6600 image sensor, black calibration step also tries to match the output of the odd and even channels.

The steps for black calibration are -

1. Put the sensor in dark.
2. Change DAC\_RAW such that no pixel or least number of pixels (assuming there are defect pixels) have a zero ADC output value.
3. Change DAC\_FINE such that the average of the odd columns is almost same as the even columns.
4. Change DAC\_RAW again such that all pixels have a non-zero output, but are as close to zero as possible.
5. Record the DAC\_RAW and DAC\_FINE values.
6. Load the recorded DAC register values during operation.

### Serial to Parallel Interface (SPI)

To upload the sequencer registers, a dedicated serial to parallel interface (SPI) is implemented. 16 bits (4 address bits + 12 data bits) must be uploaded serially. The address must be uploaded first (MSB first), then the data (also MSB first).

The elementary unit cell is shown in [Figure 9](#). Sixteen of these cells are connected in series, having a common SPI\_CLK from the entire uploadable parameter block. Dout of one cell is connected to SPI\_DATA of the next cell (maximum speed is 20 MHz). The uploaded settings on the address/data bus are loaded into the correct register of the sensor on the rising edge of signal REG\_CLOCK and become effective immediately.

**Figure 9. SPI Interface**

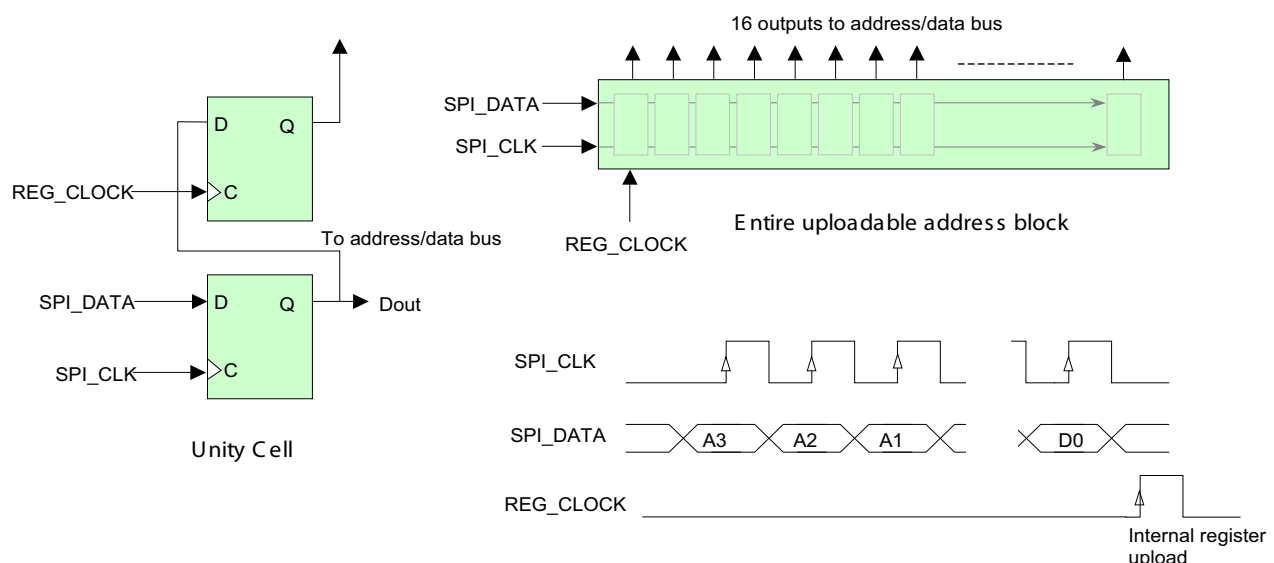

## Sensor Operation

### Pixel Rate

The pixel rate for this sensor is high enough to support a frame rate greater than 75 Hz for a window size of 640 x 480 pixels (VGA format). With a row blanking time of 7.2 μs (as baseline, refer the following calculations), requires a minimum pixel rate of approximately 40 MHz. The bandwidth of the column amplifiers, gain amplifiers and output stage are determined by external bias resistors. Taking into account a pixel rate of 40 MHz, a full frame rate of a little more than 5 frames/s is obtained

The frame period of the IBIS4-6600 sensor is calculated as:

$$\Rightarrow \text{Frame period} = (\text{Nr. Lines} * (\text{RBT} + \text{pixel period} * \text{Nr. Pixels}))$$

In this equation:

Nr. Lines: Number of Lines read out each frame (Y)

Nr. Pixels: Number of pixels read out each line (X)

RBT: Row Blanking Time = 7.2 μs (typical)

Pixel period: 1/40 MHz = 25 ns

Example: Read out time of the full resolution at nominal speed (40 MHz pixel rate):

$$\Rightarrow \text{Frame period} = (3002 * (7.2 \mu\text{s} + 25 \text{ ns} * 2210)) = 187.5 \text{ ms} \\ \Rightarrow 5.33 \text{ fps.}$$

### Region of Interest (ROI) Read Out

Windowing is easily achieved by uploading the starting point of the x and y-shift registers in the sensor registers (refer Table 11 on page 17). This downloaded starting point initiates the shift register in the x and y-direction, triggered by the Y\_START (initiates the Y-shift register) and the Y\_CLK (initiates the X-shift register) pulse. The minimum step size for the X-address and Y-address is 24 pixels. The frame rate increases in an almost linear manner when fewer pixels are read out. Table 7 lists the achievable frame rates with ROI read out.

**Table 7. Frame Rate vs. Resolution**

Image Resolution (Y*X)	Frame Rate [frames/s]	Frame Readout Time [ms]	Comment
3002 x 2210	5	187.5	Full resolution
1501 x 1104	14	67	ROI read out
640 x 480	89	11	11

### Subsampling Modes

To increase the frame rate for lower resolution and regions of interest, several sub sampling modes are implemented. The possible sub sample modes are listed in Table 8. The bits can be programmed in the IMAGE\_CORE register (refer Table 11 on page 17). Two adjacent pixels are read in any mode. The number of pixels that is not read varies from mode to mode. This is designed as a repeated block 24 pixels wide, which is the lowest common multiple of the modes described. Including the dummy pixels and the two additional rows/columns, the number of starting coordinates for the x and y shift register is 99 in the X direction and 138 in the Y direction. The total number of pixels, excluding dummy pixels, is a multiple of 24, and two additional pixels to have the same window edges independently of the sub sampling mode.

In the X direction, two columns are always addressed at the same moment, because the signals from the odd and even columns must be put simultaneously on the corresponding bus. In the Y direction, the rows are addressed one by one. This results in slightly different implementations of the sub-sampling modes for the two directions (Refer Figure 10 and Figure 11 on page 14).

**Table 8. Subsample Patterns**

Mode	Bits	Read	Step	Description
A	000	2	2	Default mode
B	001	2	4	(Skip 2)
C	010	2	6	(Skip 4)
D	011	2	8	(Skip 6)
E	1xx	2	12	(Skip 10)

Figure 10. X-Sub Sampling

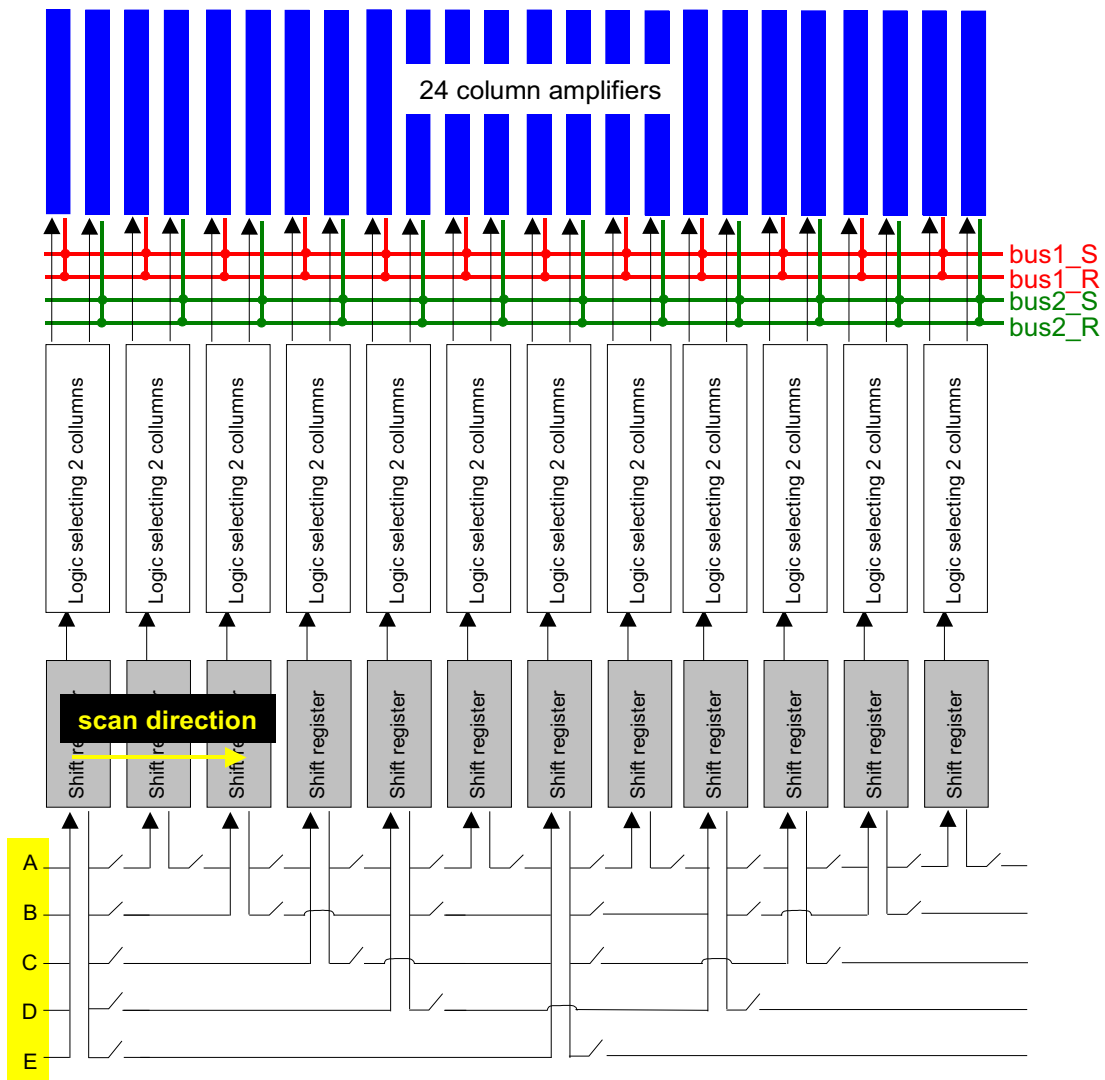

Figure 11. Y-Sub Sampling

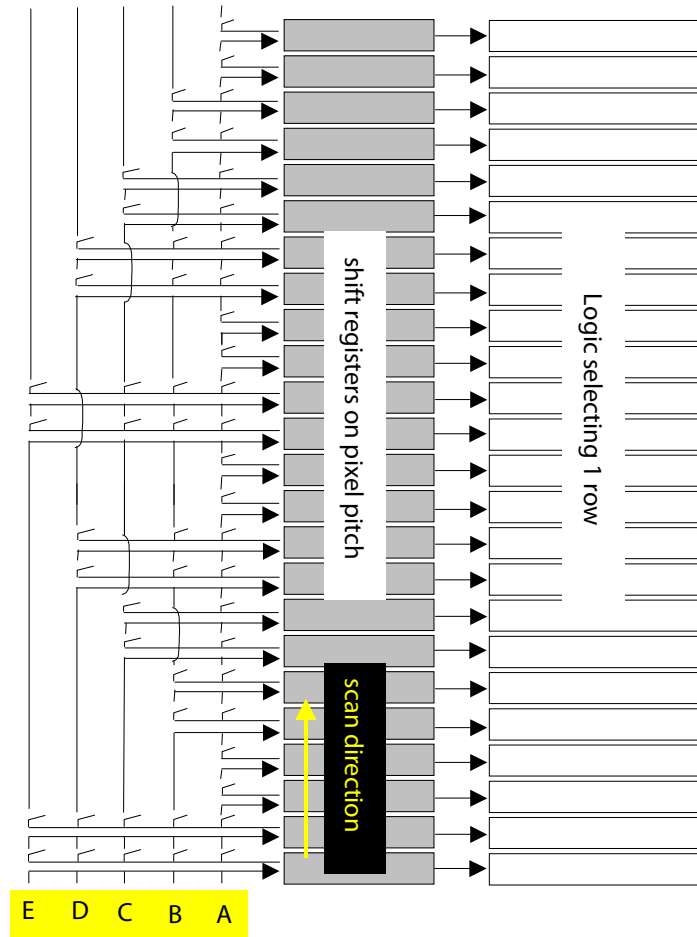

Table 9. Frame Rate vs. Sub Sample Mode

Mode	Ratio	Resolution (Y*X)	Frame time [mS]	Frame time [mS]
A	1:1	3002 x 2210	187.4	5.3
B	1:4	1502 x 1106	52.3	19.1
C	1:9	1002 x 738	25.7	38.9
D	1:16	752 x 554	15.8	63.2
63.2	1:36	502 x 370	8.2	121.2
VGA (p)		640 x 480	12.3	81.5
VGA (p) + 23		663 x 503	13.1	76.4
VGA (l)		480 x 640	11.1	89.9
VGA(l) + 23		503 x 663	11.9	83.7

### Electronic Shutter

An electronic shutter similar to a rolling curtain is implemented on-chip. As shown in Figure 13, there are two Y shift registers. One shift register points to the row that is currently being read out. The other shift register points to the row that is currently being reset. Both pointers are shifted by the same Y-clock and move over the focal plane. The integration time is set by the delay between both pointers.

Figure 12. Electronic Shutter

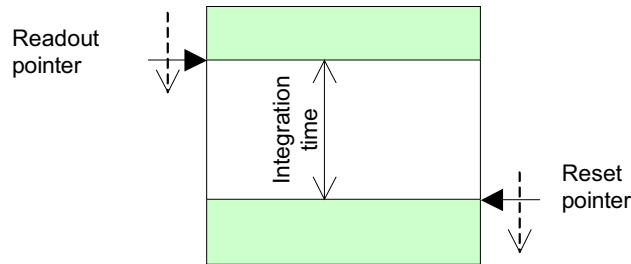

In case of a mechanical shutter, the two shift registers can be combined to simultaneously apply the pulses from both sides of the pixel array. This is to halve the influence of the parasitic RC times of the reset and select lines in the pixel array. This can result in a reduction of the row blanking time. This is the case when FAST\_RESET in the SEQUENCER register is set to 1, or in the nondestructive readout modes 1 and 2.

Figure 13. Electronic Rolling Shutter Operation

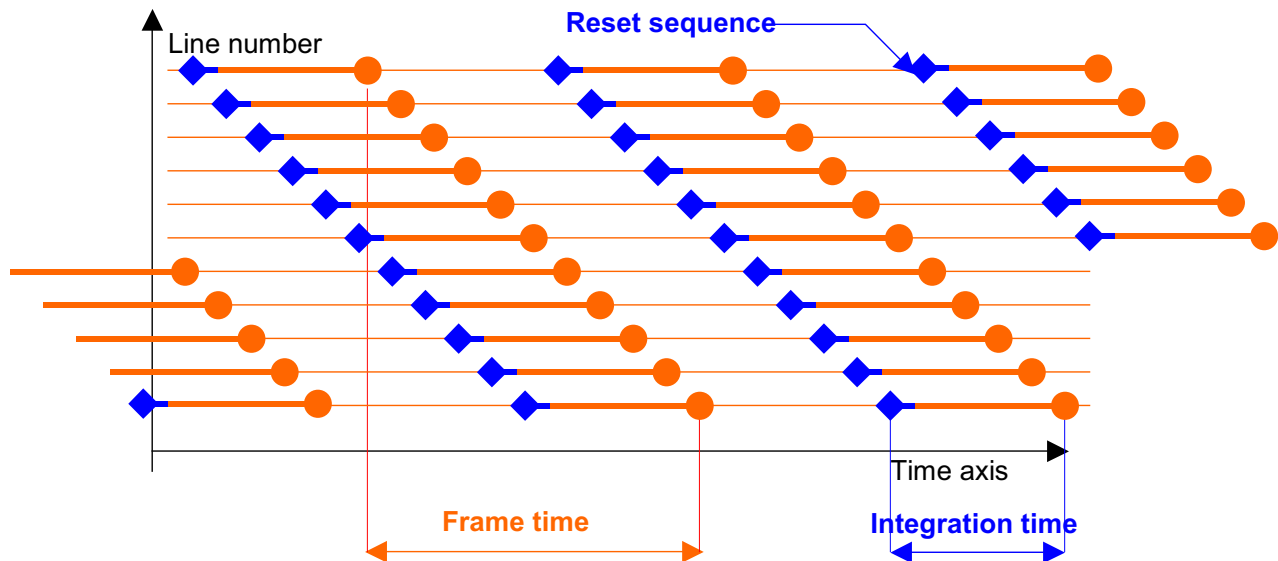

## High Dynamic Range Modes

### Double Slope Integration

The IBIS4-6600 has a feature called double slope integration to increase the optical dynamic range of the sensor. The pixel response can be extended over a larger range of light intensities by using a "dual slope integration". This is obtained by adding charge packets from a long and a short integration time in the pixel during the same exposure time. Figure 14 shows the response curve of a pixel in dual slope integration mode. The curve also shows the response of the same pixel in linear integration mode at the same light levels, with a long and short integration time.

Dual slope integration is obtained by feeding a lower supply voltage to VDD\_RESET\_DS (for example, apply 2.0V). Note that for normal (single slope) operation, VDD\_RESET\_DS must have

the same value as VDD\_RESET. The difference between VDD\_RESET\_DS and VDD\_RESET determines the range of the high sensitivity, and as a result the output signal level at which the transition between high and low sensitivity occurs.

Put the amplifier gain to the lowest value where the analog output swing covers digital input swing of the ADC. Increasing the amplification too much may boost the high sensitivity part over the whole ADC range.

The electronic shutter determines the ratio of integration times of the two slopes. The high sensitivity ramp corresponds to "no electronic shutter", thus maximal integration time (frame read out time). The low sensitivity ramp corresponds to the electronic shutter value that is obtained in normal operation.

Figure 14. Double Slope Response

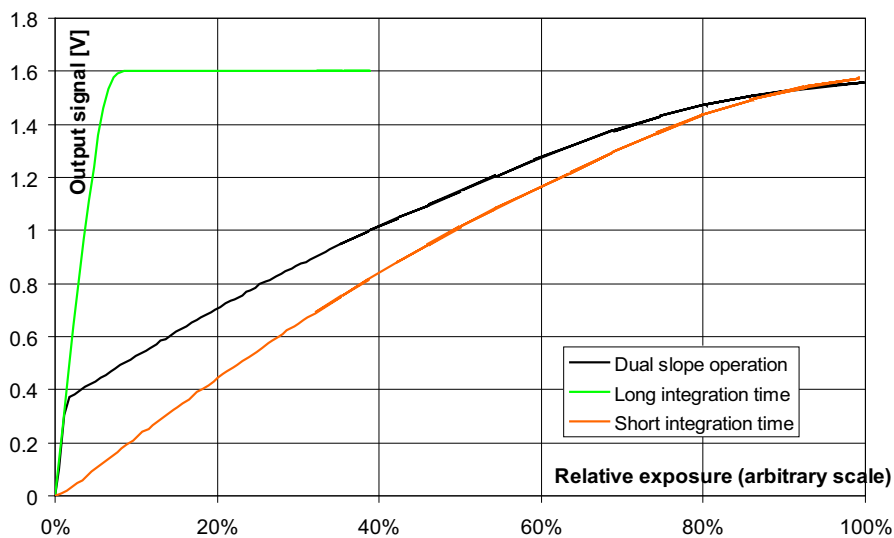

### NonDestructive Read Out (NDR)

The default mode of operation of the sensor is with FPN correction (double sampling). However, the sensor can also be read out in a nondestructive method. After a pixel is initially reset, it can be read multiple times, without being reset. The initial reset level and all intermediate signals can be recorded. High light levels saturate the pixels quickly, but a useful signal is obtained from the early samples. For low light levels, use the later or latest samples. Essentially an active pixel array is read multiple times, and reset only once. The external system intelligence interprets the data. Table 10 on page 17 summarizes the advantages and disadvantages of nondestructive readout.

Figure 15. Principle of NonDestructive Readout

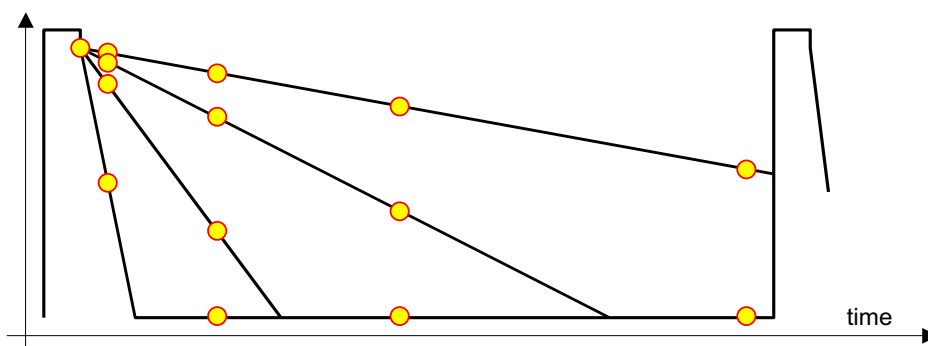



**Table 10. NDR: Advantages and Disadvantages**

Advantages	Disadvantages
Low Noise, because it is true CDS. In the order of 10 e- or below.	System memory required to record the reset level and the intermediate samples.
High Sensitivity, because the conversion capacitance is kept rather low.	Requires multiples readings of each pixel, thus higher data throughput.
High Dynamic Range, because the results include signals for short and long integrations times.	Requires system level digital calculations.

## Sequencer and Registers

Figure 4 on page 7 showed several control signals that are needed to operate the sensor in a particular sub sampling mode, with a certain integration time, output amplifier gain, and more. Most of these signals are generated on-chip by the sequencer that uses only a few control signals. These control signals must be generated by the external system:

- SYS\_CLOCK, which defines the pixel rate (nominal 40 MHz),
- Y\_START pulse, which indicates the start of a new frame,
- Y\_CLOCK, which selects a new row and starts the row blanking sequence, including the synchronization and loading of the X-register.

The relative position of the internal pulses is determined by a number of data bits that are uploaded in internal registers through a Serial to Parallel interface (SPI).

### Internal Registers

Table 11 lists the internal registers with a short description. The registers are discussed in more detail in the following sections.

On power-on, all the internal register of the IBIS4-6600 are reset to 0. All the sensor registers must to be loaded before the sensor is brought out of reset.

**Table 11. List of Internal Registers**

Register	Bit	Name	Description
0 (0000)	11:0	SEQUENCER register	Selection of mode, granularity of the X sequencer clock, calibration, Default value <11:0>:"000100000000"
	0	NDR	Mode of readout: NDR = 0: normal readout (double sampling) NDR = 1: non-destructive readout
	1:2	NDR_mode	4 different modes of nondestructive readout (no influence if NDR = 0)
	3	RESET_BLACK	0 = normal operation 1 = reset of pixels before readout
	4	FAST_RESET	0 = electronic shutter operation 1 = addressing from both sides
	5	FRAME_CAL_MODE	0 = fast 1 = slow
	6	LINE_CAL_MODE	0 = fast 1 = slow
	7	CONT_CHARGE	0 = normal mode 1 = continuous precharge
	8	GRAN_X_SEQ_LSB	Granularity of the X sequencer clock
	9	GRAN_X_SEQ_MSB	
	10	BLACK	0 = normal mode 1 = disconnects column amplifiers from buses, output of amplifier equals dark reference level
	11	RESET_ALL	0 = normal mode 1 = continuous reset of all pixels
1 (0001)	10:0	NROF_PIXELS	Number of pixels to count (X direction). Max. 2222/2 (2210 real + 12 dummy pixels). Default value <10:0>:"01000000000"

Table 11. List of Internal Registers (continued)

Register	Bit	Name	Description
2 (0010)	11:0	NROF_LINES	Number of lines to count (Y direction) Max. 3014 (3002 real + 12 dummy pixels) Default value <11:0>:"101111000110"
3 (0011)	11:0	INT_TIME	Integration time Default value <11:0>:"000000000001"
4 (0100)	7:0	DELAY	Delay of sequencer pulses Default value <7:0>:"00000011"
	0:3	DELAY_PIX_VALID	Delay of PIX_VALID pulse
	4:7	DELAY_EOL/EOF	Delay of EOL/EOF pulses
5 (0101)	6:0	X_REG	X start position (0 to 98) Default value <6:0>:"0000000"
6 (0110)	7:0	Y_REG	Y start position (0 to 137) Default value <7:0>:"00000000"
7 (0111)	7:0	IMAGE CORE register	Default value <7:0>:"00000000"
	1:0	TEST_mode	LSB: odd, MSB: even 0 = normal operation
	4:2	X_SUBSAMPLE	sub sampling mode in X-direction
	7:5	Y_SUBSAMPLE	sub sampling mode in X-direction
8 (1000)	9:0	AMPLIFIER register	Default value <9:0>:"0000010000"
	3:0	GAIN<3:0>	Output amplifier gain setting
	4	UNITY	0 = gain setting by GAIN<3:0> 1 = unity gain setting
	5	ONE_OUT	0 = two analog outputs 1 = multiplexing to one output (out_1)
	6	STANDBY	0 = normal operation 1 = amplifier in standby mode
	7:9	DELAY_CLK_AMP	Delay of pixel clock to output amplifier
9 (1001)	7:0	DAC_RAW_REG	Amplifier DAC raw offset Default value <7:0>:"10000000"
10 (1010)	7:0	DAC_FINE_REG	Amplifier DAC fine offset Default value <7:0>:"10000000"
11 (1011)	7:0	DAC_DARK_REG	DAC dark reference on output bus Default value <7:0>:"10000000"

**Table 11. List of Internal Registers** (continued)

Register	Bit	Name	Description
12 (1100)	10:0	ADC register	Default value <10:0>:"00000000000"
	0	STANDBY_1	0 = normal operation 1 = ADC in standby
	1	STANDBY_2	
	2	ONE	0 = multiplexing of two ADC outputs 1 = disable multiplexing
	3	SWITCH	if ONE = 0: delay of output with one (EXT_CLK = 0) or half (EXT_CLK = 1) clock cycle if ONE = 1: switch between two ADCs
	4	EXT_CLK	0 = internal clock (same as clock to X shift register and output amplifier) 1 = external clock
	5	TRISTATE	0 = normal operation 1 = outputs in tristate mode
	6:8	DELAY_CLK_ADC	Delay of clock to ADCs and digital multiplexer
	9	GAMMA	0 = linear conversion 1 = 'gamma' law conversion
	10	BITINVERT	0 = no inversion of bits 1 = inversion of bits
13 (1101)		Reserved	
14 (1110)		Reserved	
15 (1111)		Reserved	

**Description of Registers**

*SEQUENCER Register*

**a. NDR (Bit 0)**

In normal operation (NDR = 0), the sensor operates in double sampling mode. At the start of each row readout, the signals from the pixels are sampled, the row is reset, and the signals from the pixels are sampled again. The values are subtracted in the output amplifier.

When NDR is set to 1, the sensor operates in nondestructive readout (NDR) mode (refer [Table 12](#)).

**b. NDR\_mode (Bit 1 and 2)**

These bits only influence the operation of the sensor in case NDR (bit 0) is set to 1. There are two modes for nondestructive readout (mode 1 and 2). Each mode needs two different frame readouts (setting 1 and 2 for mode 1, setting 3 and 4 for mode 2). a reset/readout sequence (reset\_seq) and then one or several pure readout sequences (called read\_seq hereafter). [Table 12](#) gives an overview of the different NDR modes.

**Table 12. Overview of NDR Modes.**

Setting	Bits	NDR mode	Sequence
1	00	1	reset
2	01	1	read
3	10	2	reset

**Table 12. Overview of NDR Modes.**

Setting	Bits	NDR mode	Sequence
4	11	2	read

*Mode 1*

In this mode, the sensor is readout in the same method as for the nondestructive readout. However, electronic shutter control is not possible in this case, that is, the minimal (integration) time between two readings is equal to the number of lines that has to be read out (frame read time). The row lines are clocked simultaneously (left and right clock pulses are equal).

*Mode 2*

In this mode, it is possible to have a shorter integration time than the frame read time. Rows are alternatingly read out with the left and right pointer. These two pointers can point to two different rows (see INT\_TIME register). The integration time between two readings of the same row is equal to the number of lines that is set in the INT\_TIME register multiplied by 2 plus 1, and is the minimal one line read time.

In setting 3, the row that is read out by the left pointer is reset and read out (first Y\_CLOCK), and the row that is read out by the right pointer is read out without being reset (second Y\_CLOCK).

In setting 4, both rows are read out without being reset (on the first Y\_CLOCK the row is read out by the left pointer; on the second Y\_CLOCK the row is read out by the right pointer).

**c. Reset\_black (Bit 3)**

If RESET\_BLACK is set to 1, each line is reset before it is read out (except for the row that is read out by the right pointer in NDR Mode 2). This may be useful to obtain black pixels.

**d. Fast\_reset (Bit 4)**

The fast reset option (FAST\_RESET = 1) might be useful in case a mechanical camera shutter is used. The fast reset is done on a row-by-row basis, not by a global reset. A global reset means charging all the pixels at the same time, which may result in a huge peak current. Therefore, the rows can be scanned rapidly while the left and right shift registers are both controlled identically, so that the reset lines over the pixel array are driven from both sides. This reduces the reset (row blanking) time (when FAST\_RESET = 1 the smallest X-granularity can be used). After the row blanking time, the row is reset and Y\_CLOCK can be asserted to reset the next row.

After a certain integration time, the read out can be done in a similar method. The Y shift registers are again synchronized to the first row. Both shift registers are driven identically, and all rows and columns are scanned for (destructive) readout. FAST\_RESET = 1 puts the sequencer in such mode that the left and right shift registers are both controlled identically.

**e. Output Amplifier Calibration (Bit 5 and 6)**

Bits FRAME\_CAL\_MODE and LINE\_CAL\_MODE define the calibration mode of the output amplifier.

During every row-blanking period, a calibration is done of the output amplifier. There are two calibration modes. The FAST mode (= 0) can force a calibration in one cycle. However, it is not

accurate and suffers from kTC noise, while the SLOW mode (= 1) can only make incremental adjustments and is noise free. Approximately 200 or more "slow" calibrations have the same effect as one "fast" calibration.

Different calibration modes can be set at the beginning of the frame (FRAME\_CAL\_MODE bit) and for every subsequent row that is read (LINE\_CAL\_MODE bit).

**f. Continuous Charge (Bit 7)**

For some applications, it might be necessary to use continuous charging of the pixel columns instead of a precharge on every row sample operation.

Setting bit CONT\_CHARGE to 1 activates this function. The resistor connected to pin CMD\_COL is used to control the current level on every pixel column.

**g. Internal Clock Granularities**

The system clock is divided several times on-chip.

The X-shift-register that controls the column/pixel readout, is clocked by half the system clock rate. Odd and even pixel columns are switched to two separate buses. In the output amplifier, the pixel signals on the two buses can be combined to one pixel stream at 40 MHz.

The clock that drives the X-sequencer can be a multiple of 2, 4, 8, or 16 times the system clock. Table 13 lists the settings for the granularity of the X-sequencer clock and the corresponding row blanking time (for NDR = 0). A row blanking time of 7.18 μs is the baseline for almost all applications.

**Table 13. Granularity of X-Sequencer Clock and Corresponding Row Blanking Time (for NDR = 0).**

Gran_x_seq_msb/lsb	X-Sequencer Clock	Row Blanking Time	Row Blanking Time [μs]
00	2 x sys_clock	142 x TSYS_CLOCK	3.55
01	4 x sys_clock	282 x TSYS_CLOCK	7.05
10	8 x sys_clock	562 x TSYS_CLOCK	14.05
11	16 x sys_clock	1122 x TSYS_CLOCK	28.05

**h. Black (Bit 10)**

If BLACK is set to 1, the internal black signal is held high continuously. As a result, the column amplifiers are disconnected from the buses, and the buses are set to the voltage given by DAC\_DARK. The output of the amplifier equals the voltages from the offset DACs.

**i. Reset\_all (Bit 11)**

If RESET\_ALL is set to 1, all the pixels are simultaneously put in a 'reset' state. In this state, the pixels behave logarithmically with light intensity. If this state is combined with one of the NDR modes, the sensor can be used in a nonintegrating, logarithmic mode with high dynamic range.

**j. Nrof\_pixels Register**

After the internal X\_SYNC is generated (start of the pixel readout of a particular row), the PIXEL\_VALID signal goes high. The PIXEL\_VALID signal goes low when the pixel counter reaches the value loaded in the NROF\_PIXEL register and an EOL pulse is generated. Due to the fact that two pixels are addressed at each internal clock cycle, the amount of pixels read out in one row is 2\*(NROF\_PIXEL + 1).

**k. Nrof\_lines Register**

After the internal YL\_SYNC is generated (start of the frame readout with Y\_START), the line counter increases with each Y\_CLOCK pulse until it reaches the value loaded in the NROF\_LINES register and an EOF pulse is generated. In NDR Mode 2, the line counter increments only every two Y\_CLOCK pulses and the EOF pulse shows up only after the readout of the row indicated by the right shift register

*INT\_TIME Register*

When the Y\_START pulse is applied (start of the frame readout), the sequencer generates the YL\_SYNC pulse for the left Y-shift register. This loads the left Y-shift register with the pointer loaded in Y\_REG register. At each Y\_CLOCK pulse, the pointer shifts to the next row and the integration time counter increases (increment only every two Y\_CLOCK pulses in NDR mode 2) until it reaches the value loaded in the INT\_TIME register. At that moment, the YR\_SYNC pulse for the right Y-shift register is generated, which loads the right Y-shift register with the pointer loaded in Y\_REG register (shown in Figure 16 on page 21).

Figure 16. Syncing of Y-shift Registers

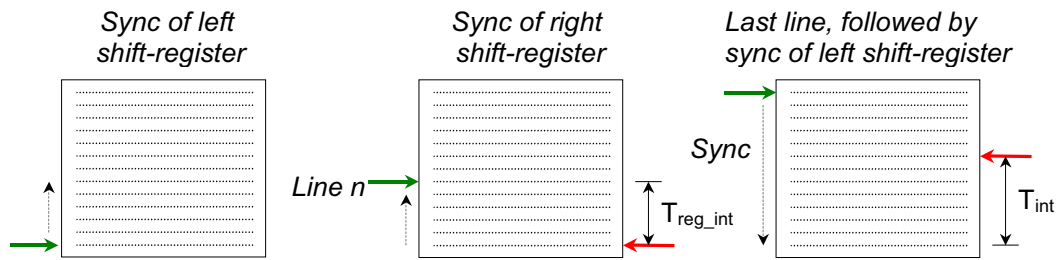

Treg\_int: Difference between left and right pointer = integration counter until value in INT\_TIME register is reached = INT\_TIME register

In case of NDR = 0, the actual integration time Tint is given by

TintL: Integration time [# lines] = NROF\_LINES register - INT\_TIME register + 1

In case of NDR = 1, NDR mode 1, the time Tint between two readings of the same row is given by:

Tint: Integration time [# lines] = NROF\_LINES register + 1

In case of NDR = 1, NDR mode 2, the times Tint1 and Tint2 between two readings of the same row (alternatingly) are given by:

Tint1: Integration time [# lines] = 2 \* INT\_TIME register + 1

Tint2: Integration time [# lines] = 2 \* (NROF\_LINES register + 1) - (2 \* INT\_TIME register + 1)

**DELAY Register**

The DELAY register can be used to delay the PIXEL\_VALID pulse (bits 0:3) and the EOL/EOF pulses (bits 4:7) to synchronize them to the real pixel values at the analog output or the ADC output (which give additional delays depending on their settings). The bit settings and corresponding delay are indicated in Table 14.

Table 14. Added Delay by Changing the DELAY Register Settings

Bits	Delay [# SYS_CLOCK periods]	Bits	Delay [# SYS_CLOCK periods]
0000	0	1000	6
0001	0	1001	7
0010	0	1010	8
0011	1	1011	9
0100	2	1100	10
0101	3	1101	11
0110	4	1110	12
0111	5	1111	13

**X\_REG Register**

The X\_REG register determines the start position of the window in the X-direction. In this direction, there are 2208 + 2 + 12 readable pixels. In the active pixel array, sub sampling blocks are 24 pixels wide and the columns are read two by two. Therefore, the number of start positions equals 2208/24 + 2/2 + 12/2 = 92 + 1 + 6 = 99.

**Y\_REG Register**

The Y\_REG register determines the start position of the window in the Y-direction. In this direction, there are 3000 + 2 + 12 readable pixels. In the active pixel array, sub sampling blocks are 24 pixels wide and the rows are read one by one. Therefore, the

number of start positions equals 3000/24 + 2/2 + 12 = 125 + 1 + 12 = 138.

**Image\_core Register**

Bits 0:1 of the IMAGE\_CORE register defines the several test modes of the image core. Setting 00 is the default and normal operation mode. If the bit is set to 1, the odd (bit 0) or even (bit 1) columns are tight to V<sub>DD</sub>. These test modes can be used to tune the sampling point of the ADCs to an optimal position.

Bits 2:7 of the IMAGE\_CORE register define the sub sampling mode in the X-direction (bits 2:4) and in the Y-direction (bits 5:7). The sub sampling modes and corresponding bit setting are shown in "Subsampling Modes" on page 12.

*AMPLIFIER Register*

**a. Gain (Bits 0:3)**

The gain bits determine the gain setting of the output amplifier. They are effective only if UNITY = 0. The gains and corresponding bit setting are given in Table 5 on page 9.

**b. Unity (Bit 4)**

If UNITY = 1, the gain setting of GAIN is bypassed and the gain amplifier is put in unity feedback.

**c. One\_out**

If ONE\_OUT = 0, the two output amplifiers are active. If ONE\_OUT = 1, the signals from the two buses are multiplexed to output OUT1. The gain amplifier and output driver of the second path are put in standby.

**d. Standby**

If STANDBY = 1, the complete output amplifier is put in standby. This reduces the power consumption significantly.

**e. Delay\_clk\_amp**

The clock that acts on the output amplifier can be delayed to compensate for any delay that is introduced in the path from shift register, column selection logic, column amplifier, and buses to the output amplifier. Setting '000' is used as a baseline.

**Table 15. Added Delay by Changing the DELAY\_CLK\_AMP Bit Settings**

Bits	Delay [ns]	Bits	Delay [ns]
000	1.7	100	Inversion + 8.3
001	2.9	2.9	Inversion + 9.7
010	4.3	110	Inversion + 11.1
011	6.1	111	Inversion + 12.3

*Dac\_raw\_reg and Dac\_fine\_reg Register*

These registers determine the black reference level at the output of the output amplifier. Bit setting 11111111 for DAC\_RAW\_REG register gives the highest offset voltage; bit setting 00000000 for DAC\_RAW\_REG register gives the lowest offset voltage. Ideally, if the two output paths have no offset mismatch, the DAC\_FINE\_REG register must be set to 10000000. Deviation from this value can be used to compensate the internal mismatch (see the section [Offset DACs](#) on page 9).

*Dac\_raw\_dark Register*

This register determines the voltage level that is put on the internal buses during calibration of the output stage. This voltage level is also continuously put on the reset buses in case of nondestructive readout (as a reset level for the double sampling FPN correction).

*ADC Register*

**a. Standby\_1 and standby\_2**

If only one or none of the ADCs is used, the other or both ADCs can be put in standby by setting the bit to 1. This significantly reduces the power consumption.

**b. One**

If OUT1 and OUT2 are both used and connected to ADC\_IN1 and ADC\_IN2 respectively, ONE must be 0 to use both ADCs and to multiplex their output to ADC\_D<9:0>. If ONE = 1, the multiplexing is disabled.

**c. Switch**

If the two ADCs are used (ONE = 0) and internal pixel clock (EXT\_CLK = 0), the ADC output is delayed with one system clock cycle if SWITCH = 1. If the two ADCs are used (ONE = 0) and an external ADC clock (EXT\_CLK = 1) is applied, the ADC output is delayed with half ADC clock cycle if SWITCH = 1.

If only one ADC is used, the digital multiplexing is disabled by ONE = 1, but SWITCH selects which ADC output is on ADC\_D<9:0> (SWITCH = 0: ADC\_1, SWITCH = 1: ADC\_2).

**d. Ext\_clk**

If EXT\_CLK = 0, the internal pixel clock (that drives the X-shift registers and output amplifier, that is, half the system clock) is used as input for the ADC clock. If EXT\_CLK = 1, an external clock must be applied to pin ADC\_CLK\_EXT (pin 46).

**e. Tristate**

If TRISTATE = 1, the ADC\_D<9:0> outputs are in tri-state mode.

**f. Delay\_clk\_adc**

The clock that finally acts on the ADCs can be delayed to compensate for any delay introduced in the path from the analog outputs to the input stage of the ADCs. The same settings apply for the delay that can be given to the clock acting on the output amplifier (see Table 15). The best setting also depends on the delay of the output amplifier clock and the load of the output amplifier. It must be used to optimize the sampling moment of the ADCs with respect to the analog pixel input signals. Setting '000' is used as a baseline.

**g. Gamma**

If GAMMA is set to 0, the ADC input to output conversion is linear, otherwise the conversion follows a 'gamma' law (more contrast in dark parts of the window, lower contrast in the bright parts).

**h. Bitinvert**

If BITINVERT = 0, 000000000 is the conversion of the lowest possible input voltage, otherwise the bits are inverted.

## Timing Diagrams

### Sequencer Control Signals

There are 3 control signals that operate the image sensor:

- SYS\_CLOCK
- Y\_CLOCK
- Y\_START

These control signals must be generated by the external system with the following time constraints to SYS\_CLOCK (rising edge = active edge):

- TSETUP > 7.5 ns
- THOLD > 7.5 ns

It is important that these signals are free of any glitches.

**Figure 17. Relative Timing of the Three Control Signals**

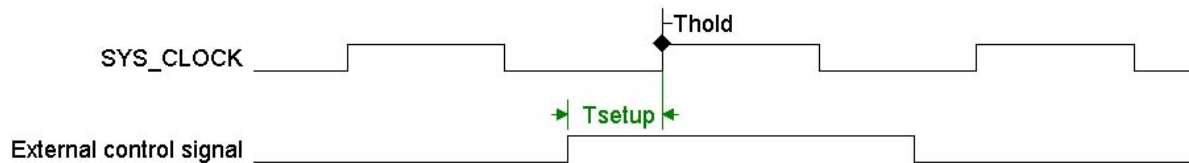

### Basic Frame and Line Timing

The basic frame and line timing of the IBIS4-6600 sensor is shown in [Figure 18](#).

The pulse width of Y\_CLOCK must be a minimum of one clock cycle and three clock cycles for Y\_START. As long as Y\_CLOCK is applied, the sequencer stays in a suspended state.

- T1 Row blanking time: During this period, the X-sequencer generates the control signals to sample the pixel signal and pixel reset levels, and start the readout of one line. It depends on the granularity of the X-sequencer clock (see [Table 13](#) on page 20).
- T2 Pixels counted by pixel counter until the value of Nrof\_pixels register is reached. Pixel\_valid goes high when the internal X\_sync signal is generated. In other words, when the readout of the pixels is started. Pixel\_valid goes low when the pixel counter reaches the value loaded in the Nrof\_pixels register. Eol goes high Sys\_clock cycle after the falling edge of Pixel\_valid.
- T3 EOF goes high when the line counter reaches the value loaded in the NROF\_LINES register and the line is read (PIXEL\_VALID goes low).
- T4 The time delay between successive Y\_CLOCK pulses needs to be equal to avoid any horizontal illumination (integration) discrepancies in the image.

Both EOF and EOL can be tied to Y\_START (EOF) and Y\_CLOCK (EOL) if both signals are delayed with at least 2 SYS\_CLOCK periods to let the sensor run automatically. It must however be noted that on power-on, the FIRST Y\_START and Y\_CLOCK must be generated by the external system.



Figure 18. Basic Frame and Line Timing

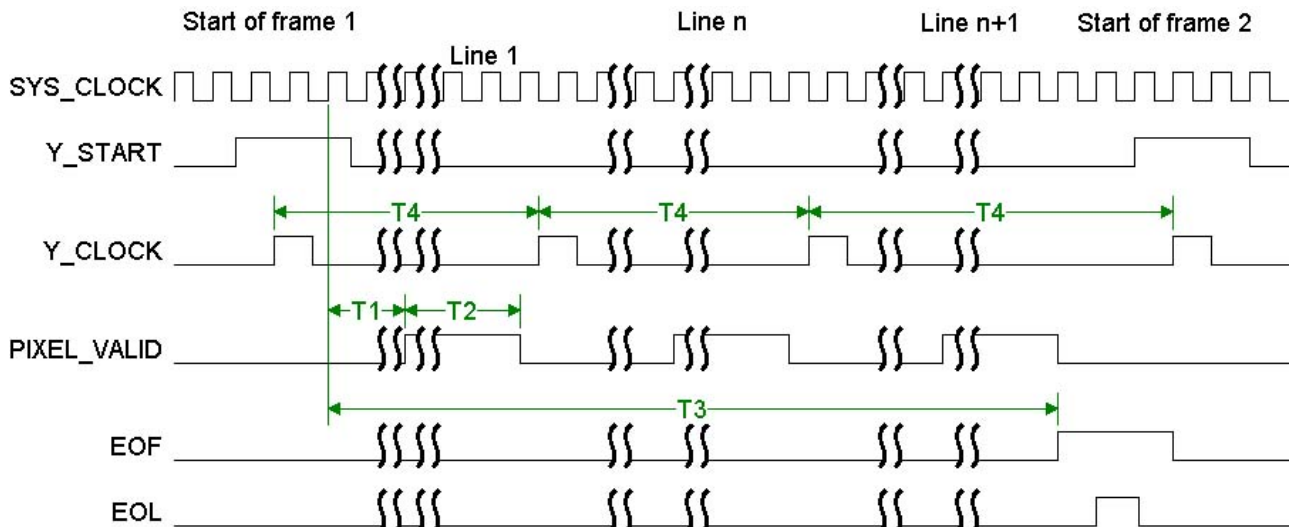

**Pixel Output Timing**

Using Two Analog Outputs

Figure 19. Pixel Output Timing using Two Analog Outputs

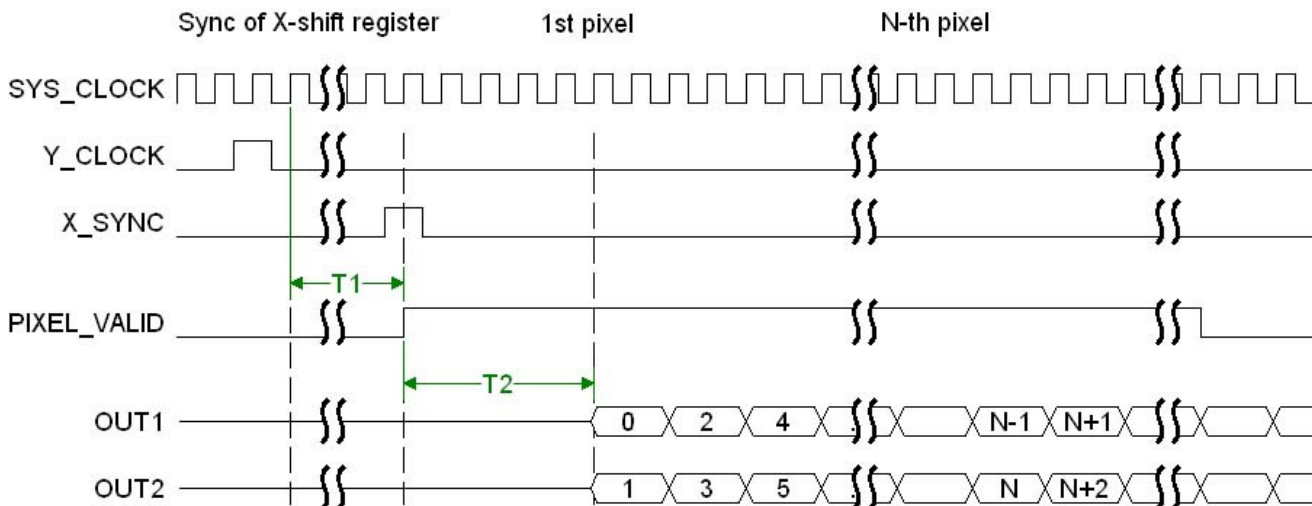

The pixel signal at the OUT1 (OUT2) output becomes valid after four SYS\_CLOCK cycles when the internal X\_SYNC (equal to start of PIXEL\_VALID output) appears (see Figure 19). The PIXEL\_VALID and EOL/EOF pulses can be delayed by the user through the DELAY register.

T1: Row blanking time (see Table 13 on page 20)

T2: 4 SYS\_CLOCK cycles.

*Multiplexing to One Analog Output*

The pixel signal at the OUT1 output becomes valid after five SYS\_CLOCK cycles when the internal X\_SYNC (equal to start of PIXEL\_VALID output) appears (see Figure 20). The PIXEL\_VALID and EOL/EOF pulses can be delayed by the user through the DELAY register.

T1: Row blanking time

T2: 5 SYS\_CLOCK cycles.



Figure 20. Pixel Output Timing Multiplexing to One Analog Output

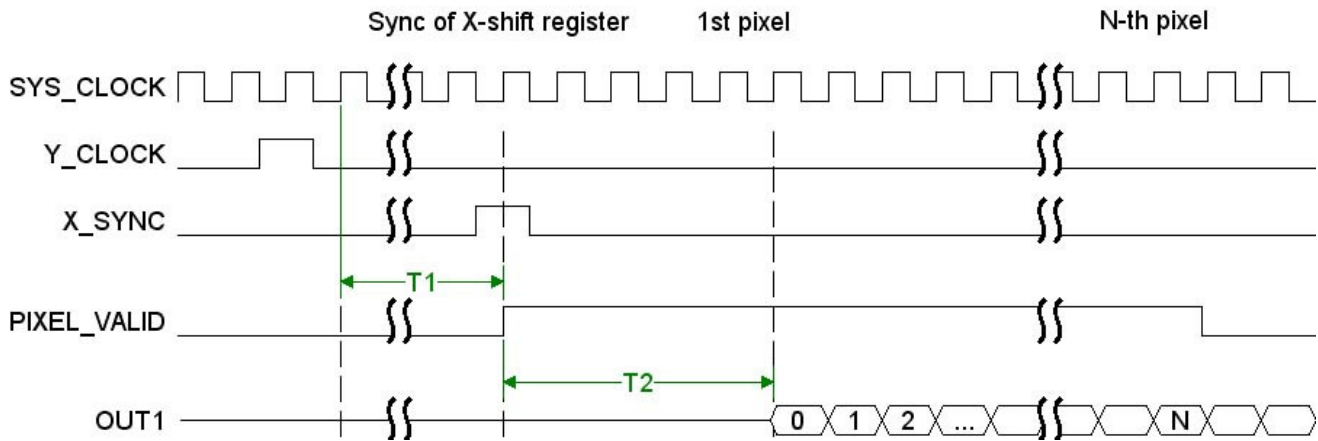

**ADC Timing**

**Two Analog Outputs**

Figure 21 shows the timing of the ADC using two analog outputs. Internally, the ADCs sample on the falling edge of the ADC\_CLOCK (in case of internal clock, the clock is half the SYS\_CLOCK).

T1: Each ADC has a pipeline delay of 2 ADC\_CLOCK cycles. This results in a total pipeline delay of four pixels.

Figure 21. ADC Timing using Two Analog Outputs

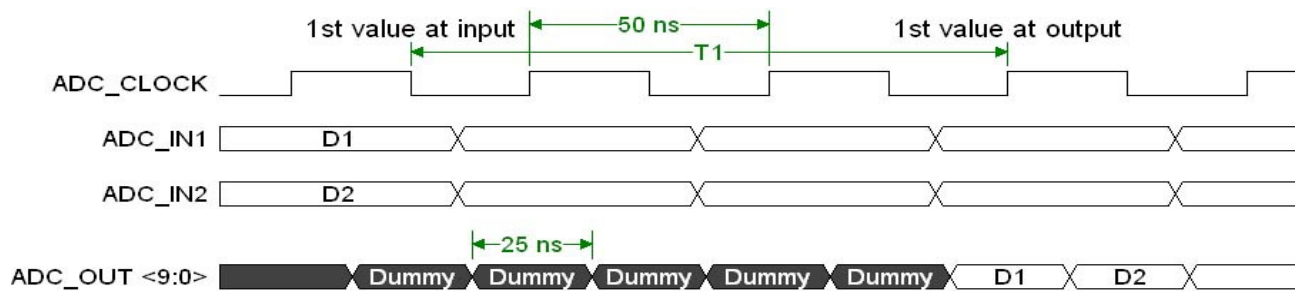

**One Analog Output**

Figure 22 shows the timing of the ADC using one analog output. Internally, the ADC samples on the falling edge of the ADC\_CLOCK.

T1: The ADC has a pipeline delay of 2 ADC\_CLOCK cycles.

Figure 22. ADC Timing using One Analog Output

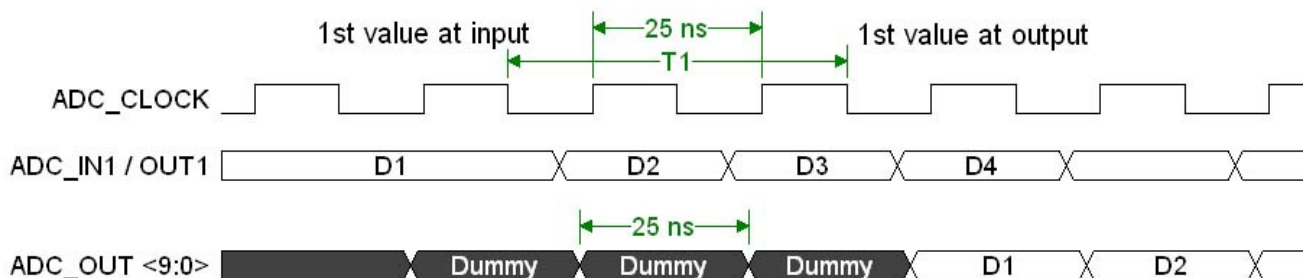

## Package Information

### Pin List Description

The following table lists all the pins and their functions. There are a total of 68 pins. All pins with the same name can be connected together.

**Table 16. Pin List**

Pin	Pin Name	Pin Type	Expected Voltage [V]	Pin Description
1	CMD_COL_CTU	Input	0	Biasing of columns (ctu). Decouple with 100 nF to GNDA.
2	CMD_COL	Input	1.08	Biasing of columns. Connect to $V_{DDA}$ with $R = 10\text{ k}\Omega$ and decouple to GNDA with $C = 100\text{ nF}$ .
3	CMD_COLAMP	Input	0.66	Biasing of column amplifiers. Connect to $V_{DDA}$ with $R = 100\text{ k}\Omega$ and decouple to GNDA with $C = 100\text{ nF}$ .
4	CMD_COLAMP_CTU	Input	0.37	Biasing of column amplifiers. Connect to $V_{DDA}$ with $R = 10\text{ M}\Omega$ and decouple to GNDA with $C = 100\text{ nF}$ .
5	RCAL_DAC_DARK	Input	1.27 at code 128 DAC_DARK reg	Biasing of DAC for dark reference. Can be used to set output range of DAC. Default: Decouple to GNDA with $C = 100\text{ nF}$
6	RCAL_DAC_OUT	Input	0	Biasing of DAC for output dark level. Can be used to set output range of DAC. Default: Connect to GNDA
7	$V_{DDA}$	Power	2.5	$V_{DD}$ of analog part [2.5V]
8	GNDA	Power	0	GND (&substrate) of analog part
9	$V_{DDD}$	Power	2.5	$V_{DD}$ of digital part [2.5V]
10	GNDD	Power	0	GND (&substrate) of digital part
11	CMD_OUT_1	Input	0.78	Biasing of first stage output amplifiers. Connect to $VDDAMP$ with $R = 50\text{ k}\Omega$ and decouple to $GNDAMP$ with $C = 100\text{ nF}$ .
12	CMD_OUT_2	Input	0.97	Biasing of second stage output amplifiers. Connect to $VDDAMP$ with $R = 25\text{ k}\Omega$ and decouple to $GNDAMP$ with $C = 100\text{ nF}$ .
13	CMD_OUT_3	Input	0.67	Biasing of third stage output amplifiers. Connect to $VDDAMP$ with $R = 100\text{ k}\Omega$ and decouple to $GNDAMP$ with $C = 100\text{ nF}$ .
14	SPI_CLK	Input	-	Clock of digital parameter upload. Shifts on rising edge.
15	SPI_DATA	Input	-	Serial address and data input. 16-bit word. Address first. MSB first.
16	$VDDAMP$	Power	2.5	$V_{DD}$ of analog output [2.5V] (Can be connected to $V_{DDA}$ )
17	CMD_FS_ADC	Input	0.73	Biasing of first stage ADC. Connect to $VDDA\_ADC$ with $R = 50\text{ k}\Omega$ and decouple to $GNDA\_ADC$ with $C = 100\text{ nF}$ .
18	CMD_SS_ADC	Input	0.73	Biasing of second stage ADC. Connect to $VDDA\_ADC$ with $R = 50\text{ k}\Omega$ and decouple to $GNDA\_ADC$ .
19	CMD_AMP_ADC	input	0.59	Biasing of input stage ADC. Connect to $VDDA\_ADC$ with $R = 180\text{ k}\Omega$ and decouple to $GNDA\_ADC$ with $C = 100\text{ nF}$ .
20	$GNDAMP$	Ground	0	GND (&substrate) of analog output
21	OUT1	Output	Black level: 1 at code 190 DAC_RAW register	Analog output 1
22	ADC_IN1	Input	See OUT1.	Analog input ADC 1
23	$VDDAMP$	Power	2.5	$V_{DD}$ of analog output [2.5V] (Can be connected to $V_{DDA}$ )
24	OUT2	Output	Black level: 1 at code 190 DAC_RAW register	Analog output 2
25	ADC_IN2	Input	See OUT2.	Analog input ADC 2
26	$V_{DDD}$	Power	2.5	$V_{DD}$ of digital part [2.5V]
27	GNDD	Power	0	GND (&substrate) of digital part

Table 16. Pin List (continued)

Pin	Pin Name	Pin Type	Expected Voltage [V]	Pin Description
28	GNDA	Power	0	GND (&substrate) of analog part
29	V <sub>DDA</sub>	Power	2.5	V <sub>DD</sub> of analog part [2.5V]
30	REG_CLOCK	Input	-	Register clock. Data on internal bus is copied to corresponding registers on rising edge.
31	SYS_CLOCK	Input	-	System clock defining the pixel rate (nominal 40 MHz, 50% ± 5% duty cycle)
32	SYS_RESET	Input	-	Global system reset (active high)
33	Y_CLK	Input	-	Line clock
34	Y_START	Input	-	Start frame readout
35	GNDD_ADC	Power	0	GND (&substrate) of digital part ADC
36	VDDD_ADC	Power	2.5	V <sub>DD</sub> of digital part [2.5V] ADC
37	GNDA_ADC	Power	0	GND (&substrate) of analog part
38	VDDA_ADC	Power	2.5	V <sub>DD</sub> of analog part [2.5V]
39	VHIGH_ADC	Input	1.5	ADC high reference voltage (for example, connect to VDDA_ADC with R = 560 Ω and decouple to GNDA_ADC with C = 100 nF)
40	VLOW_ADC	Input	0.42	ADC low reference voltage (for example, connect to GNDA_ADC with R = 220 Ω and decouple to GNDA_ADC with C = 100 nF)
41	GNDA_ADC	Power	0	GND (&substrate) of analog part
42	VDDA_ADC	Power	2.5	V <sub>DD</sub> of analog part [2.5V]
43	GNDD_ADC	Power	0	GND (&substrate) of digital part ADC
44	VDDD_ADC	Power	2.5	V <sub>DD</sub> of digital part [2.5V] ADC
45	VDD_RESET_DS	Power	2.5 (for no dual slope)	Variable reset voltage (dual slope)
46	ADC_CLK_EXT	Input	-	External ADC clock
47	EOL	Output	-	Diagnostic end of line signal (produced by sequencer), can be used as Y_CLK
48	EOF	Output	-	Diagnostic end of frame signal (produced by sequencer), can be used as Y_START
49	PIX_VALID	Output	-	Diagnostic signal. High during pixel readout
50	TEMP	Output	-	Temperature measurement. Output voltage varies linearly with temperature.
51	ADC_D<9>	Output	-	ADC data output (MSB)
52	VDD_PIX	Power	2.5	V <sub>DD</sub> of pixel core [2.5V]
53	GND_AB	Power	0	Anti-blooming ground. Set to 1V for improved anti-blooming behavior
54	ADC_D<8>	Output	-	ADC data output
55	ADC_D<7>	Output	-	ADC data output
56	ADC_D<6>	Output	-	ADC data output
57	ADC_D<5>	Output	-	ADC data output
58	ADC_D<4>	Output	-	ADC data output
59	ADC_D<3>	Output	-	ADC data output
60	VDD_RESET	Power	2.5	Reset voltage [2.5V]. Highest voltage to the chip. 3.3V for extended dynamic range or 'hard reset'.
61	ADC_D<2>	Output	-	ADC data output
62	ADC_D<1>	Output	-	ADC data output

Table 16. Pin List (continued)

Pin	Pin Name	Pin Type	Expected Voltage [V]	Pin Description
63	ADC_D<0>	Output	-	ADC data output (LSB)
64	BS_RESET	Input	-	Boundary scan (allows debugging of internal nodes): Reset. Tie to GND if not used.
65	BS_CLOCK	Input	-	Boundary scan (allows debugging of internal nodes): Clock. Tie to GND if not used.
66	BS_DIN	Input	-	Boundary scan (allows debugging of internal nodes): In. Tie to GND if not used.
67	BS_BUS	Output	-	Boundary scan (allows debugging of internal nodes): Bus. Leave floating if not used.
68	CMD_DEC	Input	0.74	Biasing of X and Y decoder. Connect to $V_{DD}$ with $R = 50\text{ k}\Omega$ and decouple to $GNDD$ with $C = 100\text{ nF}$ .

Note on Power On Behavior

At power on, the chip is in an undefined state. It is advised that the power on is accompanied by the assertion of the SYS\_CLOCK and a SYS\_RESET pulse that puts all internal registers in their default state (all bits are set to 0). The X-shift registers are in a defined state after the first X\_SYNC, which occurs a few microseconds after the first Y\_START and Y\_CLOCK pulse. Before this X\_SYNC, the chip may draw more current from the analog power supply  $V_{DDA}$ . It is therefore favorable to have separate analog and digital supplies. The current spike (if there are any) may also be avoided by a slower ramp up of the analog power supply or by disconnecting the resistor on pin 3 (CMD\_COLAMP) at startup.

Package Outline Drawing

Figure 23. 68 Pin LCC Packaging Outline

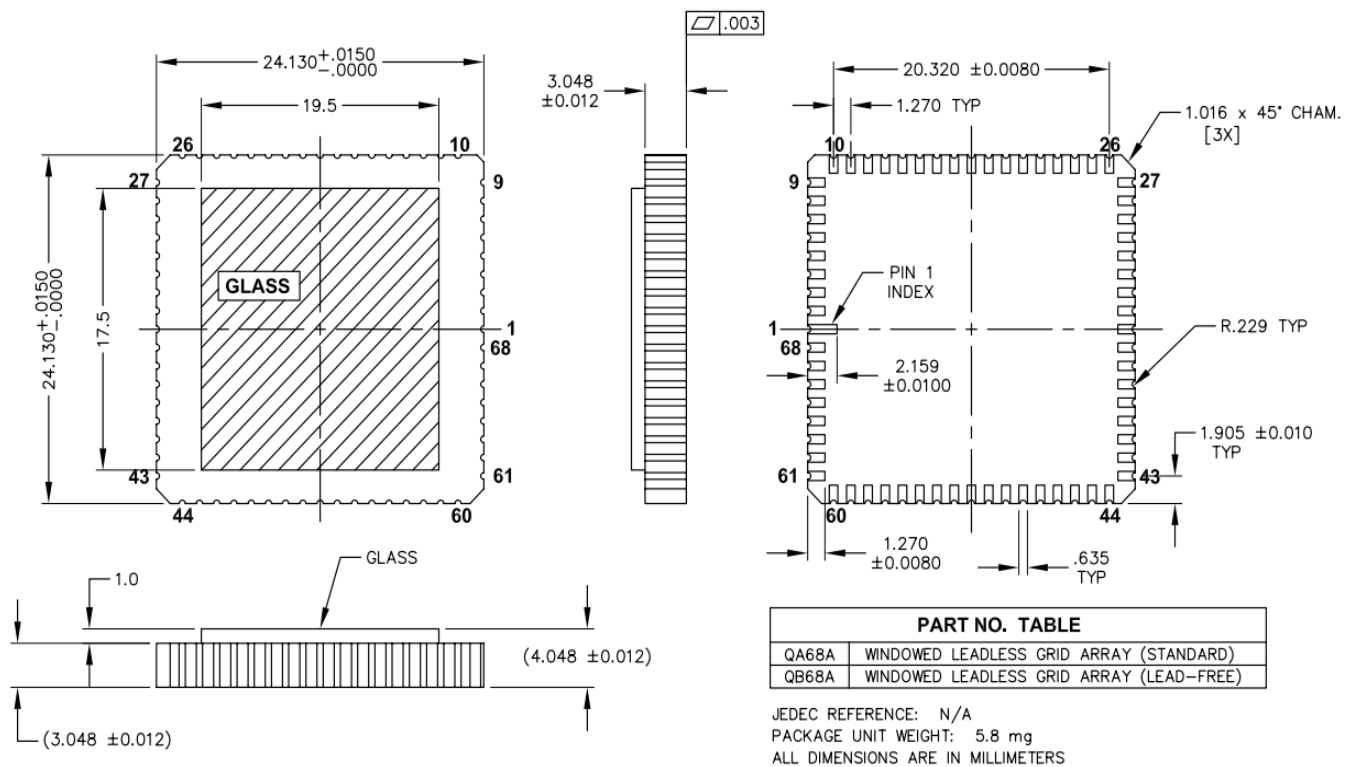

**Glass Lid**

The IBIS4-6600 image sensor uses a glass lid without any coatings. Figure 24 shows the transmission characteristics of the glass lid. As shown in Figure 24, no infrared attenuating filter glass is used. (source: <http://www.pgo-online.com>).

**Figure 24. Transmission Characteristics of the Glass lid**

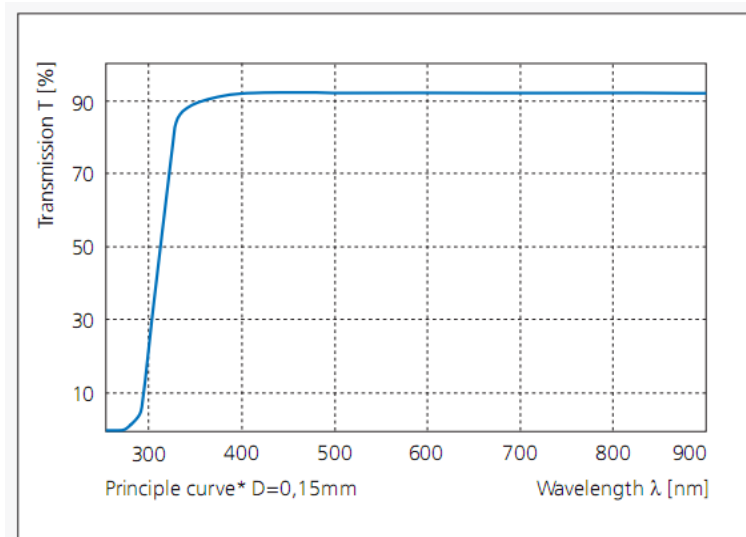

**Handling Precautions**

For proper handling and storage conditions, refer to the ON Semiconductor application note AN52561.

**Limited Warranty**

ON Semiconductor’s Image Sensor Business Unit warrants that the image sensor products to be delivered hereunder, if properly used and serviced, will conform to Seller’s published specifications and will be free from defects in material and workmanship for two (2) years following the date of shipment. If a defect were to manifest itself within 2 (two) year period from the sale date, ON Semiconductor will either replace the product or give credit for the product.

**Return Material Authorization (RMA)**

ON Semiconductor packages all of its image sensor products in a clean room environment under strict handling procedures and ships all image sensor products in ESD-safe, clean-room-approved shipping containers. Products returned to ON Semiconductor for failure analysis should be handled under these same conditions and packed in its original packing materials, or the customer may be liable for the product.

**Acceptance Criteria Specification**

The Product Acceptance Criteria is available on request. This document contains the criteria to which the IBIS4-6600 is tested before being shipped.

**Ordering Code Definition**

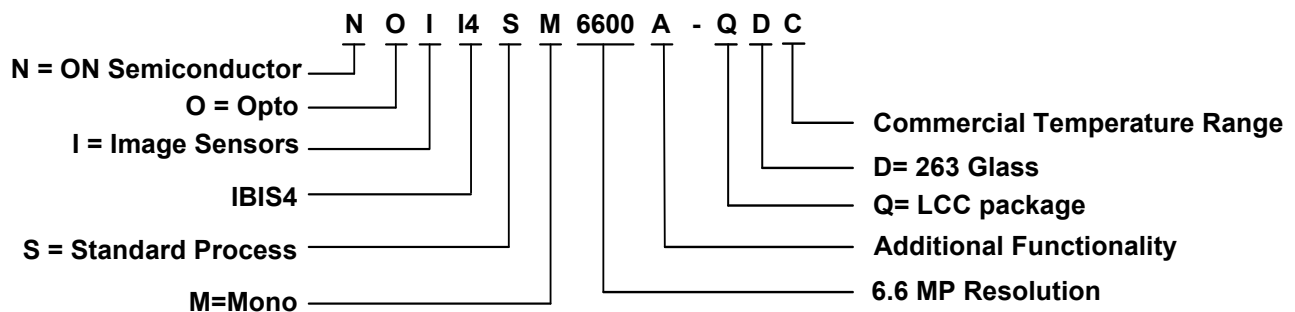

## Acronyms

Acronym	Description
ADC	analog-to-digital converter
AFE	analog front end
BL	black pixel data
CDM	Charged Device Model
CDS	correlated double sampling
CMOS	complementary metal oxide semiconductor
CRC	cyclic redundancy check
DAC	digital-to-analog converter
DDR	double data rate
DFT	design for test
DNL	differential nonlinearity
DS	Double Sampling
DSNU	dark signal non-uniformity
EIA	Electronic Industries Alliance
ESD	electrostatic discharge
FE	frame end
FF	fill factor
FOT	frame overhead time
FPGA	Field Programmable Gate Array
FPN	fixed pattern noise
FPS	frames per second
FS	frame start
HBM	Human Body Model
IMG	regular pixel data
INL	integral nonlinearity

Acronym	Description
IP	intellectual property
LE	line end
LS	line start
LSB	least significant bit
LVDS	low-voltage differential signaling
MBS	mixed boundary scan
MSB	most significant bit
PGA	programmable gain amplifier
PLS	parasitic light sensitivity
PRBS	pseudo-random binary sequence
PRNU	pixel random non-uniformity
QE	quantum efficiency
RGB	red green blue
RMA	Return Material Authorization
RMS	root mean square
ROI	region of interest
ROT	row overhead time
S/H	sample and hold
SNR	signal-to-noise ratio
SPI	serial peripheral interface
TBD	to be determined
TIA	Telecommunications Industry Association
T <sub>J</sub>	Junction Temperature
TR	training pattern
% RH	Percent Relative Humidity

## Glossary

conversion gain	A constant that converts the number of electrons collected by a pixel into the voltage swing of the pixel. Conversion gain = $q/C$ where $q$ is the charge of an electron ( $1.602E-19$ Coulomb) and $C$ is the capacitance of the photodiode or sense node.
CDS	Correlated double sampling. This is a method for sampling a pixel where the pixel voltage after reset is sampled and subtracted from the voltage after exposure to light.
DNL	Differential nonlinearity (for ADCs)
DSNU	Dark signal non-uniformity. This parameter characterizes the degree of non-uniformity in dark leakage currents, which can be a major source of fixed pattern noise.
fill-factor	A parameter that characterizes the optically active percentage of a pixel. In theory, it is the ratio of the actual QE of a pixel divided by the QE of a photodiode of equal area. In practice, it is never measured.
INL	Integral nonlinearity (for ADCs)
IR	Infrared. IR light has wavelengths in the approximate range 750 nm to 1 mm.
Lux	Photometric unit of luminance (at 550 nm, $1\text{lux} = 1 \text{lumen/m}^2 = 1/683 \text{ W/m}^2$ )
pixel noise	Variation of pixel signals within a region of interest (ROI). The ROI typically is a rectangular portion of the pixel array and may be limited to a single color plane.
photometric units	Units for light measurement that take into account human physiology.
PLS	Parasitic light sensitivity. Parasitic discharge of sampled information in pixels that have storage nodes.
PRNU	Photo-response non-uniformity. This parameter characterizes the spread in response of pixels, which is a source of FPN under illumination.
QE	Quantum efficiency. This parameter characterizes the effectiveness of a pixel in capturing photons and converting them into electrons. It is photon wavelength and pixel color dependent.
read noise	Noise associated with all circuitry that measures and converts the voltage on a sense node or photodiode into an output signal.
reset	The process by which a pixel photodiode or sense node is cleared of electrons. "Soft" reset occurs when the reset transistor is operated below the threshold. "Hard" reset occurs when the reset transistor is operated above threshold.
reset noise	Noise due to variation in the reset level of a pixel. In 3T pixel designs, this noise has a component (in units of volts) proportionality constant depending on how the pixel is reset (such as hard and soft). In 4T pixel designs, reset noise can be removed with CDS.
responsivity	The standard measure of photodiode performance (regardless of whether it is in an imager or not). Units are typically $A/W$ and are dependent on the incident light wavelength. Note that responsivity and sensitivity are used interchangeably in image sensor characterization literature so it is best to check the units.
ROI	Region of interest. The area within a pixel array chosen to characterize noise, signal, crosstalk, and so on. The ROI can be the entire array or a small subsection; it can be confined to a single color plane.
sense node	In 4T pixel designs, a capacitor used to convert charge into voltage. In 3T pixel designs it is the photodiode itself.
sensitivity	A measure of pixel performance that characterizes the rise of the photodiode or sense node signal in Volts upon illumination with light. Units are typically $V/(W/m^2)/\text{sec}$ and are dependent on the incident light wavelength. Sensitivity measurements are often taken with 550 nm incident light. At this wavelength, $1 \text{ 683 lux}$ is equal to $1 \text{ W/m}^2$ ; the units of sensitivity are quoted in $V/\text{lux}/\text{sec}$ . Note that responsivity and sensitivity are used interchangeably in image sensor characterization literature so it is best to check the units.
spectral response	The photon wavelength dependence of sensitivity or responsivity.
SNR	Signal-to-noise ratio. This number characterizes the ratio of the fundamental signal to the noise spectrum up to half the Nyquist frequency.
temporal noise	Noise that varies from frame to frame. In a video stream, temporal noise is visible as twinkling pixels.



## Document History Page

Document Title: NOI4SM6600A 6.6 Megapixel CMOS Image Sensor				
Rev.	ECN	Submission Date	Orig. of Change	Description of Change
**	384900	See ECN	FWU	Origination.
*A	402976	See ECN	FWU	Preliminary notice removed. Electro optical spec updated to characterization data.
*B	418669	See ECN	FVK	Table 16. ADC resistor values changed. ADC section added. Figure 33 p41 corrected
*C	502551	See ECN	QGS	Converted to Frame file
*D	642596	See ECN	FPW	Ordering information update
*E	2649816	03/17/2009	PCI/AESA	Final data sheet. Changed title from "IBIS4-A-6600 CMOS Image Sensor" to "IBIS4-6600 CYI4SM6600AB 6.6 MP CMOS Image Sensor". Updated Typical Response Curve of the RGB Filters on Page 7 and added Relative Response Graph on page 8. Updated Package Diagrams and data sheet template.
*F	2766198	09/19/09	NVEA	Updated Ordering Information table
*G	2902961	04/01/10	NVEA	Removed inactive part from <a href="#">IBIS4-6600 Image Sensor</a> .
*H	3153355	01/27/2011	NVEA	Removed inactive parts (color, demo kits and JLCC package) from <a href="#">Ordering Information</a> . Added <a href="#">Contents</a> , <a href="#">Recommended Operating Ratings</a> <sup>[1],[3]</sup> . Edited <a href="#">Absolute Maximum Ratings</a> <sup>[2],[3],[4]</sup> and <a href="#">Recommended DC Operating Conditions</a> on page 6. Edited typical Power Dissipation from 190 mW to 225 mW. Removed section Setting Internal ADC voltages. Added " <a href="#">Black Calibration</a> " on page 11. Edited section <a href="#">Pixel Rate</a> and " <a href="#">Subsampling Modes</a> " on page 12, <a href="#">Glass Lid</a> , <a href="#">Limited Warranty</a> , <a href="#">Return Material Authorization (RMA)</a> and <a href="#">Ordering Code Definition</a> on page 29, <a href="#">Acronyms</a> on page 30, <a href="#">Glossary</a> on page 31.
9	N/A	05/31/2011	SKW	Conversion to ON Semiconductor format and orderable part number changes.

ON Semiconductor and the ON logo are registered trademarks of Semiconductor Components Industries, LLC (SCILLC). SCILLC reserves the right to make changes without further notice to any products herein. SCILLC makes no warranty, representation or guarantee regarding the suitability of its products for any particular purpose, nor does SCILLC assume any liability arising out of the application or use of any product or circuit, and specifically disclaims any and all liability, including without limitation special, consequential or incidental damages. "Typical" parameters which may be provided in SCILLC data sheets and/or specifications can and do vary in different applications and actual performance may vary over time. All operating parameters, including "Typicals" must be validated for each customer application by customer's technical experts. SCILLC does not convey any license under its patent rights nor the rights of others. SCILLC products are not designed, intended, or authorized for use as components in systems intended for surgical implant into the body, or other applications intended to support or sustain life, or for any other application in which the failure of the SCILLC product could create a situation where personal injury or death may occur. Should Buyer purchase or use SCILLC products for any such unintended or unauthorized application, Buyer shall indemnify and hold SCILLC and its officers, employees, subsidiaries, affiliates, and distributors harmless against all claims, costs, damages, and expenses, and reasonable attorney fees arising out of, directly or indirectly, any claim of personal injury or death associated with such unintended or unauthorized use, even if such claim alleges that SCILLC was negligent regarding the design or manufacture of the part. SCILLC is an Equal Opportunity/Affirmative Action Employer. This literature is subject to all applicable copyright laws and is not for resale in any manner.

## PUBLICATION ORDERING INFORMATION

## LITERATURE FULFILLMENT:

Literature Distribution Center for ON Semiconductor  
P.O. Box 5163, Denver, Colorado 80217 USA  
Phone: 303-675-2175 or 800-344-3860 Toll Free USA/Canada  
Fax: 303-675-2176 or 800-344-3867 Toll Free USA/Canada  
Email: [orderlit@onsemi.com](mailto:orderlit@onsemi.com)

**N. American Technical Support:** 800-282-9855 Toll Free  
USA/Canada.  
**Europe, Middle East and Africa Technical Support:**  
Phone: 421 33 790 2910  
**Japan Customer Focus Center**  
Phone: 81-3-5773-3850

**ON Semiconductor Website:** [www.onsemi.com](http://www.onsemi.com)

**Order Literature:** <http://www.onsemi.com/orderlit>

For additional information, please contact your local  
Sales Representative