

AS1720

Solenoid / Valve Driver with Current Limitation

1 General Description

The AS1720A is a low side current source providing an optimized DC Operation for power saving and ultra low electro magnetic radiation.

The AS1720B is a low side switch providing a PWM output, which frequency is defined by an internal RC oscillator. The adjustable PWM allows a fine control of the power delivered to the load.

Table 1. Standard Products

Model	Operation Mode
AS1720A	DC Current Source Operation
AS1720B	PWM Switching Operation

The AS1720A and AS1720B can be set to provide a strong initial closure current and is automatically switching to hold mode for power saving. The initial DC current, the hold current and the duty cycle of the PWM can be adjusted by external resistors. An internal thermal sensor prevents damage of the circuit due to excessive heating up.

Both devices are optimized for driving electro - mechanical devices such as valves, solenoids relays, actuators and positioners.

2 Key Features

- Supply Range: +5V to +50V
- Internal VDDA: 3.3V
- Supply Current: 1 mA
- Internal osc frequency: 30kHz
- Fix delay: 136ms
- Adjustable duty cycle: 20% – 90% (AS1720B only)
- Adjustable energising current: 10mA – 100mA
- Adjustable hold current: 30% - 70% of energising current
- Current Limitation
- Thermal shutdown: 150°C
- 8-pin MLPD (2x2mm) Package
- On request SOIC 8 Package (reduced temperature range -40°C to +85°C)

3 Applications

The AS1720 is ideal for fluid and gas flow systems, industrial control, electrical heaters, motor speed control.

Figure 1. AS1720 - Block Diagram

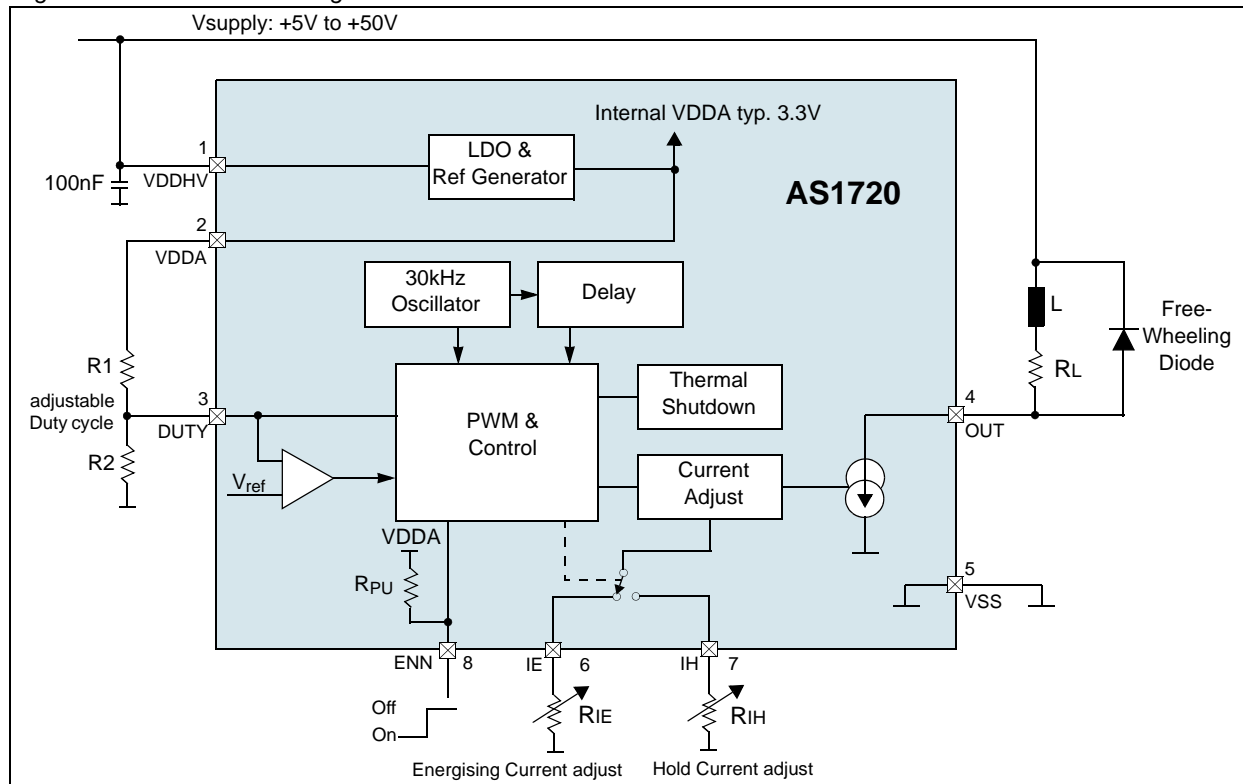

4 Pin Assignments

Figure 2. Pin Out (Top View)

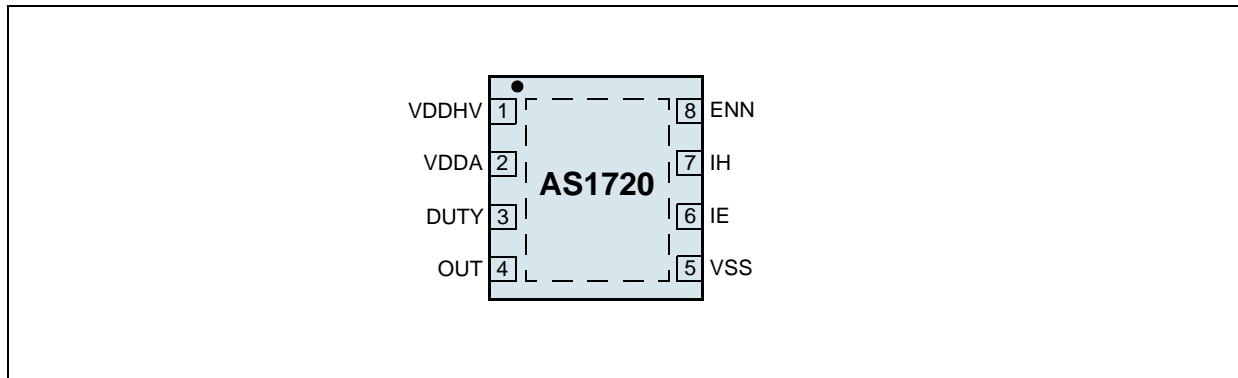

Pin Description

Table 2. Pin Descriptions

Pin Name	Pin Number	Description
VDDHV	1	Positive supply voltage
VDDA	2	Internal supply of 3.3V (typ.)
DUTY	3	Duty-Cycle. By means of this pin the duty cycle can be adjusted between 20% and 90% during hold phase. The duty cycle can be adjusted by a voltage source or an external resistor divider. Setting this pin to VDDA the 50% duty cycle is selected automatically.
OUT	4	Current Source Output
VSS	5	Ground
IE	6	Energize Current. This pin defines the current during energize phase by means of a resistor.
IH	7	Hold Current. This pin defines the current during hold phase by means of a resistor.
ENN	8	<p>Enable Not. This pin can be used to switch on/off the current source (e.g. via a μP), when the AS1720 is always powered on.</p> <p>Low during start-up: When VDDHV is applied, the device starts with the energise phase, followed by the hold phase.</p> <p>When the device is constantly powered on, it can be controlled by this pin.</p> <p>High: The output current source is switched off.</p> <p>Low: The device starts with the energise phase, followed by the hold phase.</p>

5 Absolute Maximum Ratings

Stresses beyond those listed in [Table 3](#) may cause permanent damage to the device. These are stress ratings only, and functional operation of the device at these or any other conditions beyond those indicated in [Section 6 Electrical Characteristics on page 4](#) is not implied. Exposure to absolute maximum rating conditions for extended periods may affect device reliability.

Table 3. Absolute Maximum Ratings

Parameter	Min	Max	Units	Notes
VDDHV, OUT	-0.9	+55	V	
VDDA, DUTY, ENN, IE, IH	-0.3	+5	V	
Latch-Up	-100	100	mA	@85°C, JEDEC 78
ESD	1.5		kV	HBM MIL-Std. 883E 3015.7 methods
Thermal Resistance θ_{JA}	+36		°C/W	
Junction Temperature T_J	+140		°C	Internally limited
Operating Temperature Range	-40	+125	°C	
Storage Temperature Range	-65	+150	°C	
Package Body Temperature	+260		°C	The reflow peak soldering temperature (body temperature) specified is in accordance with IPC/JEDEC J-STD-020D "Moisture/Reflow Sensitivity Classification for Non-Hermetic Solid State Surface Mount Devices". The lead finish for Pb-free leaded packages is matte tin (100% Sn).

6 Electrical Characteristics

$V_{DDHV} = 5V$, $V_{SS} = 0V$, $T_{AMB} = -40^{\circ}C$ to $+125^{\circ}C$ (unless otherwise specified). Typical Values are at $T_{AMB} = +25^{\circ}C$. Limits are 100% production tested at $T_{AMB} = +25^{\circ}C$.

Table 4. Electrical Characteristics

Symbol	Parameter	Conditions	Min	Typ	Max	Units
valid for AS1720A & AS1720B						
V_{DDHV}	Supply Voltage Range		5		50	V
V_{DDA}	Internal Supply	no load	3.1	3.3	3.5	V
I_{DD}	Supply Current			1	2	mA
I_{OUT_E}	Output Energizing Current Range ¹	defined by R_{IE} (see Figure 10 on page 7)	10		100	mA
V_{IH}	Digital Input Threshold	@ pin ENN	2		V_{DDA}	V
V_{IL}			V_{SS}	1.2		
V_{HYST}	Hysteresis	@ pin ENN		200		mV
R_{PU}	Pull-Up Resistor	@ pin ENN		100		k Ω
	Delay Time	See Delay on page 6		136		ms
T_{SHDN}	Thermal Shutdown Temperature			160		$^{\circ}C$
ΔT_{SHDN}	Thermal Shutdown Hysteresis			15		$^{\circ}C$
only valid for AS1720A						
V_{OUT}	Saturation Voltage, Sink ¹	$I_{OUT} = 100mA$		0.6	1	V
k	Transfer Value	$R_{IE} = 12k\Omega$, $V_{DDHV} = 5V$ to $50V$, $OUT = 1V$ to $40V$ (see page 7)	1080	1200	1320	A Ω
I_{OUT_H}	Output Hold Current Range ¹	defined by R_{IH} (see Figure 10 on page 7)	$0.3 \times I_{OUT_E}$		$0.7 \times I_{OUT_E}$	mA
only valid for AS1720B						
	Minimum Duty Cycle		15	20	25	%
	Maximum Duty Cycle		83	90	95	%
	Internal Duty Cycle			50		%
V_{trig}	Triggerlevel to select internal voltage divider	@ pin DUTY		V_{DDA}		V
fPWM	PWM Frequency		25.5	30	34.5	kHz

1. The parameters are tested with proprietary test modes.

Note: All limits are guaranteed. The parameters with min and max values are guaranteed with production tests or SQC (Statistical Quality Control) methods.

7 Typical Operating Characteristics

$V_{SUPPLY} = 5V$, $R_{IE} = 30k\Omega$, $R_{IH} = 120k\Omega$, $T_{AMB} = +25^{\circ}C$ (unless otherwise specified);

Figure 3. Duty Cycle vs. V_{DUTY}

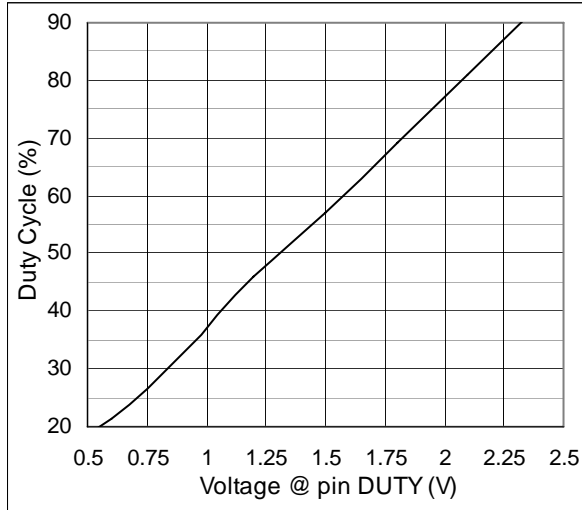

Figure 4. PWM Frequency vs. Temperature

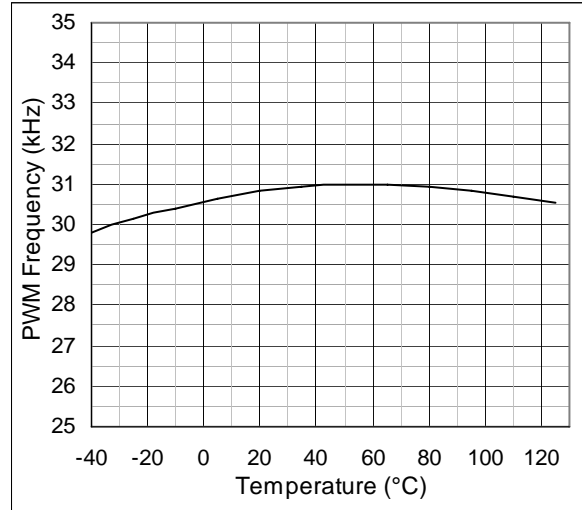

Figure 5. Supply Current vs. Supply Voltage

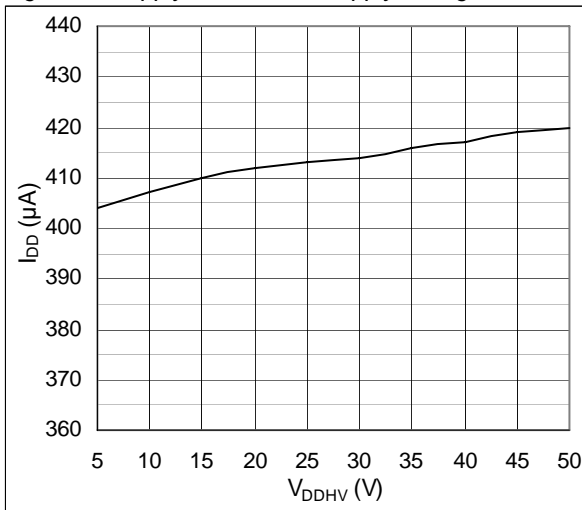

Figure 6. Supply Current vs. Temperature

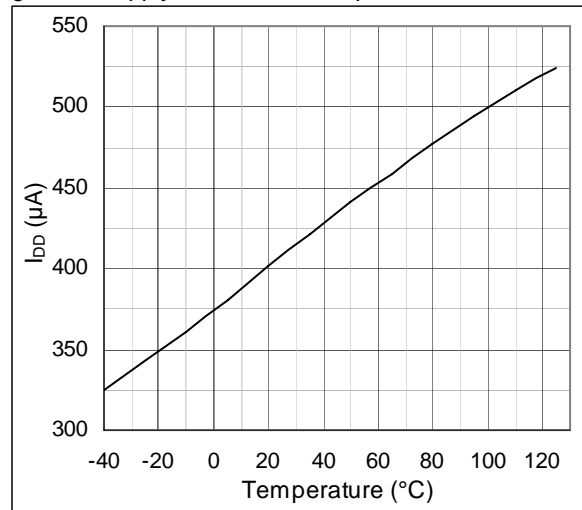

Figure 7. Transfer Function vs. Supply Voltage

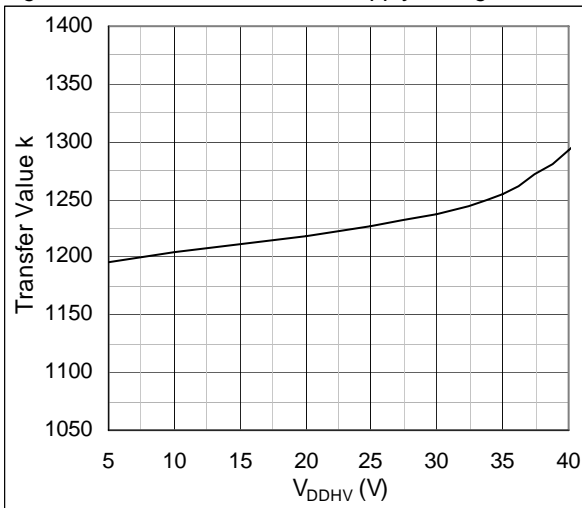
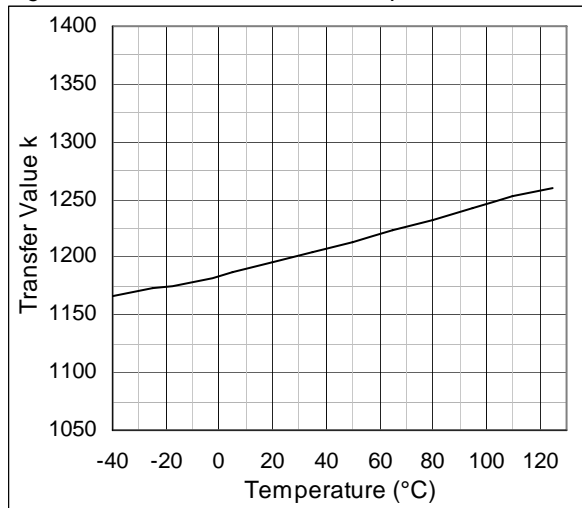

Figure 8. Transfer Function vs. Temperature



8 Detailed Description

Delay

The delay time is generated internally by a digital divider.

LDO and Reference Generator

This block provides the internal supply voltage of typ. 3.3V and all bias currents for the analog cells. Further the external resistor divider for setting the duty cycle will be supplied.

Thermal shutdown

The temperature is constantly monitored. If the temperature exceeds typ. 160°C the output is disabled. In order to exit the over temperature condition, the device has to cool down and the reason of over temperature (e.g. short circuit) must be removed. After exiting the overtemperature condition the system restarts beginning with the energising phase followed by the hold phase.

DC Operation (AS1720A only)

After power up, the delay time (see Delay) starts running. After expiration of the delay the hold phase starts automatically. During the hold phase the DC output current is reduced according to the R_{IH} on pin IH.

PWM Operation (AS1720B only)

After power up, the delay time (see Delay) starts running. After expiration of the delay the hold phase starts automatically. The internal RC oscillator sets the PWM period. The duty cycle is either defined by the external resistor divider (voltage) at pin DUTY or by the fixed internal divider. When using the external divider the duty cycle can be adjusted between 20% and 90% (e.g. from a DAC). Alternatively the pin can be driven by a voltage source. For using the internal divider the pin DUTY has to be connected to VDDA. The comparator recognizes this condition and switches to the internal divider, which causes a fixed 50% duty cycle.

$$DUTYCYCLE(V_{DUTY}) = 0,381 \times V_{DUTY} - 0,014 \quad (EQ 1)$$

Figure 9. Simplified Circuit of Block PWM and Control

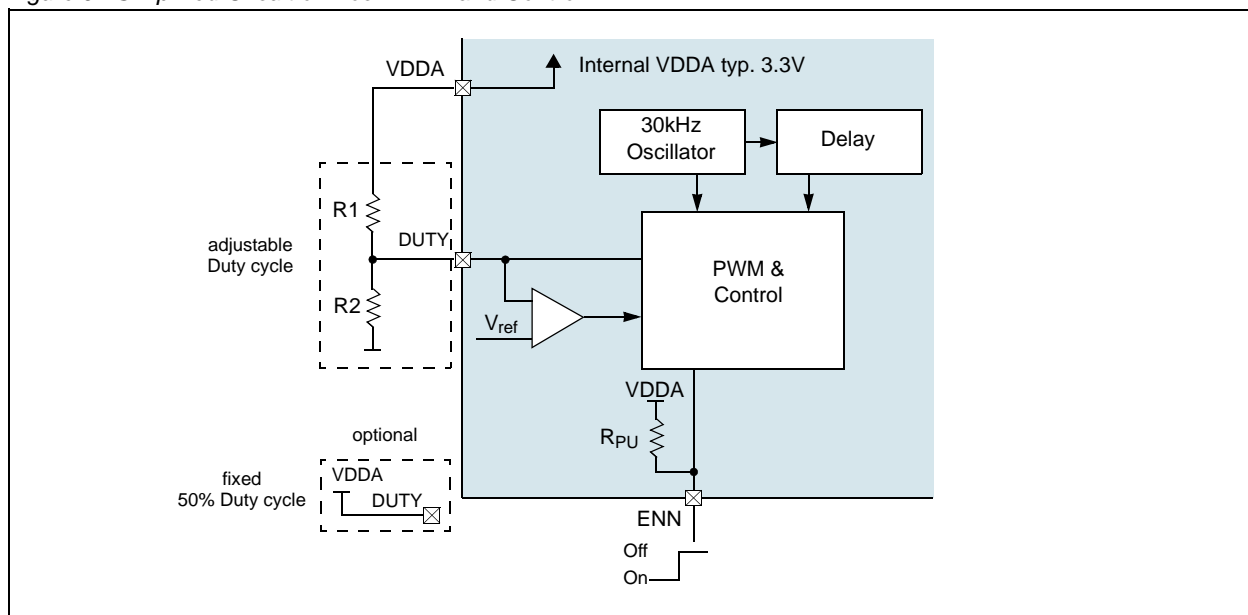

Control by pin ENN

When VDDHV is constantly switched on the AS1720 can be controlled by pin ENN. The functionality is the same as for controlling the device via pin VDDHV. This feature is useful when controlling by a microprocessor is desired.

Because of the internal pull-up resistor to VDDA a microprocessor with open-drain or with push/pull (max 3.3V) output can be used.

Current Adjust (AS1720A) and Current Limitation (AS1720B)

This block provides the current reference for the output current source. The current is generated by regulating the internal Bandgap voltage to the pins IE and IH. The external resistors R_{IE} and R_{IH} define the output current and can be expressed as:

$$R_{IE/IH} = \frac{k}{I_{OUT}} \quad (EQ 2)$$

The temperature coefficient depends on the Bandgap voltage (100ppm/K, box method) and external resistor (in the range of several ppm/K).

The saturation voltage of the output current source for a 100mA current is typical 600mV.

Figure 10. Simplified Circuit of Blocks Current Adjust and Current Source

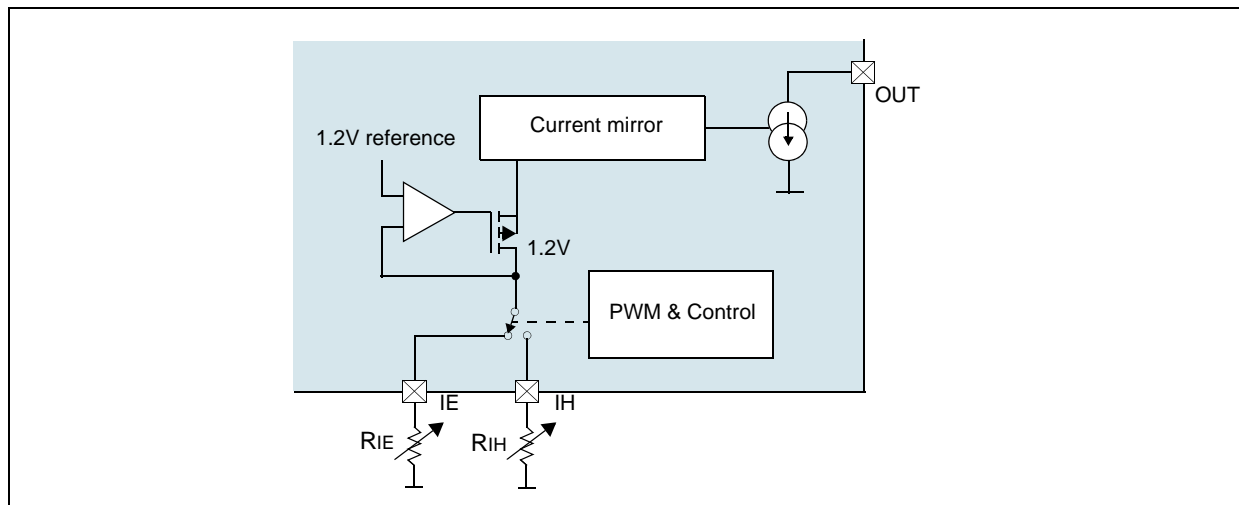

9 Application Information

In order to drive relays, which need more than 100mA current, an external circuitry (see Figure 11) can be used. This application shows how to drive 5W @12V relays.

This circuit is only applicable for AS1720A.

For this example with $R_1 = 100\Omega$ and $R_S = 2.5\Omega$ the current I_S is calculated as follows:

$$I_S = I_1 \times \frac{R_1}{R_S} = 0,01A \times \frac{100}{2,5} = 400mA \quad (EQ 3)$$

Figure 11. AS1720A - Typical Application

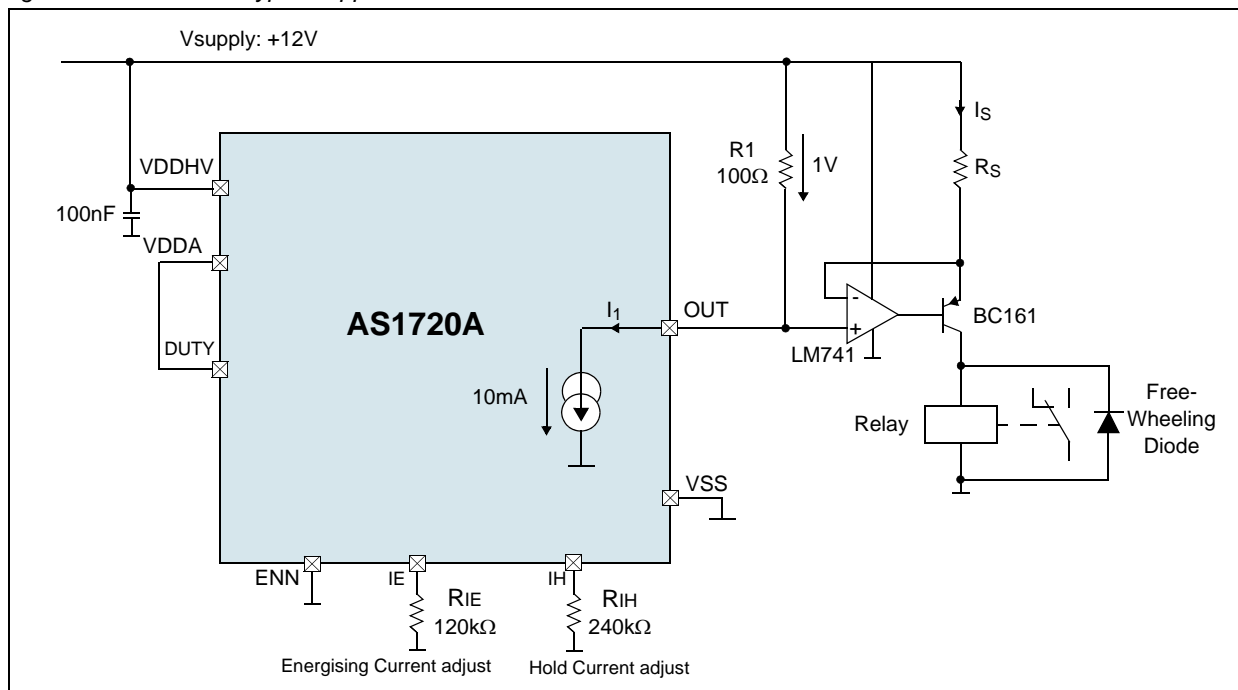

10 Package Drawings and Markings

The device is available in a 8-pin MLPD (2x2mm) package.

Figure 12. 8-pin MLPD (2x2mm) Package Diagram

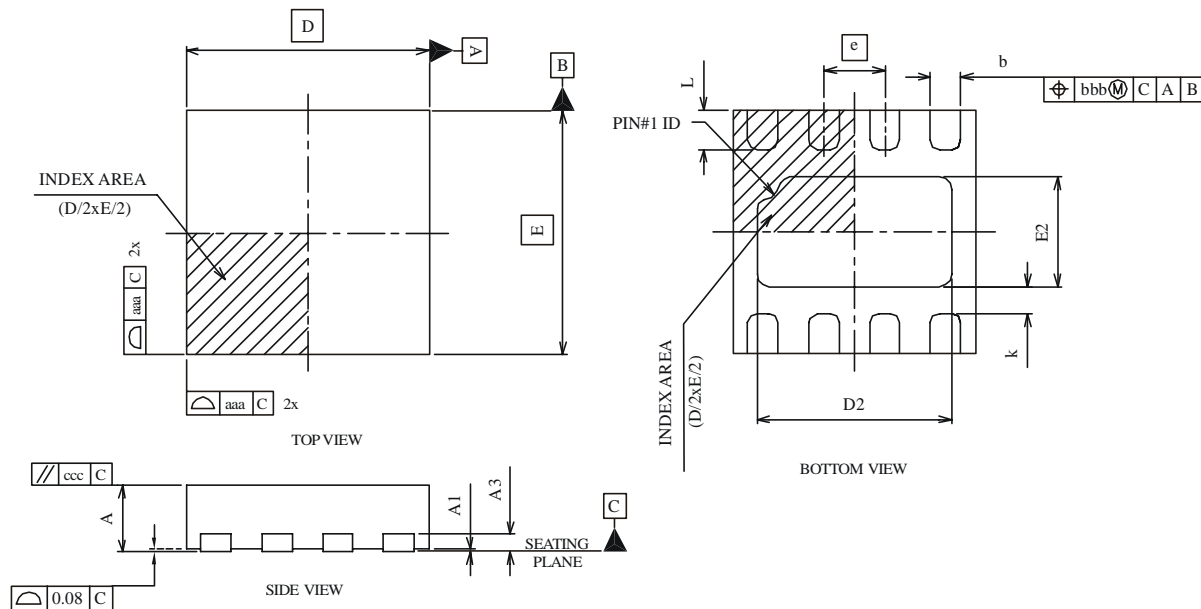

Table 5. 8-pin MLPD (2x2mm) Package Dimensions

Symbol	Min	Typ	Max	Symbol	Min	Typ	Max
A	0.51	0.55	0.60	D BSC		2.00	
A1	0.00	0.02	0.05	E BSC		2.00	
A3		0.15 REF		D2	1.45	1.60	1.70
b	0.20	0.25	0.30	E2	0.75	0.90	1.00
e		0.50		L	0.225	0.325	0.425
aaa		0.15		k	0.20		
bbb		0.10		N		8	
ccc		0.10		ND		4	

Note:

- Figure 12 is shown for illustration only.
- Dimensioning and tolerancing conform to ASME Y14.5M-1994.
- All dimensions are in millimeters, angle is in degrees (°).
- N is the total number of terminals.
- The location of the terminal #1 identifier and terminal numbering convention conforms to JEDEC publication 95 SPP-002.
- ND and NE refer to the number of terminals on each D and E side respectively.
- NJR refer to non jedec registered.
- Dimension b applies to metallized terminal and is measured between 0.15mm and 0.30mm from the terminal tip. If the terminal has the optional radius on the other end of the terminal, the dimension B should not be measured in that radius area.
- Coplanarity applies to the terminals and all other bottom surface metallization.

11 Ordering Information

The device is available as the standard products shown in [Table 6](#).

Table 6. Ordering Information

Ordering Code	Marking	Description	Delivery Form	Package
AS1720A-ATDT	A0	Solenoid / Valve Driver with Current Limitation and with DC Current Source Operation	Tape and Reel	8-pin MLPD (2x2mm)
AS1720B-ATDT	AW	Solenoid / Valve Driver with Current Limitation and with PWM Switching Operation	Tape and Reel	8-pin MLPD (2x2mm)

Note: All products are RoHS compliant and Pb-free.

Buy our products or get free samples online at ICdirect: <http://www.austriamicrosystems.com/ICdirect>

For further information and requests, please contact us <mailto:sales@austriamicrosystems.com> or find your local distributor at <http://www.austriamicrosystems.com/distributor>

Copyrights

Copyright © 1997-2010, austriamicrosystems AG, Tobelbaderstrasse 30, 8141 Unterpremstaetten, Austria-Europe. Trademarks Registered ®. All rights reserved. The material herein may not be reproduced, adapted, merged, translated, stored, or used without the prior written consent of the copyright owner.

All products and companies mentioned are trademarks or registered trademarks of their respective companies.

Disclaimer

Devices sold by austriamicrosystems AG are covered by the warranty and patent indemnification provisions appearing in its Term of Sale. austriamicrosystems AG makes no warranty, express, statutory, implied, or by description regarding the information set forth herein or regarding the freedom of the described devices from patent infringement. austriamicrosystems AG reserves the right to change specifications and prices at any time and without notice. Therefore, prior to designing this product into a system, it is necessary to check with austriamicrosystems AG for current information. This product is intended for use in normal commercial applications. Applications requiring extended temperature range, unusual environmental requirements, or high reliability applications, such as military, medical life-support or life-sustaining equipment are specifically not recommended without additional processing by austriamicrosystems AG for each application. For shipments of less than 100 parts the manufacturing flow might show deviations from the standard production flow, such as test flow or test location.

The information furnished here by austriamicrosystems AG is believed to be correct and accurate. However, austriamicrosystems AG shall not be liable to recipient or any third party for any damages, including but not limited to personal injury, property damage, loss of profits, loss of use, interruption of business or indirect, special, incidental or consequential damages, of any kind, in connection with or arising out of the furnishing, performance or use of the technical data herein. No obligation or liability to recipient or any third party shall arise or flow out of austriamicrosystems AG rendering of technical or other services.



Contact Information

Headquarters

austriamicrosystems AG
Tobelbaderstrasse 30
A-8141 Unterpremstaetten, Austria

Tel: +43 (0) 3136 500 0
Fax: +43 (0) 3136 525 01

For Sales Offices, Distributors and Representatives, please visit:

<http://www.austriamicrosystems.com/contact>