

APPLICATIONS

- Input/Output Filters for voltage regulators, converters, and SMPS
- Battery Decoupling (portable, handheld electronics)
- Power Decoupling (Processor, Transmitter circuits)
- Bulk Capacitor Requirements

FEATURES

- Polymer Cathode Technology
- Extremely Low ESR
- High Frequency Capacitance Retention
- Non-ignition Failure Mode
- Capacitance: 22 to 470 μ F
- Self-healing Mechanism
- -55° to +125°C Capability
- No temperature voltage Derating Up To 125°C
- Robust to Surface Mount Process
- 100% Accelerated Steady State Aging
- Pb Free and RoHS Compliant
- Solid-state Technology
- Molded Case with Wraparound Termination
- Voltage: 2 to 10V
- No Reformation Required
- EIA Standard Case Size
- No Dry-out Related Failure Mechanism

OUTLINE DRAWING

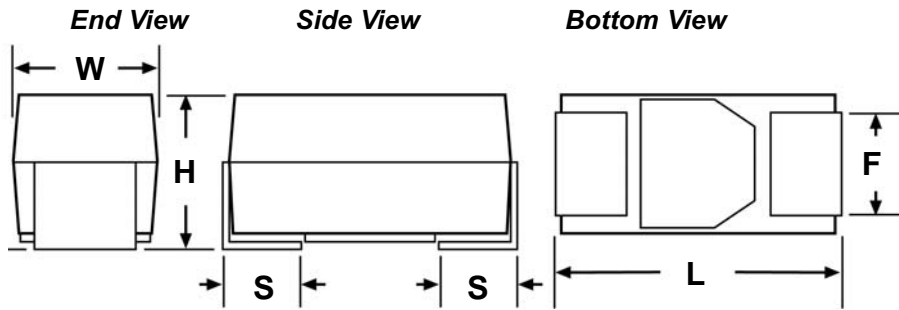

DIMENSIONS - MILLIMETERS

Case Size		L	W	H	F ± 0.1	S ± 0.2
KEMET	EIA					
V	7343-20	7.3 \pm 0.3	4.3 \pm 0.3	1.9 \pm 0.1	2.4	1.3
D	7343-31	7.3 \pm 0.3	4.3 \pm 0.3	2.8 \pm 0.3	2.4	1.3
X	7343-43	7.3 \pm 0.3	4.3 \pm 0.3	4.0 \pm 0.3	2.4	1.3

Note that glue pad shape may differ at KEMET's discretion.

A700 ORDERING INFORMATION

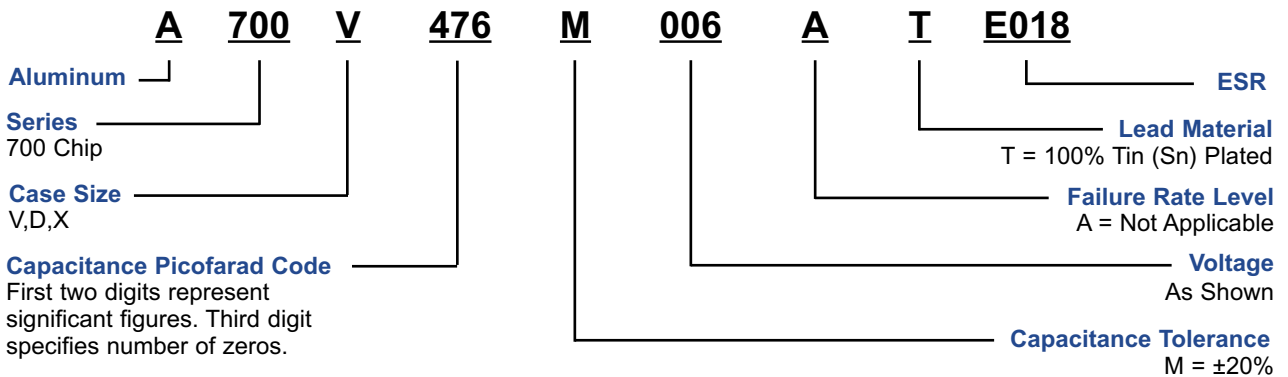

A700 RATINGS & PART NUMBER REFERENCE

KEMET Part Number	Case Size	Cap μF	DCL @V _R	DF @ 120 Hz	ESR 100 kHz (mΩ)	Ripple Current (Arms) @ 100kHz w/ΔT=+20°C @ -55°C to 125°C
2 Volt Rating @ 125°C						
A700V107M002ATE018	V/7343-20	100.0	12.0 μA	6%	18	3.9
A700V107M002ATE025	V/7343-20	100.0	12.0 μA	6%	25	3.3
A700V107M002ATE028	V/7343-20	100.0	12.0 μA	6%	28	3.1
A700V127M002ATE018	V/7343-20	120.0	14.4 μA	6%	18	3.9
A700V127M002ATE025	V/7343-20	120.0	14.4 μA	6%	25	3.3
A700V127M002ATE028	V/7343-20	120.0	14.4 μA	6%	28	3.1
A700V157M002ATE009	V/7343-20	150.0	18.0 μA	6%	9	5.4
A700V157M002ATE018	V/7343-20	150.0	18.0 μA	6%	18	3.9
A700V157M002ATE025	V/7343-20	150.0	18.0 μA	6%	25	3.3
A700V157M002ATE028	V/7343-20	150.0	18.0 μA	6%	28	3.1
A700D187M002ATE015	D/7343-31	180.0	21.6 μA	6%	15	4.1
A700D187M002ATE018	D/7343-31	180.0	21.6 μA	6%	18	3.7
A700V227M002ATE009	V/7343-20	220.0	26.4 μA	6%	9	5.5
A700D227M002ATE015	D/7343-31	220.0	26.4 μA	6%	15	4.1
A700D227M002ATE018	D/7343-31	220.0	26.4 μA	6%	18	3.7
A700X277M002ATE010	X/7343-43	270.0	32.4 μA	6%	10	4.7
A700X277M002ATE012	X/7343-43	270.0	32.4 μA	6%	12	4.3
A700X277M002ATE015	X/7343-43	270.0	32.4 μA	6%	15	3.9
A700V337M002ATE006	V/7343-20	330.0	39.6 μA	6%	6	6.7
A700V337M002ATE009	V/7343-20	330.0	39.6 μA	6%	9	5.5
A700D337M002ATE007	D/7343-31	330.0	39.6 μA	6%	7	6.0
A700X337M002ATE010	X/7343-43	330.0	39.6 μA	6%	10	4.7
A700X337M002ATE015	X/7343-43	330.0	39.6 μA	6%	15	3.9
A700X397M002ATE010	X/7343-43	390.0	46.8 μA	6%	10	4.7
A700X397M002ATE015	X/7343-43	390.0	46.8 μA	6%	15	3.9
A700X477M002ATE010	X/7343-43	470.0	56.4 μA	6%	10	4.7
A700X477M002ATE015	X/7343-43	470.0	56.4 μA	6%	15	3.9
2.5 Volt Rating @ 125°C						
A700V826M2R5ATE018	V/7343-20	82.0	12.3 μA	6%	18	3.9
A700V826M2R5ATE025	V/7343-20	82.0	12.3 μA	6%	25	3.3
A700V826M2R5ATE028	V/7343-20	82.0	12.3 μA	6%	28	3.1
A700D157M2R5ATE015	D/7343-31	150.0	22.5 μA	6%	15	4.1
A700D157M2R5ATE018	D/7343-31	150.0	22.5 μA	6%	18	3.7
A700D187M2R5ATE015	D/7343-31	180.0	27.0 μA	6%	15	4.1
A700D187M2R5ATE018	D/7343-31	180.0	27.0 μA	6%	18	3.7
A700X227M2R5ATE010	X/7343-43	220.0	33.0 μA	6%	10	4.7
A700X227M2R5ATE015	X/7343-43	220.0	33.0 μA	6%	15	3.9
A700X337M2R5ATE010	X/7343-43	330.0	49.5 μA	6%	10	4.7
A700X337M2R5ATE015	X/7343-43	330.0	49.5 μA	6%	15	3.9
A700X477M2R5ATE010	X/7343-43	470.0	70.5 μA	6%	10	4.7
4 Volt Rating @ 125°C						
A700V826M004ATE018	V/7343-20	82.0	19.7 μA	6%	18	3.9
A700V826M004ATE025	V/7343-20	82.0	19.7 μA	6%	25	3.3
A700V826M004ATE028	V/7343-20	82.0	19.7 μA	6%	28	3.1
A700D127M004ATE015	D/7343-31	120.0	28.8 μA	6%	15	4.1
A700D127M004ATE018	D/7343-31	120.0	28.8 μA	6%	18	3.7
A700D157M004ATE015	D/7343-31	150.0	36.0 μA	6%	15	4.1
A700D157M004ATE018	D/7343-31	150.0	36.0 μA	6%	18	3.7
A700D187M004ATE015	D/7343-31	180.0	43.2 μA	6%	15	4.1
A700D187M004ATE018	D/7343-31	180.0	43.2 μA	6%	18	3.7
A700X187M004ATE010	X/7343-43	180.0	43.2 μA	6%	10	4.7
A700X187M004ATE015	X/7343-43	180.0	43.2 μA	6%	15	3.9
A700D227M004ATE009	X/7343-43	220.0	52.8 μA	6%	9	5.3
A700X227M004ATE009	X/7343-43	220.0	52.8 μA	6%	9	5.3
A700X227M004ATE010	X/7343-43	220.0	52.8 μA	6%	10	4.7
A700X227M004ATE015	X/7343-43	220.0	52.8 μA	6%	15	3.9
A700X277M004ATE010	X/7343-43	270.0	64.8 μA	6%	10	4.7
A700X277M004ATE015	X/7343-43	270.0	64.8 μA	6%	15	3.9
A700X337M004ATE010	X/7343-43	330.0	79.2 μA	6%	10	4.7
A700X337M004ATE015	X/7343-43	330.0	79.2 μA	6%	15	3.9

KEMET Part Number	Case Size	Cap µF	DCL @V _R	DF @ 120 Hz	ESR 100 kHz (mΩ)	Ripple Current (Arms) @ 100kHz w/ΔT=+20°C @ -55°C to 125°C
6.3 Volt Rating @ 125°C						
A700V226M006ATE028	V/7343-20	22.0	5.5 µA	6%	28	3.1
A700V226M006ATE045	V/7343-20	22.0	5.5 µA	6%	45	2.4
A700V336M006ATE018	V/7343-20	33.0	8.3 µA	6%	18	3.9
A700V336M006ATE025	V/7343-20	33.0	8.3 µA	6%	25	3.3
A700V336M006ATE028	V/7343-20	33.0	8.3 µA	6%	28	3.1
A700V476M006ATE018	V/7343-20	47.0	11.8 µA	6%	18	3.9
A700V476M006ATE025	V/7343-20	47.0	11.8 µA	6%	25	3.3
A700V476M006ATE028	V/7343-20	47.0	11.8 µA	6%	28	3.1
A700V566M006ATE018	V/7343-20	56.0	14.1 µA	6%	18	3.9
A700V566M006ATE025	V/7343-20	56.0	14.1 µA	6%	25	3.3
A700V566M006ATE028	V/7343-20	56.0	14.1 µA	6%	28	3.1
A700V686M006ATE018	V/7343-20	68.0	17.1 µA	6%	18	3.9
A700V686M006ATE025	V/7343-20	68.0	17.1 µA	6%	25	3.3
A700V686M006ATE028	V/7343-20	68.0	17.1 µA	6%	28	3.1
A700V826M006ATE018	V/7343-20	82.0	20.7 µA	6%	18	3.9
A700V826M006ATE025	V/7343-20	82.0	20.7 µA	6%	25	3.3
A700V826M006ATE028	V/7343-20	82.0	20.7 µA	6%	28	3.1
A700D107M006ATE015	D/7343-31	100.0	25.2 µA	6%	15	4.1
A700D107M006ATE018	D/7343-31	100.0	25.2 µA	6%	18	3.7
A700D127M006ATE012	D/7343-31	120.0	30.2 µA	6%	12	4.6
A700D127M006ATE015	D/7343-31	120.0	30.2 µA	6%	15	4.1
A700D127M006ATE018	D/7343-31	120.0	30.2 µA	6%	18	3.7
A700X157M006ATE010	X/7343-43	150.0	37.8 µA	6%	10	4.7
A700X157M006ATE012	X/7343-43	150.0	37.8µA	6%	12	4.3
A700X157M006ATE015	X/7343-43	150.0	37.8 µA	6%	15	3.9
A700X187M006ATE010	X/7343-43	180.0	45.4 µA	6%	10	4.7
A700X187M006ATE015	X/7343-43	180.0	45.4 µA	6%	15	3.9
A700X227M006ATE015	X/7343-43	220.0	55.4 µA	6%	15	3.9
8 Volt Rating @ 125°C						
A700V226M008ATE028	V/7343-20	22.0	7.0 µA	6%	28	3.1
A700V226M008ATE045	V/7343-20	22.0	7.0 µA	6%	45	2.4
A700V336M008ATE018	V/7343-20	33.0	10.6 µA	6%	18	3.9
A700V336M008ATE025	V/7343-20	33.0	10.6 µA	6%	25	3.3
A700V336M008ATE028	V/7343-20	33.0	10.6 µA	6%	28	3.1
A700D566M008ATE015	D/7343-31	56.0	17.9 µA	6%	15	4.1
A700D566M008ATE018	D/7343-31	56.0	17.9 µA	6%	18	3.7
A700D686M008ATE015	D/7343-31	68.0	21.8 µA	6%	15	4.1
A700D686M008ATE018	D/7343-31	68.0	21.8 µA	6%	18	3.7
A700X107M008ATE010	X/7343-43	100.0	32.0 µA	6%	10	4.7
A700X107M008ATE012	X/7343-43	100.0	32.0 µA	6%	12	4.3
A700X107M008ATE015	X/7343-43	100.0	32.0 µA	6%	15	3.9
10 Volt Rating @ 125°C						
A700V226M010ATE028	V/7343-20	22.0	8.8 µA	6%	28	3.1
A700V336M010ATE018	V/7343-20	33.0	13.2 µA	6%	18	3.9
A700V336M010ATE025	V/7343-20	33.0	13.2 µA	6%	25	3.3
A700V336M010ATE028	V/7343-20	33.0	13.2µA	6%	28	3.1
A700D566M010ATE015	D/7343-31	56.0	22.4 µA	6%	15	4.1
A700D566M010ATE018	D/7343-31	56.0	22.4 µA	6%	18	3.7
A700D686M010ATE015	D/7343-31	68.0	27.2 µA	6%	15	4.1
A700D686M010ATE018	D/7343-31	68.0	27.2 µA	6%	18	3.7
A700X107M010ATE010	X/7343-43	100.0	40.0 µA	6%	10	4.7
A700X107M010ATE015	X/7343-43	100.0	40.0 µA	6%	15	3.9
A700X127M010ATE010	X/7343-43	120.0	48.0 µA	6%	10	4.7
A700X127M010ATE015	X/7343-43	120.0	48.0 µA	6%	15	3.9
A700X157M010ATE010	X/7343-43	150.0	60.0 µA	6%	10	4.7
A700X157M010ATE015	X/7343-43	150.0	60.0 µA	6%	15	3.9
12.5 Volt Rating @ 125°C						
A700V106M12RATE040	V/7343-20	10.0	70.5 µA	6%	40	2.6
A700V106M12RATE060	V/7343-20	10.0	5.0 µA	6%	60	2.1
A700V156M12RATE040	V/7343-20	15.0	7.5 µA	6%	40	2.6
A700V226M12RATE030	V/7343-20	22.0	11.0 µA	6%	30	3.0
A700D476M12RATE025	D/7343-31	47.0	55.4 µA	6%	25	3.2
A700X107M12RATE015	X/7343-43	100.0	55.4 µA	6%	15	3.9
16 Volt Rating @ 125°C						
A700V685M016ATE070	V/7343-20	6.8	4.3 µA	6%	70	1.9
A700V825M016ATE045	V/7343-20	8.2	5.2 µA	6%	45	2.4
A700V106M016ATE045	V/7343-20	10.0	6.4 µA	6%	45	2.4
A700D226M016ATE018	V/7343-31	22.0	14.1 µA	6%	18	3.7
A700D226M016ATE025	V/7343-31	22.0	14.1 µA	6%	25	3.2

Tape & Reel Packaging

KEMET's Molded Tantalum and Aluminum Chip Capacitor families are packaged in 8 mm and 12 mm plastic tape on 7" and 13" reels, in accordance with EIA Standard 481-1: Taping of Surface Mount Components for Automatic Handling. This packaging system is compatible with all tape fed automatic pick and place systems.

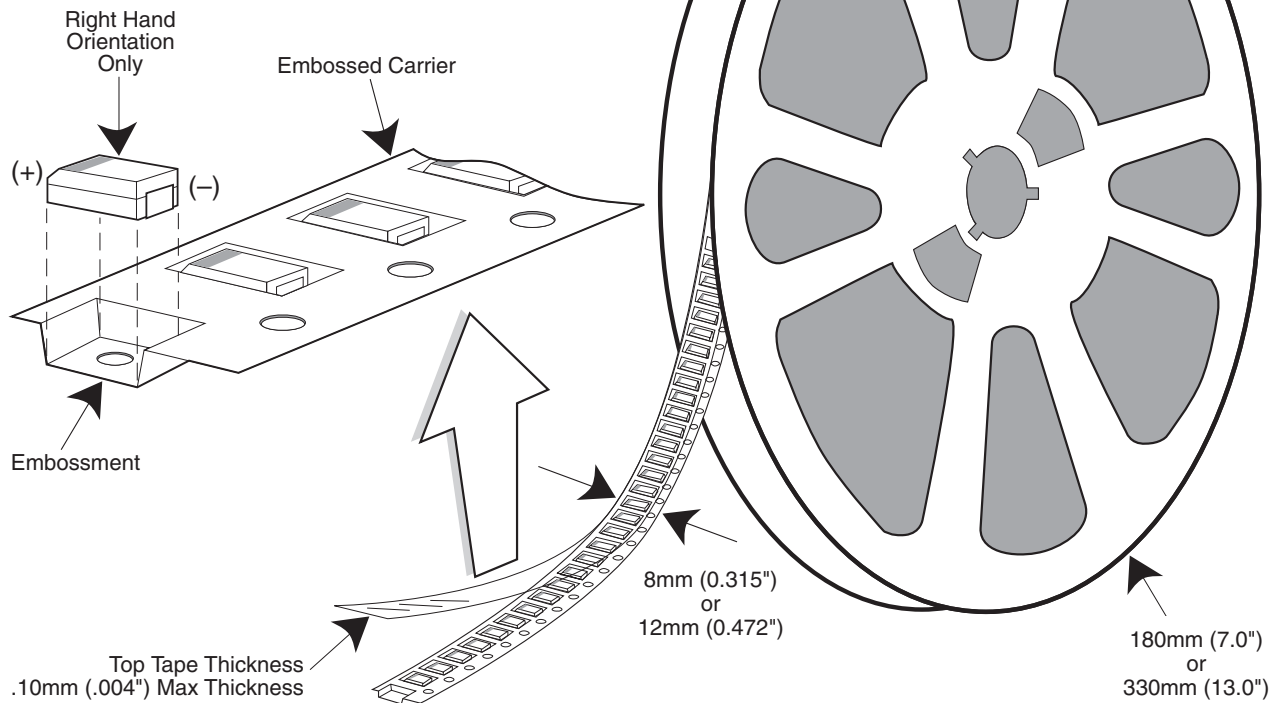

Labeling: Bar code labeling (standard or custom) shall be on the side of the reel opposite the sprocket holes. Refer to EIA-556.

QUANTITIES PACKAGED PER REEL

Case Code		Tape Width-mm	7" Reel*	13" Reel*
KEMET	EIA			
R	2012-12	8	2,500	10,000
S	3216-12	8	2,500	10,000
T	3528-12	8	2,500	10,000
U	6032-15	12	1,000	5,000
W	7343-15	12	1,000	3,000
V	7343-20	12	1,000	3,000
A	3216-18	8	2,000	9,000
B	3528-21	8	2,000	8,000
C	6032-28	12	500	3,000
D	7343-31	12	500	2,500
Y	7343-40	12	500	2,000
X	7343-43	12	500	2,000
E	7260-38	12	500	2,000

* No c-spec required for 7" reel packaging. C-7280 required for 13" reel packaging.

TANTALUM, CERAMIC AND ALUMINUM CHIP CAPACITORS

Packaging Information

Performance Notes

- Cover Tape Break Force:** 1.0 Kg Minimum.
- Cover Tape Peel Strength:** The total peel strength of the cover tape from the carrier tape shall be:

Tape Width	Peel Strength
8 mm	0.1 Newton to 1.0 Newton (10g to 100g)
12 mm	0.1 Newton to 1.3 Newton (10g to 130g)

The direction of the pull shall be opposite the direction of the carrier tape travel. The pull angle of the carrier tape shall be 165° to 180° from the plane of the carrier tape. During peeling, the carrier and/or cover tape shall be pulled at a velocity of 300 ±10 mm/minute.

- Reel Sizes:** Molded tantalum capacitors are available on either 180 mm (7") reels (standard) or 330 mm (13") reels (with C-7280). Note that 13" reels are preferred.
- Labeling:** Bar code labeling (standard or custom) shall be on the side of the reel opposite the sprocket holes. Refer to EIA-556.

Embossed Carrier Tape Configuration: Figure 1



Table 1 — EMBOSSED TAPE DIMENSIONS (Metric will govern)

Constant Dimensions — Millimeters (Inches)									
Tape Size	D ₀	E	P ₀	P ₂	T Max	T ₁ Max			
8 mm and 12 mm	1.5 +0.10 -0.0 (0.059 +0.004, -0.0)	1.75 ±0.10 (0.069 ±0.004)	4.0 ±0.10 (0.157 ±0.004)	2.0 ±0.05 (0.079 ±0.002)	0.600 (0.024)	0.100 (0.004)			
Variable Dimensions — Millimeters (Inches)									
Tape Size	Pitch	B ₁ Max. Note 1	D ₁ Min. Note 2	F	P ₁	R Min. Note 3	T ₂ Max	W	A ₀ B ₀ K ₀ Note 4
8 mm	Single (4 mm)	4.4 (0.173)	1.0 (0.039)	3.5 ±0.05 (0.138 ±0.002)	4.0 ±0.10 (0.157 ±0.004)	25.0 (0.984)	2.5 (0.098)	8.0 ±0.30 (.315 ±0.012)	
12 mm	Double (8 mm)	8.2 (0.323)	1.5 (0.059)	5.5 ±0.05 (0.217 ±0.002)	8.0 ±0.10 (0.315 ±0.004)	30.0 (1.181)	4.6 (0.181)	12.0 ±0.30 (0.472 ±0.012)	

NOTES

- B1 dimension is a reference dimension for tape feeder clearance only.
- The embossment hole location shall be measured from the sprocket hole controlling the location of the embossment. Dimensions of embossment location and hole location shall be applied independent of each other.
- Tape with components shall pass around radius "R" without damage (see sketch A). The minimum trailer length (Fig. 2) may require additional length to provide R min. for 12 mm embossed tape for reels with hub diameters approaching N min. (Table 2)
- The cavity defined by A₀, B₀, and K₀ shall be configured to surround the part with sufficient clearance such that the chip does not protrude beyond the sealing plane of the cover tape, the chip can be removed from the cavity in a vertical direction without mechanical restriction, rotation of the chip is limited to 20 degrees maximum in all 3 planes, and lateral movement of the chip is restricted to 0.5 mm maximum in the pocket (not applicable to vertical clearance.)

Embossed Carrier Tape Configuration (cont.)

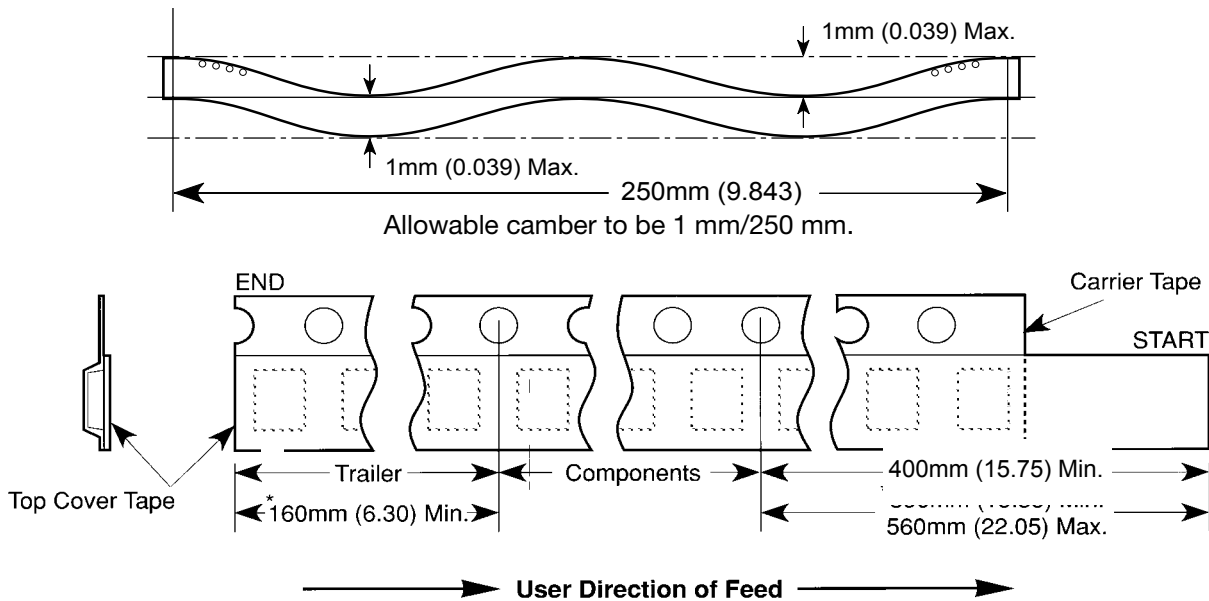
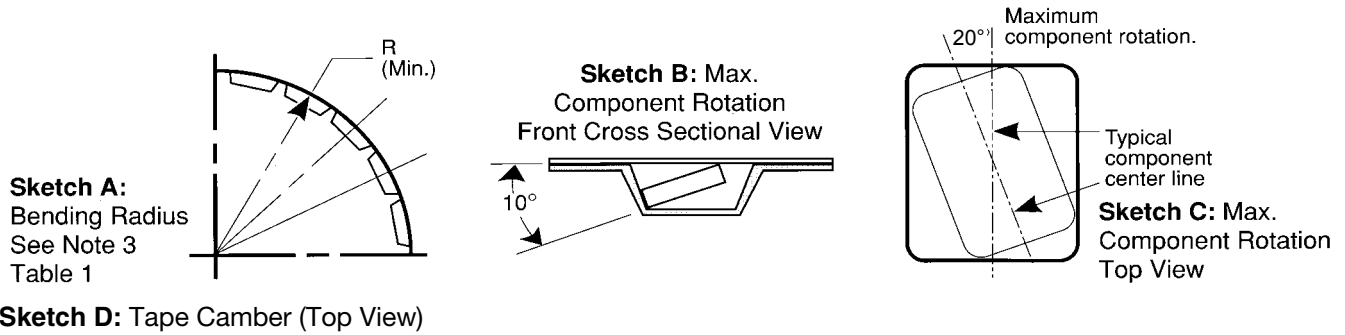

Figure 2:
Tape Leader
& Trailer
Dimensions
(Metric
Dimensions
Will Govern)

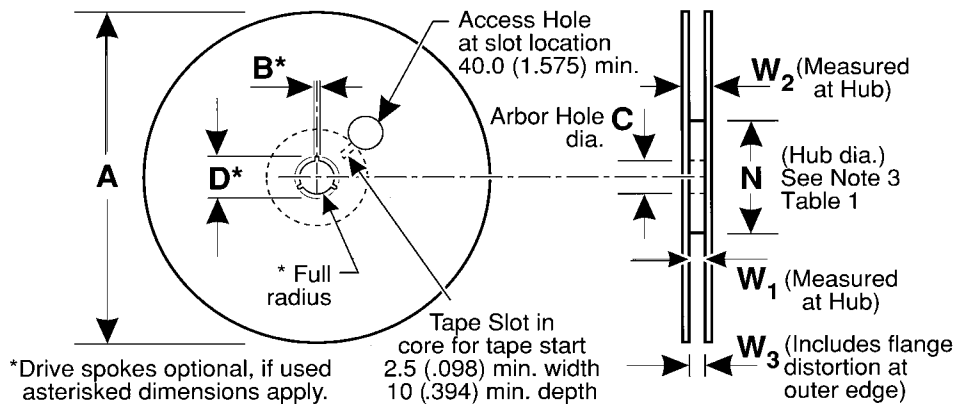

Figure 3: Reel Dimensions (Metric Dimensions will govern)

Table 2 – REEL DIMENSIONS (Metric will govern)

Tape Size	A Max	B* Min	C	D* Min	N Min	W_1	W_2 Max	W_3
8 mm	330.0 (12.992)	1.5 (0.059)	13.0 ± 0.20 (0.512 ± 0.008)	20.2 (0.795)	50.0 (1.969) See Note 3 Table 1	8.4 +1.5, -0.0 (0.331 +0.059, -0.0)	14.4 (0.567)	7.9 Min (0.311) 10.9 Max (0.429)
12 mm	330.0 (12.992)	1.5 (0.059)	13.0 ± 0.20 (0.512 ± 0.008)	20.2 (0.795)	50.0 (1.969) See Note 3 Table 1	12.4 +2.0, -0.0 (0.488 +0.078, -0.0)	18.4 (0.724)	11.9 Min (0.469) 15.4 Max (0.606)