

PLC, I/O & Communications Products

Contents

<i>Description</i>	<i>Page</i>
ELC Programmable Logic Controllers	
Product Family Overview	2
ELC Controllers / Modules	2
ELC Graphic Panels	14
ELC Software	18
EZ Intelligent Relays	
Product Family Overview	19
EZ 500/700/800/EZD Intelligent Relays	20
EZD Controller I/O Modules	27
EZ/EZD Expansion Modules	28
EZ/EZD Communication Modules	30
EZ Software	31
EZ/EZD Power Supplies	32
EZ/EZD Accessories	33
IT. Connect	
Remote I/O Modules (D77A Series)	38
Accessories	50
Starter Network Adapters (SNAP) (D77B Series)	51
DeviceNet SNAP	51
QCPort SNAP	53
Communication Adapters (D77D Series)	55
DeviceNet Adapter	55
Modbus Adapter	57
EtherNet/IP Adapter	59
PROFIBUS Adapter	61
CH Studio Component Manager Software	63

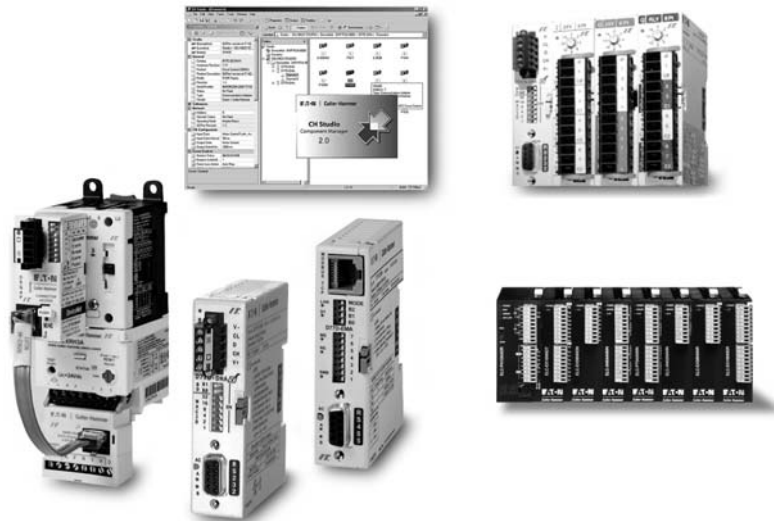

IT. and ELC Products

ELC Product Family Overview



ELC Modules

The Eaton Logic Controller (ELC) is our latest offering into the PLC (Programmable Logic Controller) marketplace. With the latest technology, this reduced sized ELC with its abundant module selection will provide a "Just Right" concept of providing only what you want for the price you need.

- **Size** – Providing large PLC features/functions in a small 1" package. ELC is 1/3 the size of a D50, offering identical and even a larger feature set than the D50. ELC can provide 46 I/O in the space that a D50 could provide 14 I/O.
- **Flexibility** – ELC controllers can handle I/O counts from 10 I/O to 256 I/O using the same controller. ELC eliminates the process of counting I/O and deciding which controller to use, ELC is the only one needed. ELC modules come in many flavors of I/O from modules containing 4 in / 4 out to modules containing 8 in / 8 out. ELC is not a rack based system — it simply mounts to a DIN rail. Add modules by simply snapping them into the mating connectors and closing the attached locks.
- **Large PLC Features** – ELC has the feature set of larger PLCs, from its multiple communications ports, remote I/O ability, data storage, high speed counter, high speed pulse outputs, interrupts, timer resolution to 1 ms, PID, plus much more.

- **Software** – ELCSoft, the software, configures the entire line of ELC controllers. Priced less than \$200, it programs in standard ladder logic and sequential function chart programming. It will aid in knowing what registers are in use and what modules are attached to the ELC. It monitors the runtime application, allows forcing (except basic), and entering values. Software wizards aid programming of remote I/O, standard communications and PIDs.
- **Power of One** – ELC communicates easily to MVX drives, eliminating the need to operate drives by analogue voltage/current or digital I/O. ELC can access all of the parameters in the MVX by serial communications, saving OEM money. ELC communicates to *IT* I/O through the Modbus TCP gateway. This allows ELC to control the *IT* I/O if local control is desired. This will also allow *IT* I/O to be used in communicating MCC applications where the ELC can be either a DeviceNet™, Profibus, or ModbusTCP communicating MCC. ELC communicates to PowerNet Modbus products, allowing ELC connectivity to Switchgear and PowerNet applications.
- **Price** – Following the "Just Right" concept, ELC is priced correctly to please customers.

- High speed pulse capture and high speed pulse output on all controllers
- Interrupts
- Large module selection AC/DC in, relay/transistor out
- Large analogue selection of analogue in, out, combined, thermocouple, RTD Platinum
- Over 200 instructions to choose from: Floating point math, communications, hex, decimal, octal, BCD, ASCII conversion, 1, 4, 8, 16, 32, bit manipulations, logical, block move, block compare, retentive data storage, time base from clock/calendar
- 2 Modbus (ASCII or RTU) serial ports: 1 slave only, 1 master/slave
- Network communications on Modbus TCP, DeviceNet and Profibus
- ELC controller can be wired for remote I/O communications (except the PB model).

ELC Modules

ELC Expansion Modules

ELC expansion modules provide the correct amount of I/O for application solutions. Choose 4, 8, or 16 I/O. Any number of expansion modules can be added to the ELC processor to create 256 I/O (128 Inputs and 128 Outputs maximum).

ELC Specialty Modules

In addition to the expansion I/O, specialty modules like Analogue In, Analogue Out, Platinum Temperature, Thermocouple, DeviceNet, PROFIBUS DP and Switch Module, etc. can be added. Use the ELC-485APTR to easily connect to the RS-485 port of MVX drive, ELC controllers and other devices.

ELC Controllers/Modules

Product Description

ELC Controllers

The ELC family offers four styles of controllers. These controllers offer combinations of the following features:

Catalogue Number Selection

Table 1. ELC Controllers/Modules Catalogue Numbering System

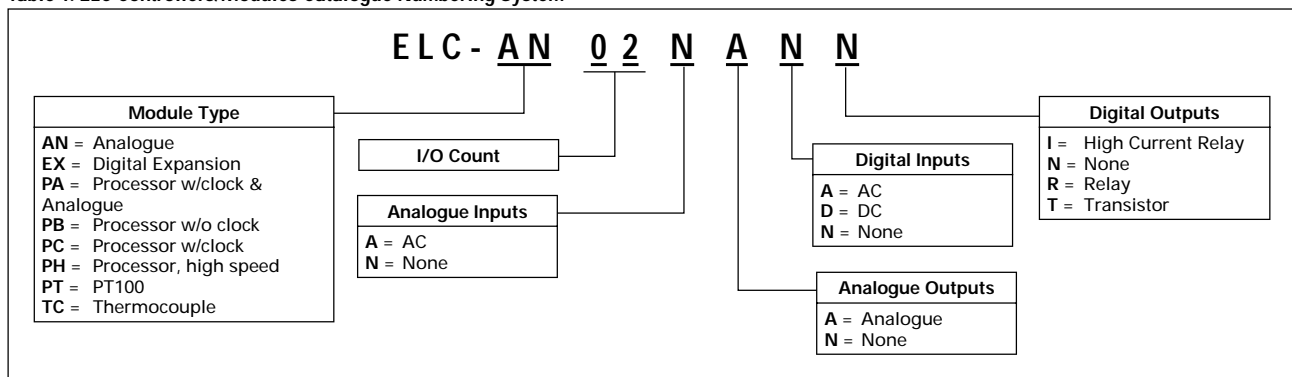

Features

ELC Controllers

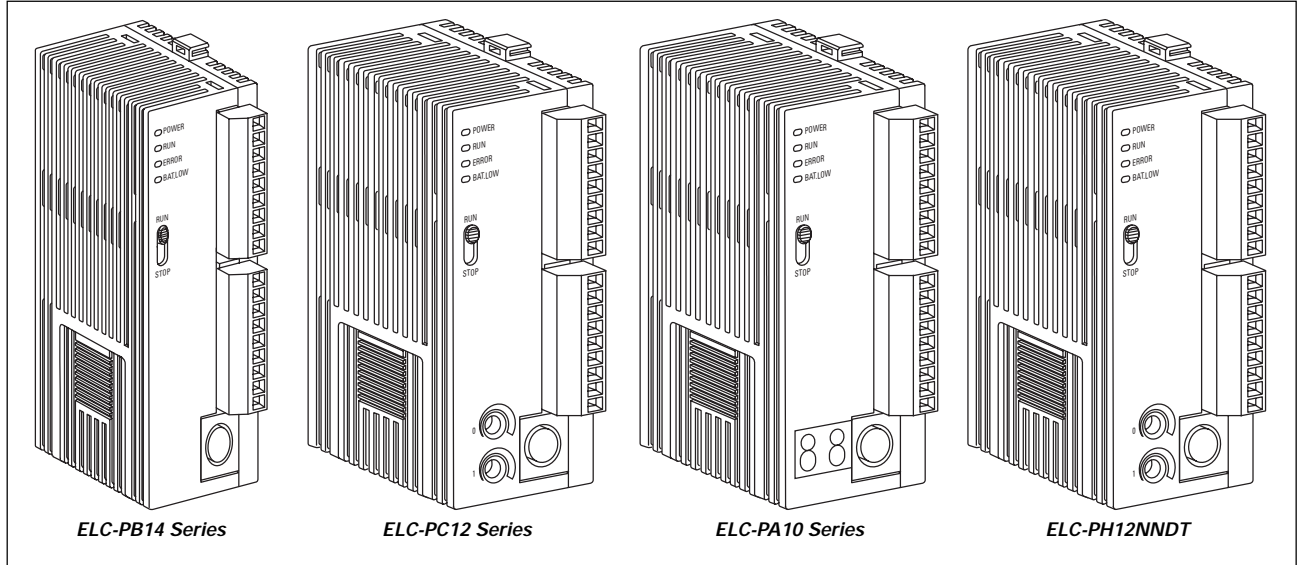
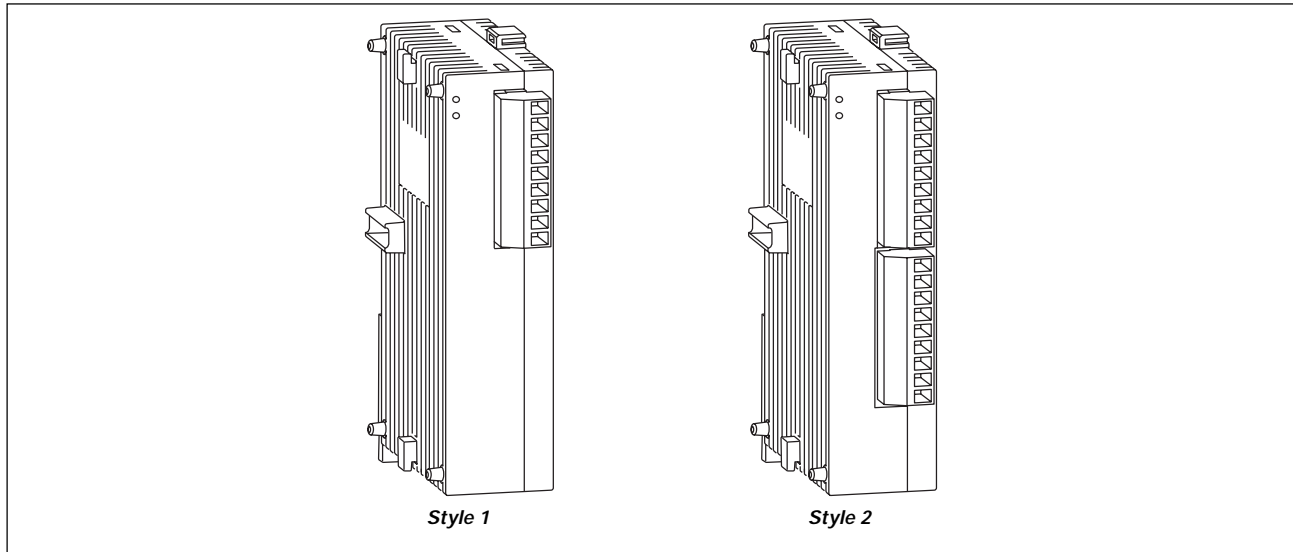

Figure 1. ELC Controllers

Table 2. ELC Controller Features

Items	ELC-PB14 Series	ELC-PC12 Series	ELC-PA10 Series	ELC-PH12NNDT
Maximum I/O	256 (128 In / 128 Out) Any number of modules			
I/O Type	14 (8 In / 6 Out) – Digital	12 (8 In / 4 Out – Digital)	10 (4 In / 2 Out Digital, 2 In / 2 Out Analogue)	12 (8 In / 4 Out – Digital)
Execution Speed	Basic commands - 2µ seconds minimum			
Program Language	Boolean + Ladder Logic + SFC			
Program Capacity	3792 Steps		7920 Steps	
Data Memory Capacity (bits)	1280 Bits		4096 Bits	
Data Memory Capacity (words)	744 Words		5000 Words	
Index Registers	2 Words		8 Words	
File Memory Capacity	—		1600 Words	
Commands	32 Basic / 107 Advanced		32 Basic / 168 Advanced	
Floating Point	Yes		Yes	
SFC Commands	128 Steps		1024 Steps	
Timers	128 (1 – 100 ms)		256 (1 – 100 ms)	
Counters	128 (16 Bit / 32 Bit / Up/Down)		250 (16 Bit / 32 Bit / Up/Down)	
High Speed Counters	4 (14 modes) 10K Max		4 (14 modes) 20 kHz for PA/PC 100 kHz for PH	
Pulse Output	2 channels 10 kHz Max		2 channels, 40 kHz Max for PC/PA, 100 kHz for PH	
Master Control Loop			8 Loops	
Subroutines	64 Subroutines		256 Subroutines	
Interrupts	6		15 (External / Time base / HS CNTR / Comm.)	
Real-time Clock/Calendar	—		Built-in	
Specialty Expansions Modules	8 (Analogue In / Analogue Out / TC / PT) Modules do not count in total I/O			
Serial Ports	2 (1 – RS-232, 1 – RS-485)			
Special Features	—	2 Potentiometers	2 7-Segment Displays	2 Potentiometers

ELC Expansion Modules

Figure 2. ELC Expansion Modules
Table 3. ELC Expansion Module Features

Model	Style	Inputs		Outputs	
		Points	Type	Points	Type
ELC-EX08NNAN — AC IN	1	8	120V AC	0	—
ELC-EX08NNDN — DC IN	1	8	DC Sink or Source	0	—
ELC-EX08NNNR — Relay OUT	1	0	—	8	Relay
ELC-EX08NNNT — Transistor OUT	1	0	—	8	Transistor
ELC-EX06NNNI — High Current Relay OUT	2	0	—	6	Relay (6 Amps)
ELC-EX08NNDR — IN/OUT Combo	2	4	DC Sink or Source	4	Relay
ELC-EX16NNDR — IN/OUT Combo	2	8	DC Sink or Source	8	
ELC-EX08NNDT — IN/OUT Combo	2	4	DC Sink or Source	4	Transistor
ELC-EX16NNDT — IN/OUT Combo	2	8	DC Sink or Source	8	

ELC Specialty Modules

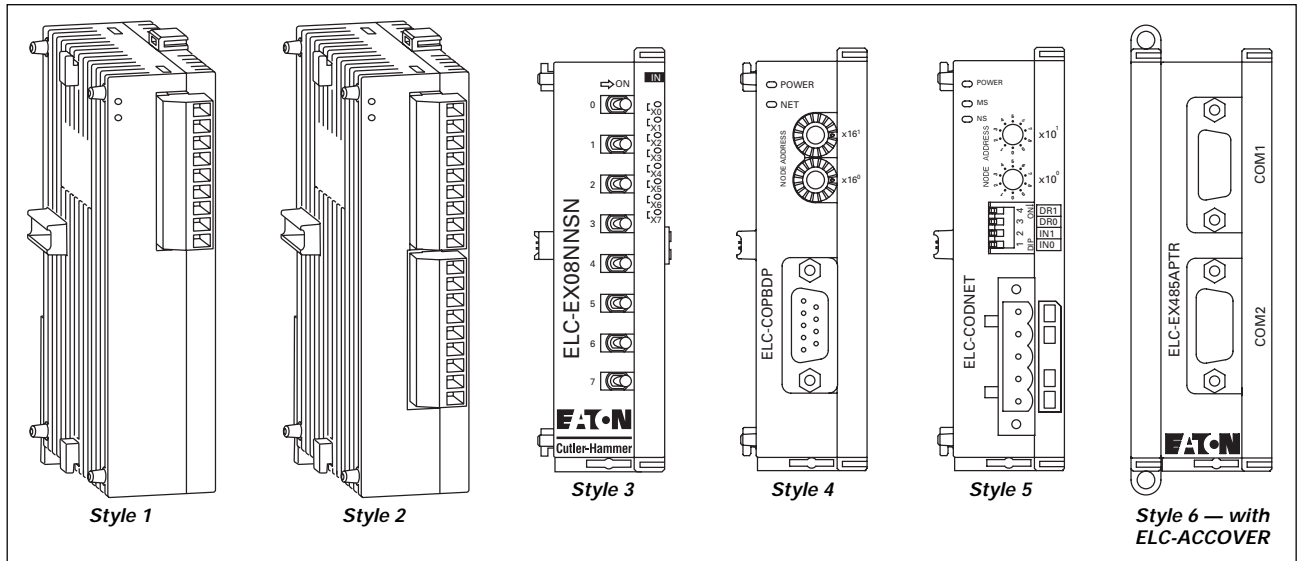

Figure 3. ELC Specialty Expansion Modules

Table 4. ELC Expansion Module Features

Model	Power	Style	Inputs		Outputs	
			Points	Type	Points	Type
ELC-AN02NANN — Analogue OUT	24V DC	1	0	-20 mA~20 mA	2 (12 bits)	0~20 mA, 4~20 mA
ELC-AN04NANN — Analogue OUT		2	0	-10V ~ +10V	4 (12 bits)	0V ~ +10V, 2V ~ +10V
ELC-AN06AANN — Analogue Combo		2	4	±10V, ±20 mA	2 (12 bits)	0~20 mA, 0 ~ +10V
ELC-AN04ANNN — Analogue IN		2	4 (V = 14 bits, I = 11 bits)	±10V, ±20 mA	0	
ELC-PT04ANNN — PT100		2	4 (V = 14 bits, I = 13 bits)	PT100	0	
ELC-TC04ANNN — Thermocouple		2	4	Thermocouple	0	
ELC-EX08NNSN — Switch Input	24V DC	3	8	Switch	0	
ELC-COPBDP — PROFIBUS DP	24V DC	4	32	Digital	32	Digital
ELC-CODNET — DeviceNet	24V DC	5	32	Digital	32	Digital
ELC-485APTR — RS-485 Easy Connect	N/A	6	0	—	0	—

Product Selection

Table 5. ELC Controllers (PB, PC, PA)

Description	Inputs			Outputs			Catalogue Number
	AC	DC	Analogue	Relay	Transistor	Analogue	
14 I/O PB Series 14 I/O PB Series		8 8		6	6		ELC-PB14NNDR ELC-PB14NNDT
12 I/O PC Series 12 I/O PC Series 12 I/O PC Series	8	8 8 8		4 4	4		ELC-PC12NNAR ELC-PC12NNDR ELC-PC12NNDT
10 I/O PA Series 10 I/O PA Series		4 4	2 2	2	2	2	ELC-PA10AADR ELC-PA10AADT
12 I/O PH Series		8			4		ELC-PH12NNDT

Table 6. Digital I/O Expansion Modules

Description	Inputs		Outputs		Catalogue Number
	AC	DC	Relay	Transistor	
6 I/O Expansion (6 Amp Outputs)			6		ELC-EX06NNNI
8 I/O Expansion — AC IN 8 I/O Expansion — AC IN 8 I/O Expansion — Relay OUT 8 I/O Expansion — Transistor OUT 8 I/O Expansion — IN/OUT Combo 8 I/O Expansion — IN/OUT Combo		8	8	8	ELC-EX08NNAN ELC-EX08NNDN ELC-EX08NNNR ELC-EX08NNNT ELC-EX08NNDR ELC-EX08NNDT
16 I/O Expansion — IN/OUT Combo 16 I/O Expansion — IN/OUT Combo		8 8	8	8	ELC-EX16NNDR ELC-EX16NNDT
8 I/O Expansion — Switch Input		8			ELC-EX08NNSN

Table 7. Analogue I/O Modules

Description	Analogue In	Analogue Out	Catalogue Number
4 I/O Analogue In	4		ELC-AN04ANNN
2 I/O Analogue Out		2	ELC-AN02NANN
4 I/O Analogue Out		4	ELC-AN04NANN
6 I/O Analogue In/Out	4	2	ELC-AN06AANN
4 I/O Thermocouple J, K, R, S, T	4		ELC-TC04ANNN
4 I/O Platinum RTD, PT100	4		ELC-PT04ANNN

Table 8. Accessory Modules

Description	Catalogue Number
Profibus DP Module	ELC-COPBDP
DeviceNet Module	ELC-CODNET
RS-485 Easy Connect Adapter, DB9, RJ-12, 2-Pin Connections to RS-485	ELC-485APTR

Standards and Certifications

Table 9. Approvals/Certifications

Description	Specification
Electrical/EMC	
ESD Immunity	8 kV air discharge
EFT Immunity	Power Line: 2 kV; Digital I/O: 1 kV; Analogue & Communication I/O: 250V
Damped-Oscillatory Wave	Power Line: 1 kV; Digital I/O: 1 kV
RS Immunity	26 MHz – 1 GHz, 10 V/m
Other Approvals	
Agency Certifications	UL 508, cUL, CE

Technical Data and Specifications

Table 10. Environmental Ratings

Description	Specification
Transportation & Storage	
Temperature	-13° – 158°F (-25° – 70°C)
Humidity	5 – 95%
Operating	
Temperature	32° – 131°F (0° – 55°C)
Humidity	50 – 95%
Power Supply Voltage	ELC: 24V DC (-15% – 20%) (With DC input reverse polarity protection), Expansion Unit: supplied by the ELC
Power Consumption	3 – 6W
Insulation Resistance	> 5 MΩ at 500V DC (Between all inputs/outputs and earth)
Grounding	The diameter of grounding wire cannot be smaller than the wire diameter of terminals L and N (All ELC units should be grounded directly to the ground pole).
Vibration / Shock Resistance	Standard: IEC1131-2, IEC 68-2-6 (TEST Fc) / IEC1131-2 & IEC 68-2-27 (TEST Ea)
Weight (approx.)	0.348 Lbs (0.158 kg)

Table 11. DC Input Point Electrical Specifications

Description	Specification
Input Type	DC (SINK or SOURCE)
Input Current	24V DC 5 mA
Active Level	OFF → ON, above 16V DC ON → OFF, below 14.4V DC
Response Time	About 10 mS (An adjustment range of 0 – 10,000 mS could be selected through D1020 and D1021)

Table 12. Output Point Electrical Specifications

Output Type	Relay – R	Transistor – T	
Current Specification	1.5A/1 point (5A/COM)	0.3A/1 point @ 40°C; When the output of Y0 and Y1 is high-speed pulse, Y0 and Y1 = 30 mA	
Voltage Specification	Below 250V AC, 30V DC	30V DC	
Maximum Loading	75 VA (Inductive) 90W (Resistive)	9W/1 point	When the output of Y0 and Y1 is high-speed pulse, Y0 and Y1 = 0.9W (Y0 = 32 kHz, Y1 = 10kHz), Y0 can be 50 kHz using D registers.
Response Time	Adjustable 0 – 15 ms, default is 10 ms	OFF → ON 20 μs ON → OFF 30 μs	Y0 and Y1 are specified points for high-speed pulse

ELC Accessories

ELC-GPXFERMOD

Transfer programs to or from ELC-GPxx units. These devices can be write protected to maintain program integrity.

ELC-HHP

ELC-HHP is an easy-to-use, hand-held programming tool for ELC controllers when a PC is not available. With ELC-HHP, applications can be programmed directly with the attached keypad. Or uploaded from an ELC, saved, and transferred to a different ELC. Or

downloaded from a PC and transferred to other ELCs. No need for outlets when using the ELC-HHP since it draws its power from either the ELC or the PC through the attached cable. Monitor applications when a PC is not available.

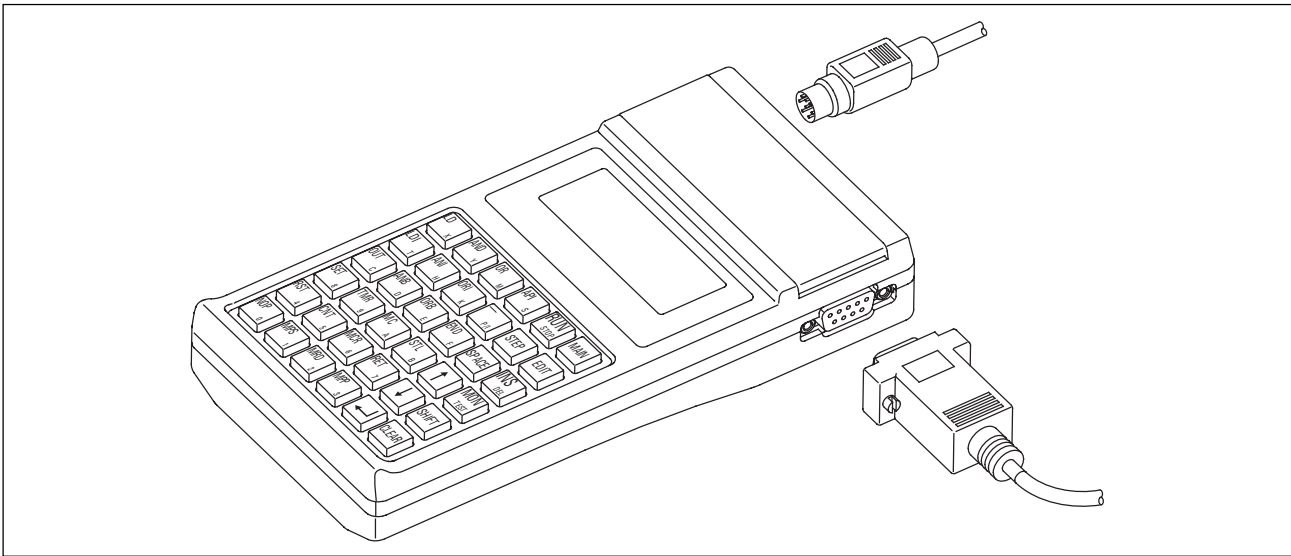

Figure 4. ELC-HHP with Cables for ELC and PC Connections

ELC Power Supplies

All ELC modules operate from 24V DC. These power supplies provide a convenient way to provide robust DC voltage.

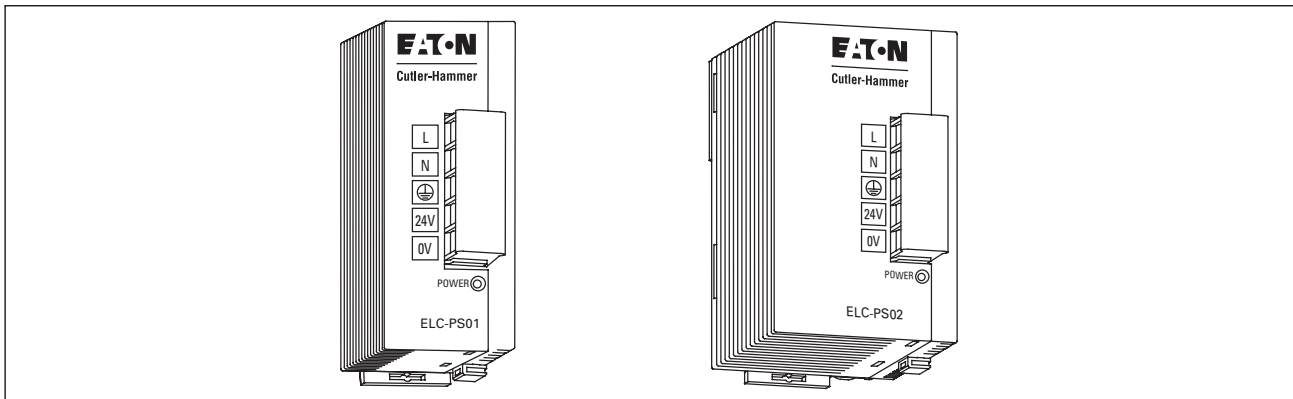

Figure 5. ELC Power Supplies

Table 13. ELC Power Supply Specifications

Item	ELC-PS01	ELC-PS02
Dimensions WxHxD in Inches (mm)	1.44 x 3.54 x 2.36 (36.5 x 90 x 60)	2.17 x 3.54 x 2.36 (55 x 90 x 60)
Input Power	100 – 240V AC 50/60 Hz	
Output Volts	24V DC	
Output Current (A)	1A	2A

ELC-CBPCELC3

Use this cable to download, upload, monitor ELC controllers. Or use this same cable to connect any ELC-GPxx to an ELC controller. This cable is 3 meters long.

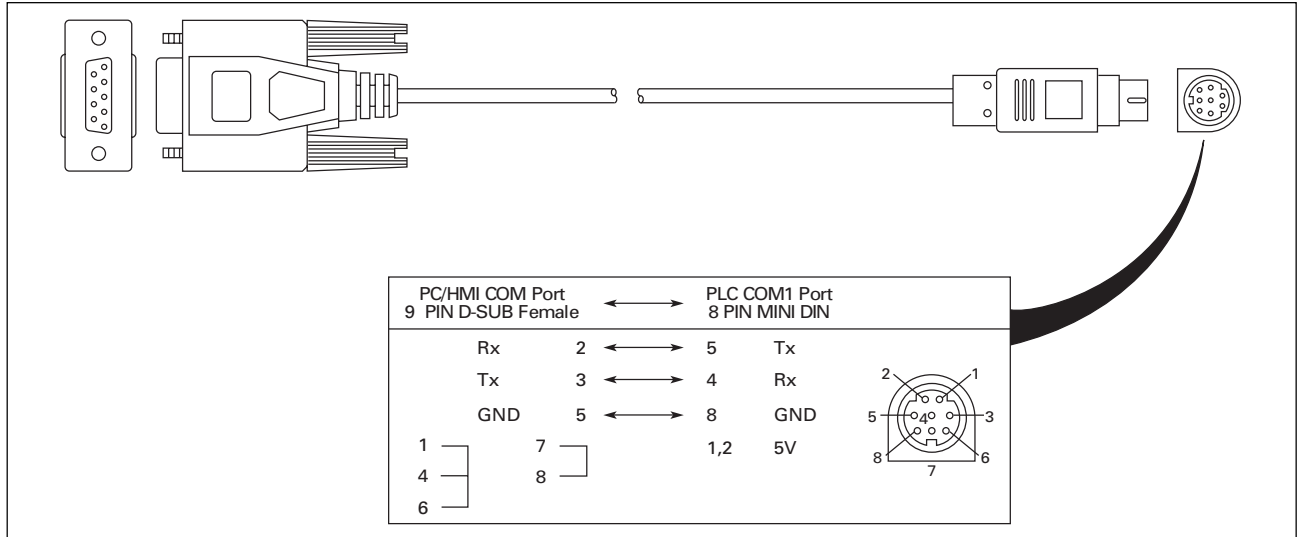

Figure 6. ELC-CBPCELC3 Cable

ELC-CBP3GP3

Use this cable to download or upload applications between a PC and the ELC-GPxx graphic panels. This cable can also be used to transfer a program from an ELC-GPxx to another ELC-GPxx. This cable is 3 meters long.

- The Pin definition of 9 PIN D-SUB RS-232:

ELC-GP04 COM Port RS-232 9 PIN D-SUB Male	
3	Tx
2	Rx
5	GND

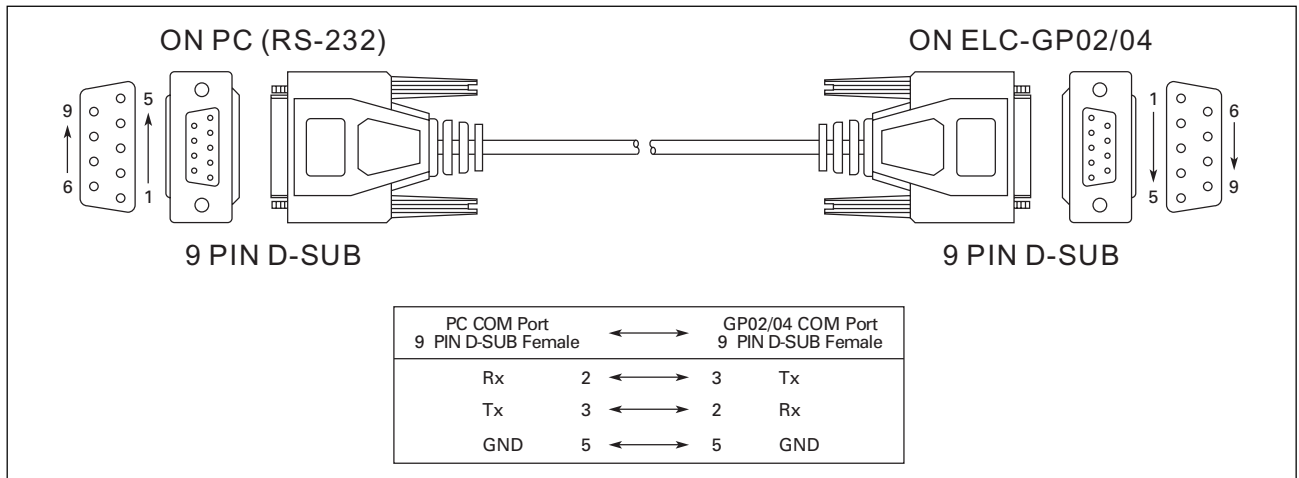

Figure 7. PC or GP02/04

ELC Controllers/Modules

Table 14. ELC Accessories

Description	Catalogue Number
24 Watt, 1 Amp Power Supply	ELC-PS01
48 Watt, 2 Amp Power Supply	ELC-PS02
Hand-Held Programmer (Includes ELC-CBHHELC15)	ELC-HHP
Cable to Connect a PC or a GP unit to ELC, 3 meters (DB9 pin female to 8 pin DIN)	ELC-CBPCELC3
Cable to Connect a PC to a GP unit. 3 meters (DB9 pin female to DB9 pin female)	ELC-CBPCEGP3
Program transfer module for GP units	ELC-GPXFERMOD
Program transfer module for ELC controllers	ELC-ACPGMXFR
Plate mount for specialty modules, qty. 10	ELC-ACCOVER
ELC Starter Kit (Includes ELC-PA10AADT, ELC-PS01, ELC-GP04, ELC-CBPCELC3, ELC-CBPCEGP3, ELCSOFT, ELCSOFT GP)	ELCSTARTKIT1

Dimensions

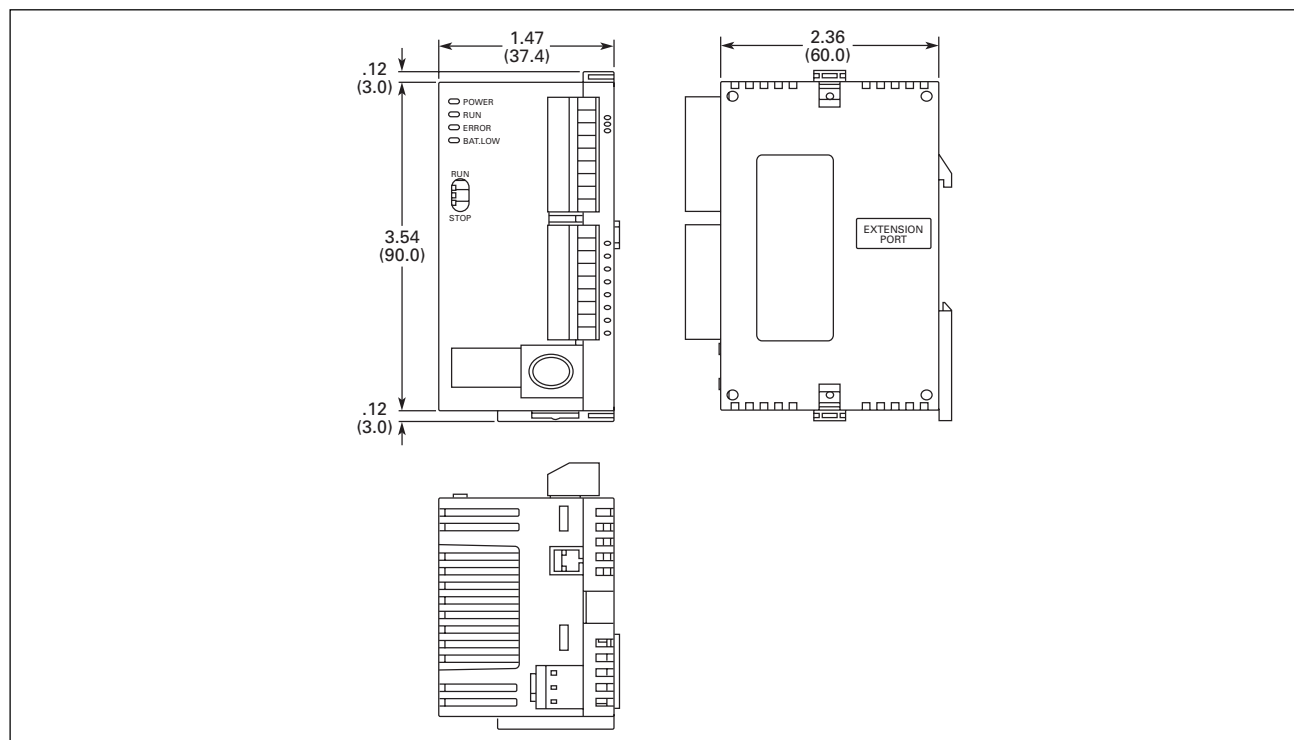

Figure 8. ELC-PA10, ELC-PC12 and ELC-PH12 Controllers — Approximate Dimensions in Inches (mm)

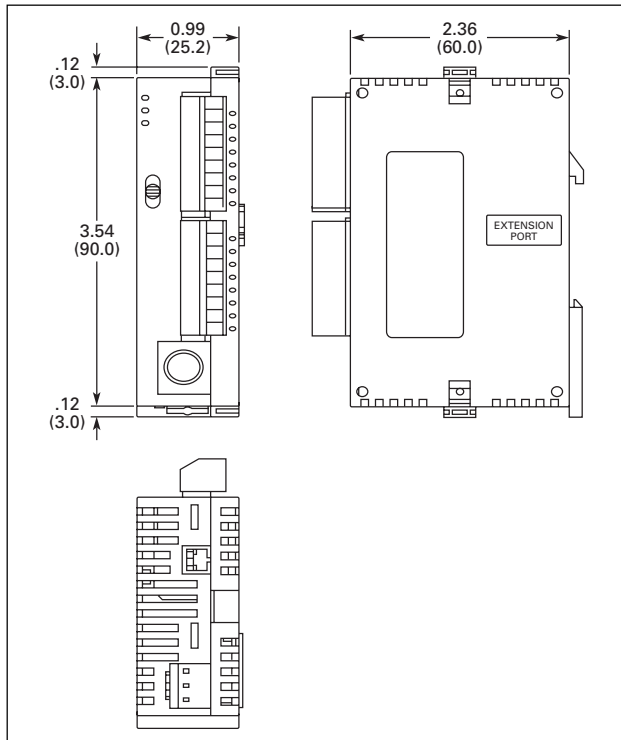

Figure 9. ELC-PB14 Controllers — Approximate Dimensions in Inches (mm)

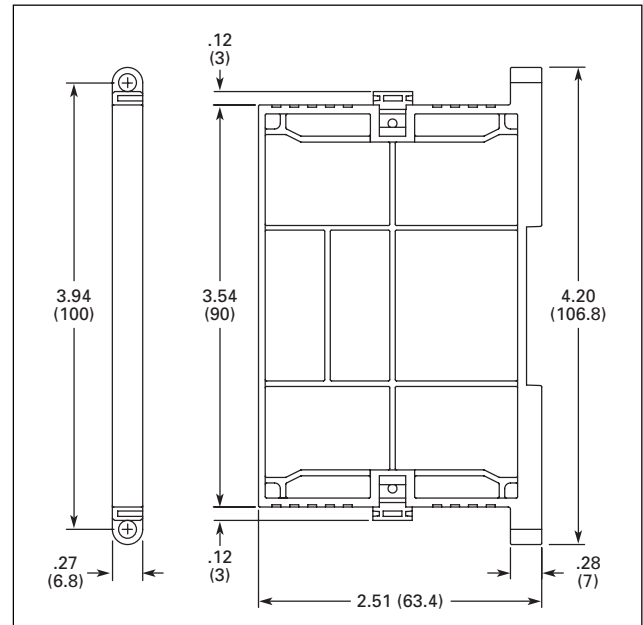

Figure 11. Plate Mount for Specialty Modules

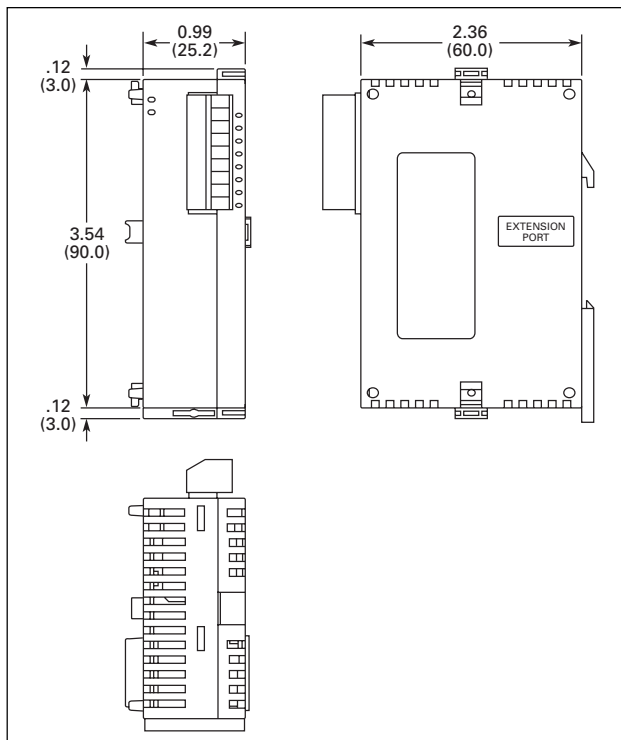
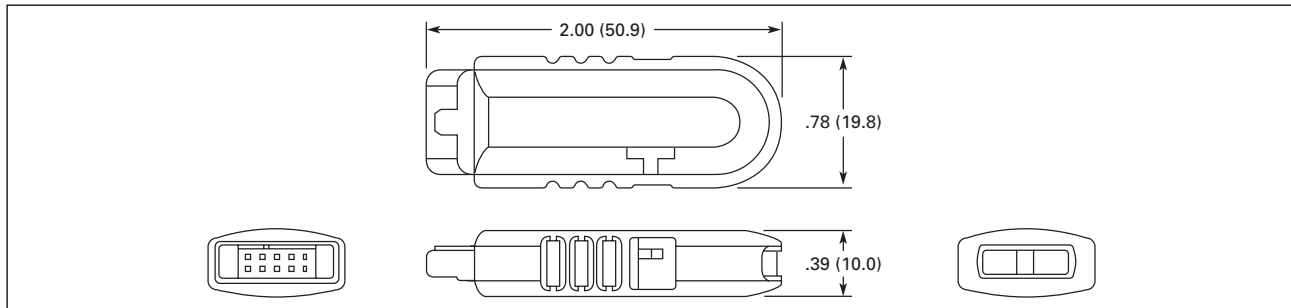
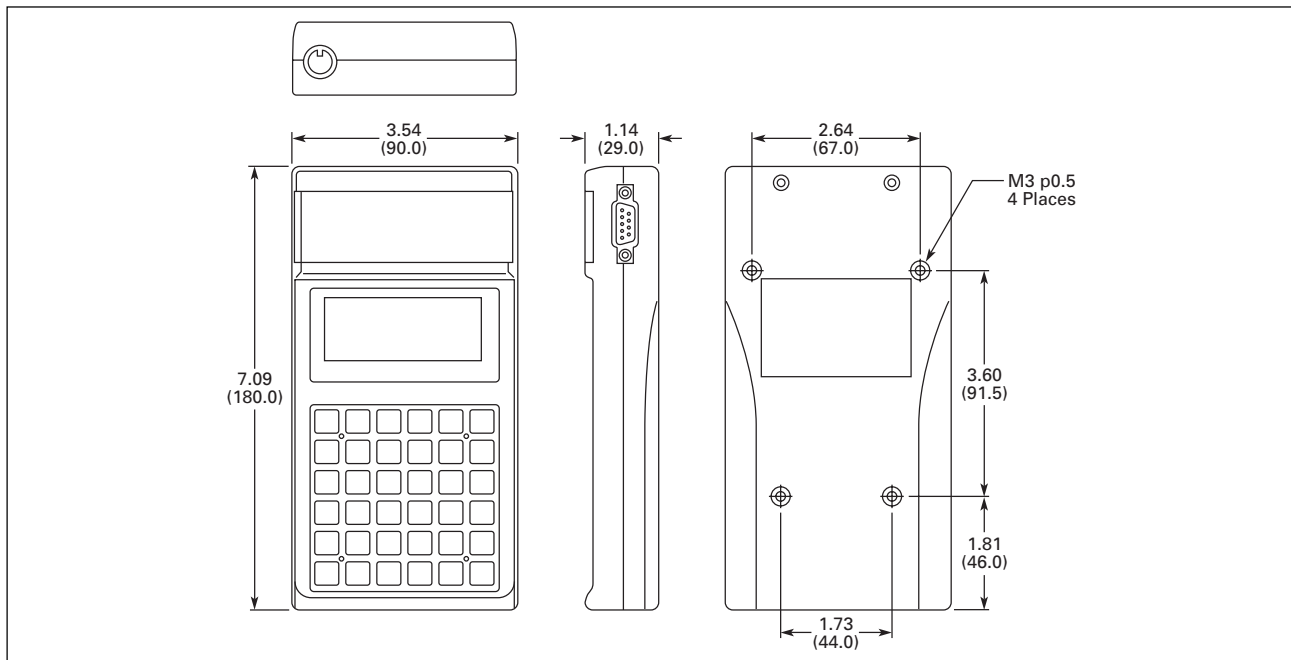

Figure 10. ELC Specialty Module — Approximate Dimensions in Inches (mm)

Figure 12. ELC-GPXFERMOD — Approximate Dimensions in Inches (mm)

Figure 13. ELC-HHP — Approximate Dimensions in Inches (mm)

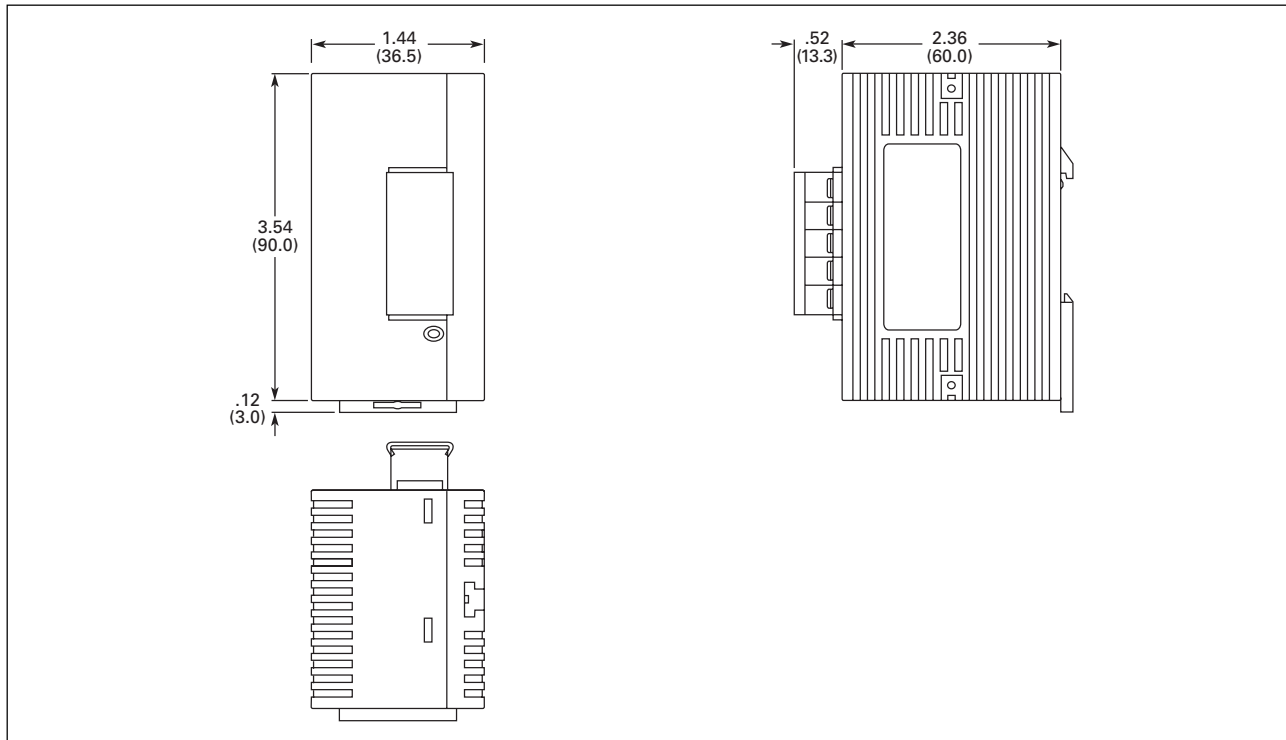

Figure 14. ELC-PS01 Power Supply — Approximate Dimensions in Inches (mm)

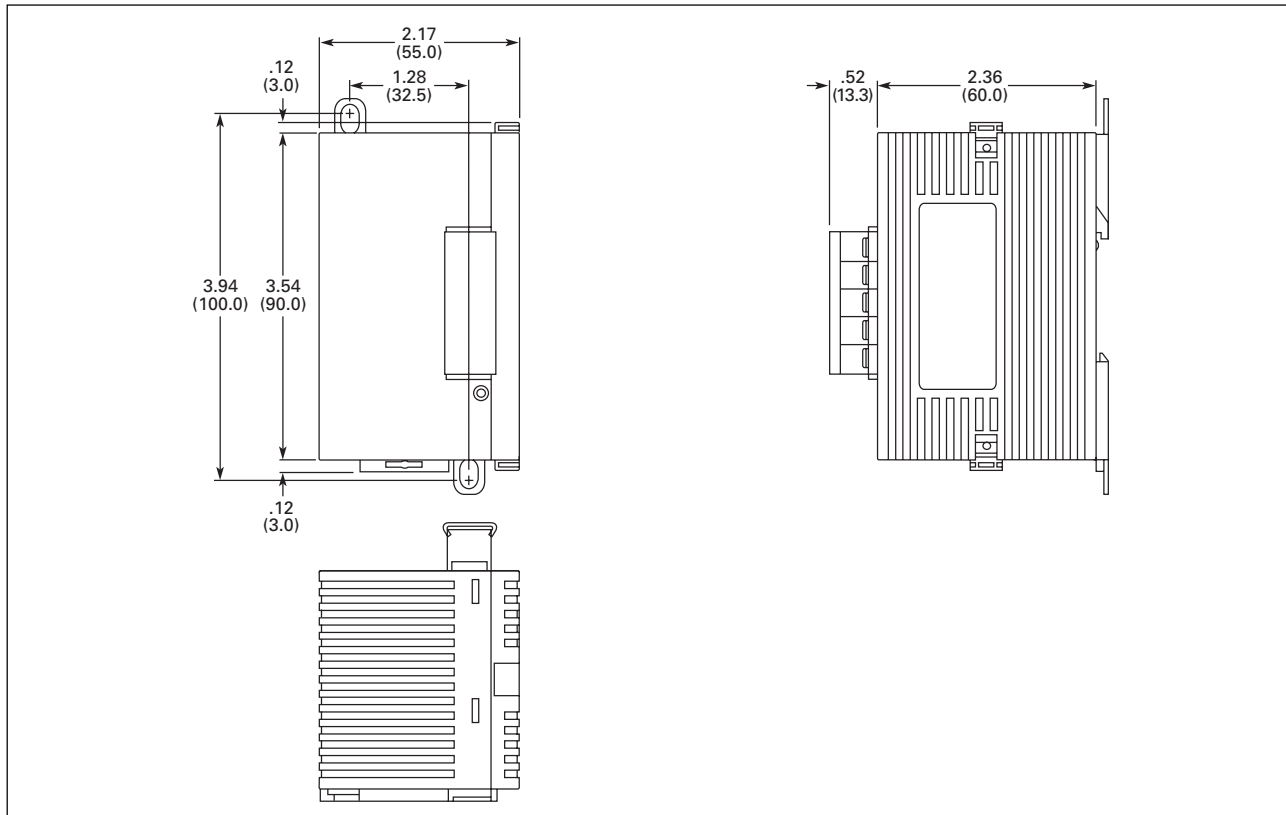

Figure 15. ELC-PS02 Power Supply — Approximate Dimensions in Inches (mm)

ELC Graphic Panels

Product Description

ELC Graphic Panels are simple to program and easily connect to ELC products. ELC graphic panels make modifying an application quick and easy. ELC graphic panels also connect to Cutler-Hammer® MVX drives, IQ MODBUS meters and many other devices. With over 30 objects that can be placed anywhere on the display, these tough panels also communicate to other major controllers. These graphic panels have two serial ports which can be used simultaneously to communicate. Transfer applications to or from these graphic panels using the handy transfer module. Ten programmable functions keys provide easy to change pages, input numeric values, enter alpha-numeric passwords, set, reset and more. Create alarms, password protect, import bitmaps, and use many different fonts.

Protocols Supported

- Eaton D50/D32LT, D320
- Eaton ELC
- Eaton MVX ASCII
- Eaton MVX RTU
- MODBUS ASCII
- MODBUS RTU
- AB DF1
- Mitsubishi FX Series
- Mitsubishi FX2N Series
- Koyo K-Sequence
- LG 200S
- OMRON C-Series
- Siemens 57-200 Series
- ASCII Slave Mode
- And more...



ELC-GP02



ELC-GP04

Features

Table 15. ELC Graphic Panel Features

Item	ELC-GP02	ELC-GP04
Display Screen		
Screen	STN-LCD	
Color	Monochromatic	
Back-light	The back-light automatic turn off time is 1 – 99 minutes (0 = do not to turn off) (back-light life is 50 thousand hours at 25°C)	
Resolution	160X32 pixels	128X64 pixels
Display Range	72 mm (W) X 22 mm (H)	67mm (W) X 32mm (H); 3.00" (diagonal preferred)
Contrast Adjustment	15-step contrast adjustment	10-step contrast adjustment
Language Font	ASCII: characters (including European Fonts) Taiwan: (BIG 5 code) traditional Chinese character font China: (GB2324-80 code) simplified Chinese character font	
Font Size (ASCII)	5 X 8, 8 X 8, 8 X 12, 8 X 16	
ALARM Indication LED	1. Power on indication (Flash three times) 2. Flash for communication error or other alarm 3. Special Indication by user programming	
RS-232 LED (Yellow)	Flashes when communicating	
RS-485 LED (Green)	Flashes when communicating	
Program Memory		
Program Memory	256KB flash memory	
External Interface		
Serial Communication Port RS-232 (COM1) 9 PIN D-SUB male	Data length: 7 or 8 bits Stop bits: 1 or 2 bits Parity: None/Odd/Even Baud Rate: 4800 bps – 115200 bps	
Extension Communication port RS-485 (COM2) 5-Pin Removal Terminal (RS-485 or RS-422)	Data length: 7 or 8 bits Stop bits: 1 or 2 bits Parity: None/Odd/Even Baud Rate: 4800 bps – 115200 bps	
Extension Slot	The slot for program copy card	
Power	24V DC input	

Product Selection

Table 16. Graphics Panels

Description	Catalogue Number
160 x 32 pixels, 10 Function Keys, Monochrome	ELC-GP02
128 x 64 pixels, 10 Function Keys, Monochrome	ELC-GP04

Standards and Certifications

Table 17. Approvals/Certifications

Description	Specifications
Electrical/EMC	
Electrostatic Discharge Immunity	EN61000-4-2/1995
Radiated Immunity	EN61000-4-3/1995
Electrical Fast Transient	EN61000-4-4/1995
Radiated Emission	CISPR22, Class A
Other Approvals	
Waterproof Class of Front Panel	IP65/NEMA Type 4
Agency Certifications	UL 508, cUL (CSA C22.2 No. 14), CE (Low Voltage Directive)

Technical Data and Specifications

Table 18. Environmental Ratings/Specifications

Description	Specification
Transportation & Storage	
Temperature	-4° – 140°F (-20° – 60°C)
Operating	
Temperature	32° – 122°F (0° – 50°C)
Humidity	20 – 90% RH (non-condensing)
Communication Interface	COM1: RS-232; COM2: RS-485/RS-422
Vibration	0.5 mm displacement, 10 – 55 Hz, X, Y, Z three directions and two hours for each direction
Impact	10G, 11 mS, from X, Y, Z three directions and three times for each direction
Weight	0.53 Lbs. (0.24 kg)
Cooling Method	Natural Air Cooling

ELC Graphic Panels

Dimensions

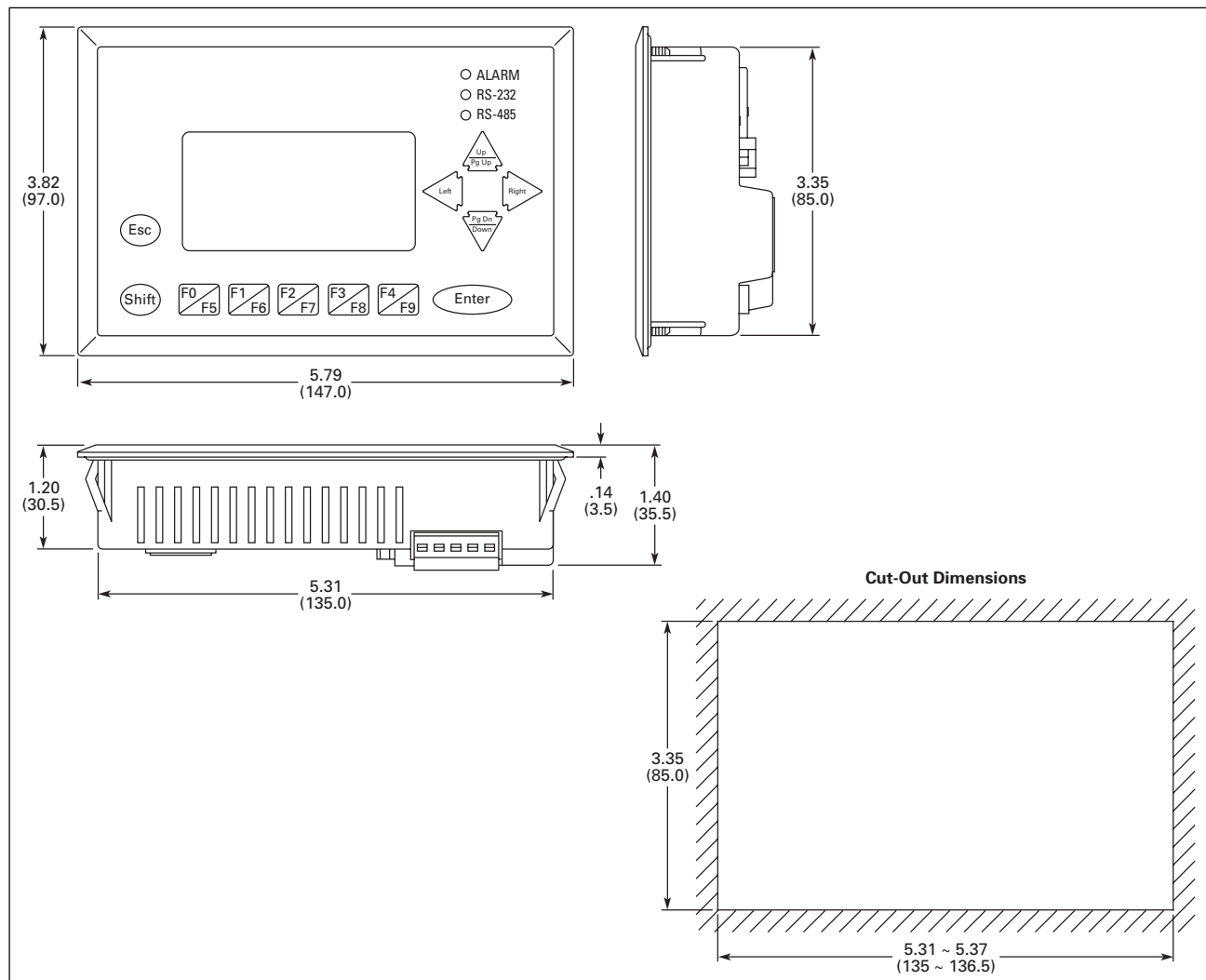

Figure 16. ECL-GP04 — Approximate Dimensions in Inches (mm)

February 2007

ELC Graphic Panels

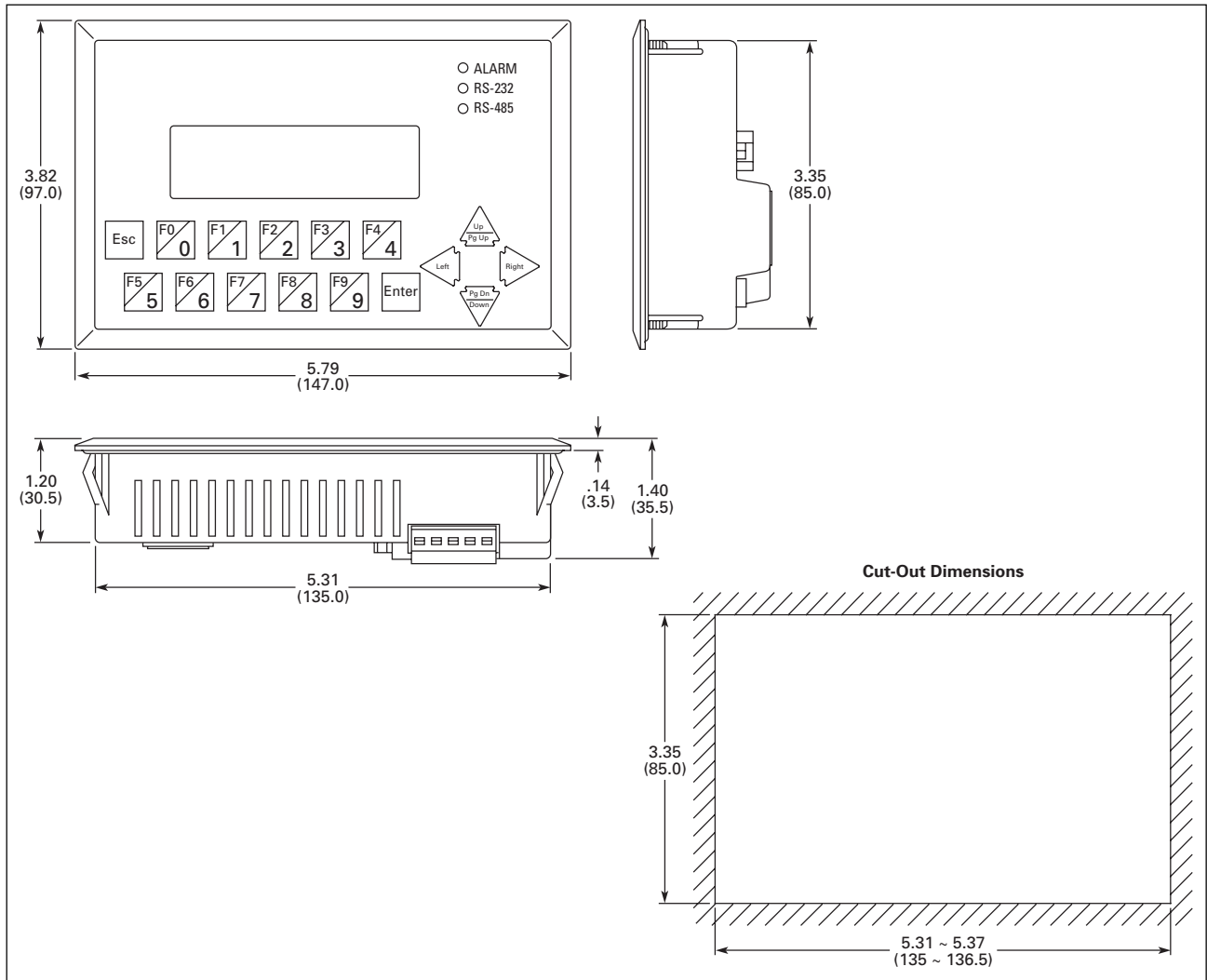

Figure 17. ECL-GP02 — Approximate Dimensions in Inches (mm)

ELC Software

ELCSoft Programming Software

ELCSoft Programming Software configures all ELC controllers. With ELCSoft, applications can be created, edited, monitored, forced, etc. Move programs from one controller to a different one with ease.

Requirements:

- **Operating Systems** – Windows 98, Windows ME, Windows 2000, Windows XP
- **Hard Drive** – At least 100M bytes
- **RAM** – At least 256M bytes



ELCSoft Ladder Diagram Mode

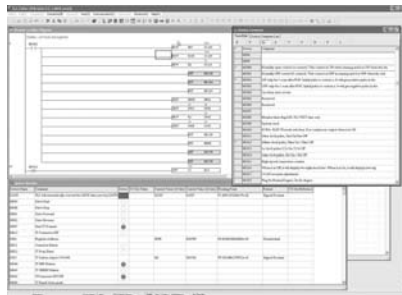

ELCSoft Editor

ELCSoftGP Programming Software

ELCSoftGP Programming Software configures all ELC graphic panels. With ELCSoftGP, applications can be created, edited, downloaded, uploaded, etc. Move programs from one controller to a different one with ease.

Requirements:

- **Operating Systems** – Windows 98, Windows ME, Windows 2000, Windows XP
- **Hard Drive** – At least 100M bytes
- **RAM** – At least 256M bytes

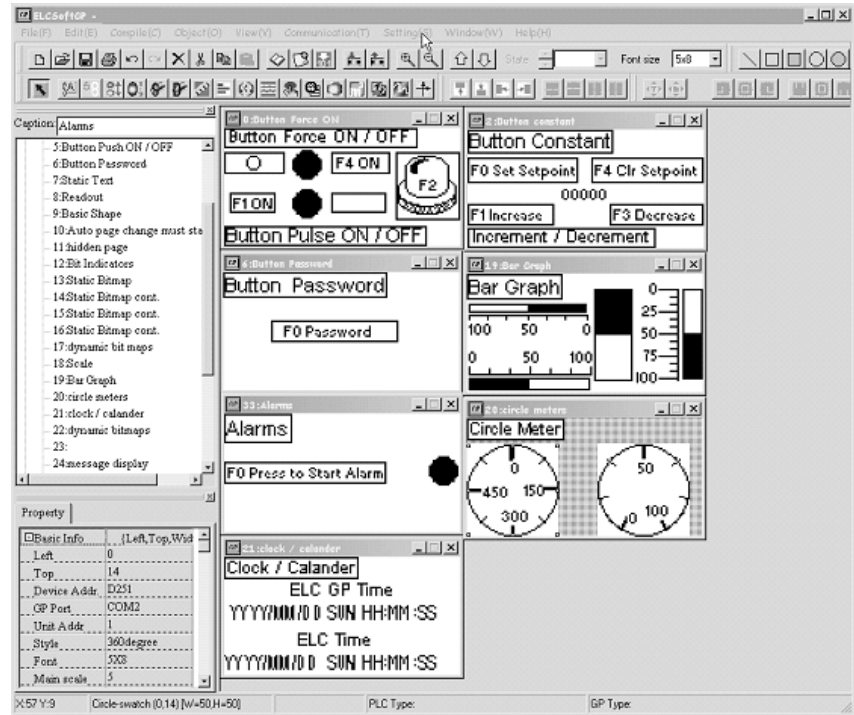

ELCSoftGP Editing Environment

Product Selection

Table 19. Software

Description	Catalogue Number
Programming Software for ELC Controllers	ELCSOFT
Programming Software for GP Units	ELCSOFTGP

February 2007

Product Family Overview

*EZ Intelligent Relays Product Family*

Product Family Overview

The EZ intelligent relays bring timers, relays, counters, special functions, inputs and outputs into one compact device that is easily configured. The EZ family of products provides exceptional levels of flexibility together with substantial savings in commissioning time and effort.

The EZ intelligent relays are available in more than 32 different styles that support from 12 I/O up to 320 I/O points providing the ideal solution for lighting, energy management, industrial control, watering, pump control, HVAC and home automation.

Once EZ products are installed, changes are easily accomplished through front panel programming, eliminating the need to change wiring and wiring diagrams increasing the savings realized.

Other terms often used for intelligent relay are relay replacer, control relay and smart relay.

Application Description

Generally where multiple relays, timers and pushbuttons are used there is an opportunity to evaluate switching to the EZ Intelligent Relays. Applications span residential, commercial and industrial installations. Typical applications are:

- Car washes.
- Automatic door control.
- Commercial lighting.
- Residential lighting.
- Exterior lighting.
- Pump control, 12V DC automotive control.
- Greenhouse control.
- Crane control.
- Machinery.
- Paper/pulp.
- Elevator control.
- Livestock feed/gate control.
- Irrigation control.
- Cart chargers.
- Heating and air conditioning.

EZ 500/700/800/EZD Intelligent Relays

EZ 500/700/800/EZD Intelligent Relays

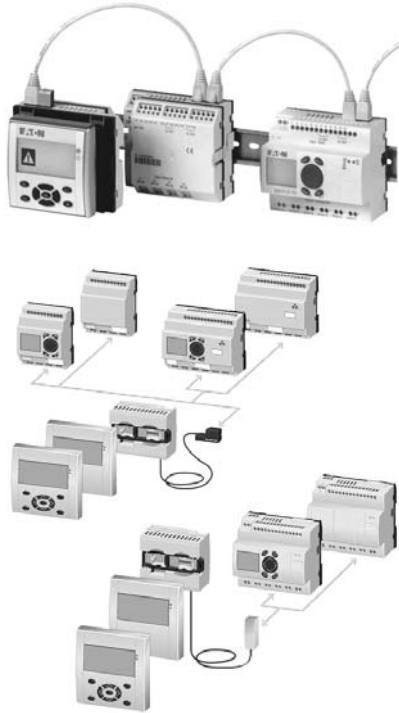

EZ 500/700/800/EZD Intelligent Relays

Product Description

Four families make up the EZ Intelligent Relay product line.

EZ500 Series — for controlling small applications with up to 12 input/output signals. Models are available with and without displays. DIN rail mounted.

EZ700 Series — for controlling medium-sized applications with up to 40 input/output signals. DIN rail mounted.

EZ800 Series — for controlling large-scale applications with up to 320 input/output signals. Models are available with and without displays. DIN rail mounted.

EZD Series — for controlling large-scale applications with up to 320 input/output signals using powerful visualization functions. The EZD display can be linked to the EZ500/700/800 models to provide an enhanced operator interface. Panel mounted.

The **EZ-NET** integrated network called provides easy and inexpensive linking of up to eight EZ800/EZD devices over a distance of up to 1000 meters. The EZ and EZD devices can run their own program or be used as a distributed input/output module.

Catalogue Number Selection

Table 20. EZ500/700/800 Module Definition Catalogue Numbering System

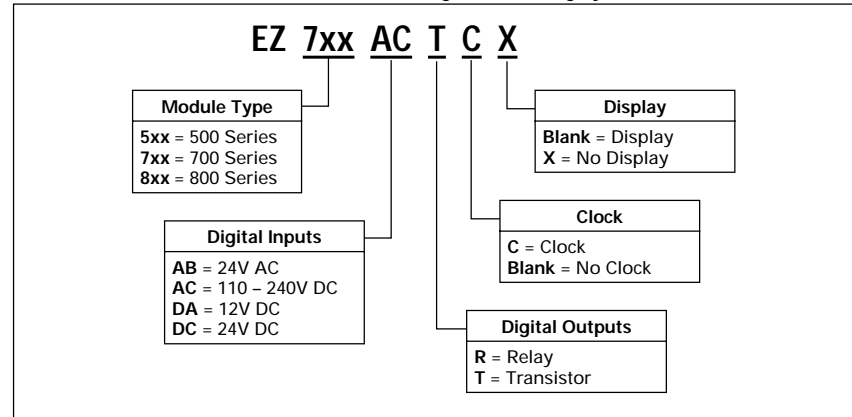

Product Selection



EZ500 with Display



EZ500 without Display

Table 21. EZ500 Intelligent Relays

Description	Inputs					Outputs		Catalogue Number
	24V AC	110 - 240V AC	12V DC	24V DC	ALG	RY	TRN	
12 I/O, Clock, Display	8	—	—	—	2	4	—	EZ512-AB-RC
12 I/O, Clock, No Display	8	—	—	—	2	4	—	EZ512-AB-RCX
12 I/O, No Clock, Display	—	8	—	—	—	4	—	EZ512-AC-R
12 I/O, Clock, Display	—	8	—	—	—	4	—	EZ512-AC-RC
12 I/O, Clock, No Display	—	8	—	—	—	4	—	EZ512-AC-RCX
12 I/O, Clock, Display	—	—	8	—	2	4	—	EZ512-DA-RC
12 I/O, Clock, No Display	—	—	8	—	2	4	—	EZ512-DA-RCX
12 I/O, No Clock, Display	—	—	—	8	2	4	—	EZ512-DC-R
12 I/O, Clock, Display	—	—	—	8	2	4	—	EZ512-DC-RC
12 I/O, Clock, No Display	—	—	—	8	2	4	—	EZ512-DC-RCX
12 I/O, Clock, Display	—	—	—	8	2	—	4	EZ512-DC-TC
12 I/O, Clock, No Display	—	—	—	8	2	—	4	EZ512-DC-TCX

Note: Analogue inputs selectable. Selection will reduce number of digital inputs.

EZ 500/700/800/EZD Intelligent Relays



EZ700 with Display



EZ700 without Display

Table 22. EZ700 Intelligent Relays

Description	Inputs					Outputs		Catalogue Number
	24V AC	110 – 240V AC	12V DC	24V DC	Analogue	Relay	Transistor	
18 I/O, Clock, Display	12	—	—	—	4	6	—	EZ719-AB-RC
18 I/O, Clock, No Display	12	—	—	—	4	6	—	EZ719-AB-RCX
18 I/O, Clock, Display	—	12	—	—	—	6	—	EZ719-AC-RC
18 I/O, Clock, No Display	—	12	—	—	—	6	—	EZ719-AC-RCX
18 I/O, Clock, Display	—	—	12	—	4	6	—	EZ719-DA-RC
18 I/O, Clock, No Display	—	—	12	—	4	6	—	EZ719-DA-RCX
18 I/O, Clock, Display	—	—	—	12	4	6	—	EZ719-DC-RC
18 I/O, Clock, No Display	—	—	—	12	4	6	—	EZ719-DC-RCX
20 I/O, Clock, Display	—	—	—	12	4	—	8	EZ721-DC-TC
20 I/O, Clock, No Display	—	—	—	12	4	—	8	EZ721-DC-TCX

Note: Analogue inputs selectable. Selection will reduce the number of digital inputs.



EZ800 with Display



EZ800 without Display

Table 23. EZ800 Intelligent Relays

Description	Inputs			Outputs			Catalogue Number
	110 – 240V AC	24V DC	Analogue	Relay	Transistor	Analogue	
18 I/O, Clock, Display	12	—	—	6	—	—	EZ819-AC-RC
18 I/O, Clock, No Display	12	—	—	6	—	—	EZ819-AC-RCX
18 I/O, Clock, Display	—	12	4	6	—	—	EZ819-DC-RC
18 I/O, Clock, No Display	—	12	4	6	—	—	EZ819-DC-RCX
19 I/O, Clock, Display	—	12	4	6	—	1	EZ820-DC-RC
19 I/O, Clock, No Display	—	12	4	6	—	1	EZ820-DC-RCX
20 I/O, Clock, Display	—	12	4	—	8	—	EZ821-DC-TC
20 I/O, Clock, No Display	—	12	4	—	8	—	EZ821-DC-TCX
21 I/O, Clock, Display	—	12	4	—	8	1	EZ822-DC-TC
21 I/O, Clock, No Display	—	12	4	—	8	1	EZ822-DC-TCX

Note: Analogue inputs selectable. Selection will reduce the number of digital inputs.

EZ 500/700/800/EZD Intelligent Relays



EZD-80



EZD-CP8



EZD I/O



EZD Assembly

Table 24. EZD Displays (EZD-80) and EZD Controllers (EZD-CP8)

Description	Catalogue Number
EZD, No Buttons	EZD-80
EZD, Buttons	EZD-80-B
EZD CPU with 24V DC, Power Supply, Clock	EZD-CP8-ME
EZD CPU with 24V DC, Power Supply, Clock, EZ-Net	EZD-CP8-NT
EZD CPU with 100 – 240V AC, Power Supply, Clock	EZD-AC-CP8-ME
EZD CPU with 100 – 240V AC, Power Supply, Clock, EZ-Net	EZD-AC-CP8-NT



EZD-CP4-800 Attached to EZ-80 Display and EZ800 Unit

Table 25. EZD Display to EZ Communication Modules (EZD-CP4)

Description	Catalogue Number
EZD Display to EZ500/700 Communication Module with EZ500/700 Communication Cable (EZD-CP4-500-CAB5)	EZD-CP4-500
EZD Display to EZ800 Communication Module with EZ800 Communication Cable (EZD-CP4-800-CAB5)	EZD-CP4-800

Technical Data and Specifications

Table 26. EZ500 Series

Type	EZ512-AB...	EZ512-AC...	EZ512-DA...	EZ512-DC-R...	EZ512-DC-TC.
Supply Voltage	24V AC	100 – 240V AC	12V DC	24V DC	24V DC
Heat Dissipation	5 VA	5 VA	2 W	2 W	2 W
Continuous Current Outputs (1)	8 A	8 A	8 A	8 A	0.5 A
Short-circuit Proof with Power Factor 1	Line Protection B16, 600 A				—
Short-circuit Proof with Power Factor 0.7...0.7	Line Protection B16, 900 A				—
Mounting	On Top-hat Rail to DIN 50022, 35 mm or Screw Mounting with EZB4-101-GF1 Fixing Brackets				

Table 27. EZ700 Series

Type	EZ719-AB...	EZ719-AC...	EZ719-DA...	EZ719-DC-RC.	EZ721-DC-TC.
Supply Voltage	24V AC	100 – 240V AC	12V DC	24V DC	24V DC
Heat Dissipation	7 VA	10 VA	3.5 W	3.5 W	3.5 W
Continuous Current Outputs (1)	8 A	8 A	8 A	8 A	0.5 A
Short-circuit Proof with Power Factor 1	Line protection B16, 600 A				—
Short-circuit Proof with Power Factor 0.7...0.7	Line protection B16, 900 A				—
Mounting	On Top-hat Rail to DIN 50022, 35 mm or Screw Mounting with EZB4-101-GF1 Fixing Brackets				

Table 28. EZ800 Series

Type	EZ819-AC...	EZ819-DC-RC.	EZ820-DC-RC.	EZ821-DC-TC.	EZ822-DC-TC.
Supply Voltage	100 – 240V AC	24V DC	24V DC	24V DC	24V DC
Heat Dissipation	10 VA	3.4 W	3.4 W	3.4 W	3.4 W
Continuous Current Outputs (1)	8 A	8 A	8 A	8 A	0.5 A
Short-circuit Proof with Power Factor 1	Line protection B16, 600 A				—
Short-circuit Proof with Power Factor 0.7...0.7	Line protection B16, 900 A				—
Mounting	On Top-hat Rail to DIN 50022, 35 mm or Screw Mounting with EZB4-101-GF1 Fixing Brackets				

Table 29. EZD CP4 and CP8 Modules

Type	EZD-80...	EZD-CP4-...	EZD-CP8...	EZD-AC-CP8...
Supply Voltage	Supply from -CP	24V DC	24V DC	100 – 240V AC
Heat Dissipation	3 W	1.5 W	3 W	8 VA
Mounting	Front Mounting in 2 x 22.5 mm Standard Drill Holes	Snap Fitted to EZD-80	Snap Fitted to EZD-80 or on Top-hat Rail to DIN 50022, 35 mm or Screw Mounting with EZB4-101-GF1 Fixing Brackets	

Table 30. EZ500, EZ700, EZ800, EZD-80, EZD-CP4, EZD-CP8 Modules

Type	EZD-80...	EZ500/700/800, EZD-CP4/CP8
Connection Cables	—	0.2 – 4.0 mm ² (AWG 22-12), solid 0.2 - 2.5 mm ² (AWG 22-12), flexible
Degree of Protections	IP65	IP 20
RFI Suppression	EN 55011, EN 55022 Class B, IEC 61000-6-1,2,3,4	EN 55011, EN 55022 Class B, IEC 61000-6-1,2,3,4
Ambient Operating Temperature	Clearly Legible at -5 to 50°C	-25 to 55°C
Transport and Storage Temperature	-40 to 70°C	-40 to 70°C
Certification, Standards	EN 50178, IEC/EN 60947, ULT, CSAT	EN 50178, IEC/EN 60947, UL, CSA

Dimensions

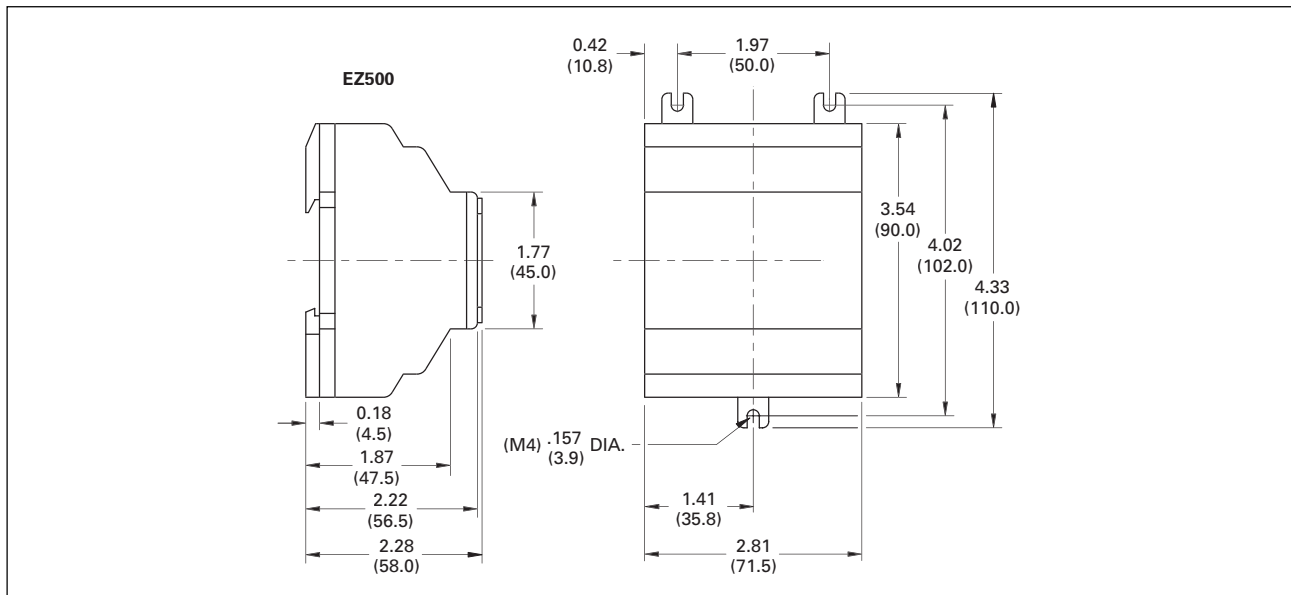

Figure 18. EZ500 Series Dimensions in Inches (mm), Drawing Number MD05013001E

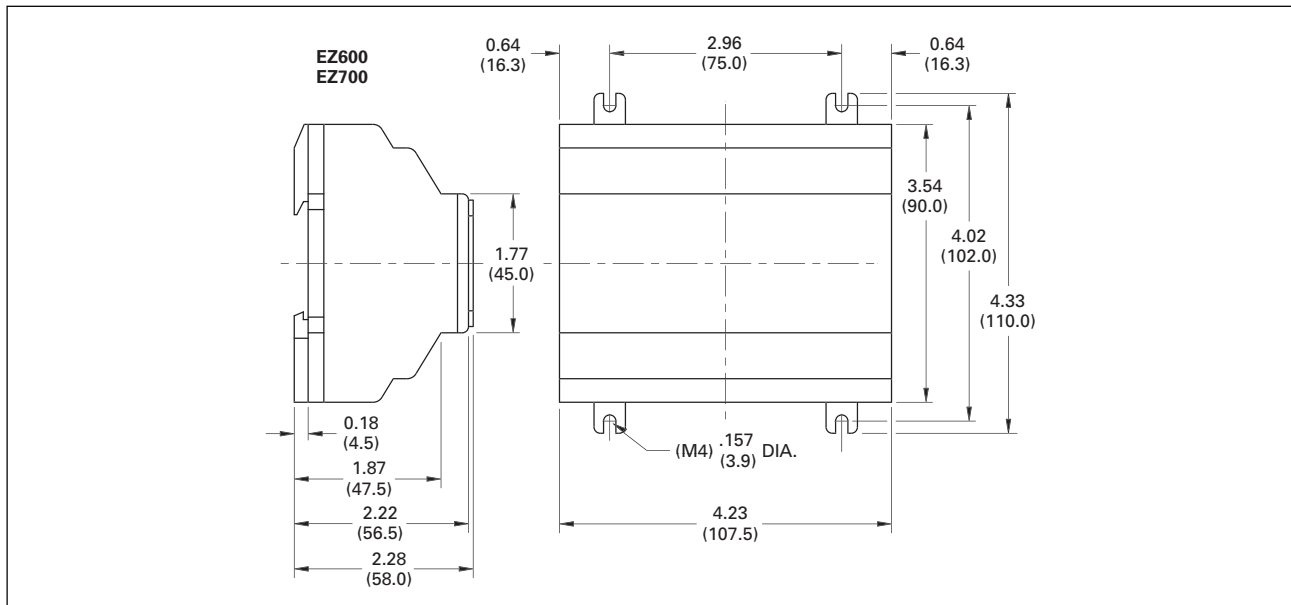

Figure 19. EZ600 and EZ700 Series Dimensions in Inches (mm), Drawing Number MD05013002E

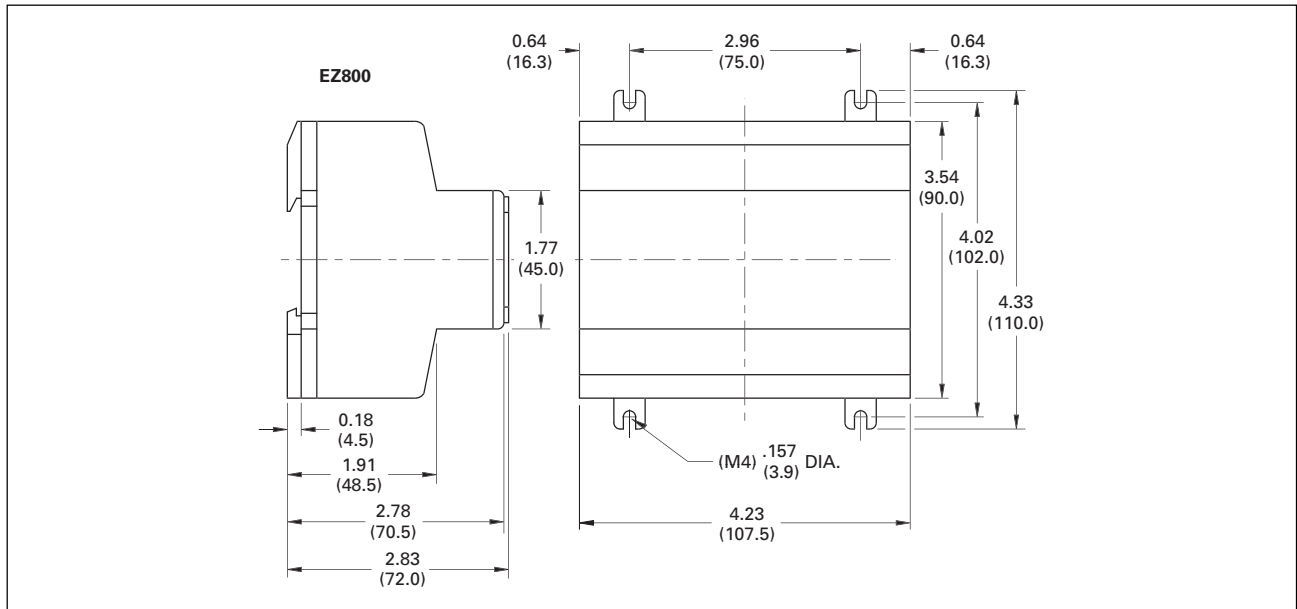

Figure 20. EZ800 Series Dimensions in Inches (mm), Drawing Number MD05013003E

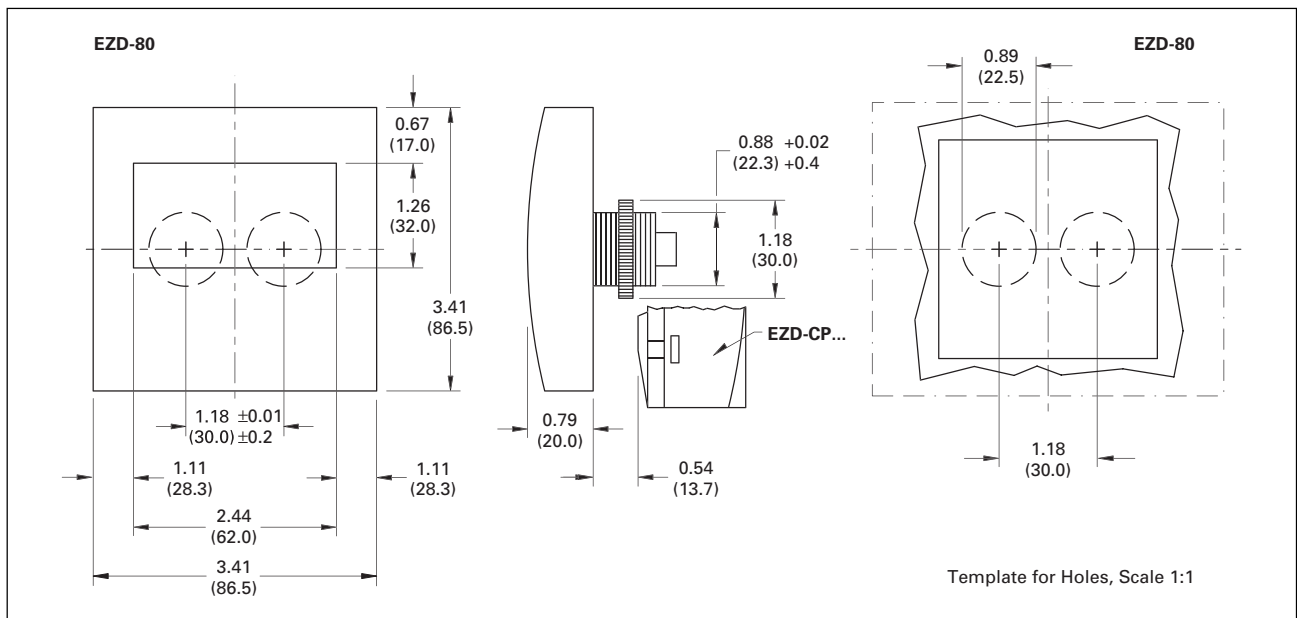

Figure 21. EZD-80 Series Dimensions in Inches (mm), Drawing Number MD05013005E

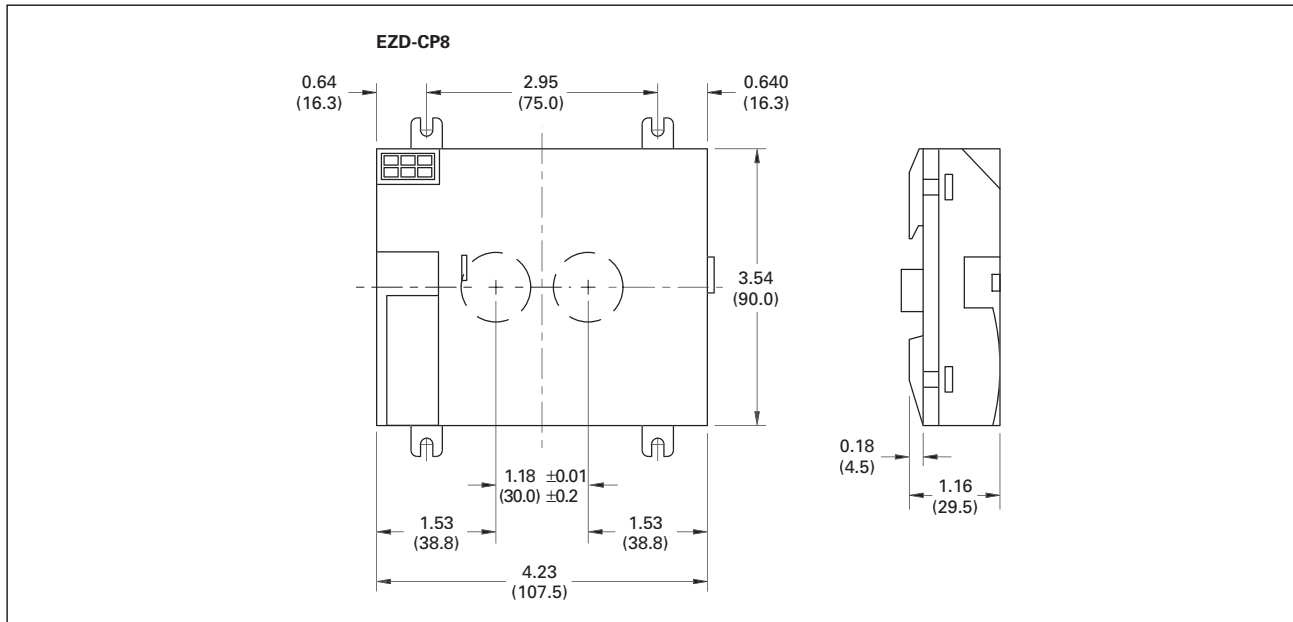

Figure 22. EVD-CP8 Series Dimensions in Inches (mm), Drawing Number MD05013006E

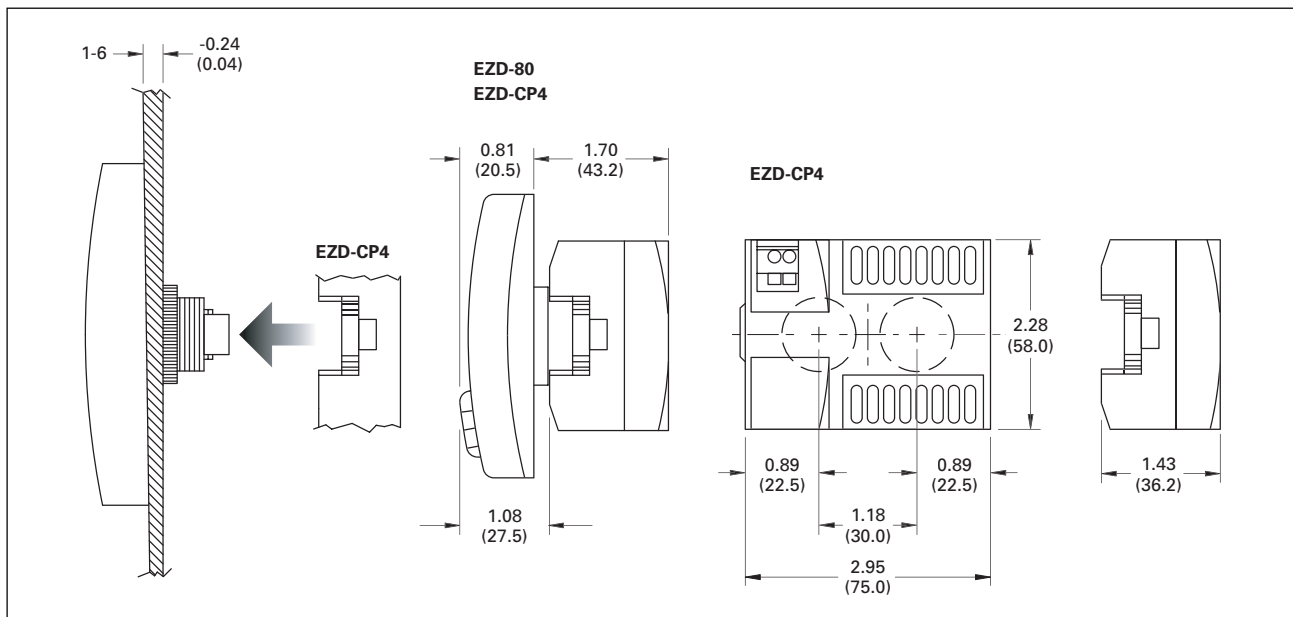

Figure 23. EVD-CP4, EVD-80 and EVD-CP4 Series Combined Dimensions in Inches (mm), Drawing Number MD013013E

EZD Controller I/O Modules

Product Selection

Table 31. EZD Controller I/O Modules

Description	Inputs			Outputs			Catalogue Number
	110 – 240V AC	24V DC	Analogue	Relay	Transistor	Analogue	
16 I/O	12	—	—	4	—	—	EZD-AC-R16 EZD-R16 EZD-RA17
16 I/O	—	12	4	4	—	—	
17 I/O	—	12	4	4	—	1	
16 I/O	—	12	4	—	4	—	EZD-T16 EZD-TA17
17 I/O	—	12	4	—	4	1	

Note: Analogue inputs selectable. Selection will reduce the number of digital inputs.

Technical Data and Specifications

Table 32. EZD Specifications

Type	EZD-AC-R16	EZD-R16	EZD-RA17	EZD-T16	EZD-TA17
Supply Voltage	Supply via EZD-CP8 module				
Heat Dissipation	0.5 W	0.5 W	0.5 W	0.5 W	0.5 W
Continuous Current Outputs ¹	8 A	8 A	8 A	0.5 A	0.5 A
Short-circuit Proof with Power Factor 1	Line protection B16, 600 A			—	—
Short-circuit Proof with Power Factor 0.7...0.7	Line protection B16, 900 A			—	—
Connection Cables	0.2 – 4.0 mm ² (AWG 22-12), Solid 0.2 – 2.5 mm ² (AWG 22-12), Flexible				
Degree of Protections	IP 20	IP 20	IP 20	IP 20	IP 20
RFI Suppression	EN 55011, EN 55022 Class B, IEC 61000-6-1,2,3,4				
Ambient Operating Temperature	-25 to 55°C	-25 to 55°C	-25 to 55°C	-25 to 55°C	-25 to 55°C
Transport and Storage Temperature	-40 to 70°C	-40 to 70°C	-40 to 70°C	-40 to 70°C	-40 to 70°C
Certification, Standards	EN 50178, IEC/EN 60947, UL, CSA				
Mounting	Snap Fitted to EZD-CP8 Module				

¹ Relay = 8 A (10 A to UL) with resistive load, 3 A with inductive load/transistor outputs = 0.5 A/24V DC, max 4 outputs switchable in parallel.

Dimensions

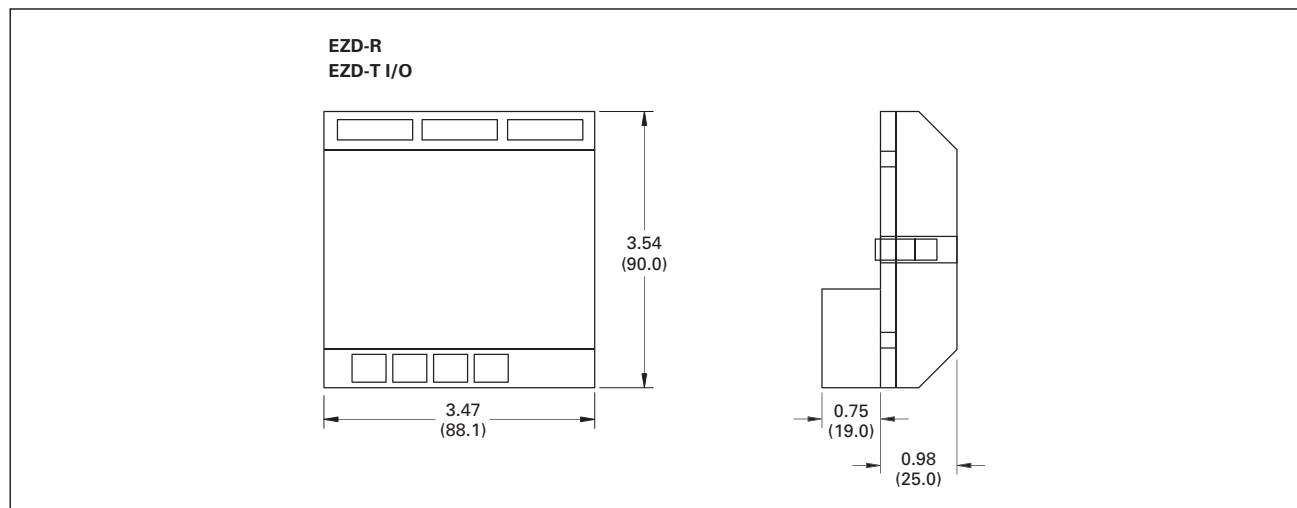
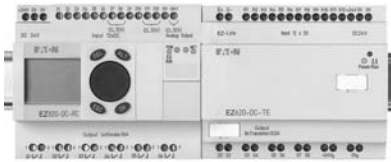

Figure 24. EZD-R/EZD-T I/O Module Dimensions in Inches (mm), Drawing Number MD05013007E

EZ/EZD Expansion Modules

EZ/EZD Expansion Modules



EZ/EZD Expansion Modules

Product Description

Expansion modules are available for increasing the input/output of the EZ700/800 and EZD intelligent relays to 24 inputs and up to 16 outputs. Expansion modules can be mounted directly to the EZ/EZD unit or up to 98 ft. (30 m) away using coupling module EZ200-EZ.

Product Selection

Table 33. EZ/EZD I/O Expansion Modules

Description	Inputs		Outputs		Catalogue Number
	110 – 240V AC	24V DC	RY	TRN	
2 I/O Expansion	—	—	2	—	EZ202-RE
18 I/O Expansion	12	—	6	—	EZ618-AC-RE
18 I/O Expansion	—	12	6	—	EZ618-DC-RE
20 I/O Expansion	—	12	—	8	EZ620-DC-TE
Coupling Module for Remote Mounting of Expansion Modules					EZ200-EZ

Technical Data and Specifications

Table 34. EZ Specifications

Type	EZ202-RE	EZ618-AC-RE	EZ618-DC-RE	EZ620-DC-TE	EZ200EZ
Supply Voltage	—	100 – 240V AC	24V AC	24V AC	—
Heat Dissipation	1 W	10 VA	4 W	4 W	1 W
Continuous Current Outputs ¹	8 A	8 A	8 A	0.5 A	—
Short-circuit Proof with Power Factor 1	Line Protection B16, 600 A				—
Short-circuit Proof with Power Factor 0.7...0.7	Line Protection B16, 900 A				—
Connection Cables	0.2 – 4.0 mm ² (AWG 22-12), Solid 0.2 – 2.5 mm ² (AWG 22-12), Flexible				
Degree of Protections	IP 20	IP 20	IP 20	IP 20	IP 20
RFI Suppression	EN 55011, EN 55022 Class B, IEC 61000-6-1,2,3,4				
Ambient Operating Temperature	-25 to 55°C	-25 to 55°C	-25 to 55°C	-25 to 55°C	-25 to 55°C
Transport and Storage Temperature	-40 to 70°C	-40 to 70°C	-40 to 70°C	-40 to 70°C	-40 to 70°C
Certification, Standards	EN 50178, IEC/EN 60947, UL, CSA				
Mounting	On Top-hat Rail to DIN 50022, 35 mm or Screw Mounting with EZB4-101-GF1 Fixing Brackets				

¹ Relay = 8A (10 A to UL) with resistive load, 3 A with inductive load/transistor outputs = 0.5 A/24V DC, max 4 outputs switchable in parallel.

Dimensions

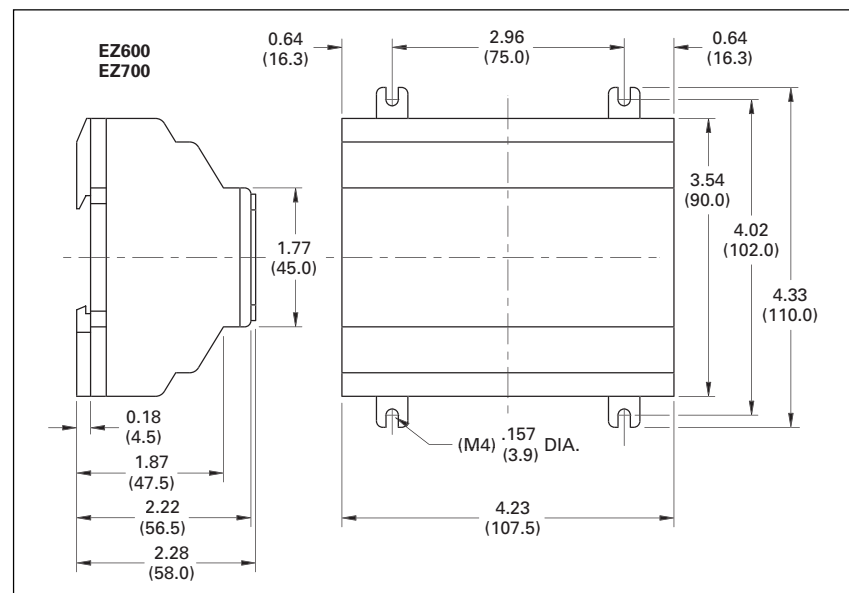

Figure 25. EZ600 and EZ700 Series Dimensions in Inches (mm), Drawing Number MD05013002E

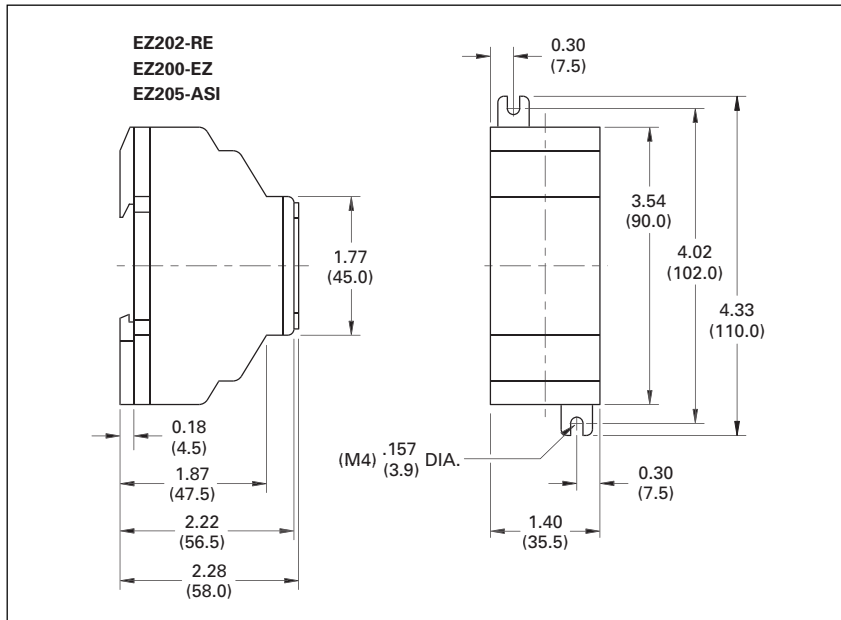

Figure 26. EZ202-RE/EZ200-EZ/EZ205-ASI Series Dimensions in Inches (mm), Drawing Number MD05013012E

EZ/EZD Communication Modules



EZ204-DP Communication Module

Product Description

Four modules are available for easily connecting to world-standard networks. The communication modules can be used with the EZ700/800 and EZD intelligent relays.

Available communication modules support:

- PROFIBUS-DP.
- AS-I (Actuator Sensor Interface) networks.
- CANopen.
- DeviceNet.

All modules act as a gateway and operate exclusively as a slave station on the network.

Product Selection

Table 35. EZ/EZD Communication Interface Modules

Description	Catalogue Number
PROFIBUS-DP Slave Interface Module	EZ204-DP
AS-Interface Slave with 4 In and 4 Out Interface Module	EZ205-ASI
CANopen Interface Module	EZ221-CO
DeviceNet Slave Interface Module	EZ222-DN

Technical Data and Specifications

Table 36. EZ/EZD Specifications

Type	EZ204-DP	EZ205-ASI	EZ221-CO	EZ222-DN
Supply Voltage	24V DC	24V DC	24V DC	24V DC
Heat Dissipation	2 W	1 W	1 W	1 W
Connection Cables	0.2 – 4.0 mm ² (AWG 22-12), Solid 0.2 – 2.5 mm ² (AWG 22-12), Flexible			
Degree of Protections	IP 20	IP 20	IP 20	IP 20
RFI Suppression	EN 55011, EN 55022 Class B, IEC 61000-6-1,2,3,4			
Ambient Operating Temperature	-25 to 55°C	-25 to 55°C	-25 to 55°C	-25 to 55°C
Transport and Storage Temperature	-40 to 70°C	-40 to 70°C	-40 to 70°C	-40 to 70°C
Certification, Standards	EN 50178, IEC/EN 60947, UL, CSA			
Mounting	On Top-hat Rail to DIN 50022, 35 mm or Screw Mounting with EZB4-101-GF1 Fixing Brackets			

Dimensions

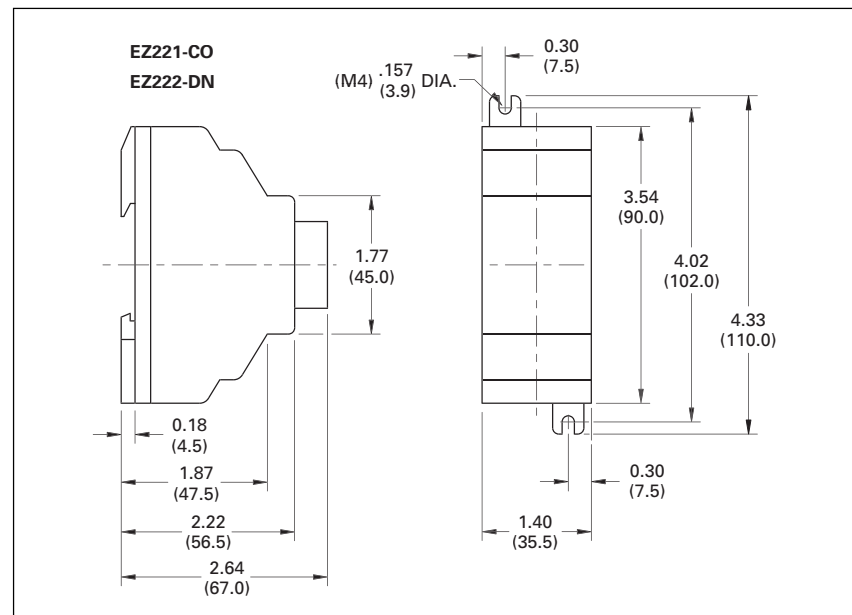

Figure 27. EZ221-CO/EZ222-DN Series Dimensions in Inches (mm), Drawing Number MD05013010E

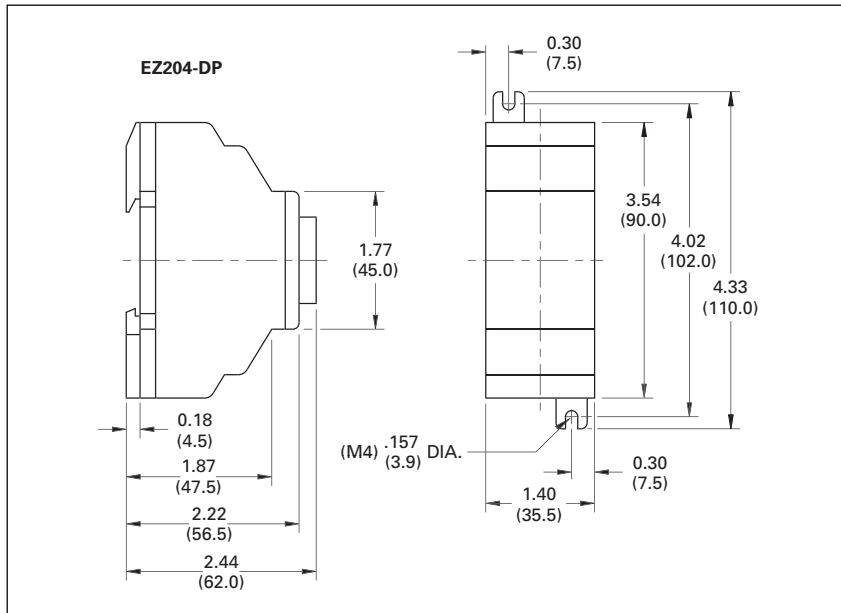

Figure 28. EZ204-DP Series Dimensions in Inches (mm), Drawing Number MD05013011E

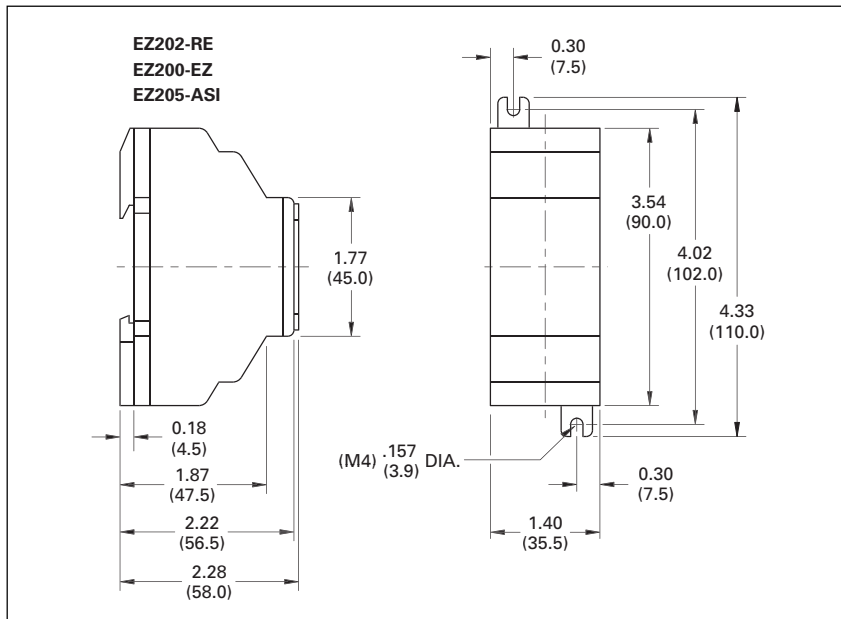

Figure 29. EZ202-RE/EZ200-EZ/EZ205-ASI Series Dimensions in Inches (mm), Drawing Number MD05013012E

EZ Software



EZSoft Software

Product Description

The EZSoft software is used to program all of the EZ and EZD controllers and displays. The Windows-based software provides straightforward circuit diagram input and editing and the diagrams can be displayed in the format desired. When EZ800 and EZD controllers are connected using EZ-NET, all connected devices can be accessed and their programs loaded from a single controller.

EZSoft includes an integrated offline simulation tool that allows users to test a circuit diagram before commissioning.

Product Selection

Table 37. EZ/EZD Software

Description	Catalogue Number
Programming Software for EZ500/700/800 and EZD	EZSOFT

EZ/EZD Power Supplies

Product Selection

Table 38. EZ/EZD-CP8 Power Supplies

Description	Catalogue Number
100 – 240V AC Input to 12V DC at 20 mA/24V DC at 250 mA	EZ200-POW
100 – 240V AC Input to 24V DC at 1.25 A	EZ400-POW

Technical Data and Specifications

Table 39. EZ Specifications

Type	EZ200-POW	EZ400-POW
Supply Voltage	100 – 240V AC	100 – 240V AC
Maximum Range	85 – 264V AC	85 – 264V AC
Output Voltage	24V DC ($\pm 3\%$)	24V DC ($\pm 3\%$)
Output Current (Rated Value)	0.25 A	1.25 A
Overcurrent Limitation Form	0.3 A	1.4 A
Short-circuit Proof (Secondary)	YES	YES
Overload Proof	YES	YES
Potential Isolation (prim/sec.)	YES, SELV, (to EN 600950, VDE 805)	YES, SELV, (to EN 600950, VDE 805)
Others	Additional Output Voltage 12 dc, 20 mA	Additional Output Voltage 12 dc, 20 mA
Connection Cables	0.2 – 4.0 mm ² (AWG 22-12), Solid 0.2 – 2.5 mm ² (AWG 22-12), Flexible	0.2 – 4.0 mm ² (AWG 22-12), Solid 0.2 – 2.5 mm ² (AWG 22-12), Flexible
Degree of Protections	IP 20	IP 20
RFI Suppression	EN 55011, EN 55022 Class B, IEC 61000-6-1, 2, 3, 4	EN 55011, EN 55022 Class B, IEC 61000-6-1, 2, 3, 4
Ambient Operating Temperature	-25 to 55°C	-25 to 55°C
Transport and Storage Temperature	-40 to 70°C	-40 to 70°C
Certification, Standards	EN 50178, IEC/EN 60947, UL, CSA	EN 50178, IEC/EN 60947, UL, CSA
Mounting	On Top-hat Rail to DIN 50022, 35 mm or Screw Mounting with EZB4-101-GF1 Fixing Brackets	

Dimensions

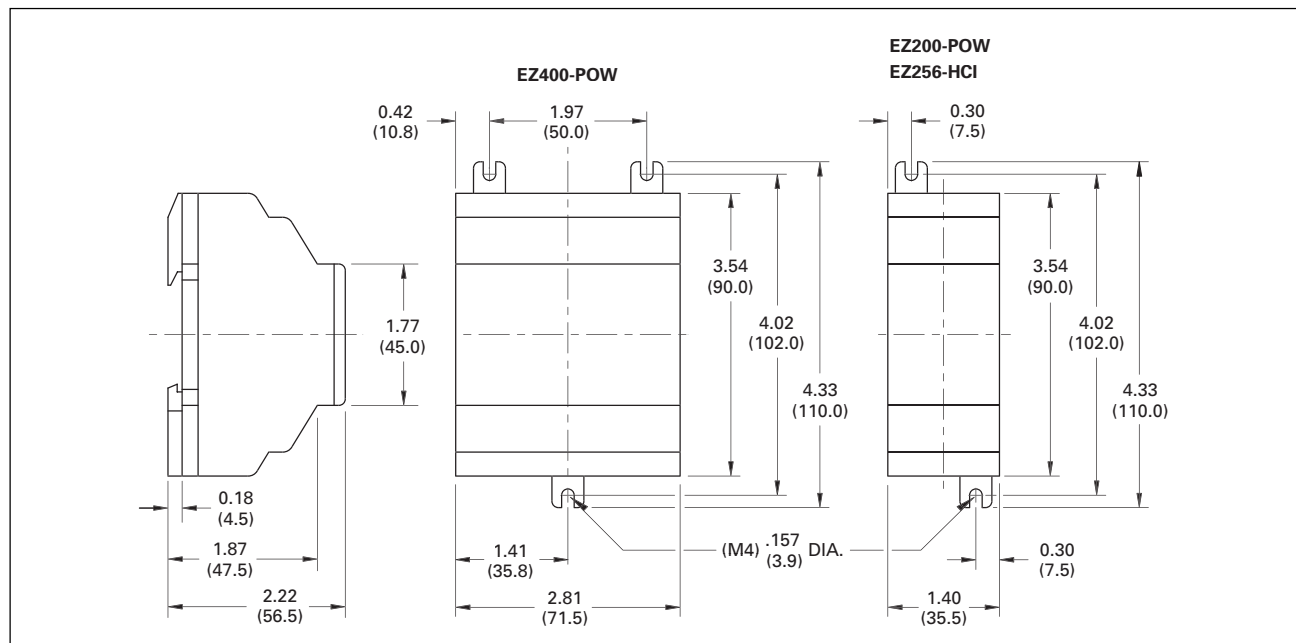
Figure 30. EZ200-POW/EZ256-HCI and EZ400-POW Series Dimensions in Inches (mm), Drawing Number MD05013004E

EZ/EZD Accessories



EZ700/500 Panel Window and Mounting Kit

Product Selection

Table 40. EZ/EZD Memory Storage Modules

Description	Catalogue Number
EZ500/700 32K Memory Storage Module	EZ-M-32K
EZ800/EZD 256K Memory Storage Module	EZ-M-256K

Table 41. EZ/EZD Programming Cables

Description	Catalogue Number
EZ500/700 to PC Cable	EZ-PC-CAB
EZ800/EZD to PC Cable	EZ800-PC-CAB

Table 42. EZ/EZD Cables and Connectors

Description	Catalogue Number
EZ500/700 to EZD-CP4 Communication Cable, 5 m	EZD-CP4-500-CAB5
EZ800 to EZD-CP8 Communication Cable, 2 m	EZD-800-CAB
EZ800 to EZD-CP8 Communication Cable, 5 m	EZD-800-CAB5
EZ800 to EZD-CP4 Communication Cable, 5 m	EZD-CP4-800-CAB5
EZ800/EZD EZ-NET Cable, 0.3 m	EZ-NT-30
EZ800/EZD EZ-NET Cable, 0.8 m	EZ-NT-80
EZ800/EZD EZ-NET Cable, 1.5 m	EZ-NT-150
EZ800/EZD Network Termination Resistor, 2/Pack	EZ-NT-R
EZ800/EZD EZ-NET Cable (cable only, no connectors, see EZ-NT-RJ45), 100 m	EZ-NT-CAB
RJ45 Network Connectors for EZ-NET Cable (EZ-NT-CAB), 10/Pack	EZ-NT-RJ45

Table 43. EZ/EZD Miscellaneous Parts

Description	Catalogue Number
EZ500 Relay Simulator	EZ412-DC-SIM-NA
EZ500 Panel Window	EZSKF-FF4
EZ700/800 Panel Window	EZSKF-FF6
EZ500/700/800 Panel Window Mounting Kit to Front Mount Units	EZSKF-HA
EZ/EZD Panel Mount Brackets, 9/Pack	EZB4-101-GF1
EZ/EZD Grounding Kit	EZB4-102-KS1
EZD Display DIN Rail Mount Kit	EZD-TS144
EZD Display Protective Membrane Cover	EZD-XM-80
EZD Display Protective Plastic Cover	EZD-XS-80
EZ/EZD 6 Channel Noise Suppression Adapter	EZ256-HCI
EZ/EZD Spare Interface Connector, Base to Expander	EZ-LINK-DS
EZSoft Configuration Software	EZSOFT
EZ Starter Kit (includes EZ512-DC-RC, EZ-PC-CAB, EZ412-DC-SIM-NA, EZSoft)	EZSTARTKIT1

Dimensions

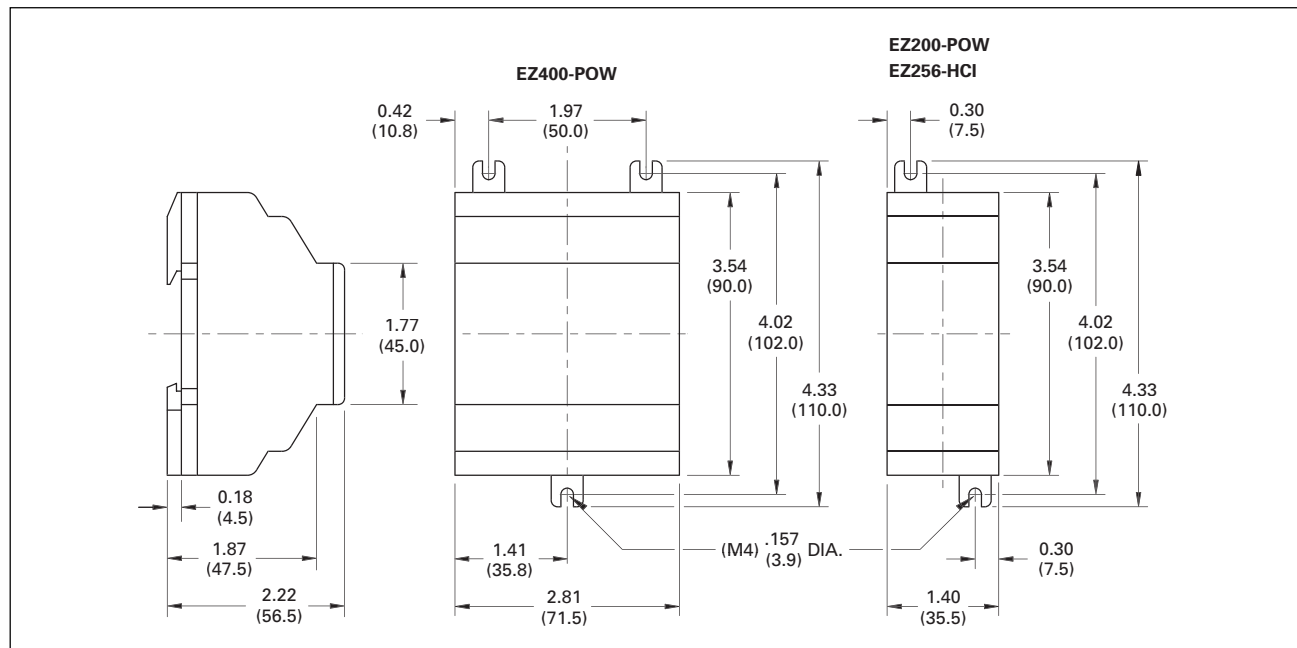

Figure 31. EZ200-POW/EZ256-HCI and EZ400-POW Series Dimensions in Inches (mm), Drawing Number MD05013004E

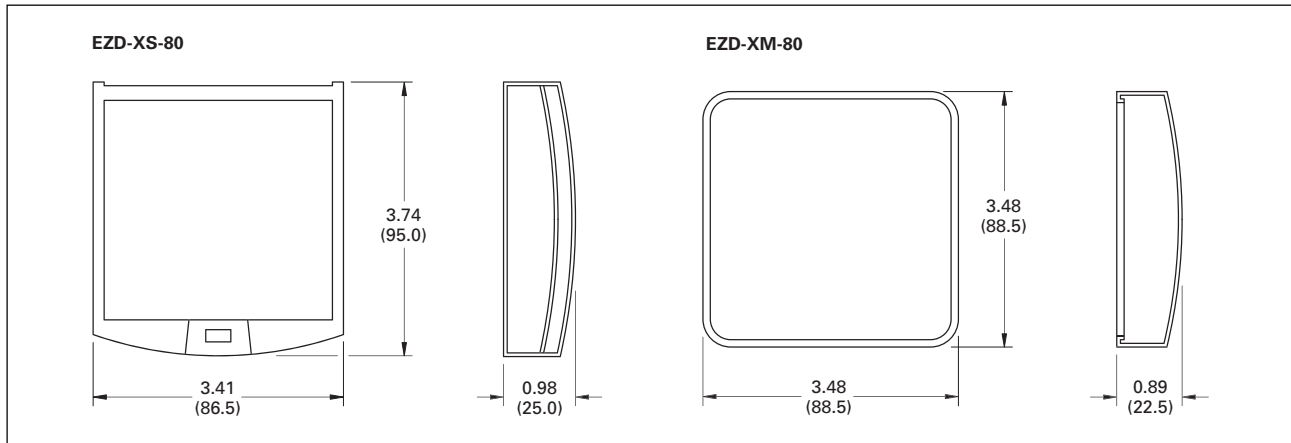

Figure 32. EZD-XS-80 and EZD-XM-80 Series Dimensions in Inches (mm), Drawing Number MD05013009E

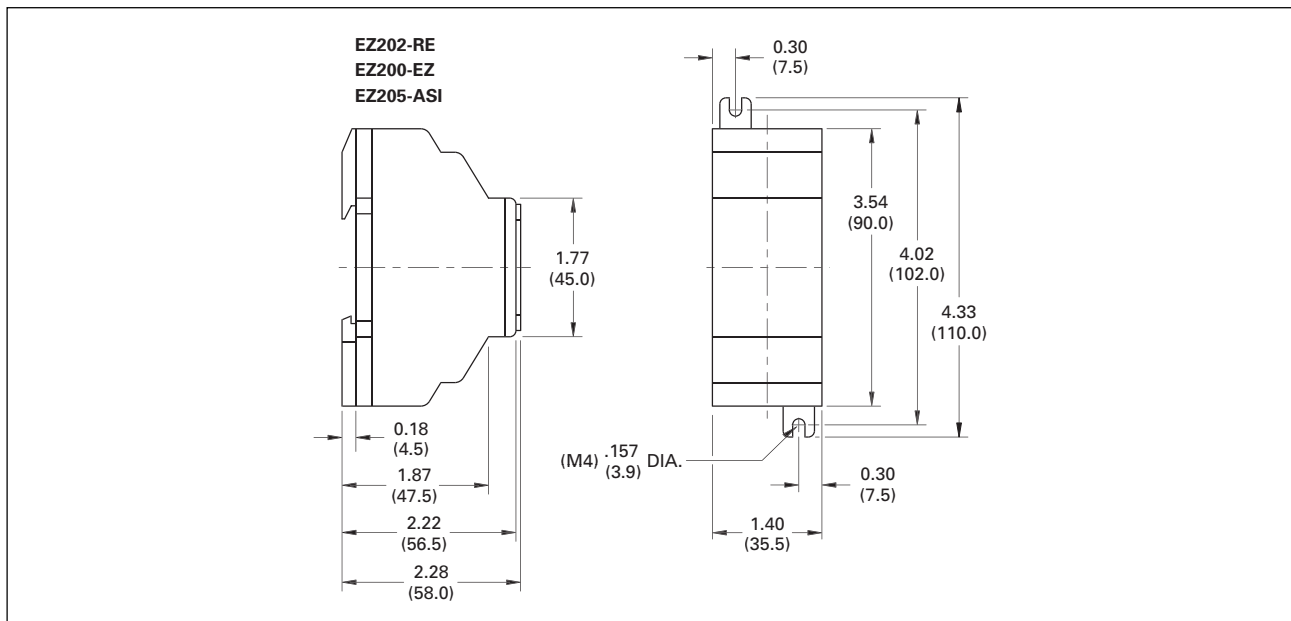

Figure 33. EZ202-RE/EZ200-EZ/EZ205-ASI Series Dimensions in Inches (mm), Drawing Number MD05013012E

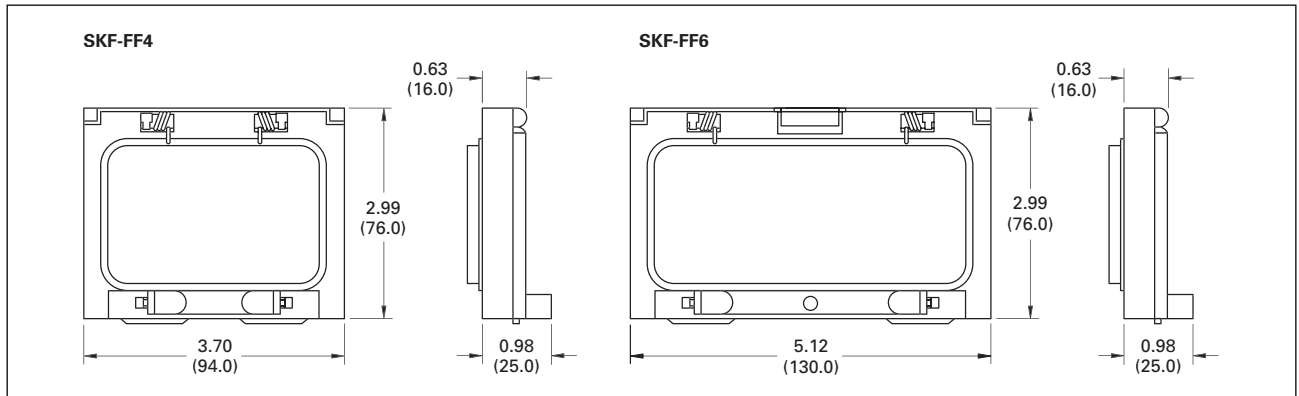

Figure 34. EZSKF-FF4 and EZSKF-FF6 Series Dimensions in Inches (mm), Drawing Number MD05013014E

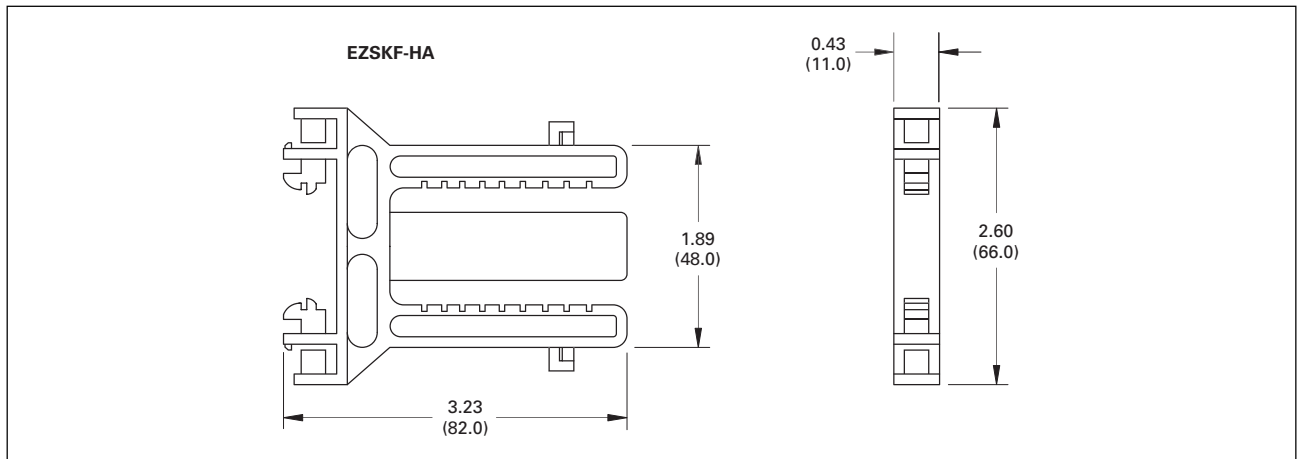

Figure 35. EZSKF-HA Series Dimensions in Inches (mm), Drawing Number MD05013015E

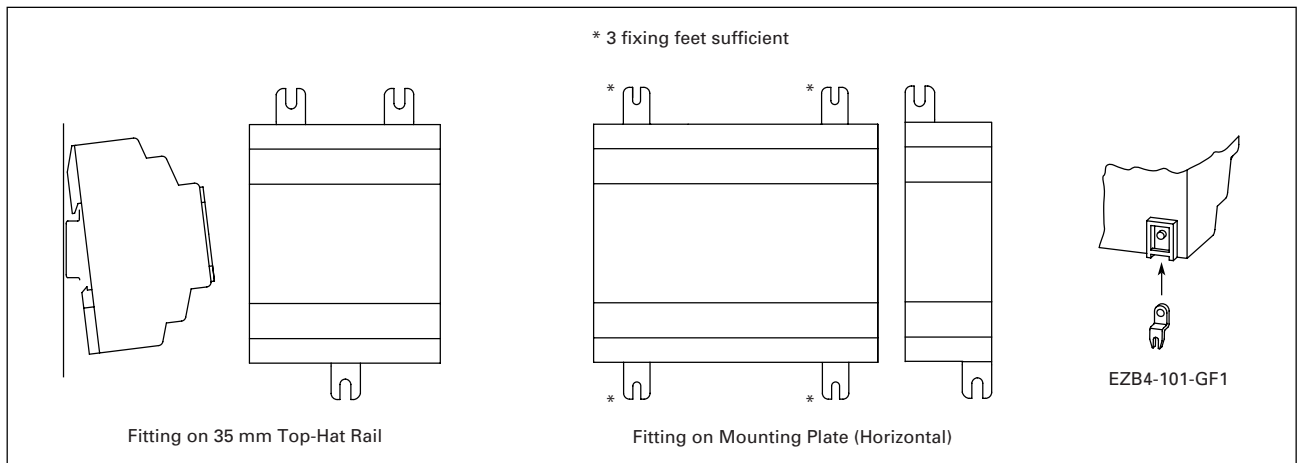

Figure 36. EZB4-101-GF1 Series

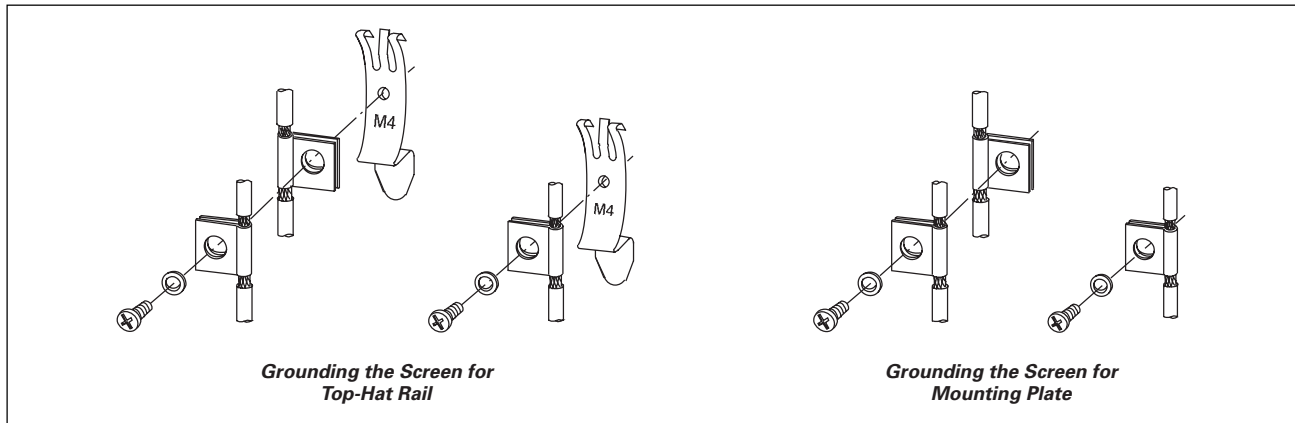

Figure 37. EZB4-102-KS1 Series

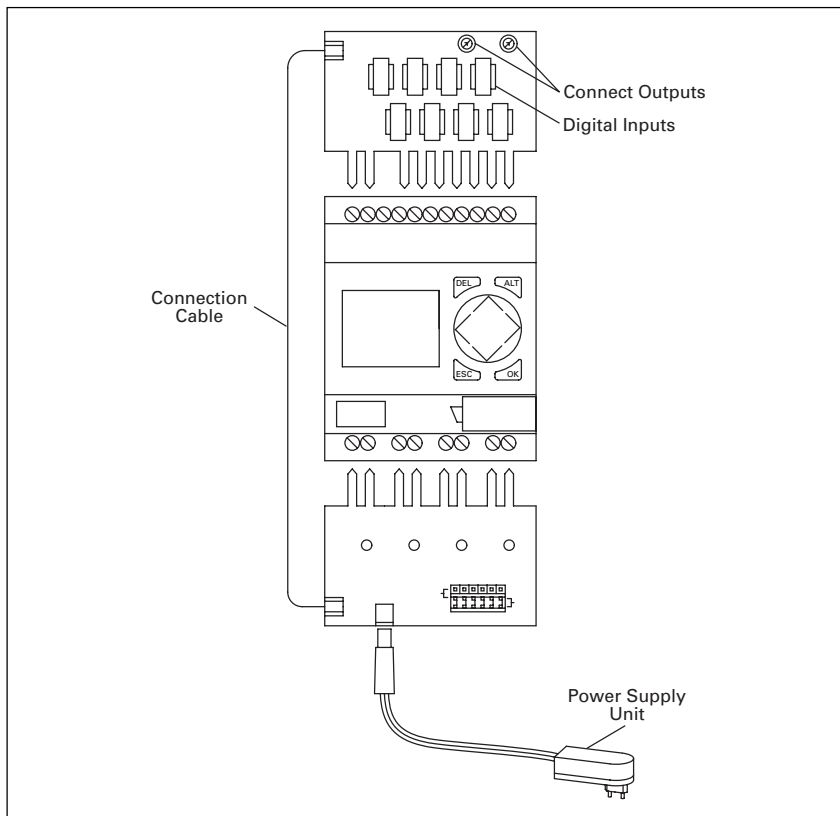

Figure 38. EZ412-DC-SIM-NA Series

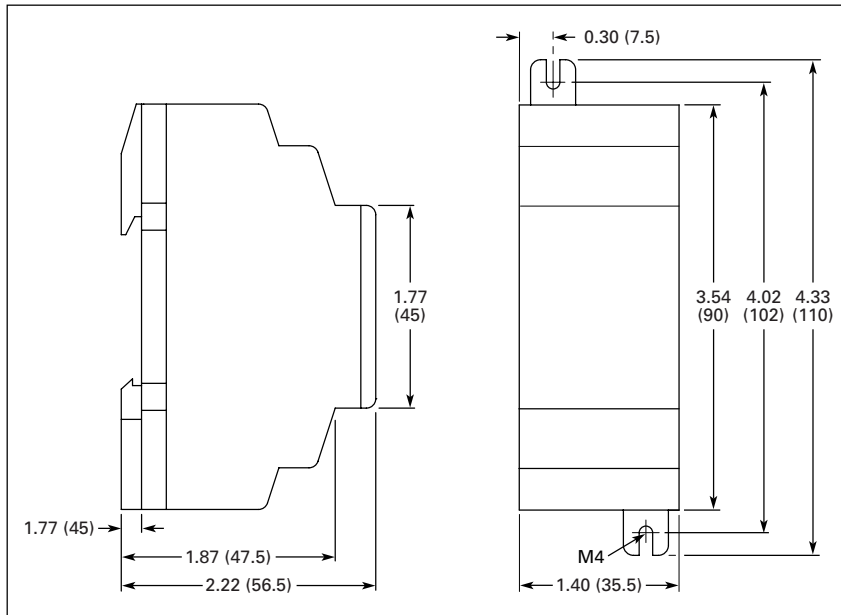

Figure 39. EZ256-HCI Dimensions in Inches (mm)

Wiring Diagram

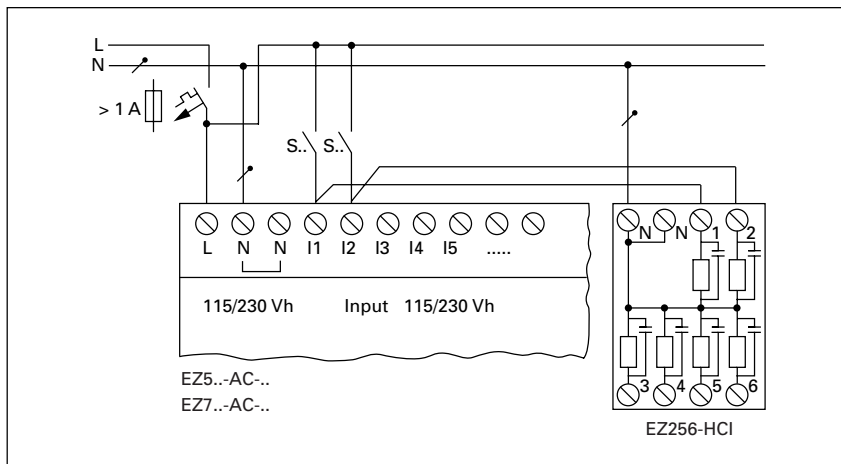
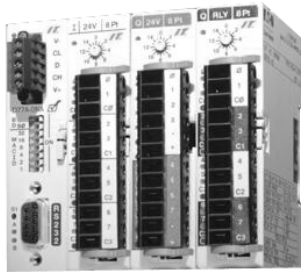

Figure 40. EZ256-HCI Wiring Diagram

Remote I/O Modules (D77A Series)



IT. I/O Products D77A-DQ8, D77A-DI8 and D77A-AQ8 with DeviceNet Adapter, D77D-DNA

Cutler-Hammer® Intelligent Technologies (*IT.*) D77A I/O Modules, which are built by Eaton's electrical business for industrial applications, are available in 8 and 16 point I/O, combination I/O and analogue I/O. These modules are capable of connecting to AC or DC voltages and also to voltage or current analogue

I/O. Input modules have two points per isolated common while the outputs are available in relay and solid-state with two points per isolated common for most output modules. When added flexibility is needed, modules that combine inputs and outputs, AC, DC and relay are available.

Application Description

Typical D77A I/O Module applications use the D77A I/O as stand-alone remote I/O and in a system where motor control and I/O are required within a single customer panel.

When used on same QCPort connection, both the I/O and the motor control can be connected to a single network adapter. The network adapter then represents the D77A I/O and motor control as remote I/O, consuming only one network address. The network then controls and monitors the QCPort devices.

Product Description

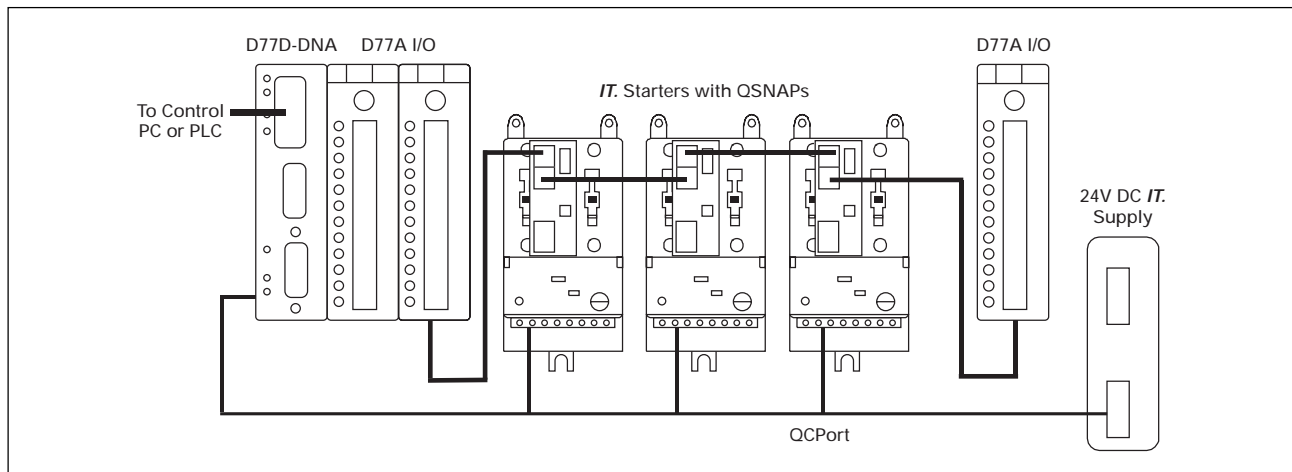

Figure 41. Application — Distributed I/O and Motor Control

February 2007

Remote I/O Modules (D77A Series)

Features, Functions and Benefits

Scalable Solutions

Since each application is different, the I/O offering has been designed to allow for maximum flexibility to tailor the I/O needs of our customer. The I/O product offering includes not only 8 and 16 point modules but also combination I/O modules. Signal types include 24V DC I/O, 120V AC I/O, solid-state outputs, relay outputs, analogue inputs and analogue outputs.

All Modules

LED Status – When the LED is illuminated, the proper ON state signal is received at the input or the output point.

Removable Lockable Terminals – To facilitate easy removal of the I/O module, the terminal block has been designed to be easily removed with the field wiring installed. A unique locking mechanism provides for easy removal of the terminal block and also positive locking of the terminal to the I/O module.

Terminal Identification – Each terminal is marked for ease of wiring and troubleshooting.

Isolation – Each I/O module is optically isolated between the field I/O and the QCPort communication.

Securing Tabs – Each I/O module has a locking mechanism so that it can be positively secured to a DIN rail.

Barrier Type Terminals – Each terminal has a barrier to minimize shorting of field wiring.

Removal/Insertion – Each I/O module supports removal and insertion under power.

Interconnection System – Each I/O module supports both a backplane style interconnect and a cable interconnect system for system communication.

Points per Common – Each I/O module supports two I/O points per isolated common except for the DC output module which is four points per isolated common.

Input Modules

Input Filter – Each input module supports a user definable input debounce. The time can be set from 1 mS to 250 mS.

Output Modules

Output Safe State – Each output module supports a user definable safe state for loss of communication. The states are hold last state, ON or OFF (default).

Configurable Power ON State – When the output module initially powers up and prior to system communication starting, the outputs can be preconfigured to go to a predefined state which can be ON or OFF (default).

Operation

When the D77A I/O Modules are properly installed and each has a properly configured Group ID, no configuration is needed for standard operation.

Discrete Input Modules

When a signal is present at the input point, the module responds using the following procedures:

1. **Optical Isolation** – Optical isolation protects the I/O circuits and communication circuits from possible damage due to transients and overvoltage.
2. **Debounce Logic/Control** – Debounce limits the effects of transients and electrical noise by requiring the input to be true for a certain period of time before the logic acknowledges a true signal. Once a true signal is achieved, the logic turns on the LED.
3. **QCPort Communication** – The logic updates the QCPort communication on a regular, scheduled basis as to the status of the input point.

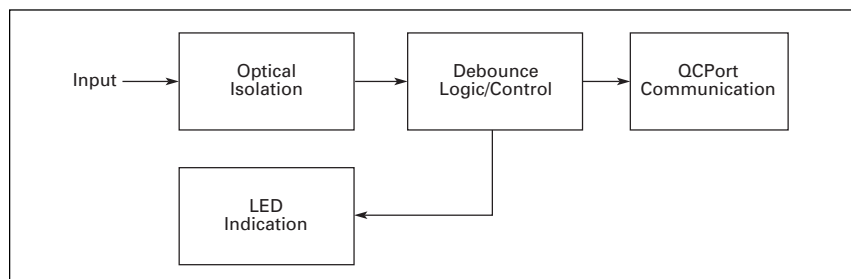

Figure 42. Input Module Operation

Discrete Output Modules

When an output is commanded to change state, the module responds using the following procedures:

1. **QCPort Communication/Logic** – QCPort communication updates the logic circuit on a regular, scheduled basis as to the status of the output points.
2. **Optical Isolation** – Optical isolation protects the I/O circuits and communication circuits from possible damage due to transients and overvoltage. Once an active signal is sent to the optical isolation, the LED is activated.
3. **Output Drivers** – The driver turns on the output point.

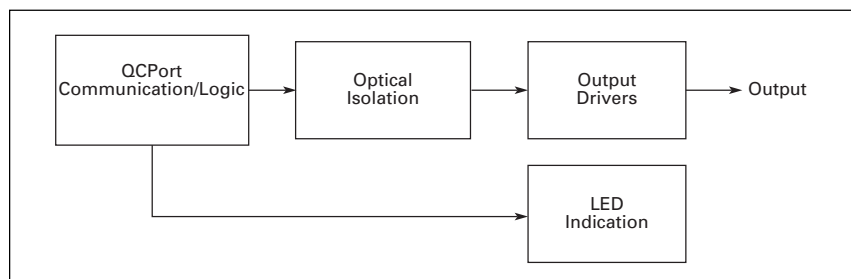

Figure 43. Output Module Operation

Remote I/O Modules (D77A Series)

Analogue Input Module

The analogue input module is single-ended uni-polar input type capable of measuring either voltage or current inputs. Each of the channels can be individually configured to be either one of the current scales or one of the voltage scales.

Analogue Output Module

The analogue output module is single-ended uni-polar output type capable of sourcing either voltage or current outputs. The analogue output module requires a 24V DC source that will provide the current or voltage source for the outputs, each of the channels can be individually configured to be either one of the current scales or one of the voltage scales.

Standards and Certifications**Approvals**

Table 44. Approvals/Certifications

Description	Specification
Electrical/EMC	
ESD Immunity (IEC 61000-4-2)	± 8 kV air, ± 4 kV contact
Radiated Immunity (IEC 61000-4-3)	10V/m 80 – 1,000 MHz, 80% amplitude modulation @ 1 kHz
Fast Transient (IEC 61000-4-4)	± 2 kV supply and control, ± 1 kV communications
Surge (IEC 61000-4-5)	± 1 kV line-to-ground, ± 2 kV line-to-line
RF Conducted (IEC 61000-4-6)	10V, .15 – 80 MHz
Magnetic Field (IEC 61000-4-8)	30A/m, 50 Hz
Voltage Dips (IEC 61000-4-11)	30% dip @ 10 mS, 60% dip @ 100 mS, >95% interrupt @ 5 mS
Other Approvals	
Ingress Protection Code	IP20
Radiated and Conducted Emissions	EN 5011 Class A
Agency Certifications	UL 508, CUL (CSA C22.2 No. 14), CE (Low Voltage Directive)

Technical Data and Specifications

Table 45. Environmental Ratings

Description	Specification
Transportation & Storage	
Temperature	-58° – 176°F (-50° – 80°C)
Humidity	5 – 95% non-condensing
Operating	
Temperature	-13° – 131°F (-25° – 55°C) Discrete I/O -32° – 131°F (0° – 55°C) Analogue I/O
Humidity	5 – 95% non-condensing
Altitude	Above 6,600 ft. (2000m) consult factory
Shock IEC 68-2-27	8G any direction for 11 mS
Vibration IEC 68-2-6	10 – 55 Hz, 3G, .7 mm maximum peak-to-peak
Pollution Degree	2
Enclosure	IP20

AC Input Modules — D77A-AI8, D77A-AI16

Table 46. Specifications

Description	Specification
Nominal Input Voltage Operating Voltage	120V AC 80 – 140V AC
Number of Inputs	8 (D77A-AI8) 16 (D77A-AI16)
Points per Common	2
OFF-State Voltage ON-State Voltage	< 30V AC > 80V AC
Nominal Input Current	15 mA
Signal Delay	1/2 Cycle
Isolation	1,500V
Module Current Draw	33 mA (D77A-AI8), 46 mA (D77A-AI6)
Terminal Screw Torque	7 – 9 in-lb

Table 47. Operating Voltage Range — AC Input Modules

OFF State		Transition Region		ON State	
0	30V AC	30V AC	80V AC	80V AC	140V AC

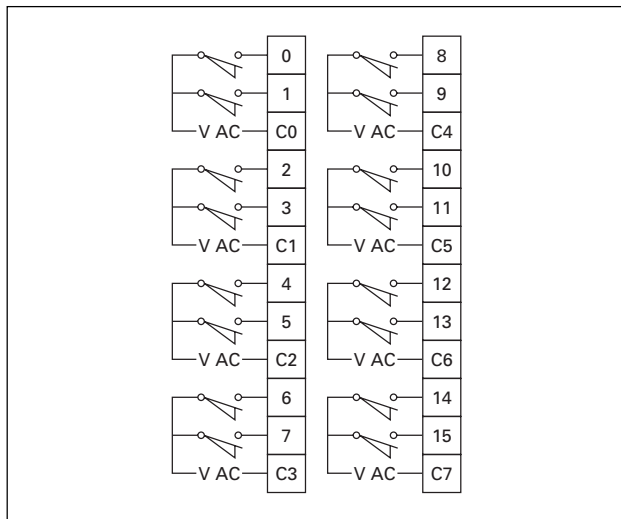

Figure 44. Wiring Diagram — AC Input Modules, D77A-AI8 & D77A-AI16

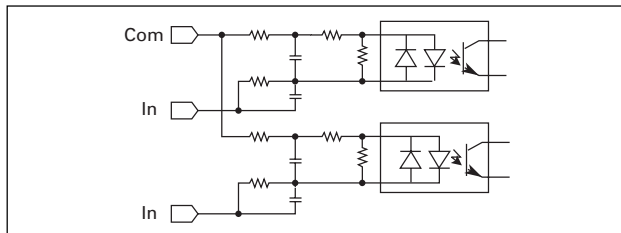

Figure 45. Circuit Diagram — AC Input Modules, D77A-AI8 & D77A-AI16

AC Output Modules — D77A-AQ8, D77A-AQ16

Table 48. Specifications

Description	Specification
Nominal Input Voltage Operating Voltage	120V AC 80 – 140V AC
Number of Outputs	8 (D77A-AQ8) 16 (D77A-AQ16)
Points per Common	2
Minimum Load Current (Resistive)	15 mA
Maximum Current/Point (Resistive)	.5A @ 30°C .1A @ 55°C
Current per Module	4A (D77A-AQ8) @ 30°C 8A (D77A-AQ16) @ 30°C
Surge Current (10 ms)	10A
OFF-State Leakage	2 mA
Signal Delay	1/2 Cycle
Module Current Draw	120 mA (D77A-AQ8) 220 mA (D77A-AQ16)
Terminal Screw Torque	7 – 9 in-lb

Table 49. Operating Voltage Range — AC Output Modules

Transition Region		ON State	
0	80V AC	80V AC	140V AC

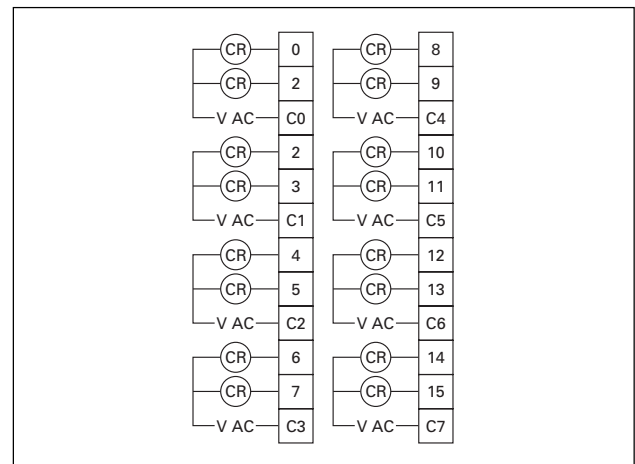

Figure 46. Wiring Diagram — AC Output Modules, D77A-AQ8 & D77A-AQ16

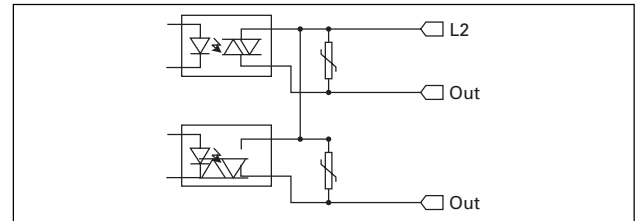

Figure 47. Circuit Diagram — AC Output Modules, D77A-AQ8 & D77A-AQ16

Remote I/O Modules (D77A Series)

DC Input Modules — D77A-DI8, D77A-DI16

Table 50. Specifications

Description	Specification
Nominal Input Voltage	24V DC
Operating Voltage	18 – 30V DC
Number of Inputs	8 (D77A-DI8) 16 (D77A-DI16)
Points per Common	2
Signal Delay	5 mS (Programmable to 250 mS)
OFF-State Voltage	< 6V DC
ON-State Voltage	> 18V DC
Nominal Input Current	5 mA
Isolation	1500V
Module Current Draw	35 mA (D77A-DI8) 49 mA (D77A-DI16)
Terminal Screw Torque	7 – 9 in-lb

Table 51. Operating Voltage Range — DC Input Modules

OFF State	Transition Region	ON State
0	6V DC	6V DC 18V DC 18V DC 30V DC

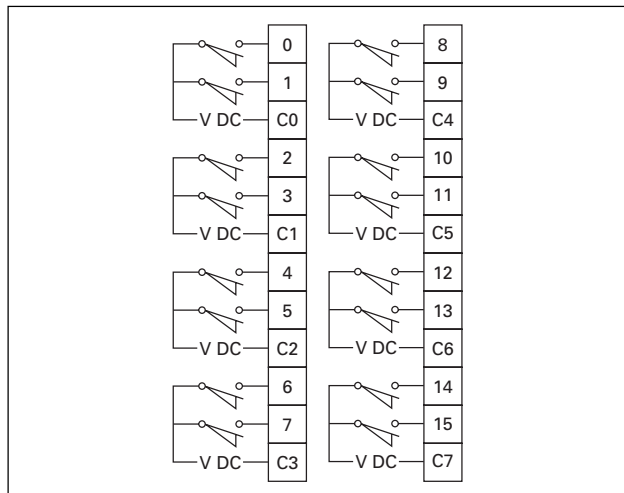

Figure 48. Wiring Diagram — DC Input Modules, D77A-DI8 & D77A-DI16

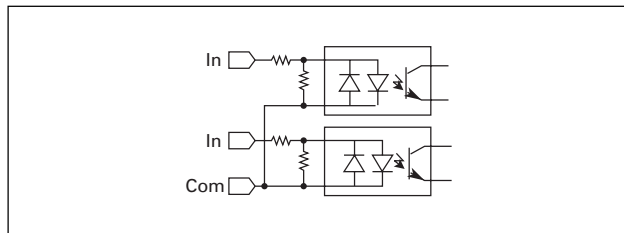

Figure 49. Circuit Diagram — DC Input Modules, D77A-DI8 & D77A-DI16

DC Output Modules — D77A-DQ8, D77A-DQ16

Table 52. Specifications

Description	Specification
Nominal Input Voltage	24V DC
Type	MOSFET sink
Operating Voltage	18 – 30V DC
Number of Outputs	8 (D77A-DQ8) 16 (D77A-DQ16)
Points per Common	4
Signal Delay	1 mS
Maximum Current/Point	.75A
Current per Module	6A (D77D-DQ8) 12A (D77D-DQ16)
Surge Current (10 ms)	4A
OFF-State Leakage	1 mA
Module Current Draw	85 mA (D77A-DQ8) 126 mA (D77A-DQ16)
Terminal Screw Torque	7 – 9 in-lb

Table 53. Operating Voltage Range — DC Output

Transition Region	ON State
0	18V DC 18V DC 30V DC

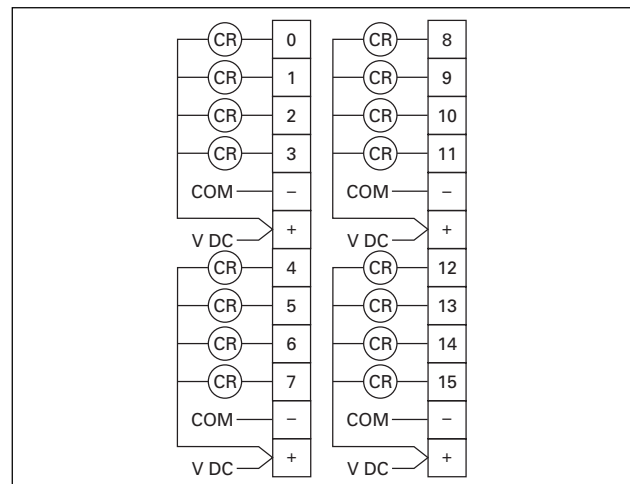

Figure 50. Wiring Diagram — DC Output Modules, D77A-DQ8 & D77A-DQ16

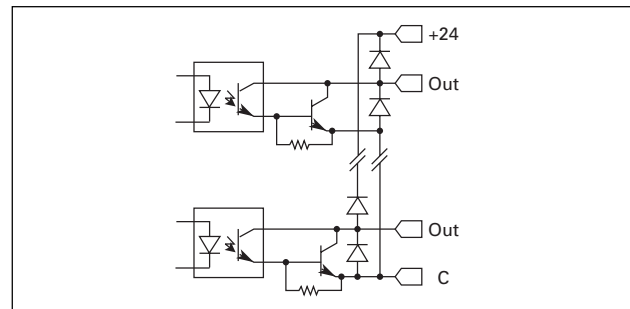

Figure 51. Circuit Diagram — DC Output Modules, D77A-DQ8 & D77A-DQ16

Relay Output Modules — D77A-RQ8, D77A-RQ16

Table 54. Relay Output Modules Specifications

Description	Specification
Nominal Voltage	120V AC 24V DC
Number of Outputs	8 (D77A-RQ8) 16 (D77A-RQ16)
Points per Common	2
Relay OFF Time	6 mS
Relay ON Time	3 mS
Max. Current per Point ¹	3A
Max. Current per Module ¹	24A (D77A-RQ8) 48A (D77A-RQ16)
Electrical Life	100,000 Cycles
Mechanical Life	1,000,000 Cycles
Module Current Draw	92 mA (D77A-RQ8) 164 mA (D77A-RQ16)

¹ Resistive current at 55°C ambient.

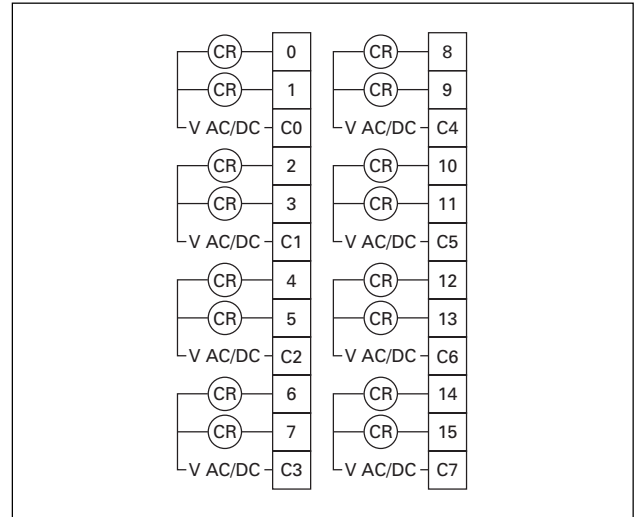

Figure 52. Wiring Diagram

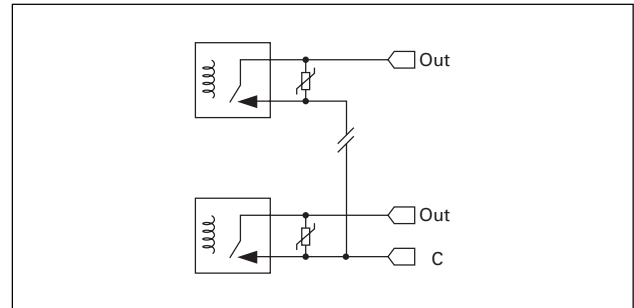

Figure 53. Circuit Diagram

Remote I/O Modules (D77A Series)

AC Input AC Output Module — D77A-A18AQ8

Table 55. Specifications

Description	Specification	
	AC Input	AC Output
Nominal Voltage	120V AC	
Operating Voltage	80 – 140V AC	
Number of Points	8	
Points per Common	2	
Signal Delay	1/2 Cycle (programmable to 250 mS)	—
OFF-State Voltage	< 30V AC	—
ON-State Voltage	> 80V AC	—
Nominal Current	15 mA	—
Signal Delay	—	1/2 Cycle
Max. Current per Point ¹	—	.5A @ 30°C .1A @ 55°C
Max. Current per Module ¹	—	4A @ 30°C .8A @ 55°C
Surge Current (10 mS)	—	10A
OFF-State Leakage	—	2 mA
Isolation	1,500V	
Module Current Draw	104 mA	

¹ Resistive current at 55°C.

Table 56. Operating Voltage Range

	OFF State	Transition Region	ON State
Input	0 30V AC		80V AC 140V AC
Output		0V AC 80V AC	80V AC 140V AC

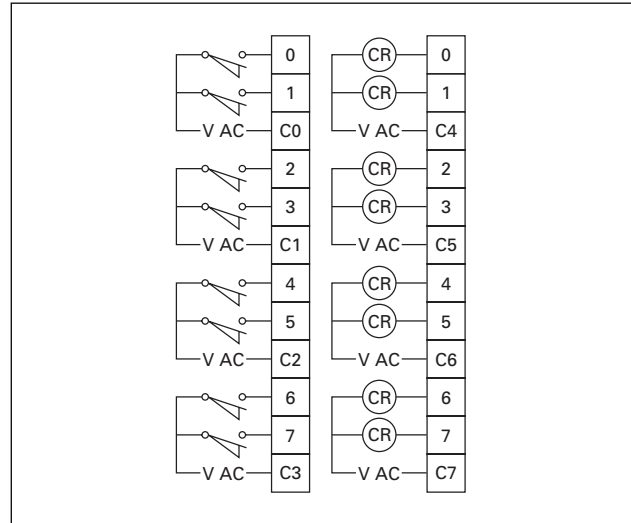

Figure 54. Wiring Diagram — AC Input AC Output

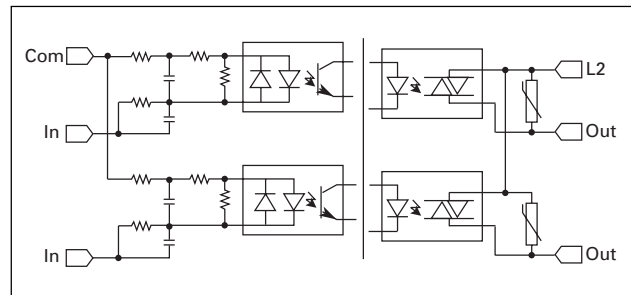

Figure 55. Circuit Diagram — AC Input AC Output

DC Input DC Output Module — D77A-DI8DQ8

Table 57. Specifications

Description	Specification	
	DC Input	DC Sink Output
Nominal Voltage	24V DC	
Operating Voltage	18 – 30V AC	
Number of Points	8	
Points per Common	2	4
Signal Delay	5 mS (programmable to 250 mS)	—
OFF-State Voltage	< 6V DC	—
ON-State Voltage	> 18V DC	—
Nominal Current	5 mA	—
Signal Delay	—	1 mS
Max. Current per Point ¹	—	.75A
Max. Current per Module ¹	—	6A
Surge Current (10 mS)	—	4A
OFF-State Leakage	—	1 mA
Isolation	1,500V	
Module Current Draw	99 mA	

¹ Resistive current at 55°C.

Table 58. Operating Voltage Range — Input

OFF State	Transition Region		ON State	
0	8V DC	8V DC	18V DC	30V DC

Table 59. Operating Voltage Range — Output

Transition Region		ON State	
0	18V DC	18V DC	30V DC

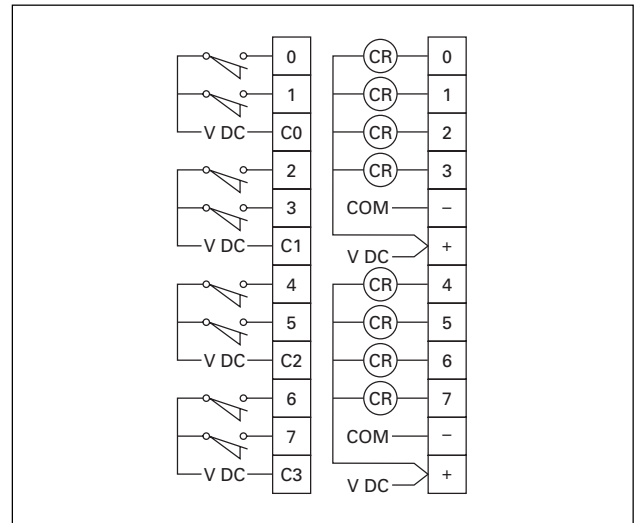

Figure 56. Wiring Diagram — DC Input DC Output

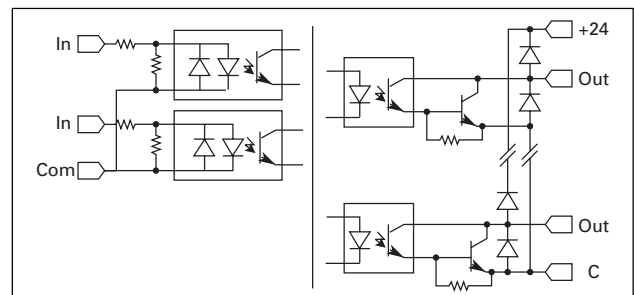

Figure 57. Circuit Diagram — DC Input DC Output

Remote I/O Modules (D77A Series)

AC Input Relay Output Module — D77A-AI8RQ8

Table 60. Specifications

Description	Specification	
	AC Input	Relay Output
Nominal Voltage	120V AC	120V AC 24V DC
Operating Voltage	80 – 140V AC	0 – 30V DC 0 – 140V AC
Number of Points	8	
Points per Common	2	
Signal Delay	1/2 Cycle (programmable to 250 mS)	—
OFF-State Voltage	< 30V AC	—
ON-State Voltage	> 80V AC	—
Nominal Current	15 mA	—
Relay OFF Time	—	6 mS
Relay ON Time	—	3 mS
Max. Current per Point ¹	—	3A
Max. Current per Module ¹	—	24A
Electrical Life	—	100,000 Cycles
Mechanical Life	—	1,000,000 Cycles
Isolation	1,500V	
Module Current Draw	104 mA	

¹ Resistive current at 55°C.

Table 61. Operating Voltage Range — Input

OFF State	Transition Region		ON State	
0	30V AC	30V AC	80V AC	80V AC 140V AC

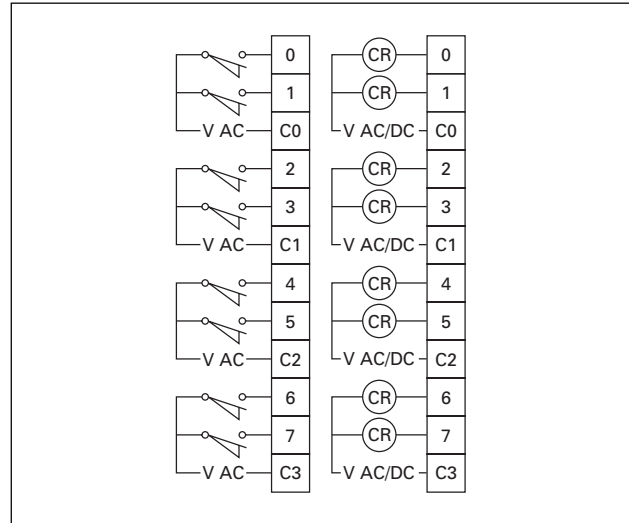

Figure 58. Wiring Diagram — AC Input Relay Output

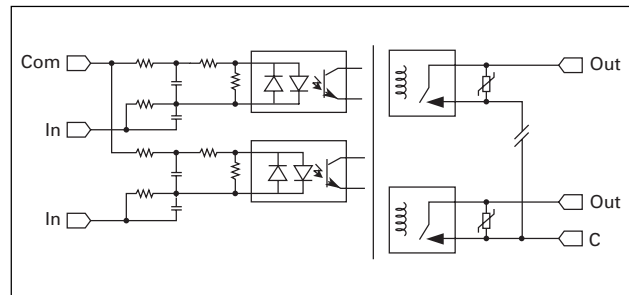

Figure 59. Circuit Diagram — AC Input Relay Output

DC Input Relay Output Module — D77A-DI8RQ8

Table 62. Specifications

Description	Specification	
	DC Input	Relay Output
Nominal Voltage	24V DC	120V AC 24V DC
Operating Voltage	18 – 30V DC	0 – 30V DC 0 – 140V AC
Number of Points	8	
Points per Common	2	
Signal Delay	5 mS (programmable to 250 mS)	—
OFF-State Voltage	< 6V DC	—
ON-State Voltage	> 18V DC	—
Nominal Current	5 mA	—
Relay OFF Time	—	6 mS
Relay ON Time	—	3 mS
Max. Current per Point ¹	—	3A
Max. Current per Module ¹	—	24A
Electrical Life	—	100,000 Cycles
Mechanical Life	—	1,000,000 Cycles
Isolation	1,500V	
Module Current Draw	106 mA	

¹ Resistive current at 55°C.

Table 63. Operating Voltage Range — Input

OFF State		Transition Region		ON State	
0	8V DC	8V DC	18V DC	18V DC	30V DC

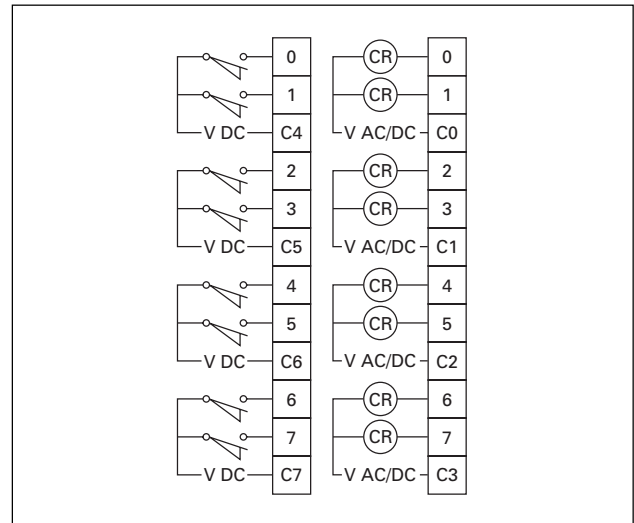

Figure 60. Wiring Diagram — DC Input Relay Output

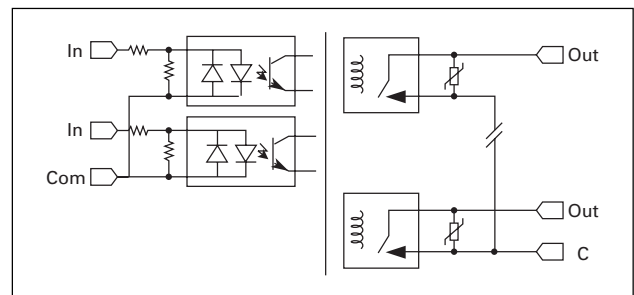

Figure 61. Circuit Diagram — DC Input Relay Output

Remote I/O Modules (D77A Series)

Analogue Input Module — D77A-NI4

Table 64. D77A-NI4 — Specifications

Description	Specification	
Voltage Input	0 – 5V DC, 1 – 5V DC, 0 – 10V DC	
Current Input	4 – 20 mA, 0 – 20 mA	
QCPort Current Draw	60 mA max.	
Input Types	Single ended, Uni-polar	
Points	4	
Resolution ¹	Filter Setting	Effective Resolution
		0 – 10V DC
		0 – 5V DC, 1 – 5V DC / 4 – 20 mA, 0 – 20 mA
	50 Hz 60 Hz 250 Hz 500 Hz	14 bit 14 bit 13 bit 13 bit
Input Full Scale	Voltage	Current
	0 – 10.5V DC, 0 – 5.25V DC	0 – 21 mA
Max Overload	30V DC / 32 mA	
Input to Bus Isolation	500V AC for 60 seconds	
Input Filter	50 Hz, 60 Hz, 250 Hz, 500 Hz	
Common Mode Rejection	> 60 dB @ 50 Hz and 60 Hz	
Normal Mode Rejection Ratio	- 50 dB @ 50 Hz and 60 Hz	
Input Impedance	Voltage	Current
	15 M ohm	250 ohm
Accuracy	Voltage	Current
	± 0.3% full scale @ 25°C ± 0.4% full scale @ 0 – 55°C	± 0.45% full scale @ 25°C ± 0.5% full scale @ 0 – 55°C
Update Rate ²	Input Filter	Update Time
	50 Hz	336 mS
	60 Hz	283 mS
	250 Hz 500 Hz	80 mS 44 mS

¹ Input filter setting affects the effective resolution of channel.

² The time to update one channel when various filters are used within one module.

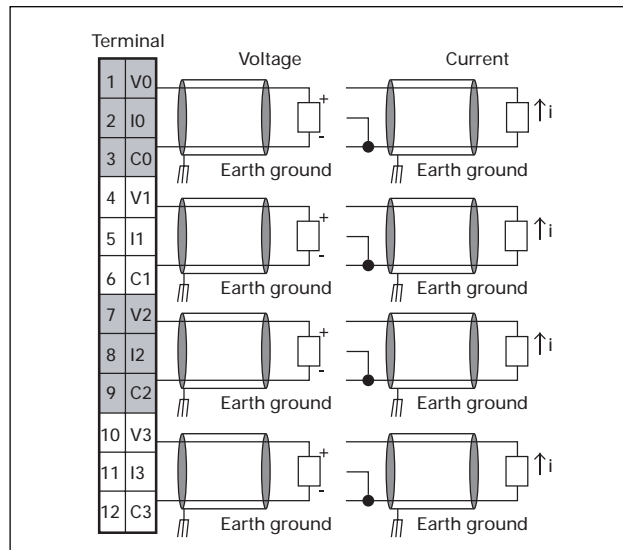

Figure 62. D77A-NI4 Wiring Diagram

Analogue Output Module — D77A-NQ2

Table 65. D77A-NQ2 — Specifications

Description	Specification	
Voltage Output	0 – 5V DC, 1 – 5V DC, 0 – 10V DC	
Current Output	4 – 20 mA, 0 – 20 mA	
CCPort Current Draw	40 mA max.	
External Power	60A max. @ 24V DC	
Output Types	Single ended, Uni-polar	
Protection	Open and Short Circuit	
Points	2	
Resolution	Range	Resolution
	4 – 20 mA, 0 – 20 mA	14 bit
	0 – 10V DC	14 bit
Output Full Scale	0 – 5V DC, 1 – 5V DC	13 bit
	Voltage	Current
	0 – 10.5V DC, 0 – 5.25V DC	0 – 21 mA
Overvoltage Protection	36V DC @ ± terminals	
Output to Bus Isolation	1500V AC for 60 seconds	
Resistive Load on Current Output	< 500 ohm	
Load Range on Voltage Output	> 1 K ohm	
Max. Inductive Load	0.1 mH	
Max. Capacitive Load	1 µF	
Output ripple (0 – 50 Hz)	± 0.1%	
Output Impedance	10 ohm	
Accuracy	Voltage	Current
	0.8% full scale @ 25°C	0.8% full scale @ 25°C
	1% full scale @ 0 – 55°C	1% full scale @ 0 – 55°C
Update Rate	350 µS	

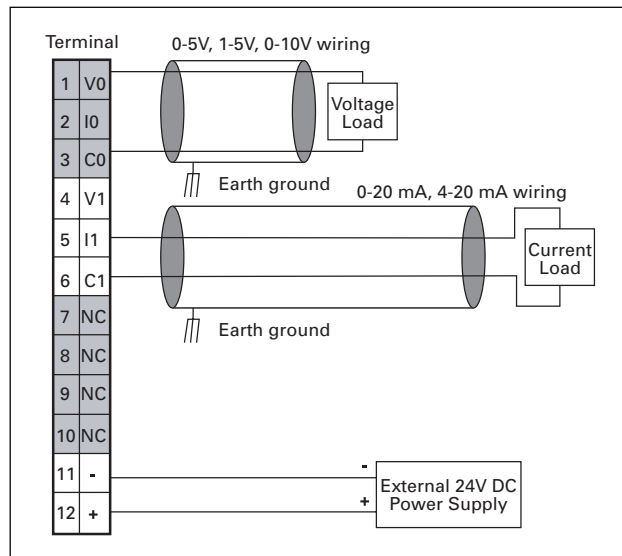

Figure 63. D77A-NQ2 Wiring Diagram

Dimensions

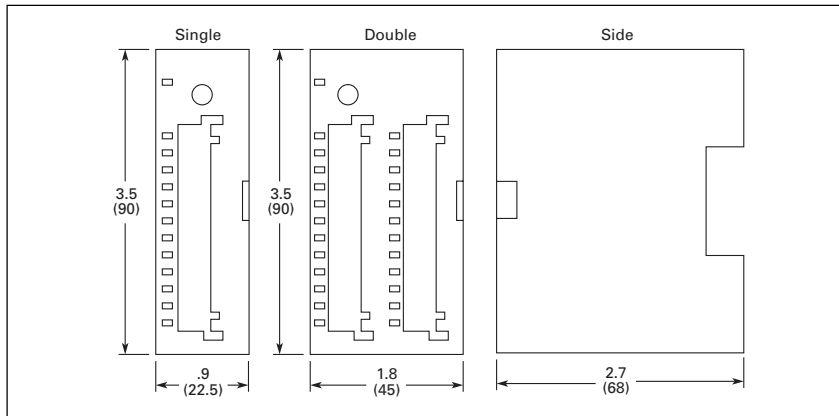

Figure 64. I/O Module — Approximate Dimensions in Inches (mm)

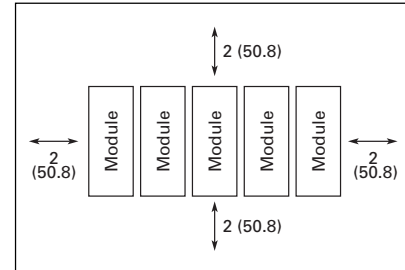

Figure 65. I/O Module Ventilation — Approximate Dimensions in Inches (mm)

Product Selection

Table 66. D77A- I/O Module Product Selection

Description	Max. Output Current per Point	Points per Common	Size	Catalogue Number
8 Point 24V DC Input	N/A	2	Single	D77A-DI8
16 Point 24V DC Input	N/A	2	Double	D77A-DI16
8 Point 24V DC Solid-State Output	.75 Amp	4	Single	D77A-QO8
16 Point 24V DC Solid-State Output	.75 Amp	4	Double	D77A-QO16
8 Point 120V AC Input	N/A	2	Single	D77A-AI8
16 Point 120V AC Input	N/A	2	Double	D77A-AI16
8 Point 120V AC Solid-State Output	.5 Amp	2	Single	D77A-AQ8
16 Point 120V AC Solid-State Output	.5 Amp	2	Double	D77A-AQ16
8 Point Relay Output (24V DC/120V AC)	3 Amp	2	Single	D77A-RQ8
16 Point Relay Output (24V DC/120V AC)	3 Amp	2	Double	D77A-RQ16
8 Point 24V DC Input / 8 Point 24V DC Output	.75 Amp	2 (in), 4 (out)	Double	D77A-DI8DO8
8 Point 24V DC Input / 8 Point Relay Output	3 Amp	2 (in), 2 (out)	Double	D77A-DI8RO8
8 Point 120V AC Input / 8 Point 120V AC Output	.5 Amp	2 (in), 2 (out)	Double	D77A-AI8AQ8
8 Point Relay Output / 8 Point 120V AC Input	3 Amp	2 (in), 2 (out)	Double	D77A-AI8RQ8
4 Point Analogue Input	N/A	4	Single	D77A-NI4
2 Point Analogue Output	N/A	2	Single	D77A-NQ2

Accessories

Table 67. I/O Module Product Accessories

Description	Catalogue Number
7-Position QCPort Backplane with DIN Rail	D77E-BP7
12-Position QCPort Backplane with DIN Rail	D77E-BP12
RJ QCPort Terminator	D77E-TERRJ
25 cm QCPort Interconnect	D77E-QPIP25
1 Meter QCPort Interconnect	D77E-QPIP100
2 Meter QCPort Interconnect	D77E-QPIP200
3 Meter QCPort Interconnect	D77E-QPIP300
QCPort Terminator and Power Tap	D77E-QPLR

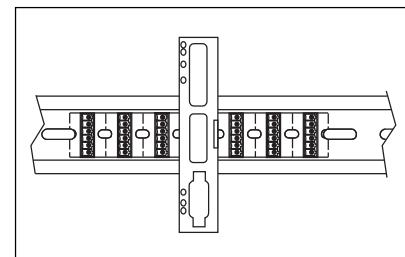

Figure 66. QC Port Backplane with DIN Rail

DeviceNet Starter Network Adapter Product (DSNAP)



Catalogue Number D77B-DSNAP-X3

Product Description

The Cutler-Hammer® DeviceNet Starter Network Adapter Product (DSNAP) from Eaton's electrical business is a front-mount device that serves as a single node on DeviceNet, providing communication capability, control and monitoring to Intelligent Technologies (IT.) Electromechanical Starters, as well as the S751 and S752 Soft Start, as listed in Tables 68 – 70.

The IT. DSNAP has an optional HANDS/OFF/AUTO (HOA) module that enables the starter to be operated in hand mode; even if the DSNAP is not powered. The HOA option is used for customers who need the extra security of manual control in conjunction with the communication capabilities of DeviceNet.

With the addition of a D64 zero sequence CT, the DSNAP can be enabled to detect ground faults for added protection.

Features

- Communication to DeviceNet consuming one DeviceNet MAC ID
- Manually set MAC ID and baud rate; configuration using a software application is not required for normal operation
- Advanced configuration using CH Studio
- Includes pre-wired starter interconnect cable and terminal adapter

Comprehensive Motor Data and Control

- RMS average current
- % of operating FLA
- % thermal memory
- Integral contact position detection
- Operating status and fault codes
- At speed (soft starters)
- START/STOP control
- RUN/FORWARD-REVERSE control
- Trip Reset

Extended Starter Capabilities

- Ground fault detection (with accessory)
- Fault log
- Overcurrent warning (adjustable)
- Undercurrent warning (adjustable)

Table 68. IEC SNAP Connectivity

IEC E101, E501		
Frame	Size	Continuous Ampacity Rating
45 mm	B	18 Amp
		25 Amp
		32 Amp
54 mm	C	40 Amp
		50 Amp
76 mm	D	65 Amp
		85 Amp
		100 Amp
105 mm	E	125 Amp
		160 Amp
		200 Amp
140 mm	F	250 Amp
		315 Amp
		420 Amp

Table 69. NEMA SNAP Connectivity

NEMA N101, N501	
Size	Continuous Ampacity Rating
00	9
0	18
1	27
2	45
3	90
4	135
5	270

Table 70. S751/S752 SNAP Connectivity

S751/S752 Soft Start	
Size	Continuous Ampacity Rating
54 mm	All Sizes

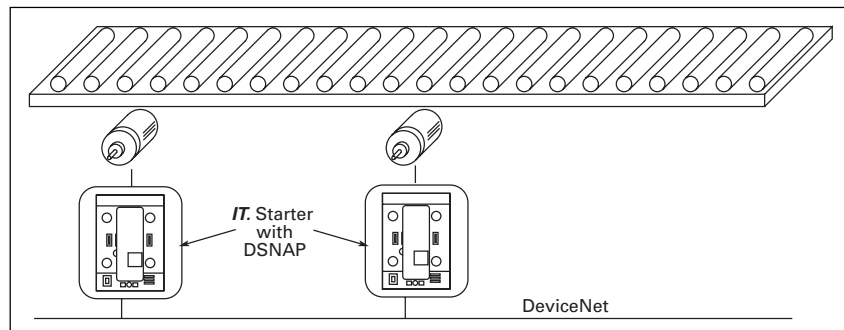

Figure 67. Typical DSNAP Application

Application Description

In a typical application, the DSNAP front mounts to an IT. starter or soft start. The DSNAP connects directly to DeviceNet, allowing for control and monitoring of the starter/soft start. A PC or PLC serves as the central control and scans the DSNAP for motor control and monitoring information. The HOA module provides for the ability to locate operators on the panel for manual operation.

Standards and Certifications

Approvals

Table 71. Approvals/Certifications

Description	Specification
Electrical/EMC	
ESD Immunity (IEC 61000-4-2)	± 8 kV air, ± 4 kV contact
Radiated Immunity (IEC 61000-4-3)	10V/m 80 – 1,000 MHz, 80% amplitude modulation @ 1 kHz
Fast Transient (IEC 61000-4-4)	± 2 kV supply and control, ± 1 kV communications
Surge (IEC 61000-4-5)	± 1 kV line-to-ground, ± 2 kV line-to-line
RF Conducted (IEC 61000-4-6)	10V, .15 – 80 MHz
Magnetic Field (IEC 61000-4-8)	30A/m, 50 Hz
Voltage Dips (IEC 61000-4-11)	30% dip @ 10 mS, 60% dip @ 100 mS, >95% interrupt @ 5 mS
Other Approvals	
Ingress Protection Code (IEC 60947-1)	IP20
Radiated and Conducted Emissions	EN 5011 Class A
Agency Certifications	UL 508, CUL (CSA C22.2 No. 14), CE (Low Voltage Directive), ODVA Conformance Tested

Technical Data and Specifications

Table 72. DeviceNet Specifications

DeviceNet Connections	Group 2 Slave Polling Explicit No UCMM
DeviceNet Baud Rate	125K, 250K, 500K

Table 73. Environmental Ratings

Description	Specifications
Transportation/Storage	
Temperature	-58° to 176°F (-50° to 80°C)
Humidity	5 – 95% non-condensing
Operating	
Temperature	-4° to 131°F (-20° to 55°C)
Humidity	5 – 95% non-condensing
Altitude	Above 2000 meters (6600 feet) consult factory
Pollution Degree	2
Power Draw	90 mA Steady State
Shock (IEC 68-2-27)	15G any direction for 11 mS
Vibration (IEC 68-2-6)	5 – 150 Hz, 5G, .7 mm max. peak-to-peak

Dimensions

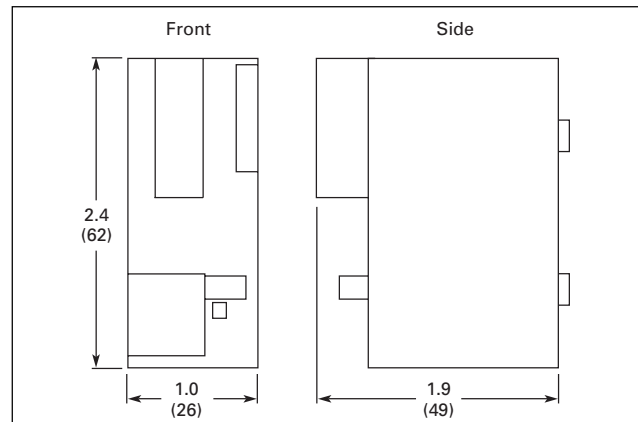

Figure 68. DSNAP Approximate Dimensions in Inches (mm)

Product Selection

Table 74. Product Selection

Description	Catalogue Number
DSNAP Kit for FVNR Starters	D77B-DSNAP-X1
DSNAP Kit for FVR Starters	D77B-DSNAP-X2
DSNAP Kit for FVNR Starters with HOA	D77B-DSNAP-X3
DSNAP Kit for FVR Starters with HOA	D77B-DSNAP-X4
DSNAP Adapter for Size 5 and Size F Frame Starters	D77B-140A
SNAP Auxiliary Connector	D77B-AC1

Note: For D64 zero sequence CTs refer to Tab 49 in Publication No. CA08102001E.

QCPort Starter Network Adapter Product (QSNAP)



Catalogue Number D77B-QSNAP-X1

Product Description

The Cutler-Hammer® QCPort Starter Network Adapter Product (QSNAP) from Eaton's electrical business is a front-mount device providing communication capability, control and monitoring to Intelligent Technologies (IT) Electromechanical Starters, as well as the S751 and S752 Soft Start, as listed in Tables 75 – 77.

The IT. QSNAP has an optional HANDS/OFF/AUTO (HOA) module that enables the starter to be operated in hand mode; even if the QSNAP is not powered. The HOA option is used for customers who need the extra security of manual control in conjunction with industrial network communication capabilities.

With the addition of a D64 zero sequence CT, the QSNAP can be enabled to detect ground faults for added protection.

Features

- QCPort connectivity connecting motor control and I/O on same network adapter
- Configuration using a software application is not required for normal operation
- Advanced configuration using CH Studio
- Includes pre-wired starter interconnect cable and terminal adapter

Comprehensive Motor Data and Control

- RMS average current
- % of operating FLA
- % thermal memory
- Integral contact position detection
- Operating status and fault codes
- At speed (soft starters)
- START/STOP control
- RUN/FORWARD-REVERSE control
- Trip Reset

Extended Starter Capabilities

- Ground fault detection (with accessory)
- Fault log
- Overcurrent warning (adjustable)
- Undercurrent warning (adjustable)
- Emergency stop detection

Table 75. IEC SNAP Connectivity

IEC E101, E501		
Frame	Size	Continuous Ampacity Rating
45 mm	B	18 Amp
		25 Amp
		32 Amp
54 mm	C	40 Amp
		50 Amp
76 mm	D	65 Amp
		85 Amp
		100 Amp
105 mm	E	125 Amp
		160 Amp
		200 Amp
140 mm	F	250 Amp
		315 Amp
		420 Amp

Table 76. NEMA SNAP Connectivity

NEMA N101, N501	
Size	Continuous Ampacity Rating
00	9
0	18
1	27
2	45
3	90
4	135
5	270

Table 77. S751/S752 SNAP Connectivity

S751/S752 Soft Start	
54 mm	All Sizes

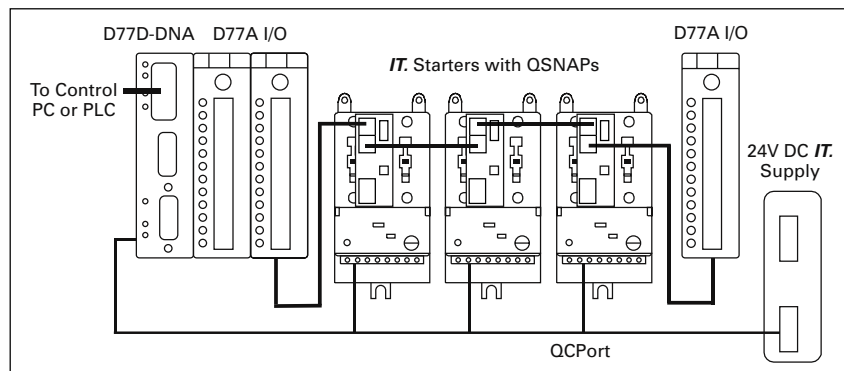

Figure 69. Typical QSNAP Application

Application Description

A typical application for the QSNAP will contain many QSNAPs and many I/O products all connected to a single network adapter. With this architecture, an entire panel can be represented by a single network adapter.

Standards and Certifications

Approvals

Table 78. Approvals/Certifications

Description	Specification
Electrical/EMC	
ESD Immunity (IEC 61000-4-2)	± 8 kV air, ± 4 kV contact
Radiated Immunity (IEC 61000-4-3)	10V/m 80 – 1,000 MHz, 80% amplitude modulation @ 1 kHz
Fast Transient (IEC 61000-4-4)	± 2 kV supply and control, ± 1 kV communications
Surge (IEC 61000-4-5)	± 1 kV line-to-ground, ± 2 kV line-to-line
RF Conducted (IEC 61000-4-6)	10V, .15 – 80 MHz
Magnetic Field (IEC 61000-4-8)	30A/m, 50 Hz
Voltage Dips (IEC 61000-4-11)	30% dip @ 10 mS, 60% dip @ 100 mS, >95% interrupt @ 5 mS
Other Approvals	
Ingress Protection Code (IEC 60947-1)	IP20
Radiated and Conducted Emissions	EN 5011 Class A
Agency Certifications	UL 508, CUL (CSA C22.2 No. 14), CE (Low Voltage Directive), ODVA Conformance Tested

Technical Data and Specifications

Table 79. Environmental Ratings

Description	Specifications
Transportation/Storage	
Temperature	-58° to 176°F (-50° to 80°C)
Humidity	5 – 95% non-condensing
Operating	
Temperature	-13° to 149°F (-25° to 65°C)
Humidity	5 – 95% non-condensing
Altitude	Above 2000 meters (6600 feet) consult factory
Power Draw	90 mA Steady State
Shock (IEC 68-2-27)	15G any direction for 11 mS
Vibration (IEC 68-2-6)	5 – 150 Hz, 5G, .7 mm max. peak-to-peak

Dimensions

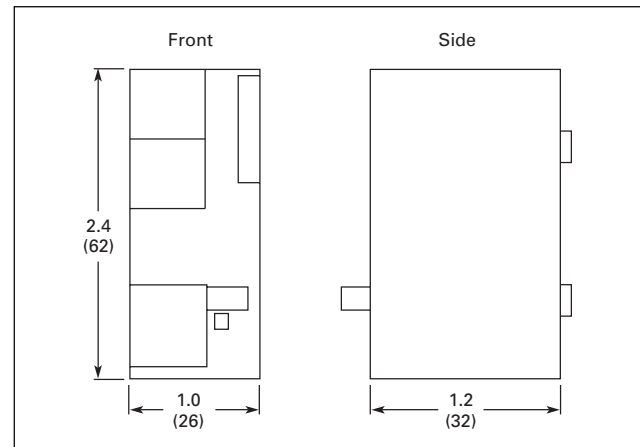

Figure 70. QSNAP Approximate Dimensions in Inches (mm)

Product Selection

Table 80. Product Selection

Description	Catalogue Number
QSNAP Kit for FVNR Starters	D77B-QSNAP-X1
QSNAP Kit for FVR Starters	D77B-QSNAP-X2
QSNAP Kit for FVNR Starters with HOA	D77B-QSNAP-X3
QSNAP Kit for FVR Starters with HOA	D77B-QSNAP-X4
QSNAP Adapter for Size 5 and Size F Frame Starters	D77B-140A
SNAP Auxiliary Connector	D77B-AC1

Note: For D64 zero sequence CTs refer to Tab 49 in Publication No. CA08102001E.

February 2007

Communication Adapters (D77D Series) — DeviceNet Adapter

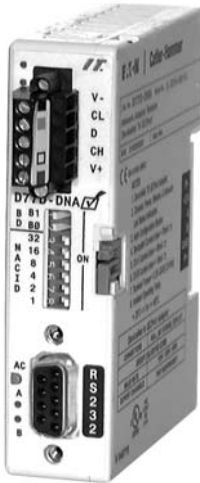

Cat. No. D77D-DNA

Product Description

The Cutler-Hammer® Intelligent Technologies (IT) DeviceNet Adapter (D77D-DNA) from Eaton's electrical business has greatly increased the functionality of IT communicating products, allowing monitoring and control for IT I/O and IT motor control devices. The adapter concentrates all data from these devices into a single DeviceNet node.

To simplify the configuration of the D77D-DNA, a simple auto-configure button press sets the system up for default operation. This automatically configures the DeviceNet I/O assemblies to the QCPort system devices. The data from these devices is assembled into a single input and output message.

Application Description

In a typical DeviceNet Adapter application, the D77D-DNA connects directly to DeviceNet, and resides in a system with IT I/O and other communicating motor controls. The data from these IT devices is assembled into a single input and output message before being presented to DeviceNet.

Features, Functions and Benefits

- Communication to DeviceNet consuming one DeviceNet MAC ID
- Provides for control of all IT communicating devices connected to the gateway
- Manually set to MAC ID and baud rate; configuration using a software application is not required for normal operation
- Single button press auto configures the gateway, setting up the system for default operation
- Advanced configuration using CH Studio
- Provides for backplane and inter-connect cable connections to QCPort
- Provides one I/O DeviceNet message representing all QCPort subscanned devices
- Two independent QCPort (communication) ports
- Powered from QCPort
- Isolated from DeviceNet
- Status LEDs for DeviceNet, QCPort and module health
- Provides for configuration of QCPort devices over DeviceNet
- Small package size
- DIN rail mountable

Standards and Certifications

Approvals

Table 81. Approvals/Certifications

Description	Specification
Electrical/EMC	
ESD Immunity (IEC 61000-4-2)	± 8 kV air, ± 4 kV contact
Radiated Immunity (IEC 61000-4-3)	10V/m 80 – 1,000 MHz, 80% amplitude modulation @ 1 kHz
Fast Transient (IEC 61000-4-4)	± 2 kV supply and control, ± 1 kV communications
Surge (IEC 61000-4-5)	± 1 kV line-to-ground, ± 2 kV line-to-line
RF Conducted (IEC 61000-4-6)	10V, .15 – 80 MHz
Magnetic Field (IEC 61000-4-8)	30A/m, 50 Hz
Other Approvals	
Ingress Protection Code	IP20
Radiated and Conducted Emissions	EN 5011 Class A
Agency Certifications	UL 508, CUL (CSA C22.2 No. 14), CE (Low Voltage Directive), ODVA Conformance Tested

Technical Data and Specifications

Table 82. DeviceNet Specifications

Description	Specification
DeviceNet Connections	Group 2, Polling, Bit Strobe, Explicit, No UCMM
Maximum DeviceNet I/O Size	128 Bytes Input 128 Bytes Output
DeviceNet Baud Rate	125K, 250K, 500K
QCPort Channels	2 Independent Channels

Table 83. Environmental Ratings

Description	Specification
-------------	---------------

Transportation/Storage

Temperature	-58° – 176°F (-50° – 80°C)
Humidity	5 – 95% non-condensing

Operating

Temperature	-13° – 131°F (-25° – 55°C)
Humidity	5 – 95% non-condensing
Altitude	Above 6,600 ft. (2,000m) consult factory
Shock (IEC 68-2-27)	15G any direction for 11 mS
Vibration (IEC 68-2-6)	5 – 150 Hz, 5G .7 mm maximum peak-to-peak
Pollution Degree	2

Dimensions

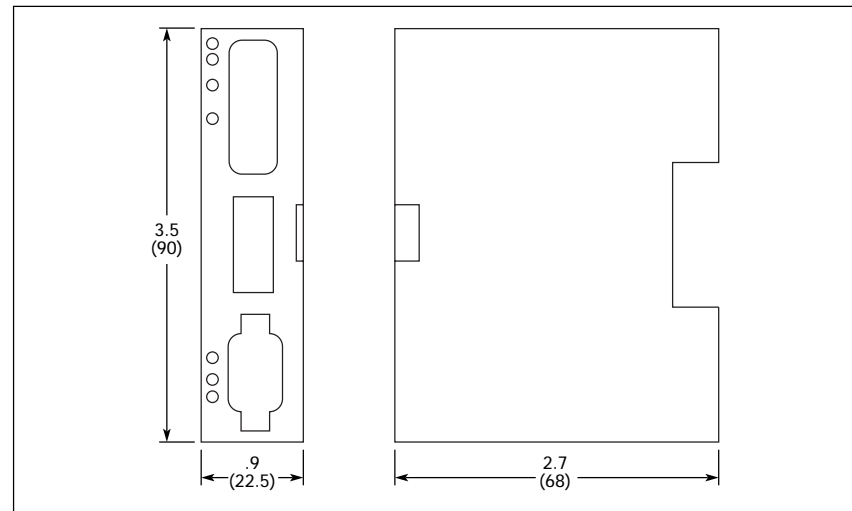

Figure 71. D77D-DNA — Approximate Dimensions in Inches (mm)

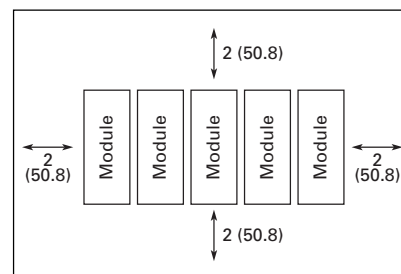

Figure 72. D77D-DNA Module Ventilation — Approximate Dimensions in Inches (mm)

Product Selection

Table 84. DeviceNet Adapter Product Selection

Description	Catalogue Number
DeviceNet Adapter	D77D-DNA



Cat. No. D77D-EMA

Product Description

The Cutler-Hammer® Intelligent Technologies (IT). Ethernet Modbus Adapter (D77D-EMA) from Eaton's electrical business has greatly increased the functionality of Cutler-Hammer IT. communicating products, allowing monitoring and control for IT. I/O and IT. motor control devices. The adapter concentrates all data from these devices into a single Modbus node.

The Modbus Adapter supports not only Modbus TCP but also Modbus serial (ASCII and RTU) as a slave device. This combination of the two physical layers provides for ultimate functionality when connecting to a Modbus system. A unique attribute of the D77D-EMA is that it supports Modbus serial Pass-Through. In this mode a customer can connect Modbus serial devices to one of the QCPort channels and monitor and control them over Modbus TCP.

To simplify the configuration of the D77D-EMA, a simple auto-configure button press sets the system up for default operation. This automatically configures the Modbus registers to the QCPort system devices.

Application Description

In a typical Modbus Adapter application, the D77D-EMA connects directly to Modbus, and resides in a system with IT. I/O and other communicating motor controls. The data from these IT. devices is assembled into input and output registers before being presented to Modbus.

Features, Functions and Benefits

- Communication to Modbus consuming one address
- Supports Boot P and static IP addressing
- 10 BaseT Connection
- RS-485 Modbus slave serial connection
- Supports Serial Modbus Pass-Through over Modbus TCP
- Provides for control of all IT. communicating devices connected to the gateway
- Manually set to address and baud rate for serial Modbus; configuration using a software application is not required for normal operation
- Single button press auto configures the gateway, setting up the system for default operation
- Advanced configuration using CH Studio
- Provides for backplane and inter-connect cable connections to QCPort
- Two independent QCPort (communication) ports
- Powered from QCPort
- Isolated from Modbus
- Status LEDs for Modbus, QCPort and module health
- Provides for configuration of QCPort devices over Modbus TCP
- Small package size
- DIN rail mountable

Standards and Certifications

Approvals

Table 85. Approvals/Certifications

Description	Specification
Electrical/EMC	
ESD Immunity (IEC 61000-4-2)	± 8 kV air, ± 4 kV contact
Radiated Immunity (IEC 61000-4-3)	10V/m 80 – 1,000 MHz, 80% amplitude modulation @ 1 kHz
Fast Transient (IEC 61000-4-4)	± 2 kV supply and control, ± 1 kV communications
Surge (IEC 61000-4-5)	± 1 kV line-to-ground, ± 2 kV line-to-line
RF Conducted (IEC 61000-4-6)	10V, .15 – 80 MHz
Magnetic Field (IEC 61000-4-8)	30A/m, 50 Hz
Other Approvals	
Ingress Protection Code	IP20
Radiated and Conducted Emissions	EN 5011 Class A
Agency Certifications	UL 508, CUL (CSA C22.2 No. 14), CE (Low Voltage Directive), Modbus Conformance Tested

Technical Data and Specifications

Table 86. Environmental Ratings

Description	Specification
Transportation/Storage	
Temperature	-58° – 176°F (-50° – 80°C)
Humidity	5 – 95% non-condensing
Operating	
Temperature	-13° – 149 °F (-25° – 65°C)
Humidity	5 – 95% non-condensing
Altitude	Above 6,600 ft. (2,000m) consult factory
Shock (IEC 68-2-27)	15G any direction for 11 mS
Vibration (IEC 68-2-6)	5 – 150 Hz, 5G .7 mm maximum peak-to-peak
Pollution Degree	2

Table 87. Modbus Specifications

Description	Specification
Connections	10 BaseT RS-485
I/O Size	1024 Registers Input 1024 Registers Output
Baud	Ethernet 10 Megabit Serial 1200 to 115.2K baud
Addressing	Ethernet – Boot P or Static IP Serial – DIP Switch 1 – 255
QCPort Channels	2 Independent Channels

Dimensions

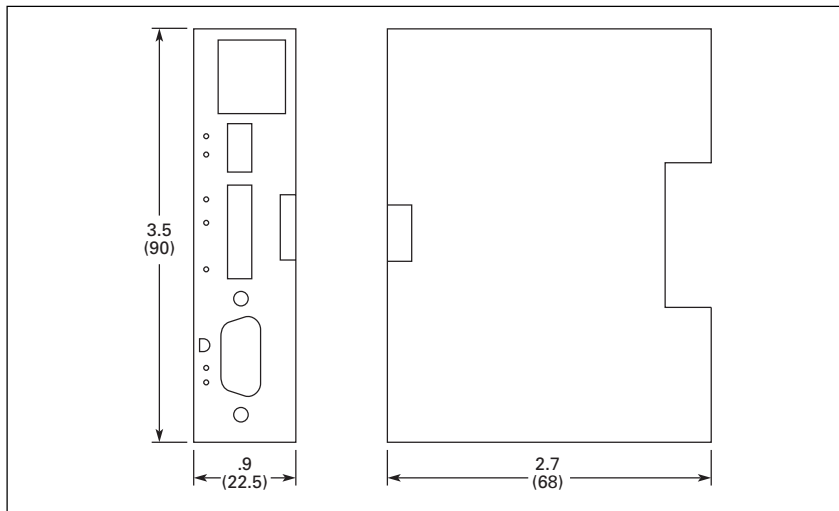

Figure 73. D77D-EMA — Approximate Dimensions in Inches (mm)

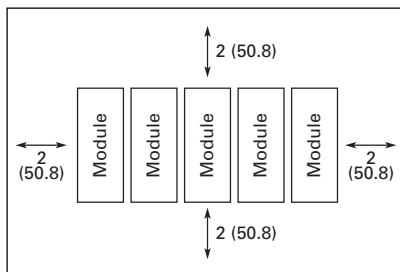

Figure 74. D77D-EMA Module Ventilation — Approximate Dimensions in Inches (mm)

Product Selection

Table 88. Modbus Adapter Product Selection

Description	Catalogue Number
Modbus Adapter	D77D-EMA



Cat. No. D77D-EIP

Product Description

The Cutler-Hammer® Intelligent Technologies (IT) EtherNet/IP (D77D-EIP) from Eaton's electrical business has greatly increased the functionality of Cutler-Hammer IT communicating products, allowing monitoring and control for IT I/O and IT motor control devices. The adapter concentrates all data from these devices into a single EtherNet/IP node.

The EtherNet/IP Adapter is a slave device on EtherNet/IP and a master on QCPort.

To simplify the configuration of the D77D-EIP, a simple auto-configure button press sets the system up for default operation. This automatically configures the EtherNet/IP assemblies to the QCPort system devices

Application Description

In a typical EtherNet/IP Adapter application, the D77D-EIP connects directly to EtherNet/IP, and resides in a system with IT I/O and other communicating motor controls. The data from these IT devices is assembled into input and output assemblies before being presented to EtherNet/IP.

Features, Functions and Benefits

- Communication to EtherNet/IP consuming one address
- Supports Boot P, DHCP and static IP addressing
- 10 BaseT Connection
- Provides for control of all IT communicating devices connected to the network adapter
- Single button press auto configures the gateway, setting up the system for default operation
- Advanced configuration using CH Studio
- Provides for backplane and inter-connect cable connections to QCPort
- Two independent QCPort (communication) ports
- Powered from QCPort
- Isolated from EtherNet/IP
- Status LEDs for EtherNet/IP, QCPort and module health
- Provides for configuration of QCPort devices over EtherNet/IP
- Small package size
- DIN rail mountable

Standards and Certifications

Approvals

Table 89. Approvals/Certifications

Description	Specification
Electrical/EMC	
ESD Immunity (IEC 61000-4-2)	± 8 kV air, ± 4 kV contact
Radiated Immunity (IEC 61000-4-3)	10V/m 80 – 1,000 MHz, 80% amplitude modulation @ 1 kHz
Fast Transient (IEC 61000-4-4)	± 2 kV supply and control, ± 1 kV communications
Surge (IEC 61000-4-5)	± 1 kV line-to-ground, ± 2 kV line-to-line
RF Conducted (IEC 61000-4-6)	10V, .15 – 80 MHz
Magnetic Field (IEC 61000-4-8)	30A/m, 50 Hz
Other Approvals	
Ingress Protection Code	IP20
Radiated and Conducted Emissions	EN 5011 Class A
Agency Certifications	UL 508, CUL (CSA C22.2 No. 14), CE (Low Voltage Directive), Modbus Conformance Tested

Technical Data and Specifications

Table 90. Environmental Ratings

Description	Specification
Transportation/Storage	
Temperature	-58° – 176°F (-50° – 80°C)
Humidity	5 – 95% non-condensing
Operating	
Temperature	-13° – 149 °F (-25° – 65°C)
Humidity	5 – 95% non-condensing
Altitude	Above 6,600 ft. (2,000m) consult factory
Shock (IEC 68-2-27)	15G any direction for 11 mS
Vibration (IEC 68-2-6)	5 – 150 Hz, 5G .7 mm maximum peak-to-peak
Pollution Degree	2

Table 91. EtherNet/IP Specifications

Description	Specification
Connections	10 BaseT
I/O Size	504 bytes Input 504 bytes Output
Baud	Ethernet 10 Megabit
Addressing	Ethernet – Boot P, Static IP or DHCP
QCPort Channels	2 Independent Channels

Dimensions

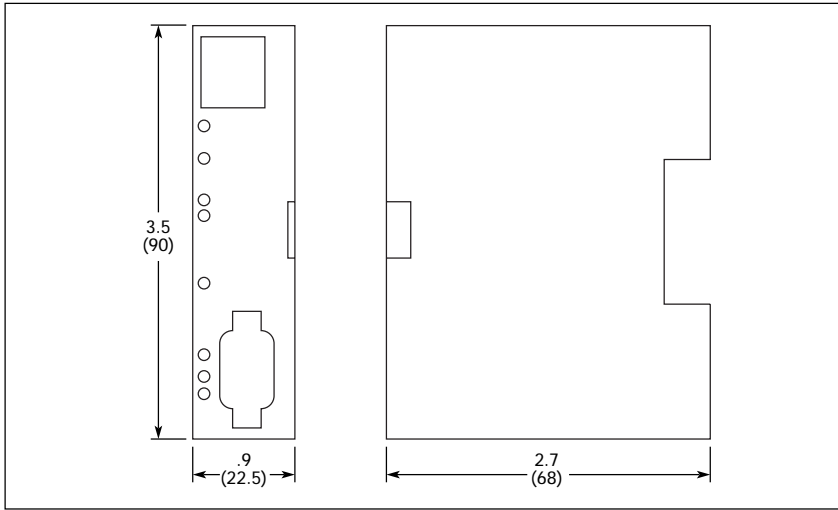

Figure 75. D77D-EIP — Approximate Dimensions in Inches (mm)

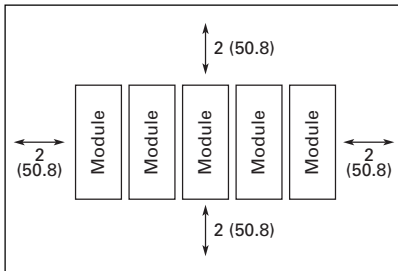
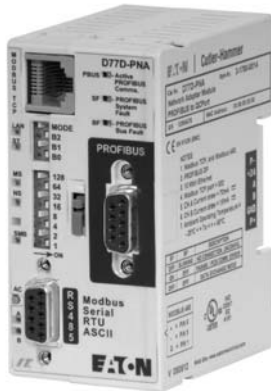

Figure 76. D77D-EIP Module Ventilation — Approximate Dimensions in Inches (mm)

Product Selection

Table 92. EtherNet/IP Adapter Product Selection

Description	Catalogue Number
Modbus Adapter	D77D-EIP



Cat. No. D77D-PNA

Product Description

The Cutler-Hammer® Intelligent Technologies (IT) PROFIBUS Adapter (D77D-PNA) from Eaton's electrical business has greatly increased the functionality of Cutler-Hammer IT communicating products, allowing monitoring and control for IT I/O and IT motor control devices. The adapter concentrates all data from these devices into a single node.

The PROFIBUS Adapter supports not only PROFIBUS but also Modbus (ASCII and RTU) as a slave device. This combination of the two physical layers provides for ultimate functionality when connecting to a control system. This unique feature of the D77D-PNA provides for deterministic control using PROFIBUS along with the flexibility to monitor and configure QCPort devices over Modbus. The Modbus connection is a read-only connection not allowing control of QCPort devices ensuring a single point of control.

To simplify the configuration of the D77D-PNA, a simple auto-configure button press sets the system up for default operation. This automatically configures the telegrams to the QCPort system devices.

Application Description

In a typical PROFIBUS Adapter application, the D77D-PNA connects directly to PROFIBUS, and resides in a system with IT I/O and other communicating motor controls. The data from these IT devices is assembled into input and output telegrams before being presented.

Features, Functions and Benefits

- Communication to PROFIBUS consuming one address
- Supports hardware addressing
- DB9 Connection
- Modbus slave connections on motherboard
- Provides for control of all IT communicating devices connected to the network adapter
- PROFIBUS supports autobaud
- Single button press auto configures the gateway, setting up the system for default operation
- Advanced configuration using CH Studio
- Provides for backplane and inter-connect cable connections to QCPort
- Two independent QCPort (communication) ports
- Powered from QCPort
- Isolated from PROFIBUS
- Status LEDs for QCPort and module health
- Provides for configuration of QCPort devices over Modbus TCP
- Small package size
- DIN rail mountable

Standards and Certifications

Approvals

Table 93. Approvals/Certifications

Description	Specification
Electrical/EMC	
ESD Immunity (IEC 61000-4-2)	± 8 kV air, ± 4 kV contact
Radiated Immunity (IEC 61000-4-3)	10V/m 80 – 1,000 MHz, 80% amplitude modulation @ 1 kHz
Fast Transient (IEC 61000-4-4)	± 2 kV supply and control, ± 1 kV communications
Surge (IEC 61000-4-5)	± 1 kV line-to-ground, ± 2 kV line-to-line
RF Conducted (IEC 61000-4-6)	10V, .15 – 80 MHz
Magnetic Field (IEC 61000-4-8)	30A/m, 50 Hz
Other Approvals	
Ingress Protection Code	IP20
Radiated and Conducted Emissions	EN 5011 Class A
Agency Certifications	UL 508, CUL (CSA C22.2 No. 14), CE (Low Voltage Directive), Modbus Conformance Tested

Technical Data and Specifications

Table 94. Environmental Ratings

Description	Specification
Transportation/Storage	
Temperature	-58° – 176°F (-50° – 80°C)
Humidity	5 – 95% non-condensing
Operating	
Temperature	-13° – 149 °F (-25° – 65°C)
Humidity	5 – 95% non-condensing
Altitude	Above 6,600 ft. (2,000m) consult factory
Shock (IEC 68-2-27)	15G any direction for 11 mS
Vibration (IEC 68-2-6)	5 – 150 Hz, 5G .7 mm maximum peak-to-peak
Pollution Degree	2

Table 95. PROFIBUS Specifications

Description	Specification
Connection	DB9
I/O Size	244 Bytes Input 176 Bytes Output
Baud	Up to 12 Megabit
Addressing	DIP Switch 1 – 255
QCPort Channels	2 Independent Channels
QCPort CHA Current Draw	170 mA
QCPort CHB Current Draw	10 mA

Dimensions

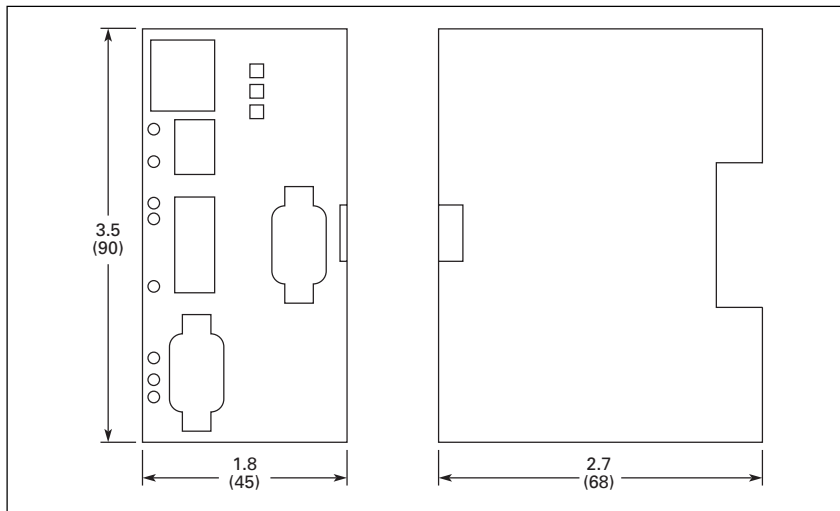

Figure 77. D77D-PNA — Approximate Dimensions in Inches (mm)

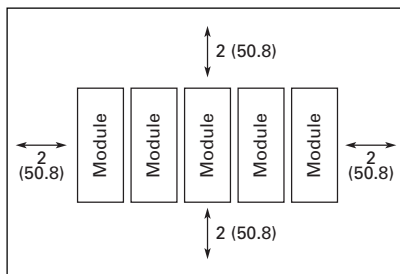

Figure 78. D77D-PNA Module Ventilation — Approximate Dimensions in Inches (mm)

Product Selection

Table 96. PROFIBUS Adapter Product Selection

Description	Catalogue Number
PROFIBUS Adapter	D77D-PNA



CH Studio

Product Description

CH Studio Component Manager Software

CH Studio from Eaton's electrical business is an integrated software development environment that supports the configuration and monitoring of control products and systems. The application simplifies the monitoring and configuration of entire networks, as well as the enhanced features of individual IT. communicating devices within those networks.

CH Studio Version 2 takes advantage of the Windows graphical interface to present a suite of tools that is easy to learn and efficient to use, while meeting the requirements for developing complex network configurations.



Screen Shot

CH Studio components include Explorer, Property, Output, Toolbox, Message Editor, Property Pages, and Device Selector windows and dialog boxes.

Configure Eaton's Cutler-Hammer Control Devices

Component Manager provides for the configuration and monitoring of the following Cutler-Hammer® products:

- IT. Motor Control Centre (MCC)
- IT. Electro-Mechanical Motor Starters connected by a Starter Network Adapter Product (SNAP) or Cover Control
- IT. S751/S752 Soft Starters connected by a SNAP, Cover Control or a Network Adapter
- IT. I/O modules
- IT. S811 Soft Starter connected by network Adapter
- IT. D77D-DNA DeviceNet network Adapter
- IT. D77D-EMA Modbus/TCP network Adapter
- IT. D77D-EIP EtherNet/IP network Adapter
- IT. D77D-PNA PROFIBUS network Adapter
- Cutler-Hammer legacy DeviceNet products

Configure Other DeviceNet Products

CH Studio provides the capacity to configure and monitor all DeviceNet products that are supported by a published EDS file, regardless of vendor.

The DeviceNet management package includes prepackaged support of over 4000 different devices, and the capability to include new EDS files, as needed.

Application Description

The CH Studio Software runs on any personal computer hosting one of the following supported Windows operating systems:

- MS Windows XP
- MS Windows 2000

A typical automation system is comprised of a programmable logic controller acting as a master, and numerous slave devices such as network adapters, motor starters, or I/O modules. The devices are networked via an industrial fieldbus such as DeviceNet or Modbus/TCP.

A personal computer hosting CH Studio may be connected to an industrial network using a supported interface card or common Ethernet port (a variety of network protocols, such as Modbus/TCP, utilize Ethernet for a physical layer). CH Studio can then be used to configure and commission the automation products and network.

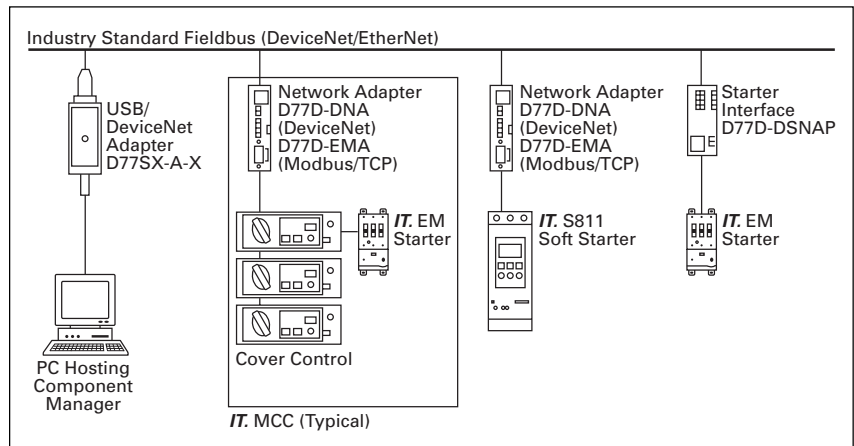

Figure 79. Network Diagram

Features, Functions and Benefits

Studio provides powerful features:

- Fast discovery of devices on DeviceNet, QCPort, and Modbus/TCP networks.
- "Snapshot" storage of an entire network worth of device parameters with just one mouse-click.
- Rapid configuration of *IT* family products via "plug-in" support components that are regularly updated via the Internet.
- Online and offline operation with flexible synchronization options.
- Custom configuration dialogs for point and click ease of configuration, support for any DeviceNet product with or without EDS files.
- Extensive report generation to assist PLC or DCS programmers.
- OPC server for industry standard communications with third party products such as HMI, data acquisition and control applications.
- Built-in 4800+ device EDS file database.
- OPC server-to-control and monitor QCPort device over OPC.
- Tag export feature to import tag data to the controller.
- Live I/O to view actual status of the QCPort I/O when online.

Technical Data and Specifications

- Processor: 230 MHz Pentium class minimum; 300+ MHz recommended.
- Memory (RAM): 64MB Minimum (may limit performance); 128MB+ recommended.
- Hard Drive Space: 120 MB - CHStudio additional 70 meg for online documentation in .PDF format.
- Super VGA 800x600 or higher resolution video adapter and monitor.
- CDROM or DVD Drive (required for installation).
- Keyboard and Microsoft mouse or compatible pointing device.
- Industrial network adapter. Studio makes use of the Ethernet port that comes as standard equipment on most PCs for industrial protocols such as MODBUS/TCP. For DeviceNet networks a USB/DeviceNet converter is available, or you may use one of the popular SS Technologies Devicenet interfaces in the 5136 series (ISA, PCI, PCMCIA supported).

USB DeviceNet Adapter

The D77SX-A-X USB converter is a cost-effective interface for DeviceNet networks. Specifically designed for use with CH Studio, the USB converter provides a high performance DeviceNet interface with Plug and Play ease of installation. The D77SX-A-X comes in kit form including USB and 6-foot DeviceNet to mini cables. Drivers for the converter are built into CH Studio.

Product Selection

The following table lists the Catalogue Numbers for available CH Studio software packages:

Table 97. CH Studio Product Selection

Description	Catalogue Number
CH Studio Component Manager V2.1	D77SC-X-D
CH Studio Component Manager V2.1 w/USB interface	D77SC-A-D
USB/DeviceNet Interface (Alone)	D77SX-A-X
CH Studio Component Manager 2.1 and OPC Server	D77SC-X-P
CH Studio Component Manager 2.1 OPC Server	D77SC-A-P

Eaton Electrical Inc.
5050 Mainway
Burlington, ON
L7L5Z1
Canada
tel: 1-800-268-3578
www.EatonElectrical.ca