

ADSP-21261/ADSP-21262/ADSP-21266

SUMMARY

High performance 32-bit/40-bit floating-point processor optimized for high performance audio processing

Code compatibility—at assembly level, uses the same instruction set as other SHARC DSPs

Processes high performance audio while enabling low system costs

Audio decoders and postprocessor algorithms support nonvolatile memory that can be configured to contain a combination of PCM 96 kHz, Dolby Digital, Dolby Digital Surround EX, DTS-ES Discrete 6.1, DTS-ES Matrix 6.1, DTS 96/24 5.1, MPEG2 AAC LC, MPEG2 BC 2ch, WMA-PRO V7.1, Dolby Pro Logic II, Dolby Pro Logic 2x, and DTS Neo:6

Various multichannel surround sound decoders are contained in ROM. For configurations of decoder algorithms, see [Table 3 on Page 4](#).

Single-instruction multiple-data (SIMD) computational architecture—two 32-bit IEEE floating-point/32-bit fixed-point/40-bit extended precision floating-point computational units, each with a multiplier, ALU, shifter, and register file

High bandwidth I/O—a parallel port, an SPI port, 6 serial ports, a Digital application interface (DAI), and JTAG

DAI incorporates two precision clock generators (PCGs), an input data port (IDP) that includes a parallel data acquisition port (PDAP), and 3 programmable timers, all under software control by the signal routing unit (SRU)

On-chip memory—up to 2M bits on-chip SRAM and a dedicated 4M bits on-chip mask-programmable ROM

The ADSP-2126x processors are available with a 150 MHz or a 200 MHz core instruction rate. For complete ordering information, see [Ordering Guide on Page 44](#).

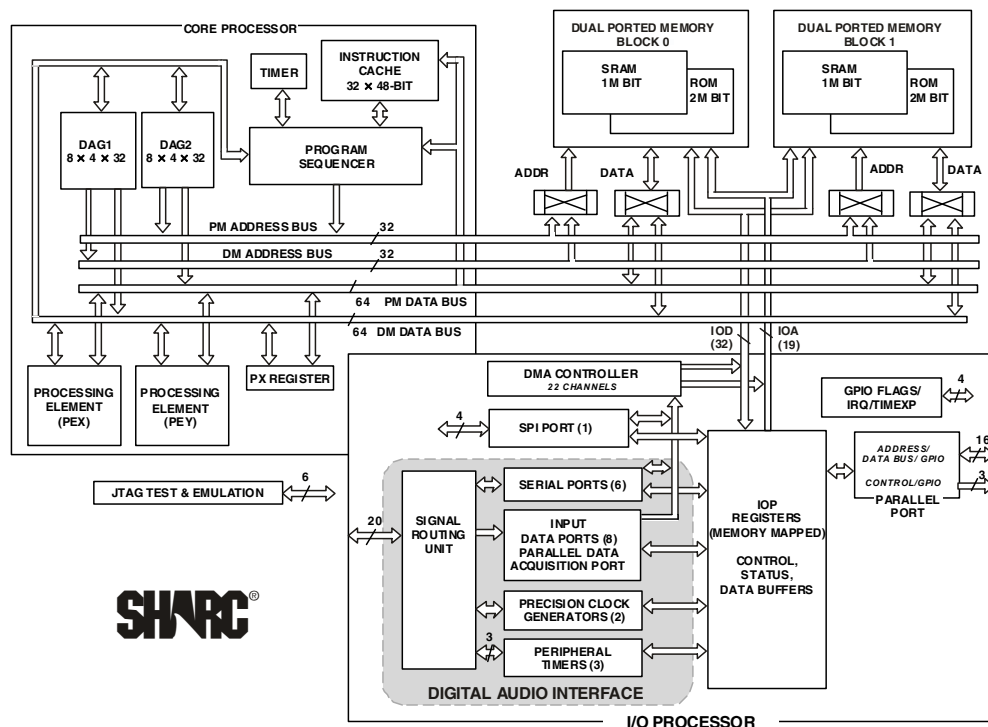

Figure 1. Functional Block Diagram

SHARC and the SHARC logo are registered trademarks of Analog Devices, Inc.

Rev. F

Information furnished by Analog Devices is believed to be accurate and reliable. However, no responsibility is assumed by Analog Devices for its use, nor for any infringements of patents or other rights of third parties that may result from its use. Specifications subject to change without notice. No license is granted by implication or otherwise under any patent or patent rights of Analog Devices. Trademarks and registered trademarks are the property of their respective owners.

One Technology Way, P.O. Box 9106, Norwood, MA 02062-9106, U.S.A.
Tel: 781.329.4700 www.analog.com
FAX: 781.461.3113 ©2009 Analog Devices, Inc. All rights reserved.

TABLE OF CONTENTS

| | | | |
|---|----|--|----|
| Summary | 1 | Electrical Characteristics | 14 |
| Table of Contents | 2 | Package Information | 15 |
| Revision History | 2 | ESD Caution | 15 |
| General Description | 3 | Maximum Power Dissipation | 15 |
| Family Core Architecture | 3 | Absolute Maximum Ratings | 15 |
| Memory and I/O Interface Features | 4 | Timing Specifications | 15 |
| Target Board JTAG Emulator Connector | 8 | Output Drive Currents | 36 |
| Development Tools | 8 | Test Conditions | 36 |
| Evaluation Kit | 9 | Capacitive Loading | 36 |
| Designing an Emulator-Compatible DSP Board (Target) | 9 | Environmental Conditions | 37 |
| Additional Information | 9 | Thermal Characteristics | 37 |
| Pin Function Descriptions | 10 | 144-Lead LQFP Pin Configurations | 38 |
| Address Data Pins as Flags | 13 | 136-Ball BGA Pin Configurations | 39 |
| Core Instruction Rate to CLKIN Ratio Modes | 13 | Outline Dimensions | 42 |
| Address Data Modes | 13 | Surface-Mount Design | 43 |
| Product Specifications | 14 | Automotive Products | 44 |
| Operating Conditions | 14 | Ordering Guide | 44 |

REVISION HISTORY

7/09—Rev. E to Rev. F

| | |
|--|----|
| Corrected all outstanding document errata. | |
| Added temperature grade. See Operating Conditions | 14 |
| Clarified VCO operations. See Voltage Controlled Oscillator | 16 |
| Corrected temperature range on industrial models. See Ordering Guide | 44 |
| Added Automotive Products | 44 |

GENERAL DESCRIPTION

The ADSP-21261/ADSP-21262/ADSP-21266 SHARC® DSPs are members of the SIMD SHARC family of DSPs featuring Analog Devices, Inc., Super Harvard Architecture. The ADSP-2126x is source code compatible with the ADSP-21160 and ADSP-21161 DSPs as well as with first generation ADSP-2106x SHARC processors in SISD (single-instruction, single-data) mode. Like other SHARC DSPs, the ADSP-2126x are 32-bit/40-bit floating-point processors optimized for high performance audio applications with dual-ported on-chip SRAM, mask-programmable ROM, multiple internal buses to eliminate I/O bottlenecks, and an innovative digital application interface.

Table 1 shows performance benchmarks for the processors running at 200 MHz. Table 2 shows the features of the individual product offerings.

Table 1. Processor Benchmarks (at 200 MHz)

| Benchmark Algorithm | Speed (at 200 MHz) |
|---|--------------------|
| 1024 Point Complex FFT (Radix 4, with reversal) | 61.3 μs |
| FIR Filter (per tap) ¹ | 3.3 ns |
| IIR Filter (per biquad) ¹ | 13.3 ns |
| Matrix Multiply (pipelined) | |
| [3×3] × [3×1] | 30 ns |
| [4×4] × [4×1] | 53.3 ns |
| Divide (y/x) | 20 ns |
| Inverse Square Root | 30 ns |

¹ Assumes two files in multichannel SIMD mode.

As shown in the functional block diagram in Figure 1 on Page 1, the ADSP-2126x uses two computational units to deliver a 5 to 10 times performance increase over previous SHARC processors on a range of DSP algorithms. Fabricated in a state-of-the-art, high speed, CMOS process, the ADSP-2126x DSPs achieve an instruction cycle time of 5 ns at 200 MHz or 6.6 ns at 150 MHz. With its SIMD computational hardware, the ADSP-2126x can perform 1200 MFLOPS running at 200 MHz, or 900 MFLOPS running at 150 MHz.

Table 2. ADSP-2126x SHARC Processor Features

| Feature | ADSP-21261 | ADSP-21262 | ADSP-21266 |
|------------------------------------|-------------------------------|-------------------------------|-------------------------------|
| RAM | 1M bit | 2M bit | 2M bit |
| ROM | 3M bit | 4M bit | 4M bit |
| Audio Decoders in ROM ¹ | No | No | Yes |
| DMA Channels | 18 | 22 | 22 |
| SPORTs | 4 | 6 | 6 |
| Package | 136-ball BGA 144-lead LQFP | 136-ball BGA 144-lead LQFP | 136-ball BGA 144-lead LQFP |

¹ For information on available audio decoding algorithms, see Table 3 on Page 4.

The ADSP-2126x continues the SHARC family's industry-leading standards of integration for DSPs, combining a high performance 32-bit DSP core with integrated, on-chip system features. These features include 2M bit dual-ported SRAM memory, 4M bit dual-ported ROM, an I/O processor that supports 22 DMA channels, six serial ports, an SPI interface, external parallel bus, and digital application interface.

The block diagram of the ADSP-2126x on Page 1 illustrates the following architectural features:

- Two processing elements, each containing an ALU, multiplier, shifter, and data register file
- Data address generators (DAG1, DAG2)
- Program sequencer with instruction cache
- PM and DM buses capable of supporting four 32-bit data transfers between memory and the core at every core processor cycle
- Three programmable interval timers with PWM generation, PWM capture/pulse width measurement, and external event counter capabilities
- On-chip dual-ported SRAM (up to 2M bit)
- On-chip dual-ported, mask-programmable ROM (up to 4M bit)
- JTAG test access port
- 8- or 16-bit parallel port that supports interfaces to off-chip memory peripherals
- DMA controller
- Six full-duplex serial ports (four on the ADSP-21261)
- SPI-compatible interface
- Digital application interface that includes two precision clock generators (PCG), an input data port (IDP), six serial ports, eight serial interfaces, a 20-bit synchronous parallel input port, 10 interrupts, six flag outputs, six flag inputs, three programmable timers, and a flexible signal routing unit (SRU)

FAMILY CORE ARCHITECTURE

The ADSP-2126x is code compatible at the assembly level with the ADSP-2136x and ADSP-2116x, and with the first generation ADSP-2106x SHARC DSPs. The ADSP-2126x shares architectural features with the ADSP-2136x and ADSP-2116x SIMD SHARC family of DSPs, as detailed in the following sections.

SIMD Computational Engine

The ADSP-2126x contain two computational processing elements that operate as a single-instruction multiple-data (SIMD) engine. The processing elements are referred to as PEX and PEY and each contains an ALU, multiplier, shifter, and register file. PEX is always active, and PEY can be enabled by setting the PEYEN mode bit in the MODE1 register. When this mode is enabled, the same instruction is executed in both processing ele-

ADSP-21261/ADSP-21262/ADSP-21266

ments, but each processing element operates on different data. This architecture is efficient at executing math intensive audio algorithms.

Entering SIMD mode also has an effect on the way data is transferred between memory and the processing elements. When in SIMD mode, twice the data bandwidth is required to sustain computational operation in the processing elements. Because of this requirement, entering SIMD mode also doubles the bandwidth between memory and the processing elements. When using the DAGs to transfer data in SIMD mode, two data values are transferred with each access of memory or the register file.

Independent, Parallel Computation Units

Within each processing element is a set of computational units. The computational units consist of an arithmetic/logic unit (ALU), multiplier, and shifter. These units perform all operations in a single cycle. The three units within each processing element are arranged in parallel, maximizing computational throughput. Single multifunction instructions execute parallel ALU and multiplier operations. In SIMD mode, the parallel ALU and multiplier operations occur in both processing elements. These computation units support IEEE 32-bit single precision floating-point, 40-bit extended precision floating-point, and 32-bit fixed-point data formats.

Data Register File

A general-purpose data register file is contained in each processing element. The register files transfer data between the computation units and the data buses, and store intermediate results. These 10-port, 32-register (16 primary, 16 secondary) register files, combined with the ADSP-2126x enhanced Harvard architecture, allow unconstrained data flow between computation units and internal memory. The registers in PEX are referred to as R0–R15 and in PEY as S0–S15.

Single-Cycle Fetch of Instruction and Four Operands

The ADSP-2126x features an enhanced Harvard architecture in which the data memory (DM) bus transfers data and the program memory (PM) bus transfers both instructions and data (see [Figure 1 on Page 1](#)). With the ADSP-2126x's separate program and data memory buses and on-chip instruction cache, the processor can simultaneously fetch four operands (two over each data bus) and one instruction (from the cache), all in a single cycle.

Instruction Cache

The ADSP-2126x includes an on-chip instruction cache that enables three-bus operation to fetch an instruction and four data values. The cache is selective—only the instructions whose fetches conflict with PM bus data accesses are cached. This cache allows full-speed execution of core, looped operations such as digital filter multiply-accumulates, and FFT butterfly processing.

Data Address Generators with Zero-Overhead Hardware Circular Buffer Support

The ADSP-2126x's two data address generators (DAGs) are used for indirect addressing and implementing circular data buffers in hardware. Circular buffers allow efficient programming of delay lines and other data structures required in digital signal processing, and are commonly used in digital filters and Fourier transforms. The two DAGs of the ADSP-2126x contain sufficient registers to allow the creation of up to 32 circular buffers (16 primary register sets, 16 secondary). The DAGs automatically handle address pointer wraparound, reduce overhead, increase performance, and simplify implementation. Circular buffers can start and end at any memory location.

Flexible Instruction Set

The 48-bit instruction word accommodates a variety of parallel operations for concise programming. For example, the ADSP-2126x can conditionally execute a multiply, an add, and a subtract in both processing elements while branching and fetching up to four 32-bit values from memory—all in a single instruction.

MEMORY AND I/O INTERFACE FEATURES

The ADSP-2126x adds the following architectural features to the SIMD SHARC family core:

Dual-Ported On-Chip Memory

The ADSP-21262 and ADSP-21266 contain two megabits of internal SRAM and four megabits of internal mask-programmable ROM. The ADSP-21261 contain one megabit of internal SRAM and three megabits of internal mask-programmable ROM. Each block can be configured for different combinations of code and data storage (see memory maps, [Table 4](#) and [Table 5](#)). Each memory block is dual-ported for single-cycle, independent accesses by the core processor and I/O processor. The dual-ported memory, in combination with three separate on-chip buses, allows two data transfers from the core and one from the I/O processor, in a single cycle.

The ADSP-2126x is available with a variety of multichannel surround sound decoders, preprogrammed in ROM memory. [Table 3](#) shows the configuration of decoder algorithms.

Table 3. Multichannel Surround Sound Decoder Algorithms in On-Chip ROM

| Algorithms | B ROM | C ROM | D ROM |
|--------------------|-------|-------|-------------------|
| PCM | Yes | Yes | Yes |
| AC-3 | Yes | Yes | Yes |
| DTS 96/24 | v2.2 | v2.3 | v2.3 |
| AAC (LC) | Yes | Yes | Coefficients only |
| WMA PRO 7.1 96 KHz | No | No | Yes |
| MPEG2 BC 2ch | Yes | Yes | No |
| Noise | Yes | Yes | Yes |
| DPL2x/EX | DPL2 | Yes | Yes |
| Neo:6/ES (v2.5046) | Yes | Yes | Yes |

The ADSP-2126x's SRAM can be configured as a maximum of 64K words of 32-bit data, 128K words of 16-bit data, 42K words of 48-bit instructions (or 40-bit data), or combinations of different word sizes up to two megabits. All of the memory can be accessed as 16-bit, 32-bit, 48-bit, or 64-bit words. A 16-bit floating-point storage format is supported that effectively doubles the amount of data that can be stored on-chip. Conversion between the 32-bit floating-point and 16-bit floating-point formats is performed in a single instruction. While each memory block can store combinations of code and data, accesses are most efficient when one block stores data using the DM bus for transfers, and the other block stores instructions and data using the PM bus for transfers.

Using the DM bus and PM buses, with one dedicated to each memory block, assures single-cycle execution with two data transfers. In this case, the instruction must be available in the cache.

DMA Controller

The ADSP-2126x's on-chip DMA controller allows zero-overhead data transfers without processor intervention. The DMA controller operates independently and invisibly to the processor core, allowing DMA operations to occur while the core is simultaneously executing its program instructions. DMA transfers can occur between the ADSP-2126x's internal memory and its serial ports, the SPI-compatible (serial peripheral interface) port, the IDP (input data port), parallel data acquisition port (PDAP), or the parallel port. Up to 22 channels of DMA are available on the ADSP-2126x—one for the SPI interface, 12 via the serial ports, eight via the input data port, and one via the processor's parallel port. Programs can be downloaded to the ADSP-2126x using DMA transfers. Other DMA features include interrupt generation upon completion of DMA transfers, and DMA chaining for automatic linked DMA transfers.

Table 4. Internal Memory Space (ADSP-21261)

| IOP Registers 0x0000 0000–0003 FFFF | | | |
|--|--|---|---|
| Long Word (64 Bits) | Extended Precision Normal or Instruction Word (48 Bits) | Normal Word (32 Bits) | Short Word (16 Bits) |
| Block 0 SRAM 0x0004 0000–0x0004 1FFF | Block 0 SRAM 0x0008 0000–0x0008 2AAA | Block 0 SRAM 0x0008 0000–0x0008 3FFF | Block 0 SRAM 0x0010 0000–0x0010 7FFF |
| Reserved 0x0004 2000–0x0005 7FFF | Reserved | Reserved 0x0008 4000–0x000A FFFF | Reserved 0x0010 8000–0x0015 FFFF |
| Block 0 ROM 0x0005 8000–0x0002 FFFF | Block 0 ROM 0x000A 0000–0x000A 7FFF | Block 0 ROM 0x000B 0000–0x000B BFFF | Block 0 ROM 0x0016 0000–0x0017 7FFF |
| Reserved 0x0005 3000–0x0005 FFFF | Reserved | Reserved 0x000B C000–0x000B FFFF | Reserved 0x0017 8FFF–0x0017 FFFF |
| Block 1 SRAM 0x0006 0000–0x0006 1FFF | Block 1 SRAM 0x000C 0000–0x000C 2AAA | Block 1 SRAM 0x000C 0000–0x000C 3FFF | Block 1 SRAM 0x0018 0000–0x0018 7FFF |
| Reserved 0x0006 2000–0x0007 7FFF | Reserved | Reserved 0x000C 4000–0x000E FFFF | Reserved 0x0018 8000–0x001D FFFF |
| Block 1 ROM 0x0007 8000–0x0007 DFFF | Block 1 ROM 0x000E 0000–0x000E 7FFF | Block 1 ROM 0x000F 0000–0x000F BFFF | Block 1 ROM 0x001E 0000–0x001F 7FFF |
| Reserved 0x0007 E000–0x0007 FFFF | Reserved | Reserved 0x000F C000–0x000F FFFF | Reserved 0x0000 |

ADSP-21261/ADSP-21262/ADSP-21266

Table 5. Internal Memory Space (ADSP-21262/ADSP-21266)

| IOP Registers 0x0000 0000–0003 FFFF | | | |
|---|---|---|---|
| Long Word (64 Bits) | Extended Precision Normal or Instruction Word (48 Bits) | Normal Word (32 Bits) | Short Word (16 Bits) |
| Block 0 SRAM 0x0004 0000–0x0004 3FFF | Block 0 SRAM 0x0008 0000–0x0008 5555 | Block 0 SRAM 0x0008 0000–0x0008 7FFF | Block 0 SRAM 0x0010 0000–0x0010 FFFF |
| Reserved 0x0004 4000–0x0005 7FFF | Reserved | Reserved 0x0008 8000–0x000A FFFF | Reserved 0x0011 0000–0x0015 FFFF |
| Block 0 ROM 0x0005 8000–0x0005 FFFF | Block 0 ROM 0x000A 0000–0x000A AAAA | Block 0 ROM 0x000B 0000–0x000B FFFF | Block 0 ROM 0x0016 0000–0x0017 FFFF |
| Block 1 SRAM 0x0006 0000–0x0006 3FFF | Block 1 SRAM 0x000C 0000–0x000C 5555 | Block 1 SRAM 0x000C 0000–0x000C 7FFF | Block 1 SRAM 0x0018 0000–0x0018 FFFF |
| Reserved 0x0006 4000–0x0007 7FFF | Reserved | Reserved 0x000C 8000–0x000E FFFF | Reserved 0x0019 0000–0x001D FFFF |
| Block 1 ROM 0x0007 8000–0x0007 FFFF | Block 1 ROM 0x000E 0000–0x000E AAAA | Block 1 ROM 0x000F 0000–0x000F FFFF | Block 1 ROM 0x001E 0000–0x001F FFFF |

Digital Application Interface (DAI)

The Digital application interface provides the ability to connect various peripherals to any of the SHARC DSP's DAI pins (DAI_P20–1).

Connections are made using the signal routing unit (SRU), shown in the block diagram on Page 1).

The SRU is a matrix routing unit (or group of multiplexers) that enables the peripherals provided by the DAI to be interconnected under software control. This allows easy use of the DAI associated peripherals for a much wider variety of applications by using a larger set of algorithms than is possible with nonconfigurable signal paths.

The DAI also includes six serial ports, two precision clock generators (PCGs), an input data port (IDP), six flag outputs and six flag inputs, and three timers. The IDP provides an additional input path to the ADSP-2126x core, configurable as either eight channels of I²S or serial data, or as seven channels plus a single 20-bit wide synchronous parallel data acquisition port. Each data channel has its own DMA channel that is independent from the ADSP-2126x's serial ports.

For complete information on using the DAI, see the *ADSP-2126x SHARC DSP Peripherals Manual*.

Serial Ports

The ADSP-2126x features six full duplex synchronous serial ports that provide an inexpensive interface to a wide variety of digital and mixed-signal peripheral devices such as the Analog Devices AD183x family of audio codecs, ADCs, and DACs. The serial ports are made up of two data lines, a clock, and frame sync. The data lines can be programmed to either transmit or receive and each data line has its own dedicated DMA channel.

Serial ports are enabled via 12 programmable and simultaneous receive or transmit pins that support up to 24 transmit or 24 receive channels of audio data when all six SPORTs are enabled, or six full duplex TDM streams of 128 channels per frame.

The serial ports operate at up to one-quarter of the DSP core clock rate, providing each with a maximum data rate of 50M bits/sec for a 200 MHz core and 37.5M bits/sec for a 150 MHz core. Serial port data can be automatically transferred to and from on-chip memory via a dedicated DMA. Each of the serial ports can work in conjunction with another serial port to provide TDM support. One SPORT provides two transmit signals while the other SPORT provides two receive signals. The frame sync and clock are shared.

Serial ports operate in four modes:

- Standard DSP serial mode
- Multichannel (TDM) mode
- I²S mode
- Left-justified sample pair mode

Left-justified sample pair mode is a mode where in each frame sync cycle, two samples of data are transmitted/received—one sample on the high segment of the frame sync, the other on the low segment of the frame sync. Programs have control over various attributes of this mode.

Each of the serial ports supports the left-justified sample-pair and I²S protocols (I²S is an industry-standard interface commonly used by audio codecs, ADCs, and DACs) with two data pins, allowing four left-justified sample-pair or I²S channels (using two stereo devices) per serial port with a maximum of up to 24 audio channels. The serial ports permit little-endian or big-endian transmission formats and word lengths selectable from 3 bits to 32 bits. For the left-justified sample pair and I²S modes, data-word lengths are selectable between 8 bits and 32 bits. Serial ports offer selectable synchronization and transmit modes as well as optional μ -law or A-law companding selection on a per channel basis. Serial port clocks and frame syncs can be internally or externally generated.

Serial Peripheral (Compatible) Interface

The serial peripheral interface is an industry-standard synchronous serial link, enabling the ADSP-2126x SPI-compatible port to communicate with other SPI-compatible devices. SPI is an interface consisting of two data pins, one device select pin, and one clock pin. It is a full-duplex synchronous serial interface, supporting both master and slave modes. The SPI port can operate in a multimaster environment by interfacing with up to four other SPI-compatible devices, either acting as a master or slave device. The ADSP-2126x SPI-compatible peripheral implementation also features programmable baud rates at up to 50 MHz for a core clock of 200 MHz and up to 37.5 MHz for a core clock of 150 MHz, clock phases, and polarities. The ADSP-2126x SPI-compatible port uses open-drain drivers to support a multimaster configuration and to avoid data contention.

Parallel Port

The parallel port provides interfaces to SRAM and peripheral devices. The multiplexed address and data pins (AD15–0) can access 8-bit devices with up to 24 bits of address, or 16-bit devices with up to 16 bits of address. In either mode, 8- or 16-bit, the maximum data transfer rate is one-third the core clock speed. As an example, a clock rate of 200 MHz is equivalent to 66M byte/sec, and a clock rate of 150 MHz is equivalent to 50M byte/sec.

DMA transfers are used to move data to and from internal memory. Access to the core is also facilitated through the parallel port register read/write functions. The \overline{RD} , \overline{WR} , and ALE (address latch enable) pins are the control pins for the parallel port.

Timers

The ADSP-2126x has a total of four timers: a core timer able to generate periodic software interrupts, and three general-purpose timers that can generate periodic interrupts and be independently set to operate in one of three modes:

- Pulse waveform generation mode
- Pulse width count/capture mode
- External event watchdog mode

The core timer can be configured to use FLAG3 as a timer expired output signal, and each general-purpose timer has one bidirectional pin and four registers that implement its mode of operation: a 6-bit configuration register, a 32-bit count register, a 32-bit period register, and a 32-bit pulse width register. A single control and status register enables or disables all three general-purpose timers independently.

ROM-Based Security

The ADSP-2126x has a ROM security feature that provides hardware support for securing user software code by preventing unauthorized reading from the internal code when enabled. When using this feature, the DSP does not boot-load any external code, executing exclusively from internal SRAM/ROM. Additionally, the DSP is not freely accessible via the JTAG port. Instead, a unique 64-bit key, which must be scanned in through

the JTAG or test access port, will be assigned to each customer. The device will ignore a wrong key. Emulation features and external boot modes are only available after the correct key is scanned.

Program Booting

The internal memory of the ADSP-2126x boots at system power-up from an 8-bit EPROM via the parallel port, an SPI master, an SPI slave, or an internal boot. Booting is determined by the boot configuration (BOOT_CFG1–0) pins.

Phase-Locked Loop

The ADSP-2126x uses an on-chip phase-locked loop (PLL) to generate the internal clock for the core. On power-up, the CLK_CFG1–0 pins are used to select ratios of 16:1, 8:1, and 3:1. After booting, numerous other ratios can be selected via software control. The ratios are made up of software configurable numerator values from 1 to 64 and software configurable divisor values of 2, 4, 8, and 16.

Power Supplies

The ADSP-2126x has separate power supply connections for the internal (V_{DDINT}), external (V_{DDEXT}), and analog (A_{VDD}/A_{VSS}) power supplies. The internal and analog supplies must meet the 1.2 V requirement. The external supply must meet the 3.3 V requirement. All external supply pins must be connected to the same power supply.

Note that the analog supply pin (A_{VDD}) powers the ADSP-2126x's internal clock generator PLL. To produce a stable clock, it is recommended that PCB designs use an external filter circuit for the A_{VDD} pin. Place the filter components as close as possible to the A_{VDD}/A_{VSS} pins. For an example circuit, see Figure 2. (A recommended ferrite chip is the muRata BLM18AG102SN1D). To reduce noise coupling, the PCB should use a parallel pair of power and ground planes for V_{DDINT} and GND. Use wide traces to connect the bypass capacitors to the analog power (A_{VDD}) and ground (A_{VSS}) pins. Note that the A_{VDD} and A_{VSS} pins specified in Figure 2 are inputs to the processor and not the analog ground plane on the board—the A_{VSS} pin should connect directly to digital ground (GND) at the chip.

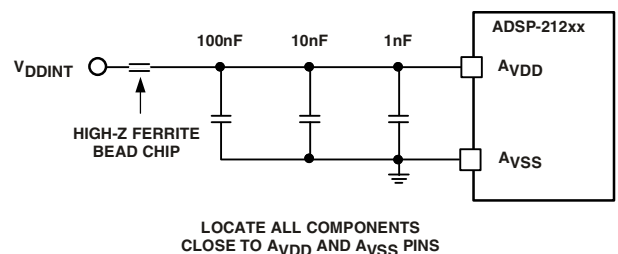

Figure 2. Analog Power Filter Circuit

ADSP-21261/ADSP-21262/ADSP-21266

TARGET BOARD JTAG EMULATOR CONNECTOR

Analog Devices DSP Tools product line of JTAG emulators uses the IEEE 1149.1 JTAG test access port of the ADSP-2126x processor to monitor and control the target board processor during emulation. Analog Devices DSP Tools product line of JTAG emulators provides emulation at full processor speed, allowing inspection and modification of memory, registers, and processor stacks. The processor's JTAG interface ensures that the emulator will not affect target system loading or timing.

For complete information on Analog Devices SHARC DSP Tools product line of JTAG emulator operation, see the appropriate emulator hardware user's guide.

DEVELOPMENT TOOLS

The ADSP-2126x is supported by a complete automotive reference design and development board as well as by a complete home audio reference design board available from Analog Devices. These boards implement complete audio decoding and postprocessing algorithms that are factory programmed into the ROM space of the ADSP-2126x. SIMD optimized libraries consume less processing resources, which results in more available processing power for custom proprietary features.

The nonvolatile memory of the ADSP-2126x can be configured to contain a combination of Dolby® Digital, Dolby Pro Logic, Dolby Digital Surround EX, Dolby Pro Logic II, Dolby Pro Logic IIX, DTS-ES, DTS® 96/24 5.1, and Neo:6™. Multiple S/PDIF and analog I/Os are provided to maximize end system flexibility.

The ADSP-2126x is also supported with a complete set of CROSSCORE®† software and hardware development tools, including Analog Devices emulators and VisualDSP++®‡ development environment. The same emulator hardware that supports other SHARC processors also fully emulates the ADSP-2126x.

The VisualDSP++ project management environment lets programmers develop and debug an application. This environment includes an easy to use assembler (which is based on an algebraic syntax), an archiver (librarian/library builder), a linker, a loader, a cycle-accurate instruction-level simulator, a C/C++ compiler, and a C/C++ runtime library that includes DSP and mathematical functions. A key point for these tools is C/C++ code efficiency. The compiler has been developed for efficient translation of C/C++ code to DSP assembly. The ADSP-2126x SHARC DSP has architectural features that improve the efficiency of compiled C/C++ code.

The VisualDSP++ debugger has a number of important features. Data visualization is enhanced by a plotting package that offers a significant level of flexibility. This graphical representation of user data enables the programmer to quickly determine the performance of an algorithm. As algorithms grow in complexity, this capability can have increasing significance on the designer's development schedule, increasing productivity. Sta-

tistical profiling enables the programmer to nonintrusively poll the processor as it is running the program. This feature, unique to VisualDSP++, enables the software developer to passively gather important code execution metrics without interrupting the real-time characteristics of the program. Essentially, the developer can identify bottlenecks in software quickly and efficiently. By using the profiler, the programmer can focus on those areas in the program that impact performance and take corrective action.

Debugging both C/C++ and assembly programs with the VisualDSP++ debugger, programmers can

- View mixed C/C++ and assembly code (interleaved source and object information)
- Insert breakpoints
- Set conditional breakpoints on registers, memory, and stacks
- Perform linear or statistical profiling of program execution
- Fill, dump, and graphically plot the contents of memory
- Perform source level debugging
- Create custom debugger windows

The VisualDSP++ IDDE lets programmers define and manage DSP software development. Its dialog boxes and property pages let programmers configure and manage all of the SHARC development tools, including the color syntax highlighting in the VisualDSP++ editor. This capability permits programmers to

- Control how the development tools process inputs and generate outputs
- Maintain a one-to-one correspondence with the tools' command line switches

The VisualDSP++ Kernel (VDK) incorporates scheduling and resource management tailored specifically to address the memory and timing constraints of DSP programming. These capabilities enable engineers to develop code more effectively, eliminating the need to start from the very beginning when developing new application code. The VDK features include threads, critical and unscheduled regions, semaphores, events, and device flags. The VDK also supports priority-based, pre-emptive, cooperative, and time-sliced scheduling approaches. In addition, the VDK was designed to be scalable. If the application does not use a specific feature, the support code for that feature is excluded from the target system.

Because the VDK is a library, a developer can decide whether to use it or not. The VDK is integrated into the VisualDSP++ development environment, but can also be used via standard command line tools. When the VDK is used, the development environment assists the developer with many error-prone tasks and assists in managing system resources, automating the generation of various VDK-based objects, and visualizing the system state when debugging an application that uses the VDK.

VisualDSP++ Component Software Engineering (VCSE) is Analog Devices' technology for creating, using, and reusing software components (independent modules of substantial functionality) to quickly and reliably assemble software applica-

† CROSSCORE is a registered trademark of Analog Devices, Inc.

‡ VisualDSP++ is a registered trademark of Analog Devices, Inc.

tions. It also is used for downloading components from the Web, dropping them into the application, and publishing component archives from within VisualDSP++. VCSE supports component implementation in C/C++ or assembly language.

Use the expert linker to visually manipulate the placement of code and data on the embedded system. View memory utilization in a color-coded graphical form, easily move code and data to different areas of the DSP or external memory with a drag of the mouse, and examine run-time stack and heap usage. The expert linker is fully compatible with existing linker definition file (LDF), allowing the developer to move between the graphical and textual environments.

In addition to the software and hardware development tools available from Analog Devices, third parties provide a wide range of tools supporting the SHARC processor family. Hardware tools include SHARC processor PC plug-in cards. Third party software tools include DSP libraries, real-time operating systems, and block diagram design tools.

EVALUATION KIT

Analog Devices offers a range of EZ-KIT Lite[†] evaluation platforms to use as a cost-effective method to learn more about developing or prototyping applications with Analog Devices processors, platforms, and software tools. Each EZ-KIT Lite includes an evaluation board along with an evaluation suite of the VisualDSP++ development and debugging environment with the C/C++ compiler, assembler, and linker. Also included are sample application programs, power supply, and a USB cable. All evaluation versions of the software tools are limited for use only with the EZ-KIT Lite product.

The USB controller on the EZ-KIT Lite board connects the board to the USB port of the user's PC, enabling the VisualDSP++ evaluation suite to emulate the on-board processor in-circuit. This permits the customer to download, execute, and debug programs for the EZ-KIT Lite system. It also allows in-circuit programming of the on-board flash device to store user-specific boot code, enabling the board to run as a stand-alone unit, without being connected to the PC.

With a full version of VisualDSP++ installed (sold separately), engineers can develop software for the EZ-KIT Lite or any custom-defined system. Connecting one of Analog Devices JTAG emulators to the EZ-KIT Lite board enables high speed, nonintrusive emulation.

DESIGNING AN EMULATOR-COMPATIBLE DSP BOARD (TARGET)

The Analog Devices family of emulators are tools that every DSP developer needs to test and debug hardware and software systems. Analog Devices has supplied an IEEE 1149.1 JTAG test access port (TAP) on each JTAG DSP. Nonintrusive in-circuit emulation is assured by the use of the processor's JTAG interface—the emulator does not affect target system loading or timing. The emulator uses the TAP to access the internal fea-

tures of the DSP, allowing the developer to load code, set breakpoints, observe variables, observe memory, and examine registers. The DSP must be halted to send data and commands, but once an operation has been completed by the emulator, the DSP system is set running at full speed with no impact on system timing.

To use these emulators, the target board must include a header that connects the DSP's JTAG port to the emulator.

For details on target board design issues including mechanical layout, single processor connections, multiprocessor scan chains, signal buffering, signal termination, and emulator pod logic, see the *EE-68: Analog Devices JTAG Emulation Technical Reference* on the Analog Devices website (www.analog.com)—use site search on “EE-68.” This document is updated regularly to keep pace with improvements to emulator support.

ADDITIONAL INFORMATION

This data sheet provides a general overview of the ADSP-2126x architecture and functionality. For detailed information on the ADSP-2126x family core architecture and instruction set, refer to the *ADSP-2126x SHARC DSP Core Manual* and the *ADSP-21160 SHARC DSP Instruction Set Reference*.

[†] EZ-KIT Lite is a registered trademark of Analog Devices, Inc.

ADSP-21261/ADSP-21262/ADSP-21266

PIN FUNCTION DESCRIPTIONS

The ADSP-2126x pin definitions are listed below. Inputs identified as synchronous (S) must meet timing requirements with respect to CLKIN (or with respect to TCK for TMS, TDI). Inputs identified as asynchronous (A) can be asserted asynchronously to CLKIN (or to TCK for TRST). Tie or pull unused inputs to V_{DDEXT} or GND, except for the following:

DAI_Px, SPICLK, MISO, MOSI, \overline{EMU} , TMS, \overline{TRST} , TDI and AD15–0 (NOTE: These pins have internal pull-up resistors.)

The following symbols appear in the Type column of [Table 6](#): A = asynchronous, G = ground, I = input, O = output, P = power supply, S = synchronous, (A/D) = active drive, (O/D) = open-drain, and T = three-state.

Table 6. Pin Descriptions

| Pin | Type | State During and After Reset | Function |
|-----------------|-------|--|--|
| AD15–0 | I/O/T | Rev. 0.1 silicon—AD15–0 pins are driven low both during and after reset. Rev. 0.2 silicon—AD15–0 pins are three-stated and pulled high both during and after reset. | Parallel Port Address/Data. The parallel port and its corresponding DMA unit output addresses and data for peripherals on these multiplexed pins. The multiplex state is determined by the ALE pin. The parallel port can operate in either 8-bit or 16-bit mode. Each AD pin has a 22.5 k Ω internal pull-up resistor. See Address Data Modes on Page 13 for details of the AD pin operation. For 8-bit mode: ALE is automatically asserted whenever a change occurs in the upper 16 external address bits, A23–8; ALE is used in conjunction with an external latch to retain the values of the A23–8. For 16-bit mode: ALE is automatically asserted whenever a change occurs in the address bits, A15–0; ALE is used in conjunction with an external latch to retain the values of the A15–0. To use these pins as flags (FLAG15–0), set (= 1) Bit 20 of the SYSCTL register and disable the parallel port. See Table 7 on Page 13 for a list of how the AD15–0 pins map to the flag pins. When configured in the IDP_PDAP_CTL register, the IDP Channel 0 can use these pins for parallel input data. |
| \overline{RD} | O | Output only, driven high ¹ | Parallel Port Read Enable. \overline{RD} is asserted low whenever the DSP reads 8-bit or 16-bit data from an external memory device. When AD15–0 are flags, this pin remains deasserted. |
| \overline{WR} | O | Output only, driven high ¹ | Parallel Port Write Enable. \overline{WR} is asserted low whenever the DSP writes 8-bit or 16-bit data to an external memory device. When AD15–0 are flags, this pin remains deasserted. |
| ALE | O | Output only, driven low ¹ | Parallel Port Address Latch Enable. ALE is asserted whenever the DSP drives a new address on the parallel port address pin. On reset, ALE is active high. However, it can be reconfigured using software to be active low. When AD15–0 are flags, this pin remains deasserted. |
| FLAG3–0 | I/O/A | Three-state | Flag Pins. Each FLAG pin is configured via control bits as either an input or output. As an input, it can be tested as a condition. As an output, it can be used to signal external peripherals. These pins can be used as an SPI interface slave select output during SPI mastering. These pins are also multiplexed with the \overline{IRQx} and the TIMEXP signals. In SPI master boot mode, FLAG0 is the slave select pin that must be connected to an SPI EPROM. FLAG0 is configured as a slave select during SPI master boot. When Bit 16 is set (= 1) in the SYSCTL register, FLAG0 is configured as $\overline{IRQ0}$. When Bit 17 is set (= 1) in the SYSCTL register, FLAG1 is configured as $\overline{IRQ1}$. When Bit 18 is set (= 1) in the SYSCTL register, FLAG2 is configured as $\overline{IRQ2}$. When Bit 19 is set (= 1) in the SYSCTL register, FLAG3 is configured as TIMEXP, which indicates that the system timer has expired. |
| DAI_P20–1 | I/O/T | Three-state with programmable pull-up | Digital Application Interface Pins. These pins provide the physical interface to the SRU. The SRU configuration registers define the combination of on-chip peripheral inputs or outputs connected to the pin and to the pin's output enable. The configuration registers of these peripherals then determine the exact behavior of the pin. Any input or output signal present in the SRU can be routed to any of these pins. The SRU provides the connection from the serial ports, input data port, precision clock generators, and timers to the DAI_P20–1 pins. These pins have internal 22.5 k Ω pull up resistors which are enabled on reset. These pull-ups can be disabled in the DAI_PIN_PULLUP register. |

Table 6. Pin Descriptions (Continued)

| Pin | Type | State During and After Reset | Function |
|---------------------------|-----------|---|---|
| SPICLK | I/O | Three-state with pull-up enabled, driven high in SPI-master boot mode | Serial Peripheral Interface Clock Signal. Driven by the master, this signal controls the rate at which data is transferred. The master can transmit data at a variety of baud rates. SPICLK cycles once for each bit transmitted. SPICLK is a gated clock that is active during data transfers, only for the length of the transferred word. Slave devices ignore the serial clock if the slave select input is driven inactive (HIGH). SPICLK is used to shift out and shift in the data driven on the MISO and MOSI lines. The data is always shifted out on one clock edge and sampled on the opposite edge of the clock. Clock polarity and clock phase relative to data are programmable into the SPICL control register and define the transfer format. SPICLK has a 22.5 k Ω internal pull-up resistor. If SPI master boot mode is selected, MOSI and SPICLK pins are driven during reset. These pins are not three-stated during reset in SPI master boot mode. |
| $\overline{\text{SPIDS}}$ | I | Input only | Serial Peripheral Interface Slave Device Select. An active low signal used to select the DSP as an SPI slave device. This input signal behaves like a chip select, and is provided by the master device for the slave devices. In multimaster mode, the DSP's $\overline{\text{SPIDS}}$ signal can be driven by a slave device to signal to the DSP (as SPI master) that an error has occurred, as some other device is also trying to be the master device. If asserted low when the device is in master mode, it is considered a multimaster error. For a single master, multiple-slave configuration where flag pins are used, this pin must be tied or pulled high to V_{DDEXT} on the master device. For ADSP-2126x to ADSP-2126x SPI interaction, any of the master ADSP-2126x's flag pins can be used to drive the $\overline{\text{SPIDS}}$ signal on the ADSP-2126x SPI slave device. |
| MOSI | I/O (O/D) | Three-state with pull-up enabled, driven low in SPI-master boot mode | SPI Master Out Slave In. If the ADSP-2126x is configured as a master, the MOSI pin becomes a data transmit (output) pin, transmitting output data. If the ADSP-2126x is configured as a slave, the MOSI pin becomes a data receive (input) pin, receiving input data. In an ADSP-2126x SPI interconnection, the data is shifted out from the MOSI output pin of the master and shifted into the MOSI input(s) of the slave(s). MOSI has a 22.5 k Ω internal pull-up resistor. If SPI master boot mode is selected, MOSI and SPICLK pins are driven during reset. These pins are not three-stated during reset in SPI master boot mode. |
| MISO | I/O (O/D) | Three-state with pull-up enabled | SPI Master In Slave Out. If the ADSP-2126x is configured as a master, the MISO pin becomes a data receive (input) pin, receiving input data. If the ADSP-2126x is configured as a slave, the MISO pin becomes a data transmit (output) pin, transmitting output data. In an ADSP-2126x SPI interconnection, the data is shifted out from the MISO output pin of the slave and shifted into the MISO input pin of the master. MISO has a 22.5 k Ω internal pull-up resistor. MISO can be configured as O/D by setting the OPD bit in the SPICL register. Note: Only one slave is allowed to transmit data at any given time. To enable broadcast transmission to multiple SPI slaves, the DSP's MISO pin can be disabled by setting (=1) Bit 5 (DMISO) of the SPICL register. |
| BOOT_CFG1-0 | I | Input only | Boot Configuration Select. Selects the boot mode for the DSP. The BOOT_CFG pins must be valid before reset is asserted. See Table 8 on Page 13 for a description of the boot modes. |
| CLKIN | I | Input only | Local Clock In. Used in conjunction with XTAL. CLKIN is the ADSP-2126x clock input. It configures the ADSP-2126x to use either its internal clock generator or an external clock source. Connecting the necessary components to CLKIN and XTAL enables the internal clock generator. Connecting the external clock to CLKIN while leaving XTAL unconnected configures the ADSP-2126x to use the external clock source such as an external clock oscillator. The core is clocked either by the PLL output or this clock input depending on the CLK_CFG1-0 pin settings. CLKIN should not be halted, changed, or operated below the specified frequency. |
| XTAL | O | Output only ² | Crystal Oscillator Terminal. Used in conjunction with CLKIN to drive an external crystal. |

ADSP-21261/ADSP-21262/ADSP-21266

Table 6. Pin Descriptions (Continued)

| Pin | Type | State During and After Reset | Function |
|------------------------------|---------|----------------------------------|--|
| CLK_CFG1-0 | I | Input only | Core/CLKIN Ratio Control. These pins set the start up clock frequency. See Table 9 for a description of the clock configuration modes. Note that the operating frequency can be changed by programming the PLL multiplier and divider in the PMCTL register at any time after the core comes out of reset. |
| $\overline{\text{RESETOUT}}$ | O | Output only | Reset Out. Drives out the core reset signal to an external device. |
| $\overline{\text{RESET}}$ | I/A | Input only | Processor Reset. Resets the ADSP-2126x to a known state. Upon deassertion, there is a 4096 CLKIN cycle latency for the PLL to lock. After this time, the core begins program execution from the hardware reset vector address. The $\overline{\text{RESET}}$ input must be asserted (low) at power-up. |
| TCK | I | Input only ³ | Test Clock (JTAG). Provides a clock for JTAG boundary scan. TCK must be asserted (pulsed low) after power-up or held low for proper operation of the ADSP-2126x. |
| TMS | I/S | Three-state with pull-up enabled | Test Mode Select (JTAG). Used to control the test state machine. TMS has a 22.5 k Ω internal pull-up resistor. |
| TDI | I/S | Three-state with pull-up enabled | Test Data Input (JTAG). Provides serial data for the boundary scan logic. TDI has a 22.5 k Ω internal pull-up resistor. |
| TDO | O | Three-state ⁴ | Test Data Output (JTAG). Serial scan output of the boundary scan path. |
| $\overline{\text{TRST}}$ | I/A | Three-state with pull-up enabled | Test Reset (JTAG). Resets the test state machine. $\overline{\text{TRST}}$ must be asserted (pulsed low) after power-up or held low for proper operation of the ADSP-2126x. $\overline{\text{TRST}}$ has a 22.5 k Ω internal pull-up resistor. |
| $\overline{\text{EMU}}$ | O (O/D) | Three-state with pull-up enabled | Emulation Status. Must be connected to the ADSP-2126x Analog Devices DSP Tools product line of JTAG emulators target board connector only. $\overline{\text{EMU}}$ has a 22.5 k Ω internal pull-up resistor. |
| V_{DDINT} | P | | Core Power Supply. Nominally +1.2 V dc and supplies the DSP's core processor (13 pins on the BGA package, 32 pins on the LQFP package). |
| V_{DDEXT} | P | | I/O Power Supply. Nominally +3.3 V dc (6 pins on the BGA package, 10 pins on the LQFP package). |
| A_{VDD} | P | | Analog Power Supply. Nominally +1.2 V dc and supplies the DSP's internal PLL (clock generator). This pin has the same specifications as V_{DDINT} , except that added filtering circuitry is required. For more information, see Power Supplies on Page 7. |
| A_{VSS} | G | | Analog Power Supply Return. |
| GND | G | | Power Supply Return. (54 pins on the BGA package, 39 pins on the LQFP package). |

¹ $\overline{\text{RD}}$, $\overline{\text{WR}}$, and ALE are continuously driven by the DSP and will not be three-stated.

² Output only is a three-state driver with its output path always enabled.

³ Input only is a three-state driver, with both output path and pull-up disabled.

⁴ Three-state is a three-state driver, with pull-up disabled.

ADDRESS DATA PINS AS FLAGS

To use these pins as flags (FLAG15–0), set (= 1) Bit 20 of the SYSCCTL register and disable the parallel port.

Table 7. AD15–0 to FLAG Pin Mapping

| AD Pin | Flag Pin | AD Pin | Flag Pin |
|--------|----------|--------|----------|
| AD0 | FLAG8 | AD8 | FLAG0 |
| AD1 | FLAG9 | AD9 | FLAG1 |
| AD2 | FLAG10 | AD10 | FLAG2 |
| AD3 | FLAG11 | AD11 | FLAG3 |
| AD4 | FLAG12 | AD12 | FLAG4 |
| AD5 | FLAG13 | AD13 | FLAG5 |
| AD6 | FLAG14 | AD14 | FLAG6 |
| AD7 | FLAG15 | AD15 | FLAG7 |

Boot Modes

Table 8. Boot Mode Selection

| BOOT_CFG1–0 | Booting Mode |
|-------------|------------------------------|
| 00 | SPI Slave Boot |
| 01 | SPI Master Boot |
| 10 | Parallel Port Boot via EPROM |
| 11 | Reserved |

CORE INSTRUCTION RATE TO CLKIN RATIO MODES

Table 9. Core Instruction Rate/CLKIN Ratio Selection

| CLK_CFG1–0 | Core to CLKIN Ratio |
|------------|---------------------|
| 00 | 3:1 |
| 01 | 16:1 |
| 10 | 8:1 |
| 11 | Reserved |

ADDRESS DATA MODES

Table 10 shows the functionality of the AD pins for 8-bit and 16-bit transfers to the parallel port. For 8-bit data transfers, ALE latches address bits A23–A8 when asserted, followed by address bits A7–A0 and data bits D7–D0 when deasserted. For 16-bit data transfers, ALE latches address bits A15–A0 when asserted, followed by data bits D15–D0 when deasserted.

Table 10. Address/Data Mode Selection

| EP Data Mode | ALE | AD7–0 Function | AD15–8 Function |
|--------------|------------|----------------|-----------------|
| 8-bit | Asserted | A15–8 | A23–16 |
| 8-bit | Deasserted | D7–0 | A7–0 |
| 16-bit | Asserted | A7–0 | A15–8 |
| 16-bit | Deasserted | D7–0 | D15–8 |

ADSP-21261/ADSP-21262/ADSP-21266

PRODUCT SPECIFICATIONS

OPERATING CONDITIONS

| Parameter ¹ | Description | Min | Max | Unit |
|--------------------------|--|------|--------------------------|------|
| V _{DDINT} | Internal (Core) Supply Voltage | 1.14 | 1.26 | V |
| A _{VDD} | Analog (PLL) Supply Voltage | 1.14 | 1.26 | V |
| V _{DDEXT} | External (I/O) Supply Voltage | 3.13 | 3.47 | V |
| V _{IH} | High Level Input Voltage ² @ V _{DDEXT} = Max | 2.0 | V _{DDEXT} + 0.5 | V |
| V _{IL} | Low Level Input Voltage ² @ V _{DDEXT} = Min | -0.5 | +0.8 | V |
| V _{IH_CLKIN} | High Level Input Voltage ³ @ V _{DDEXT} = Max | 1.74 | V _{DDEXT} + 0.5 | V |
| V _{IL_CLKIN} | Low Level Input Voltage @ V _{DDEXT} = Min | -0.5 | +1.19 | V |
| T _{AMB} K Grade | Ambient Operating Temperature ^{4, 5} | 0 | +70 | °C |
| T _{AMB} B Grade | Ambient Operating Temperature ^{4, 5} | -40 | +85 | °C |

¹Specifications subject to change without notice.

²Applies to input and bidirectional pins: AD15-0, FLAG3-0, DAI_Px, SPICLK, MOSI, MISO, $\overline{\text{SPIDS}}$, BOOT_CFGx, CLK_CFGx, $\overline{\text{RESET}}$, TCK, TMS, TDI, $\overline{\text{TRST}}$.

³Applies to input pin CLKIN.

⁴See [Thermal Characteristics on Page 37](#) for information on thermal specifications.

⁵See Engineer-to-Engineer Note (No. EE-216) for further information.

ELECTRICAL CHARACTERISTICS

| Parameter ¹ | Description | Test Conditions | Min | Max | Unit |
|------------------------|--|--|-----|-----|------|
| V _{OH} | High Level Output Voltage ² | @ V _{DDEXT} = Min, I _{OH} = -1.0 mA ³ | 2.4 | | V |
| V _{OL} | Low Level Output Voltage ² | @ V _{DDEXT} = Min, I _{OL} = 1.0 mA ³ | | 0.4 | V |
| I _{IH} | High Level Input Current ^{4, 5} | @ V _{DDEXT} = Max, V _{IN} = V _{DDEXT} Max | | 10 | μA |
| I _{IL} | Low Level Input Current ⁴ | @ V _{DDEXT} = Max, V _{IN} = 0 V | | 10 | μA |
| I _{ILPU} | Low Level Input Current Pull-Up ⁵ | @ V _{DDEXT} = Max, V _{IN} = 0 V | | 200 | μA |
| I _{OZH} | Three-State Leakage Current ^{6, 7, 8} | @ V _{DDEXT} = Max, V _{IN} = V _{DDEXT} Max | | 10 | μA |
| I _{OZL} | Three-State Leakage Current ⁶ | @ V _{DDEXT} = Max, V _{IN} = 0 V | | 10 | μA |
| I _{OZLPU} | Three-State Leakage Current Pull-Up ⁷ | @ V _{DDEXT} = Max, V _{IN} = 0 V | | 200 | μA |
| I _{DD-INTYP} | Supply Current (Internal) ^{9, 10, 11} | t _{CCLK} = 5.0 ns, V _{DDINT} = 1.2 V, T _{AMB} = +25°C | | 500 | mA |
| I _{AVDD} | Supply Current (Analog) ¹¹ | A _{VDD} = Max | | 10 | mA |
| C _{IN} | Input Capacitance ^{12, 13} | f _{IN} = 1 MHz, T _{CASE} = 25°C, V _{IN} = 1.2 V | | 4.7 | pF |

¹Specifications subject to change without notice.

²Applies to output and bidirectional pins: AD15-0, $\overline{\text{RD}}$, $\overline{\text{WR}}$, ALE, FLAG3-0, DAI_Px, SPICLK, MOSI, MISO, $\overline{\text{EMU}}$, TDO, CLKOUT, XTAL.

³See [Output Drive Currents on Page 36](#) for typical drive current capabilities.

⁴Applies to input pins: SPIDS, BOOT_CFGx, CLK_CFGx, TCK, RESET, CLKIN.

⁵Applies to input pins with 22.5 kΩ internal pull-ups: $\overline{\text{TRST}}$, TMS, TDI.

⁶Applies to three-statable pins: FLAG3-0.

⁷Applies to three-statable pins with 22.5 kΩ pull-ups: AD15-0, DAI_Px, SPICLK, MISO, MOSI.

⁸Applies to open-drain output pins: $\overline{\text{EMU}}$, MISO, MOSI.

⁹Typical internal current data reflects nominal operating conditions.

¹⁰See Engineer-to-Engineer Note (EE-216) for further information.

¹¹Characterized, but not tested.

¹²Applies to all signal pins.

¹³Guaranteed, but not tested.

PACKAGE INFORMATION

The information presented in [Figure 3](#) provides details about the package branding for the ADSP-21266 processors. For a complete listing of product availability, see [Ordering Guide on Page 44](#).



Figure 3. Typical Package Brand

Table 11. Package Brand Information

| Brand Key | Field Description |
|-----------|----------------------------------|
| t | Temperature Range |
| pp | Package Type |
| Z | RoHS Compliant Option (optional) |
| cc | See Ordering Guide |
| vvvvv.x | Assembly Lot Code |
| n.n | Silicon Revision |
| # | RoHS Compliant Designation |
| yyww | Date Code |

ESD CAUTION



ESD (electrostatic discharge) sensitive device. Charged devices and circuit boards can discharge without detection. Although this product features patented or proprietary protection circuitry, damage may occur on devices subjected to high energy ESD. Therefore, proper ESD precautions should be taken to avoid performance degradation or loss of functionality.

MAXIMUM POWER DISSIPATION

See *Estimating Power for the ADSP-21262 SHARC Processors (EE-216)* for detailed thermal and power information regarding maximum power dissipation. For information on package thermal specifications, see [Thermal Characteristics on Page 37](#).

ABSOLUTE MAXIMUM RATINGS

Stresses greater than those listed in [Table 12](#) may cause permanent damage to the device. These are stress ratings only; functional operation of the device at these or any other conditions greater than those indicated in the operational sections of this specification is not implied. Exposure to absolute maximum rating conditions for extended periods may affect device reliability.

Table 12. Absolute Maximum Ratings

| Parameter | Rating |
|--|------------------|
| Internal (Core) Supply Voltage (V_{DDINT}) | -0.3 V to +1.4 V |
| Analog (PLL) Supply Voltage (A_{VDD}) | -0.3 V to +1.4 V |
| External (I/O) Supply Voltage (V_{DDEXT}) | -0.3 V to +3.8 V |
| Input Voltage -0.5 V to V_{DDEXT} | +0.5 V |
| Output Voltage Swing -0.5 V to V_{DDEXT} | +0.5 V |
| Load Capacitance | 200 pF |
| Storage Temperature Range | -65°C to +150°C |
| Junction Temperature Under Bias | 125°C |

TIMING SPECIFICATIONS

Use the exact timing information given. Do not attempt to derive parameters from the addition or subtraction of others. While addition or subtraction would yield meaningful results for an individual device, the values given in this data sheet reflect statistical variations and worst cases. Consequently, it is not meaningful to add parameters to derive longer times.

Timing requirements apply to signals that are controlled by circuitry external to the processor, such as the data input for a read operation. Timing requirements guarantee that the processor operates correctly with other devices.

Switching characteristics specify how the processor changes its signals. Circuitry external to the processor must be designed for compatibility with these signal characteristics. Switching characteristics describe what the processor will do in a given circumstance. Use switching characteristics to ensure that any timing requirement of a device connected to the processor (such as memory) is satisfied.

Core Clock Requirements

The processor's internal clock (a multiple of CLKIN) provides the clock signal for timing internal memory, processor core, serial ports, and parallel port (as required for read/write strobes in asynchronous access mode). During reset, program the ratio between the DSP's internal clock frequency and external (CLKIN) clock frequency with the CLK_CFG1-0 pins. To determine switching frequencies for the serial ports, divide down the internal clock, using the programmable divider control of each port (DIVx for the serial ports).

The processor's internal clock switches at higher frequencies than the system input clock (CLKIN). To generate the internal clock, the DSP uses an internal phase-locked loop (PLL). This PLL-based clocking minimizes the skew between the system clock (CLKIN) signal and the DSP's internal clock (the clock source for the parallel port logic and I/O pads).

ADSP-21261/ADSP-21262/ADSP-21266

Voltage Controlled Oscillator

In application designs, the PLL multiplier value should be selected in such a way that the VCO frequency never exceeds f_{VCO} specified in Table 16.

- The product of CLKIN and PLLM must never exceed 1/2 of f_{VCO} (max) in Table 16 if the input divider is not enabled (INDIV = 0).
- The product of CLKIN and PLLM must never exceed f_{VCO} (max) in Table 16 if the input divider is enabled (INDIV = 1).

The VCO frequency is calculated as follows:

$$f_{VCO} = 2 \times PLLM \times f_{INPUT}$$

$$f_{CCLK} = (2 \times PLLM \times f_{INPUT}) \div (2 \times PLLD)$$

where:

$$f_{VCO} = \text{VCO output}$$

PLLM = Multiplier value programmed in the PMCTL register. During reset, the PLLM value is derived from the ratio selected using the CLK_CFG pins in hardware.

PLLD = 2, 4, 8, 16 based on the PLLD value programmed on the PMCTL register. During reset this value is 1.

f_{INPUT} = is the input frequency to the PLL.

f_{INPUT} = CLKIN when the input divider is disabled or

f_{INPUT} = CLKIN ÷ 2 when the input divider is enabled

Note the definitions of various clock periods that are a function of CLKIN and the appropriate ratio control shown in Table 13 and Table 14.

Table 13. CLKOUT and CCLK Clock Generation Operation

| Timing Requirements | Description | Calculation |
|---------------------|-------------|------------------------|
| CLKIN | Input Clock | $1/t_{CK}$ |
| CCLK | Core Clock | Variable, see equation |

Table 14. Clock Periods

| Timing Requirements | Description ¹ |
|---------------------|---|
| t_{CK} | CLKIN Clock Period |
| t_{CCLK} | (Processor) Core Clock Period |
| t_{MCLK} | Internal memory clock = $1/2 t_{CCLK}$ |
| t_{SCLK} | Serial Port Clock Period = $(t_{CCLK}) \times SR$ |
| t_{SPICLK} | SPI Clock Period = $(t_{CCLK}) \times SPIR$ |

¹ where:

SR = serial port-to-core clock ratio (wide range, determined by SPORT CLKDIV)

SPIR = SPI-to-core clock ratio (wide range, determined by SPIBAUD register)

SCLK = serial port clock

SPICLK = SPI clock

Figure 4 shows core to CLKIN relationships with external oscillator or crystal. The shaded divider/multiplier blocks denote where clock ratios can be set through hardware or software using the power management control register (PMCTL). For more information, see the ADSP-2126x SHARC Processor Peripherals Reference and Managing the Core PLL on Third-Generation SHARC Processors (EE-290).

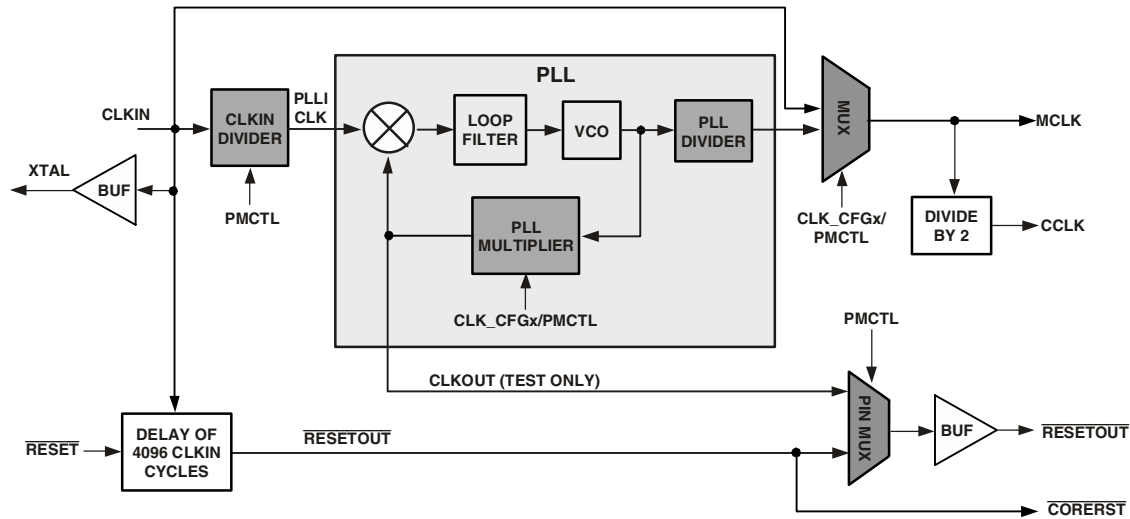

Figure 4. Core Clock and System Clock Relationship to CLKIN

Power-Up Sequencing

The timing requirements for DSP startup are given in [Table 15](#) and [Figure 5](#). Note that during power-up, a leakage current of approximately 200µA may be observed on the $\overline{\text{RESET}}$ pin. This leakage current results from the weak internal pull-up resistor on this pin being enabled during power-up.

Table 15. Power-Up Sequencing (DSP Startup)

| Parameter | | Min | Max | Unit |
|----------------------------------|---|------------------------------------|------|------|
| <i>Timing Requirements</i> | | | | |
| t_{RSTVDD} | $\overline{\text{RESET}}$ Low Before $V_{\text{DDINT}}/V_{\text{DDEXT}}$ On | 0 | | ns |
| t_{IVDDEVDD} | V_{DDINT} On Before V_{DDEXT} | -50 | +200 | ms |
| t_{CLKVDD} | CLKIN Valid After $V_{\text{DDINT}}/V_{\text{DDEXT}}$ Valid ¹ | 0 | 200 | ms |
| t_{CLKRST} | CLKIN Valid Before $\overline{\text{RESET}}$ Deasserted | 10^2 | | µs |
| t_{PLLRST} | PLL Control Setup Before $\overline{\text{RESET}}$ Deasserted | 20^3 | | µs |
| <i>Switching Characteristics</i> | | | | |
| t_{CORERST} | DSP Core Reset Deasserted After $\overline{\text{RESET}}$ Deasserted | $4096 \times t_{\text{CK}}^{4, 5}$ | | |

¹ Valid $V_{\text{DDINT}}/V_{\text{DDEXT}}$ assumes that the supplies are fully ramped to their 1.2 V and 3.3 V rails. Voltage ramp rates can vary from microseconds to hundreds of milliseconds depending on the design of the power supply subsystem.

² Assumes a stable CLKIN signal, after meeting worst-case startup timing of crystal oscillators. Refer to the crystal oscillator manufacturer's data sheet for startup time. Assume a 25 ms maximum oscillator startup time if using the XTAL pin and internal oscillator circuit in conjunction with an external crystal.

³ Based on CLKIN cycles.

⁴ Applies after the power-up sequence is complete. Subsequent resets require a minimum of four CLKIN cycles for $\overline{\text{RESET}}$ to be held low in order to properly initialize and propagate default states at all I/O pins.

⁵ The 4096 cycle count depends on t_{SRST} specification in [Table 17](#). If setup time is not met, one additional CLKIN cycle can be added to the core reset time, resulting in 4097 cycles maximum.

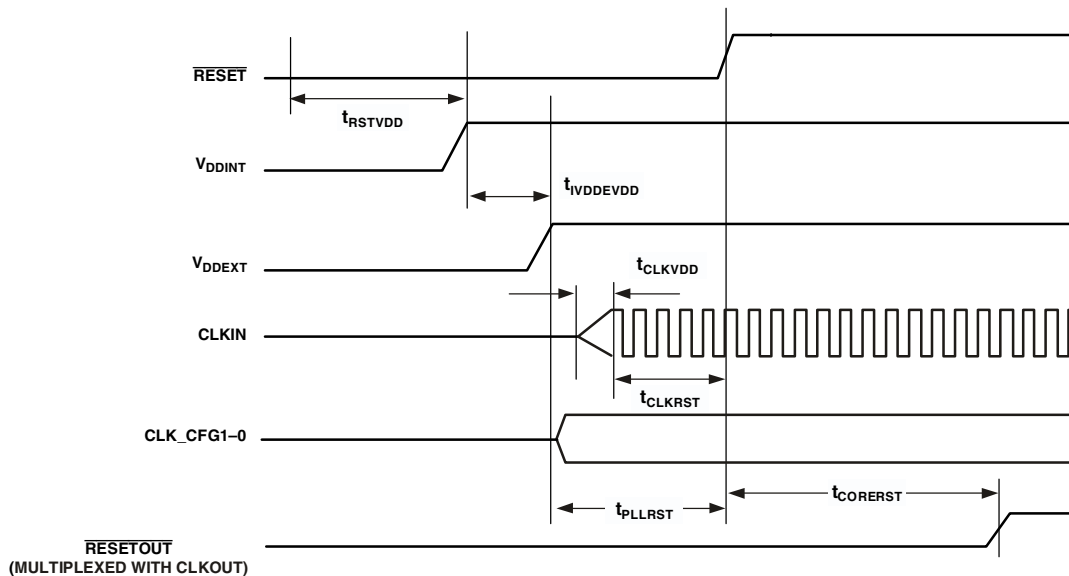

Figure 5. Power-Up Sequencing

ADSP-21261/ADSP-21262/ADSP-21266

Clock Input

See [Table 16](#) and [Figure 6](#).

Table 16. Clock Input

| Parameter | 150 MHz ¹ | | 200 MHz ² | | Unit |
|-------------------------------|----------------------------------|-----|----------------------|------------------|------|
| | Min | Max | Min | Max | |
| <i>Timing Requirements</i> | | | | | |
| t _{CK} | CLKIN Period | | 15 ³ | 160 ⁴ | ns |
| t _{CKL} | CLKIN Width Low | | 6 ³ | 80 ⁴ | ns |
| t _{CKH} | CLKIN Width High | | 6 ³ | 80 ⁴ | ns |
| t _{CKRF} | CLKIN Rise/Fall (0.4 V to 2.0 V) | | | 3 | ns |
| f _{VCO} ⁵ | VCO Frequency | | 200 | 800 | MHz |
| t _{CCLK} | CCLK Period ⁶ | | 5 | 10 | ns |

¹ Applies to all 150 MHz models. See [Ordering Guide on Page 44](#).

² Applies to all 200 MHz models. See [Ordering Guide on Page 44](#).

³ Applies only for CLK_CFG1-0 = 00 and default values for PLL control bits in PMCTL.

⁴ Applies only for CLK_CFG1-0 = 01 and default values for PLL control bits in PMCTL.

⁵ See [Figure 4 on Page 16](#) for VCO diagram.

⁶ Any changes to PLL control bits in the PMCTL register must meet core clock timing specification t_{CCLK}.

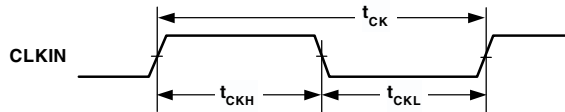
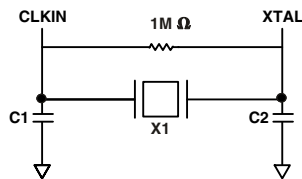

Figure 6. Clock Input

Clock Signals

The ADSP-2126x can use an external clock or a crystal. See CLKIN pin description. The programmer can configure the ADSP-2126x to use its internal clock generator by connecting the necessary components to CLKIN and XTAL. [Figure 7](#) shows the component connections used for a crystal operating in fundamental mode. Note that the 200 MHz clock rate is achieved using a 12.5 MHz crystal and a PLL multiplier ratio 16:1 (CCLK:CLKIN).



NOTE: C1 AND C2 ARE SPECIFIC TO CRYSTAL SPECIFIED FOR X1. CONTACT CRYSTAL MANUFACTURER FOR DETAILS. CRYSTAL SELECTION MUST COMPLY WITH CLKCFG1-0 = 10 OR = 01.

Figure 7. 150 MHz or 200 MHz Operation with a 12.5 MHz Fundamental Mode Crystal

Reset

See [Table 17](#) and [Figure 8](#).

Table 17. Reset

| Parameter | Min | Max | Unit |
|--|-------------------|-----|------|
| <i>Timing Requirements</i> | | | |
| t_{WRST} \overline{RESET} Pulse Width Low ¹ | $4 \times t_{CK}$ | | ns |
| t_{SRST} \overline{RESET} Setup Before CLKIN Low | 8 | | ns |

¹Applies after the power-up sequence is complete. At power-up, the processor's internal phase-locked loop requires no more than 100 μ s while \overline{RESET} is low, assuming stable VDD and CLKIN (not including start-up time of external clock oscillator).

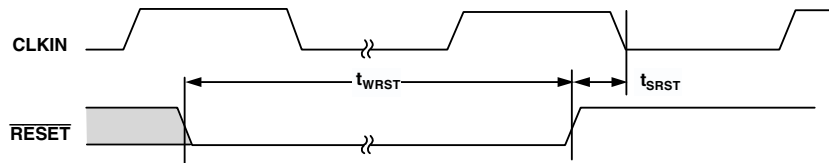

Figure 8. Reset

Interrupts

The timing specification in [Table 18](#) and [Figure 9](#) applies to the FLAG0, FLAG1, and FLAG2 pins when they are configured as $\overline{IRQ0}$, $\overline{IRQ1}$, and $\overline{IRQ2}$ interrupts. Also applies to DAI_P20-1 pins when configured as interrupts.

Table 18. Interrupts

| Parameter | Min | Max | Unit |
|---|------------------|-----|------|
| <i>Timing Requirements</i> | | | |
| t_{IPW} \overline{IRQx} Pulse Width | $2 t_{CCLK} + 2$ | | ns |

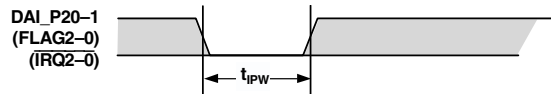

Figure 9. Interrupts

ADSP-21261/ADSP-21262/ADSP-21266

Core Timer

The timing specification in Table 19 and Figure 10 applies to FLAG3 when it is configured as the core timer (CTIMER).

Table 19. Core Timer

| Parameter | Min | Max | Unit |
|----------------------------------|-------------------------|-----|------|
| <i>Switching Characteristics</i> | | | |
| t_{WCTIM} CTIMER Pulse Width | $4 \times t_{CCLK} - 1$ | | ns |

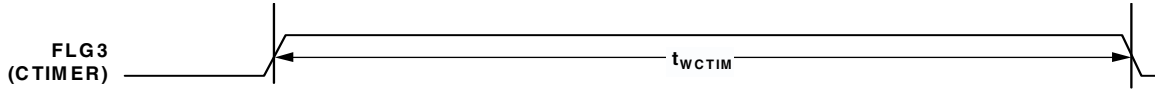

Figure 10. Core Timer

Timer PWM_OUT Cycle Timing

The timing specification in Table 20 and Figure 11 applies to Timer in PWM_OUT (pulse-width modulation) mode. Timer signals are routed to the DAI_P20-1 pins through the SRU. Therefore, the timing specifications provided below are valid at the DAI_P20-1 pins.

Table 20. Timer PWM_OUT Timing

| Parameter | Min | Max | Unit |
|-------------------------------------|-------------------------|---------------------------------|------|
| <i>Switching Characteristics</i> | | | |
| t_{PWMO} Timer Pulse Width Output | $2 \times t_{CCLK} - 1$ | $2(2^{31} - 1) \times t_{CCLK}$ | ns |

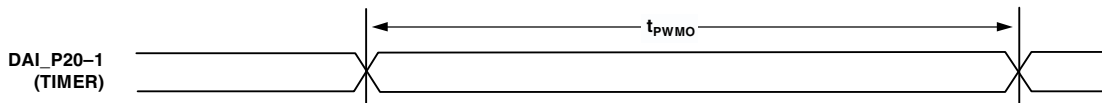

Figure 11. Timer PWM_OUT Timing

Timer WDT_H_CAP Timing

The timing specification in Table 21 and Figure 12 applies to Timer in WDT_H_CAP (pulse width count and capture) mode. Timer signals are routed to the DAI_P20-1 pins through the SRU. Therefore, the timing specifications provided below are valid at the DAI_P20-1 pins.

Table 21. Timer Width Capture Timing

| Parameter | Min | Max | Unit |
|-----------------------------|---------------------|---------------------------------|------|
| <i>Timing Requirements</i> | | | |
| t_{PWI} Timer Pulse Width | $2 \times t_{CCLK}$ | $2(2^{31} - 1) \times t_{CCLK}$ | ns |

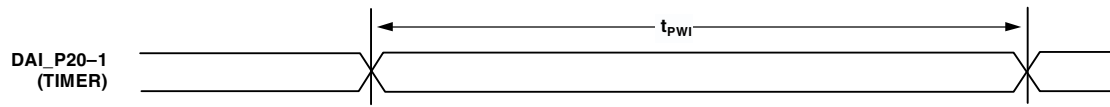

Figure 12. Timer Width Capture Timing

DAI Pin-to-Pin Direct Routing

See Table 22 and Figure 13 for direct pin connections only (for example, DAI_PB01_I to DAI_PB02_O).

Table 22. DAI Pin-to-Pin Routing

| Parameter | Min | Max | Unit |
|--|-----|-----|------|
| <i>Timing Requirements</i> | | | |
| t_{DPiO} Delay DAI Pin Input Valid to DAI Output Valid | 1.5 | 10 | ns |

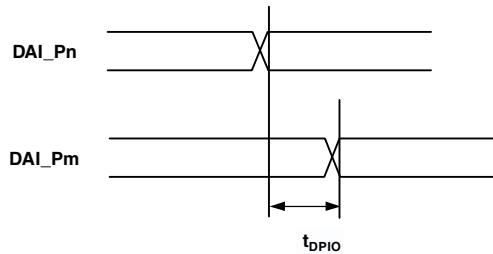

Figure 13. DAI Pin-to-Pin Direct Routing

ADSP-21261/ADSP-21262/ADSP-21266

Precision Clock Generator (Direct Pin Routing)

The timing in Table 23 and Figure 14 is valid only when the SRU is configured such that the precision clock generator (PCG) takes its inputs directly from the DAI pins (via pin buffers) and sends its outputs directly to the DAI pins. For the other

cases where the PCG's inputs and outputs are not directly routed to/from DAI pins (via pin buffers), there is no timing data available. All timing parameters and switching characteristics apply to external DAI pins (DAI_P07–DAI_P20).

Table 23. Precision Clock Generator (Direct Pin Routing)

| Parameter | | Min | Max | Unit |
|----------------------------------|--|------------------------------|-----------------------------|------|
| <i>Timing Requirements</i> | | | | |
| t_{PCGIW} | Input Clock Pulse Width | 20 | | ns |
| t_{STRIG} | PCG Trigger Setup Before Falling Edge of PCG Input Clock | 2 | | ns |
| t_{HTRIG} | PCG Trigger Hold After Falling Edge of PCG Input Clock | 2 | | ns |
| <i>Switching Characteristics</i> | | | | |
| t_{DPCGIO} | PCG Output Clock and Frame Sync Active Edge Delay After PCG Input Clock Falling Edge | 2.5 | 10 | ns |
| t_{DTRIG} | PCG Output Clock and Frame Sync Delay After PCG Trigger | $2.5 + 2.5 \times t_{PCGOW}$ | $10 + 2.5 \times t_{PCGOW}$ | ns |
| t_{PCGOW} | Output Clock Pulse Width | 40 | | ns |

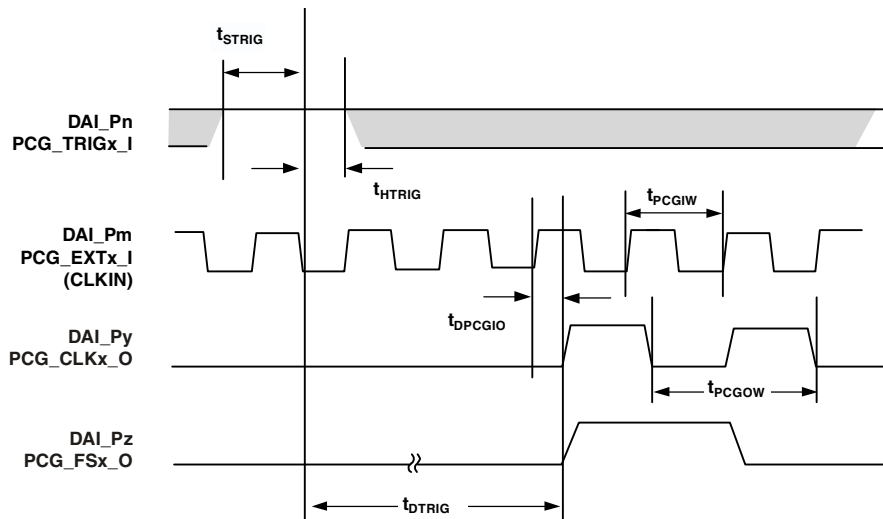

Figure 14. Precision Clock Generator (Direct Pin Routing)

Flags

The timing specifications in Table 24 and Figure 15 apply to the FLAG3-0 and DAI_P20-1 pins, the parallel port, and the serial peripheral interface. See Table 6 on Page 10 for more information on flag use.

Table 24. Flags

| Parameter | Min | Max | Unit |
|------------------------------------|-------------------------|-----|------|
| <i>Timing Requirements</i> | | | |
| t_{FIPW} FLAG3-0 IN Pulse Width | $2 \times t_{CCLK} + 3$ | | ns |
| <i>Switching Characteristics</i> | | | |
| t_{FOPW} FLAG3-0 OUT Pulse Width | $2 \times t_{CCLK} - 1$ | | ns |

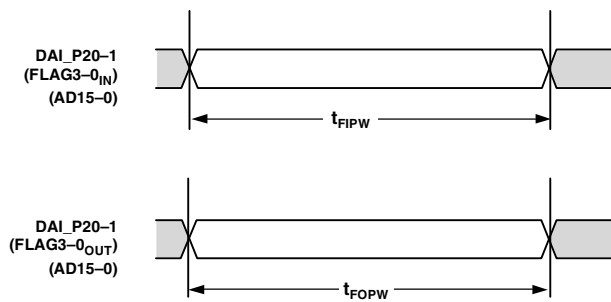

Figure 15. Flags

ADSP-21261/ADSP-21262/ADSP-21266

Memory Read—Parallel Port

The specifications in Table 25, Table 26, Figure 16, and Figure 17 are for asynchronous interfacing to memories (and memory-mapped peripherals) when the ADSP-2126x is accessing external memory space.

Table 25. 8-Bit Memory Read Cycle

| Parameter | Min | Max | Unit |
|----------------------------------|--|---------------------------------|-----------------------------|
| <i>Timing Requirements</i> | | | |
| t_{DRS} | Address/Data 7–0 Setup Before \overline{RD} High | 3.3 | ns |
| t_{DRH} | Address/Data 7–0 Hold After \overline{RD} High | 0 | ns |
| t_{DAD} | Address 15–8 to Data Valid | $D + 0.5 \times t_{CCLK} - 3.5$ | ns |
| <i>Switching Characteristics</i> | | | |
| t_{ALEW} | ALE Pulse Width | $2 \times t_{CCLK} - 2$ | ns |
| t_{ALERW} | ALE Deasserted to Read/Write Asserted | $1 \times t_{CCLK} - 0.5$ | ns |
| t_{ADAS}^1 | Address/Data 15–0 Setup Before ALE Deasserted | $2.5 \times t_{CCLK} - 2.0$ | ns |
| t_{ADAH}^1 | Address/Data 15–0 Hold After ALE Deasserted | $0.5 \times t_{CCLK} - 0.8$ | ns |
| t_{ALEHZ}^1 | ALE Deasserted to Address/Data 7–0 in High-Z | $0.5 \times t_{CCLK} - 0.8$ | $0.5 \times t_{CCLK} + 2.0$ |
| t_{RW} | \overline{RD} Pulse Width | $D - 2$ | ns |
| t_{ADRH} | Address/Data 15–8 Hold After \overline{RD} High | $0.5 \times t_{CCLK} - 1 + H$ | ns |

$D = (\text{The value set by the PPDUR Bits (5–1) in the PPCTL register}) \times t_{CCLK}$

$H = t_{CCLK}$ (if a hold cycle is specified, else $H = 0$)

¹ On reset, ALE is an active high cycle. However, it can be reconfigured by software to be active low.

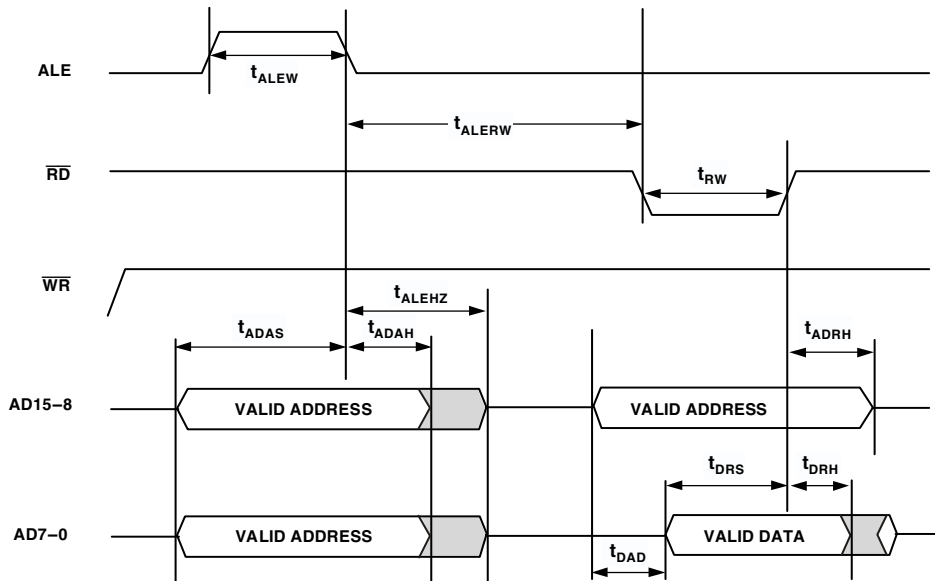

Figure 16. 8-Bit Memory Read Cycle

Table 26. 16-Bit Memory Read Cycle

| Parameter | | Min | Max | Unit |
|----------------------------------|---|-----------------------------|-----------------------------|------|
| <i>Timing Requirements</i> | | | | |
| t_{DRS} | Address/Data 15-0 Setup Before \overline{RD} high | 3.3 | | ns |
| t_{DRH} | Address/Data 15-0 Hold After \overline{RD} high | 0 | | ns |
| <i>Switching Characteristics</i> | | | | |
| t_{ALEW} | ALE Pulse Width | $2 \times t_{CCLK} - 2$ | | ns |
| t_{ALERW} | ALE Deasserted to Read/Write Asserted | $1 \times t_{CCLK} - 0.5$ | | ns |
| t_{ADAS}^1 | Address/Data 15-0 Setup Before ALE Deasserted | $2.5 \times t_{CCLK} - 2.0$ | | ns |
| t_{ADAH}^1 | Address/Data 15-0 Hold After ALE Deasserted | $0.5 \times t_{CCLK} - 0.8$ | | ns |
| t_{ALEHZ}^1 | ALE Deasserted to Address/Data 15-0 in High-Z | $0.5 \times t_{CCLK} - 0.8$ | $0.5 \times t_{CCLK} + 2.0$ | ns |
| t_{RW} | \overline{RD} Pulse Width | $D - 2$ | | ns |

$D = (\text{The value set by the PPDUR Bits (5-1) in the PPCTL register}) \times t_{CCLK}$

$H = t_{CCLK}$ (if a hold cycle is specified, else $H = 0$)

¹ On reset, ALE is an active high cycle. However, it can be reconfigured by software to be active low.

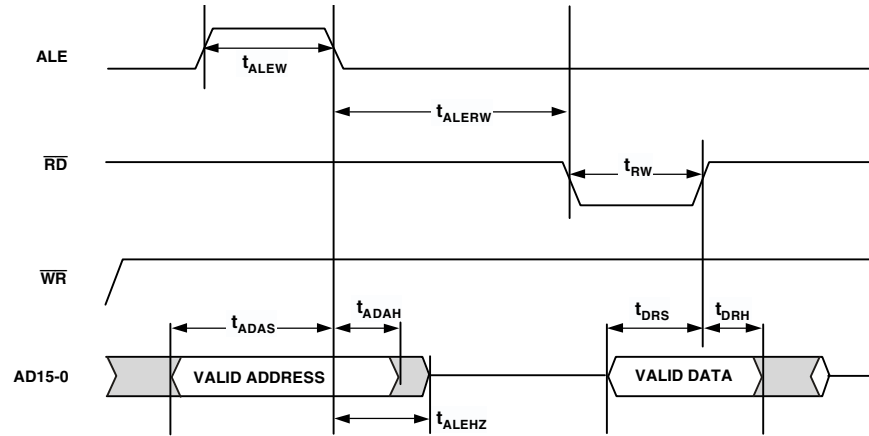

Figure 17. 16-Bit Memory Read Cycle

ADSP-21261/ADSP-21262/ADSP-21266

Memory Write—Parallel Port

Use the specifications in Table 27, Table 28, Figure 18, and Figure 19 for asynchronous interfacing to memories (and memory-mapped peripherals) when the ADSP-2126x is accessing external memory space.

Table 27. 8-Bit Memory Write Cycle

| Parameter | Min | Max | Unit |
|----------------------------------|--|---------------------------------|--------------------------------|
| <i>Switching Characteristics</i> | | | |
| t_{ALEW} | ALE Pulse Width | $2 \times t_{CCLK} - 2$ | ns |
| t_{ALERW} | ALE Deasserted to Read/Write Asserted | $1 \times t_{CCLK} - 0.5$ | ns |
| t_{ADAS}^1 | Address/Data 15–0 Setup Before ALE Deasserted | $2.5 \times t_{CCLK} - 2.0$ | ns |
| t_{ADAH}^1 | Address/Data 15–0 Hold After ALE Deasserted | $0.5 \times t_{CCLK} - 0.8$ | ns |
| t_{WW} | \overline{WR} Pulse Width | $D - 2$ | ns |
| t_{ADWL} | Address/Data 15–8 to \overline{WR} Low | $0.5 \times t_{CCLK} - 1.5$ | ns |
| t_{ADWH} | Address/Data 15–8 Hold After \overline{WR} High | $0.5 \times t_{CCLK} - 1 + H$ | ns |
| t_{ALEHZ} | ALE Deasserted to Address/Data 15–0 in High-Z | $0.5 \times t_{CCLK} - 0.8$ | $0.5 \times t_{CCLK} + 2.0$ ns |
| t_{DWS} | Address/Data 7–0 Setup Before \overline{WR} High | D | ns |
| t_{DWH} | Address/Data 7–0 Hold After \overline{WR} High | $0.5 \times t_{CCLK} - 1.5 + H$ | ns |
| t_{DAWH} | Address/Data to \overline{WR} High | D | ns |

D = (The value set by the PPDUR Bits (5–1) in the PPCTL register) $\times t_{CCLK}$

H = t_{CCLK} (if a hold cycle is specified, else H = 0)

¹ On reset, ALE is an active high cycle. However, it can be reconfigured by software to be active low.

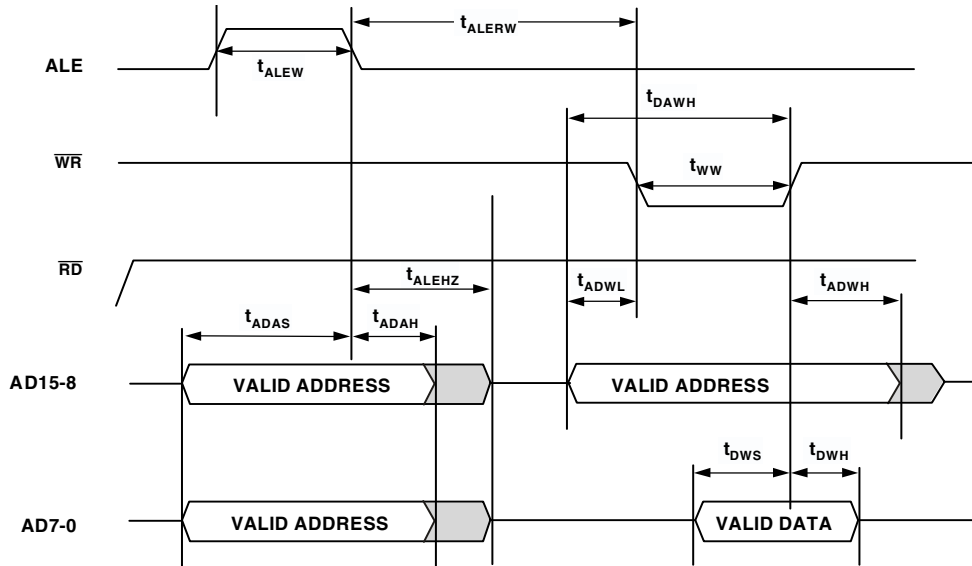

Figure 18. 8-Bit Memory Write Cycle

Table 28. 16-Bit Memory Write Cycle

| Parameter | | Min | Max | Unit |
|----------------------------------|---|---------------------------------|-----------------------------|------|
| <i>Switching Characteristics</i> | | | | |
| t_{ALEW} | ALE Pulse Width | $2 \times t_{CCLK} - 2$ | | ns |
| t_{ALERW} | ALE Deasserted to Read/Write Asserted | $1 \times t_{CCLK} - 0.5$ | | ns |
| t_{ADAS}^1 | Address/Data 15-0 Setup Before ALE Deasserted | $2.5 \times t_{CCLK} - 2.0$ | | ns |
| t_{ADAH}^1 | Address/Data 15-0 Hold After ALE Deasserted | $0.5 \times t_{CCLK} - 0.8$ | | ns |
| t_{WW} | \overline{WR} Pulse Width | $D - 2$ | | ns |
| t_{ALEHZ}^1 | ALE Deasserted to Address/Data 15-0 in High-Z | $0.5 \times t_{CCLK} - 0.8$ | $0.5 \times t_{CCLK} + 2.0$ | ns |
| t_{DWS} | Address/Data 15-0 Setup Before \overline{WR} High | D | | ns |
| t_{DWH} | Address/Data 15-0 Hold After \overline{WR} High | $0.5 \times t_{CCLK} - 1.5 + H$ | | ns |

D = (The value set by the PPDUR Bits (5-1) in the PPCTL register) $\times t_{CCLK}$

H = t_{CCLK} (if a hold cycle is specified, else H = 0)

¹On reset, ALE is an active high cycle. However, it can be reconfigured by software to be active low.

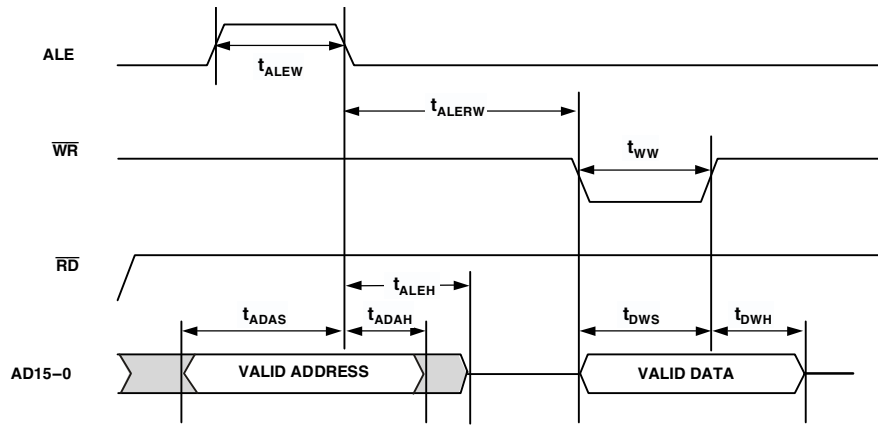

Figure 19. 16-Bit Memory Write Cycle

ADSP-21261/ADSP-21262/ADSP-21266

Serial Ports

To determine whether communication is possible between two devices at a given clock speed, the specifications in [Table 29](#), [Table 30](#), [Table 31](#), [Table 32](#), [Figure 20](#), and [Figure 21](#) must be confirmed: 1) frame sync delay and frame sync setup and hold; 2) data delay and data setup and hold; and 3) SCLK width.

Serial port signals (SCLK, FS, DxA,/DxB) are routed to the DAI_P20–1 pins using the SRU. Therefore, the timing specifications provided below are valid at the DAI_P20–1 pins.

Table 29. Serial Ports—External Clock

| Parameter | Min | Max | Unit |
|---|-----|-----|------|
| <i>Timing Requirements</i> | | | |
| t _{SFSE} FS Setup Before SCLK (Externally Generated FS in Either Transmit or Receive Mode) ¹ | 2.5 | | ns |
| t _{HFSE} FS Hold After SCLK (Externally Generated FS in Either Transmit or Receive Mode) ¹ | 2.5 | | ns |
| t _{SDRE} Receive Data Setup Before Receive SCLK ¹ | 2.5 | | ns |
| t _{HDRE} Receive Data Hold After SCLK ¹ | 2.5 | | ns |
| t _{SCLKW} SCLK Width | 7 | | ns |
| t _{SCLK} SCLK Period | 20 | | ns |
| <i>Switching Characteristics</i> | | | |
| t _{DFSE} FS Delay After SCLK (Internally Generated FS in Either Transmit or Receive Mode) ² | | 7 | ns |
| t _{HOFSE} FS Hold After SCLK (Internally Generated FS in Either Transmit or Receive Mode) ² | 2 | | ns |
| t _{DDTE} Transmit Data Delay After Transmit SCLK ² | | 7 | ns |
| t _{HDTE} Transmit Data Hold After Transmit SCLK ² | 2 | | ns |

¹Referenced to sample edge.

²Referenced to drive edge.

Table 30. Serial Ports—Internal Clock

| Parameter | Min | Max | Unit |
|---|--------------------------|--------------------------|------|
| <i>Timing Requirements</i> | | | |
| t _{SFSI} FS Setup Before SCLK (Externally Generated FS in Either Transmit or Receive Mode) ¹ | 6 | | ns |
| t _{HFSI} FS Hold After SCLK (Externally Generated FS in Either Transmit or Receive Mode) ¹ | 1.5 | | ns |
| t _{SDRI} Receive Data Setup Before SCLK ¹ | 6 | | ns |
| t _{HDRI} Receive Data Hold After SCLK ¹ | 1.5 | | ns |
| <i>Switching Characteristics</i> | | | |
| t _{DFSI} FS Delay After SCLK (Internally Generated FS in Transmit Mode) ² | | 3 | ns |
| t _{HOFSI} FS Hold After SCLK (Internally Generated FS in Transmit Mode) ² | –1.0 | | ns |
| t _{DFSI} FS Delay After SCLK (Internally Generated FS in Receive Mode) ² | | 3 | ns |
| t _{HOFSI} FS Hold After SCLK (Internally Generated FS in Receive Mode) ² | –1.0 | | ns |
| t _{DDTI} Transmit Data Delay After SCLK ² | | 3 | ns |
| t _{HDTI} Transmit Data Hold After SCLK ² | –1.0 | | ns |
| t _{SCLKIW} Transmit or Receive SCLK Width | 0.5t _{SCLK} – 2 | 0.5t _{SCLK} + 2 | ns |

¹Referenced to the sample edge.

²Referenced to drive edge.

Table 31. Serial Ports—Enable and Three-State

| Parameter | | Min | Max | Unit |
|----------------------------------|---|-----|-----|------|
| <i>Switching Characteristics</i> | | | | |
| t_{DDTEN} | Data Enable from External Transmit SCLK ¹ | 2 | | ns |
| t_{DDTTE} | Data Disable from External Transmit SCLK ¹ | | 7 | ns |
| t_{DDTIN} | Data Enable from Internal Transmit SCLK ¹ | -1 | | ns |

¹Referenced to drive edge.

Table 32. Serial Ports—External Late Frame Sync

| Parameter | | Min | Max | Unit |
|----------------------------------|---|-----|-----|------|
| <i>Switching Characteristics</i> | | | | |
| $t_{DDTLFSE}$ | Data Delay from Late External Transmit FS or External Receive FS with MCE = 1, MFD = 0 ¹ | | 7 | ns |
| $t_{DDTENFS}$ | Data Enable for MCE = 1, MFD = 0 ¹ | 0.5 | | ns |

¹The $t_{DDTLFSE}$ and $t_{DDTENFS}$ parameters apply to left-justified sample pair mode as well as DSP serial mode, and MCE = 1, MFD = 0.

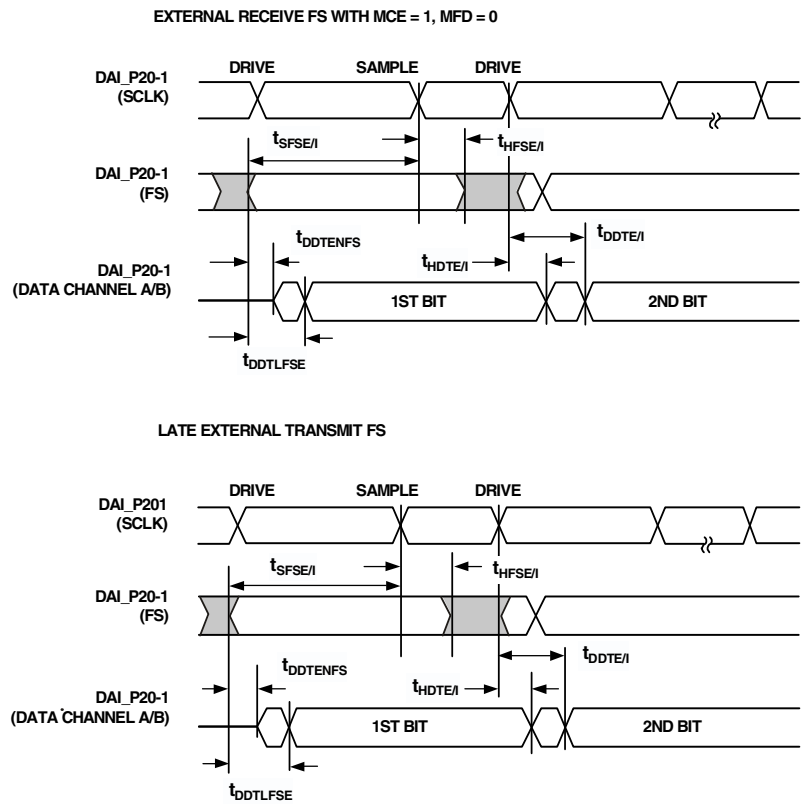

NOTE: SERIAL PORT SIGNALS (SCLK, FS, DATA CHANNEL A/B) ARE ROUTED TO THE DAI_P[20:1] PINS USING THE SRU. THE TIMING SPECIFICATIONS PROVIDED HERE ARE VALID AT THE DAI_P[20:1] PINS.

Figure 20. External Late Frame Sync¹

¹This figure reflects changes made to support left-justified sample pair mode.

ADSP-21261/ADSP-21262/ADSP-21266

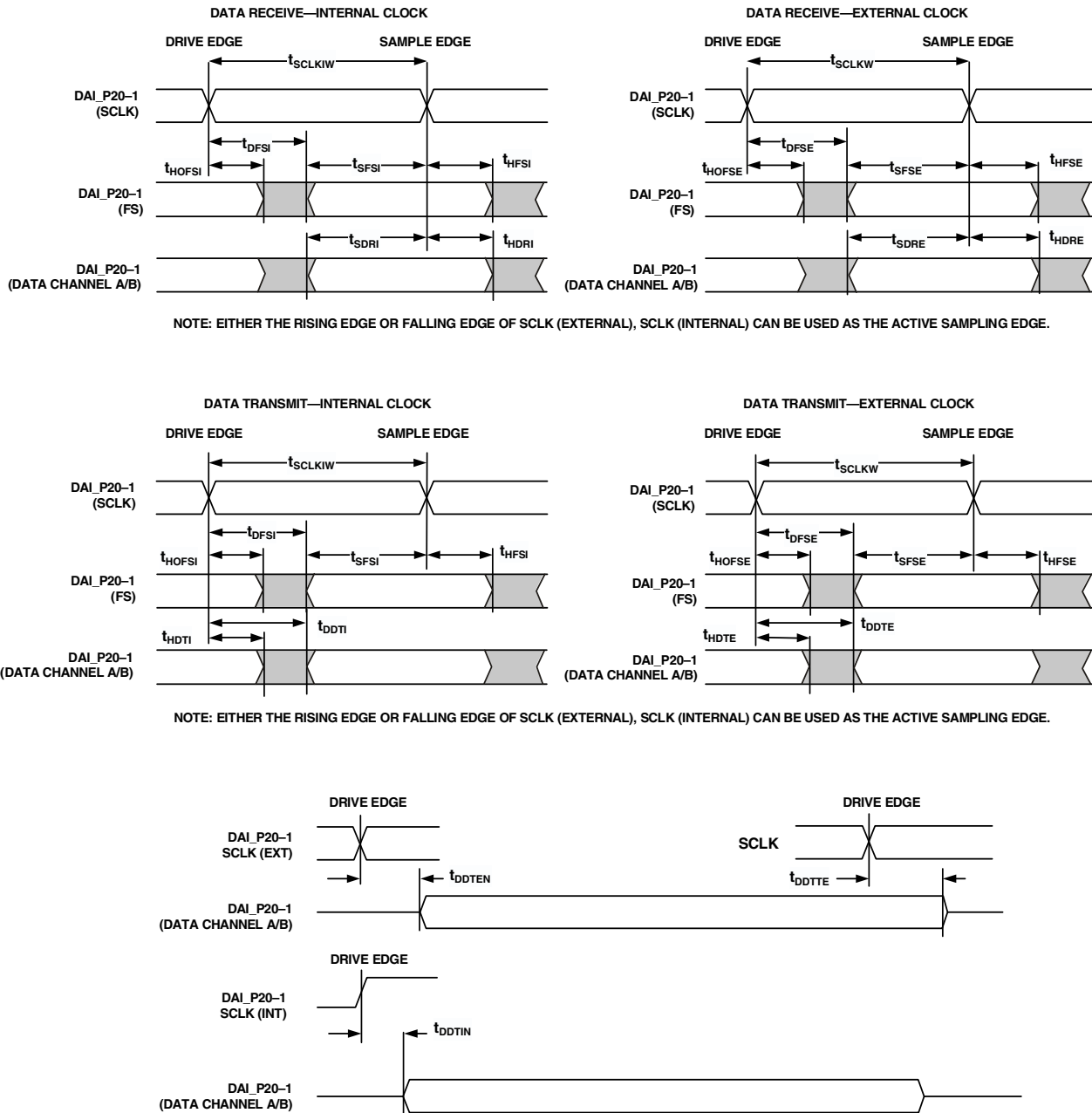

Figure 21. Serial Ports

Input Data Port (IDP)

The timing requirements for the IDP are given in [Table 33](#) and [Figure 22](#). IDP Signals (SCLK, FS, SDATA) are routed to the DAI_P20-1 pins using the SRU. Therefore, the timing specifications provided below are valid at the DAI_P20-1 pins.

Table 33. Input Data Port (IDP)

| Parameter | | Min | Max | Unit |
|----------------------------|--|-----|-----|------|
| <i>Timing Requirements</i> | | | | |
| t_{SISFS} | FS Setup Before SCLK Rising Edge ¹ | 2.5 | | ns |
| t_{SIHFS} | FS Hold After SCLK Rising Edge ¹ | 2.5 | | ns |
| t_{SISD} | SDATA Setup Before SCLK Rising Edge ¹ | 2.5 | | ns |
| t_{SIHD} | SDATA Hold After SCLK Rising Edge ¹ | 2.5 | | ns |
| $t_{IDPCLKW}$ | Clock Width | 7 | | ns |
| t_{IDPCLK} | Clock Period | 20 | | ns |

¹ DATA, SCLK, FS can come from any of the DAI pins. SCLK and FS can also come via the precision clock generators (PCG) or SPORTs. PCG input can be either CLKIN or any of the DAI pins.

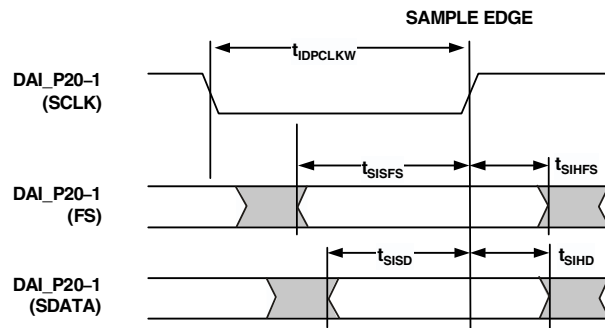

Figure 22. Input Data Port (IDP)

ADSP-21261/ADSP-21262/ADSP-21266

Parallel Data Acquisition Port (PDAP)

The timing requirements for the PDAP are provided in [Table 34](#) and [Figure 23](#). PDAP is the parallel mode operation of Channel 0 of the IDP. For details on the operation of the IDP, see the IDP chapter of the *ADSP-2126x Peripherals Manual*.

Note that the most significant 16 bits of external PDAP data can be provided through either the parallel port AD15–0 or the DAI_P20–5 pins. The remaining four bits can only be sourced through DAI_P4–1. The timing below is valid at the DAI_P20–1 pins or at the AD15–0 pins.

Table 34. Parallel Data Acquisition Port (PDAP)

| Parameter | Min | Max | Unit |
|--|-------------------------|-----|------|
| <i>Timing Requirements</i> | | | |
| t_{SPCKEN} PDAP_CLKEN Setup Before PDAP_CLK Sample Edge ¹ | 2.5 | | ns |
| t_{HPCKEN} PDAP_CLKEN Hold After PDAP_CLK Sample Edge ¹ | 2.5 | | ns |
| t_{PDS} PDAP_DAT Setup Before SCLK PDAP_CLK Sample Edge ¹ | 2.5 | | ns |
| t_{PDHD} PDAP_DAT Hold After SCLK PDAP_CLK Sample Edge ¹ | 2.5 | | ns |
| t_{PDCLKW} Clock Width | 7 | | ns |
| t_{PDCLK} Clock Period | 20 | | ns |
| <i>Switching Characteristics</i> | | | |
| t_{PDHDD} Delay of PDAP Strobe After Last PDAP_CLK Capture Edge for a Word | $2 \times t_{CCLK}$ | | ns |
| t_{PDSTRB} PDAP Strobe Pulse Width | $1 \times t_{CCLK} - 1$ | | ns |

¹ Source pins of DATA are ADDR7–0, DATA7–0, or DAI pins. Source pins for SCLK and FS are: 1) DAI pins, 2) CLKIN through PCG, or 3) DAI pins through PCG.

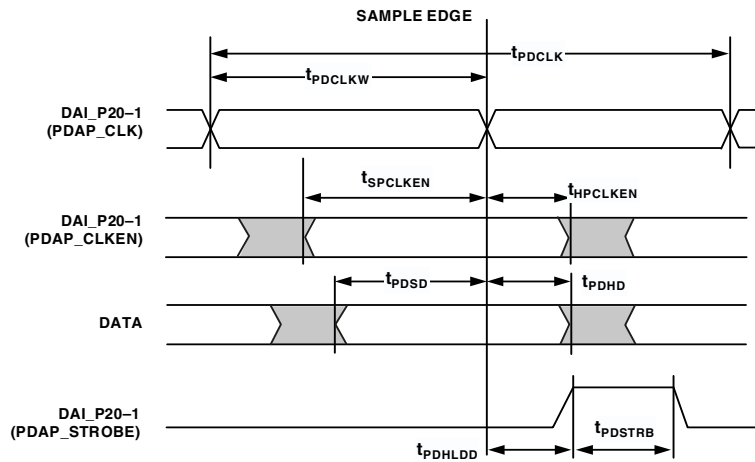

Figure 23. Parallel Data Acquisition Port (PDAP)

SPI Interface Protocol—Master

Table 35. SPI Interface Protocol—Master

| Parameter | | Min | Max | Unit |
|----------------------------------|--|-------------------------|-----|------|
| <i>Timing Requirements</i> | | | | |
| t_{SSPIDM} | Data Input Valid to SPICLK Edge (Data Input Setup Time) | 5 | | ns |
| t_{HSPIDM} | SPICLK Last Sampling Edge to Data Input Not Valid | 2 | | ns |
| <i>Switching Characteristics</i> | | | | |
| $t_{SPICLKM}$ | Serial Clock Cycle | $8 \times t_{CCLK}$ | | ns |
| t_{SPICHM} | Serial Clock High Period | $4 \times t_{CCLK} - 2$ | | ns |
| t_{SPICLM} | Serial Clock Low Period | $4 \times t_{CCLK} - 2$ | | ns |
| $t_{DDSPIDM}$ | SPICLK Edge to Data Out Valid (Data Out Delay Time) | | 3 | ns |
| $t_{HDSPIDM}$ | SPICLK Edge to Data Out Not Valid (Data Out Hold Time) | 10 | | ns |
| t_{SDSCIM} | FLAG3-0 OUT (SPI Device Select) Low to First SPICLK Edge | $4 \times t_{CCLK} - 2$ | | ns |
| t_{HDSM} | Last SPICLK Edge to FLAG3-0 OUT High | $4 \times t_{CCLK} - 1$ | | ns |
| t_{SPITDM} | Sequential Transfer Delay | $4 \times t_{CCLK} - 1$ | | ns |

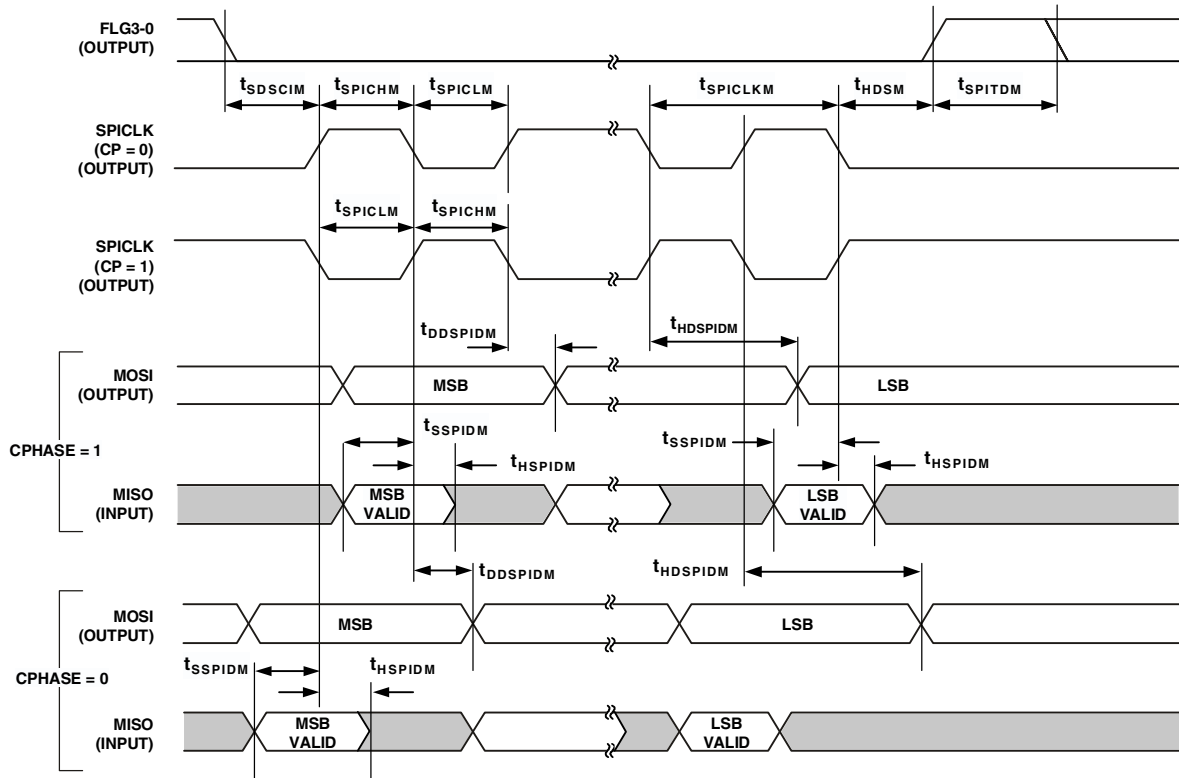

Figure 24. SPI Interface Protocol—Master

ADSP-21261/ADSP-21262/ADSP-21266

SPI Interface Protocol—Slave

Table 36. SPI Interface Protocol—Slave

| Parameter | | Min | Max | Unit |
|----------------------------------|--|-------------------------|-------------------------|------|
| <i>Timing Requirements</i> | | | | |
| $t_{SPICLKS}$ | Serial Clock Cycle | $4 \times t_{CCLK}$ | | ns |
| t_{SPICHS} | Serial Clock High Period | $2 \times t_{CCLK} - 2$ | | ns |
| t_{SPICLS} | Serial Clock Low Period | $2 \times t_{CCLK} - 2$ | | ns |
| t_{SDSCO} | \overline{SPIDS} Assertion to First SPICLK Edge | | | |
| | CPHASE = 0 | $2 \times t_{CCLK} + 1$ | | ns |
| | CPHASE = 1 | $2 \times t_{CCLK} + 1$ | | ns |
| t_{HDS} | Last SPICLK Edge to \overline{SPIDS} Not Asserted CPHASE = 0 | $2 \times t_{CCLK}$ | | ns |
| t_{SSPIDS} | Data Input Valid to SPICLK Edge (Data Input Setup Time) | 2 | | ns |
| t_{HSPIDS} | SPICLK Last Sampling Edge to Data Input Not Valid | 2 | | ns |
| t_{SDPPW} | \overline{SPIDS} Deassertion Pulse Width (CPHASE = 0) | $2 \times t_{CCLK}$ | | ns |
| <i>Switching Characteristics</i> | | | | |
| t_{DSOE} | \overline{SPIDS} Assertion to Data Out Active | 0 | 5 | ns |
| t_{DSDHI} | \overline{SPIDS} Deassertion to Data High Impedance | 0 | 5 | ns |
| $t_{DDSPIDS}$ | SPICLK Edge to Data Out Valid (Data Out Delay Time) | | 7.5 | ns |
| $t_{HDSPIOS}$ | SPICLK Edge to Data Out Not Valid (Data Out Hold Time) | $2 \times t_{CCLK} - 2$ | | ns |
| t_{DSOV} | \overline{SPIDS} Assertion to Data Out Valid (CPHASE = 0) | | $5 \times t_{CCLK} + 2$ | ns |

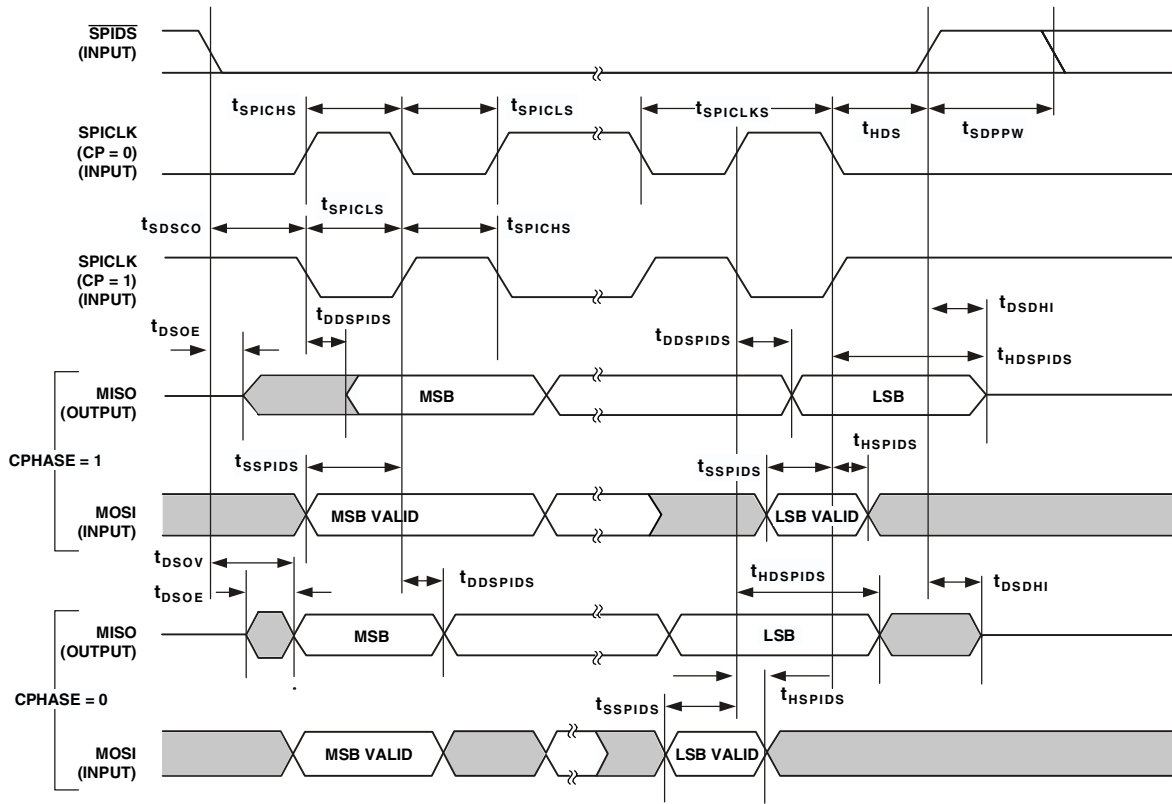

Figure 25. SPI Interface Protocol—Slave

JTAG Test Access Port and Emulation

Table 37. JTAG Test Access Port and Emulation

| Parameter | Min | Max | Unit |
|---|-------------------|-----|------|
| <i>Timing Requirements</i> | | | |
| t_{TCK} TCK Period | 20 | | ns |
| t_{STAP} TDI, TMS Setup Before TCK High | 5 | | ns |
| t_{HTAP} TDI, TMS Hold After TCK High | 6 | | ns |
| t_{SSYS} System Inputs Setup Before TCK High ¹ | 7 | | ns |
| t_{HSYS} System Inputs Hold After TCK High ¹ | 8 | | ns |
| t_{TRSTW} \overline{TRST} Pulse Width | $4 \times t_{CK}$ | | ns |
| <i>Switching Characteristics</i> | | | |
| t_{DTDO} TDO Delay from TCK Low | | 7 | ns |
| t_{DSYS} System Outputs Delay After TCK Low ² | | 10 | ns |

¹System Inputs = AD15-0, \overline{SPIDS} , CLK_CFG1-0, \overline{RESET} , $\overline{BOOT_CFG1-0}$, MISO, MOSI, SPICLK, DAI_Px, FLAG3-0.

²System Outputs = MISO, MOSI, SPICLK, DAI_Px, AD15-0, \overline{RD} , \overline{WR} , FLAG3-0, CLKOUT, \overline{EMU} , ALE.

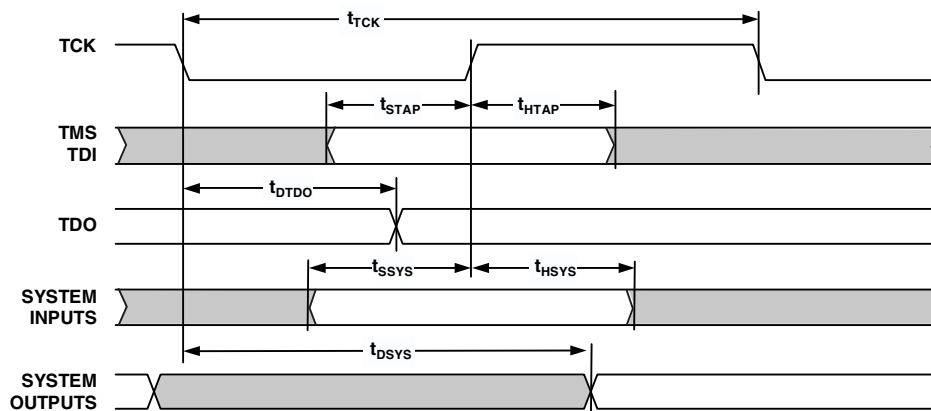

Figure 26. JTAG Test Access Port and Emulation

ADSP-21261/ADSP-21262/ADSP-21266

OUTPUT DRIVE CURRENTS

Figure 27 shows typical I-V characteristics for the output drivers of the ADSP-2126x. The curves represent the current drive capability of the output drivers as a function of output voltage.

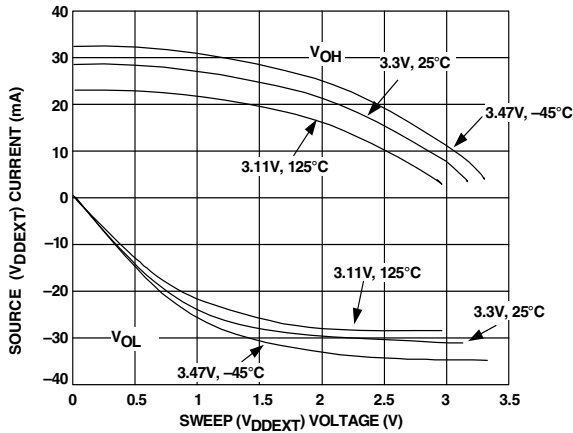

Figure 27. Typical Drive

TEST CONDITIONS

The ac signal specifications (timing parameters) appear in Table 16 on Page 18 through Table 37 on Page 35. These include output disable time, output enable time, and capacitive loading.

Timing is measured on signals when they cross the 1.5 V level as described in Figure 29. All delays (in nanoseconds) are measured between the point that the first signal reaches 1.5 V and the point that the second signal reaches 1.5 V.

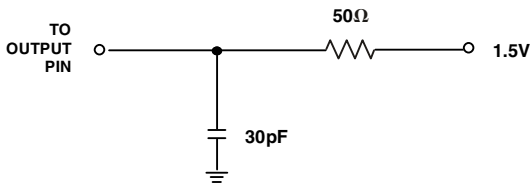

Figure 28. Equivalent Device Loading for AC Measurements (Includes All Fixtures)



Figure 29. Voltage Reference Levels for AC Measurements

CAPACITIVE LOADING

Output delays and holds are based on standard capacitive loads: 30 pF on all pins (see Figure 28). Figure 31 shows graphically how output delays and holds vary with load capacitance (note that this graph or derating does not apply to output disable delays). The graphs of Figure 30, Figure 31, and Figure 32 may not be linear outside the ranges shown for Typical Output Delay vs. Load Capacitance and Typical Output Rise Time (20% to 80%, V = Min) vs. Load Capacitance.

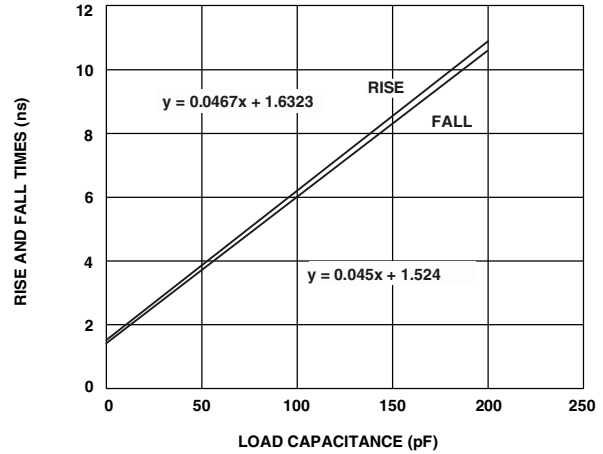

Figure 30. Typical Output Rise Time (20% to 80%, V_{DDEXT} = Max)

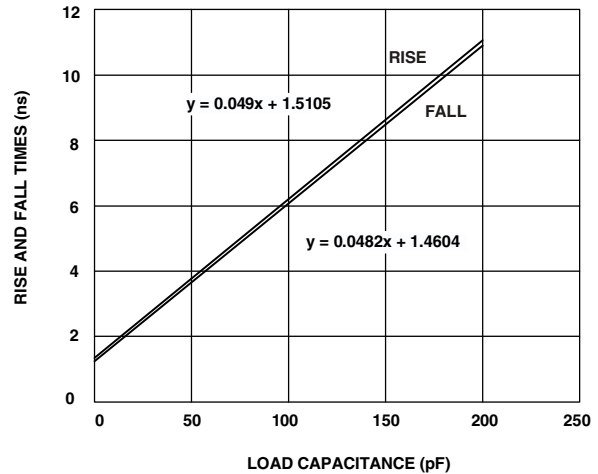

Figure 31. Typical Output Rise/Fall Time (20% to 80%, V_{DDEXT} = Min)

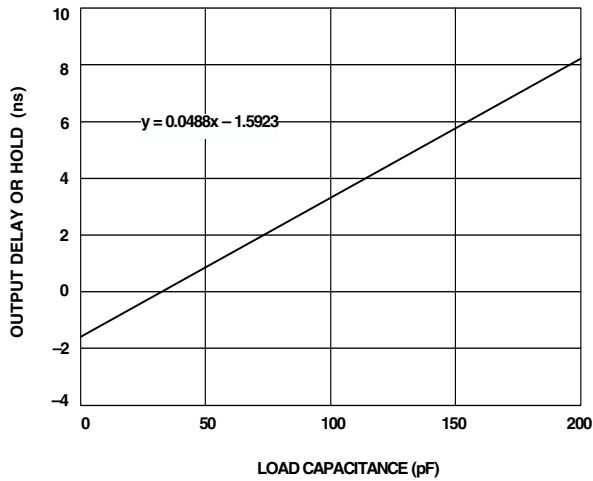

Figure 32. Typical Output Delay or Hold vs. Load Capacitance (at Ambient Temperature)

ENVIRONMENTAL CONDITIONS

The ADSP-2126x processor is rated for performance under T_{AMB} environmental conditions specified in the [Operating Conditions on Page 14](#).

THERMAL CHARACTERISTICS

[Table 38](#) and [Table 39](#) airflow measurements comply with JEDEC standards JESD51-2 and JESD51-6 and the junction-to-board measurement complies with JESD51-8. The junction-to-case measurement complies with MIL-STD-883. All measurements use a 2S2P JEDEC test board.

To determine the junction temperature of the device while on the application PCB, use

$$T_J = T_{CASE} + (\Psi_{JT} \times P_D)$$

where:

T_J = junction temperature (°C)

T_{CASE} = case temperature (°C) measured at the top center of the package

Ψ_{JT} = junction-to-top (of package) characterization parameter is the typical value from [Table 38](#) and [Table 39](#) (Ψ_{JMT} indicates moving air).

P_D = power dissipation. See *Estimating Power Dissipation for ADSP-21262 SHARC DSPs (EE-216)* for more information.

Values of θ_{JA} are provided for package comparison and PCB design considerations (θ_{JMA} indicates moving air). θ_{JA} can be used for a first order approximation of T_J by the equation

$$T_J = T_A + (\theta_{JA} \times P_D)$$

where:

T_A = ambient temperature °C

Values of θ_{JC} are provided for package comparison and PCB design considerations when an external heat sink is required.

Table 38. Thermal Characteristics for 136-Ball BGA

| Parameter | Condition | Typical | Unit |
|----------------|-----------------|---------|------|
| θ_{JA} | Airflow = 0 m/s | 31.0 | °C/W |
| θ_{JMA} | Airflow = 1 m/s | 27.3 | °C/W |
| θ_{JMA} | Airflow = 2 m/s | 26.0 | °C/W |
| θ_{JC} | | 6.99 | °C/W |
| Ψ_{JT} | Airflow = 0 m/s | 0.16 | °C/W |
| Ψ_{JMT} | Airflow = 1 m/s | 0.30 | °C/W |
| Ψ_{JMT} | Airflow = 2 m/s | 0.35 | °C/W |

Table 39. Thermal Characteristics for 144-Lead LQFP

| Parameter | Condition | Typical | Unit |
|----------------|-----------------|---------|------|
| θ_{JA} | Airflow = 0 m/s | 32.5 | °C/W |
| θ_{JMA} | Airflow = 1 m/s | 28.9 | °C/W |
| θ_{JMA} | Airflow = 2 m/s | 27.8 | °C/W |
| θ_{JC} | | 7.8 | °C/W |
| Ψ_{JT} | Airflow = 0 m/s | 0.5 | °C/W |
| Ψ_{JMT} | Airflow = 1 m/s | 0.8 | °C/W |
| Ψ_{JMT} | Airflow = 2 m/s | 1.0 | °C/W |

ADSP-21261/ADSP-21262/ADSP-21266

144-LEAD LQFP PIN CONFIGURATIONS

Table 40 shows the ADSP-2126x's pin names and their default function after reset (in parentheses).

Table 40. 144-Lead LQFP Pin Assignments

| Pin Name | LQFP Pin No. | Pin Name | LQFP Pin No. | Pin Name | LQFP Pin No. | Pin Name | LQFP Pin No. |
|------------------------|--------------|------------------------|--------------|--------------------|--------------|------------------------------|--------------|
| V _{DDINT} | 1 | V _{DDINT} | 37 | V _{DDEXT} | 73 | GND | 109 |
| CLK_CFG0 | 2 | GND | 38 | GND | 74 | V _{DDINT} | 110 |
| CLK_CFG1 | 3 | $\overline{\text{RD}}$ | 39 | V _{DDINT} | 75 | GND | 111 |
| BOOT_CFG0 | 4 | ALE | 40 | GND | 76 | V _{DDINT} | 112 |
| BOOT_CFG1 | 5 | AD15 | 41 | DAI_P10 (SD2B) | 77 | GND | 113 |
| GND | 6 | AD14 | 42 | DAI_P11 (SD3A) | 78 | V _{DDINT} | 114 |
| V _{DDEXT} | 7 | AD13 | 43 | DAI_P12 (SD3B) | 79 | GND | 115 |
| GND | 8 | GND | 44 | DAI_P13 (SCLK23) | 80 | V _{DDEXT} | 116 |
| V _{DDINT} | 9 | V _{DDEXT} | 45 | DAI_P14 (SFS23) | 81 | GND | 117 |
| GND | 10 | AD12 | 46 | DAI_P15 (SD4A) | 82 | V _{DDINT} | 118 |
| V _{DDINT} | 11 | V _{DDINT} | 47 | V _{DDINT} | 83 | GND | 119 |
| GND | 12 | GND | 48 | GND | 84 | V _{DDINT} | 120 |
| V _{DDINT} | 13 | AD11 | 49 | GND | 85 | $\overline{\text{RESET}}$ | 121 |
| GND | 14 | AD10 | 50 | DAI_P16 (SD4B) | 86 | $\overline{\text{SPIDS}}$ | 122 |
| FLAG0 | 15 | AD9 | 51 | DAI_P17 (SD5A) | 87 | GND | 123 |
| FLAG1 | 16 | AD8 | 52 | DAI_P18 (SD5B) | 88 | V _{DDINT} | 124 |
| AD7 | 17 | DAI_P1 (SD0A) | 53 | DAI_P19 (SCLK45) | 89 | SPICLK | 125 |
| GND | 18 | V _{DDINT} | 54 | V _{DDINT} | 90 | MISO | 126 |
| V _{DDINT} | 19 | GND | 55 | GND | 91 | MOSI | 127 |
| GND | 20 | DAI_P2 (SD0B) | 56 | GND | 92 | GND | 128 |
| V _{DDEXT} | 21 | DAI_P3 (SCLK0) | 57 | V _{DDEXT} | 93 | V _{DDINT} | 129 |
| GND | 22 | GND | 58 | DAI_P20 (SFS45) | 94 | V _{DDEXT} | 130 |
| V _{DDINT} | 23 | V _{DDEXT} | 59 | GND | 95 | A _{VDD} | 131 |
| AD6 | 24 | V _{DDINT} | 60 | V _{DDINT} | 96 | A _{VSS} | 132 |
| AD5 | 25 | GND | 61 | FLAG2 | 97 | GND | 133 |
| AD4 | 26 | DAI_P4 (SFS0) | 62 | FLAG3 | 98 | $\overline{\text{RESETOUT}}$ | 134 |
| V _{DDINT} | 27 | DAI_P5 (SD1A) | 63 | V _{DDINT} | 99 | $\overline{\text{EMU}}$ | 135 |
| GND | 28 | DAI_P6 (SD1B) | 64 | GND | 100 | TDO | 136 |
| AD3 | 29 | DAI_P7 (SCLK1) | 65 | V _{DDINT} | 101 | TDI | 137 |
| AD2 | 30 | V _{DDINT} | 66 | GND | 102 | $\overline{\text{TRST}}$ | 138 |
| V _{DDEXT} | 31 | GND | 67 | V _{DDINT} | 103 | TCK | 139 |
| GND | 32 | V _{DDINT} | 68 | GND | 104 | TMS | 140 |
| AD1 | 33 | GND | 69 | V _{DDINT} | 105 | GND | 141 |
| AD0 | 34 | DAI_P8 (SFS1) | 70 | GND | 106 | CLKIN | 142 |
| $\overline{\text{WR}}$ | 35 | DAI_P9 (SD2A) | 71 | V _{DDINT} | 107 | XTAL | 143 |
| V _{DDINT} | 36 | V _{DDINT} | 72 | V _{DDINT} | 108 | V _{DDEXT} | 144 |

136-BALL BGA PIN CONFIGURATIONS

Table 41 shows the ADSP-2126x's pin names and their default function after reset (in parentheses). Figure 33 on Page 41 shows the BGA package pin assignments.

Table 41. 136-Ball BGA Pin Assignments

| Pin Name | BGA Pin No. | Pin Name | BGA Pin No. | Pin Name | BGA Pin No. | Pin Name | BGA Pin No. |
|------------------------------|-------------|---------------------------|-------------|--------------------|-------------|--------------------|-------------|
| CLK_CFG0 | A01 | CLK_CFG1 | B01 | BOOT_CFG1 | C01 | V _{DDINT} | D01 |
| XTAL | A02 | GND | B02 | BOOT_CFG0 | C02 | GND | D02 |
| TMS | A03 | V _{DDEXT} | B03 | GND | C03 | GND | D04 |
| TCK | A04 | CLKIN | B04 | GND | C12 | GND | D05 |
| TDI | A05 | $\overline{\text{TRST}}$ | B05 | GND | C13 | GND | D06 |
| $\overline{\text{RESETOUT}}$ | A06 | A _{VSS} | B06 | V _{DDINT} | C14 | GND | D09 |
| TDO | A07 | A _{VDD} | B07 | | | GND | D10 |
| $\overline{\text{EMU}}$ | A08 | V _{DDEXT} | B08 | | | GND | D11 |
| MOSI | A09 | SPICLK | B09 | | | GND | D13 |
| MISO | A10 | $\overline{\text{RESET}}$ | B10 | | | V _{DDINT} | D14 |
| $\overline{\text{SPIDS}}$ | A11 | V _{DDINT} | B11 | | | | |
| V _{DDINT} | A12 | GND | B12 | | | | |
| GND | A13 | GND | B13 | | | | |
| GND | A14 | GND | B14 | | | | |
| V _{DDINT} | E01 | FLAG1 | F01 | AD7 | G01 | AD6 | H01 |
| GND | E02 | FLAG0 | F02 | V _{DDINT} | G02 | V _{DDEXT} | H02 |
| GND | E04 | GND | F04 | V _{DDEXT} | G13 | DAI_P18 (SD5B) | H13 |
| GND | E05 | GND | F05 | DAI_P19 (SCLK45) | G14 | DAI_P17 (SD5A) | H14 |
| GND | E06 | GND | F06 | | | | |
| GND | E09 | GND | F09 | | | | |
| GND | E10 | GND | F10 | | | | |
| GND | E11 | GND | F11 | | | | |
| GND | E13 | FLAG2 | F13 | | | | |
| FLAG3 | E14 | DAI_P20 (SFS45) | F14 | | | | |

ADSP-21261/ADSP-21262/ADSP-21266

Table 41. 136-Ball BGA Pin Assignments (Continued)

| Pin Name | BGA Pin No. | Pin Name | BGA Pin No. | Pin Name | BGA Pin No. | Pin Name | BGA Pin No. |
|------------------------|-------------|--------------------|-------------|-----------------|-------------|------------------------|-------------|
| AD5 | J01 | AD3 | K01 | AD2 | L01 | AD0 | M01 |
| AD4 | J02 | V _{DDINT} | K02 | AD1 | L02 | $\overline{\text{WR}}$ | M02 |
| GND | J04 | GND | K04 | GND | L04 | GND | M03 |
| GND | J05 | GND | K05 | GND | L05 | GND | M12 |
| GND | J06 | GND | K06 | GND | L06 | DAI_P12 (SD3B) | M13 |
| GND | J09 | GND | K09 | GND | L09 | DAI_P13 (SCLK23) | M14 |
| GND | J10 | GND | K10 | GND | L10 | | |
| GND | J11 | GND | K11 | GND | L11 | | |
| V _{DDINT} | J13 | GND | K13 | GND | L13 | | |
| DAI_P16 (SD4B) | J14 | DAI_P15 (SD4A) | K14 | DAI_P14 (SFS23) | L14 | | |
| AD15 | N01 | AD14 | P01 | | | | |
| ALE | N02 | AD13 | P02 | | | | |
| $\overline{\text{RD}}$ | N03 | AD12 | P03 | | | | |
| V _{DDINT} | N04 | AD11 | P04 | | | | |
| V _{DDEXT} | N05 | AD10 | P05 | | | | |
| AD8 | N06 | AD9 | P06 | | | | |
| V _{DDINT} | N07 | DAI_P1 (SD0A) | P07 | | | | |
| DAI_P2 (SD0B) | N08 | DAI_P3 (SCLK0) | P08 | | | | |
| V _{DDEXT} | N09 | DAI_P5 (SD1A) | P09 | | | | |
| DAI_P4 (SFS0) | N10 | DAI_P6 (SD1B) | P10 | | | | |
| V _{DDINT} | N11 | DAI_P7 (SCLK1) | P11 | | | | |
| V _{DDINT} | N12 | DAI_P8 (SFS1) | P12 | | | | |
| GND | N13 | DAI_P9 (SD2A) | P13 | | | | |
| DAI_P10 (SD2B) | N14 | DAI_P11 (SD3A) | P14 | | | | |

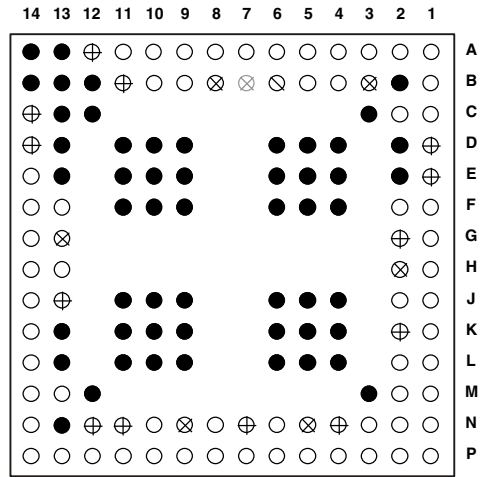

KEY

| | | |
|-------------|-----------|-------------|
| ⊕ | ● | ⊗ |
| V_{DDINT} | GND* | A_{VDD} |
| ⊗ | / | ○ |
| V_{DDEXT} | A_{VSS} | I/O SIGNALS |

*USE THE CENTER BLOCK OF GROUND PINS TO PROVIDE
THERMAL PATHWAYS TO YOUR PRINTED
CIRCUIT BOARD'S GROUND PLANE.

Figure 33. 136-Ball BGA Pin Assignments (Bottom View, Summary)

ADSP-21261/ADSP-21262/ADSP-21266

OUTLINE DIMENSIONS

The ADSP-2126x is available in a 136-ball BGA package and a 144-lead LQFP package shown in [Figure 35](#) and [Figure 34](#).

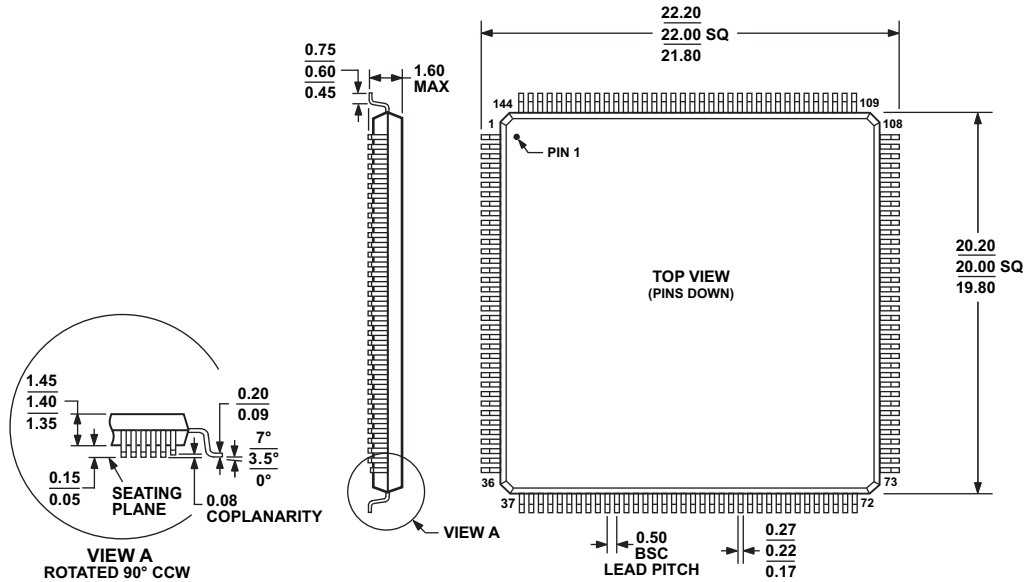

COMPLIANT TO JEDEC STANDARDS MS-026-BFB

Figure 34. 144-Lead Low Profile Flat Package [LQFP]
(ST-144)

Dimensions shown in millimeters

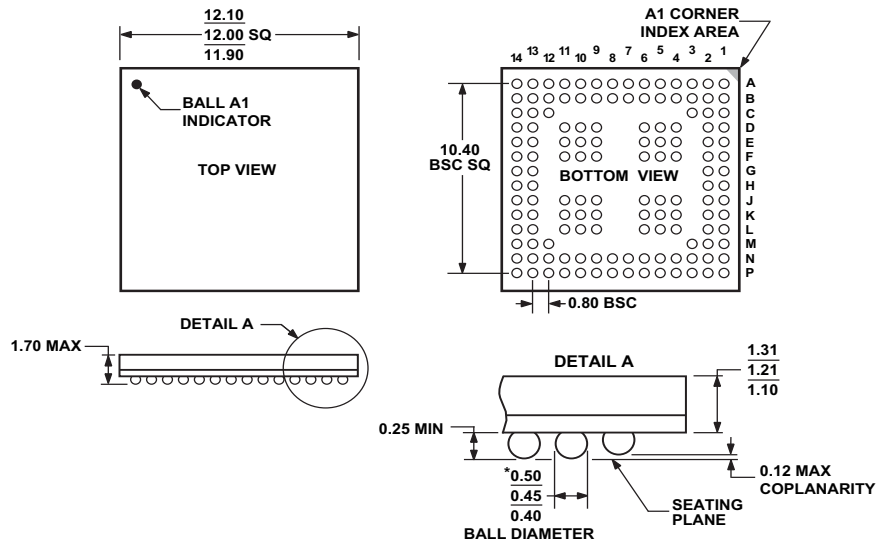

*COMPLIANT WITH JEDEC STANDARDS MO-205-AE WITH EXCEPTION TO BALL DIAMETER.

Figure 35. 136-Ball Chip Scale Package Ball Grid Array [CSP_BGA] (BC-136)

Dimensions shown in millimeters

SURFACE-MOUNT DESIGN

Table 42 is provided as an aide to PCB design. For industry-standard design recommendations, refer to IPC-7351, *Generic Requirements for Surface-Mount Design and Land Pattern Standard*.

Table 42. BGA_ED Data for Use with Surface-Mount Design

| Package | Ball Attach Type | Solder Mask Opening | Ball Pad Size |
|---------------------------|---------------------------|---------------------|---------------|
| 136-Ball CSP_BGA (BC-136) | Solder Mask Defined (SMD) | 0.4 mm | 0.53 mm |

ADSP-21261/ADSP-21262/ADSP-21266

AUTOMOTIVE PRODUCTS

The ADSP-21261W and ADSP-21262W are available for automotive applications with controlled manufacturing. Note that these special models may have specifications that differ from the general release models. Contact your local ADI account

representative or authorized ADI product distributor for specific product ordering information. Note that all automotive products are RoHS compliant.

ORDERING GUIDE

Analog Devices offers a wide variety of audio algorithms and combinations to run on the ADSP-21266 DSP. For a complete list, visit our website at www.analog.com/SHARC.

| Model | Temperature Range ¹ | Instruction Rate | On-Chip SRAM | ROM | Package Description | Package Option |
|-----------------------------------|--------------------------------|------------------|--------------|--------|---------------------|----------------|
| ADSP-21261SKBC-150 | 0°C to +70°C | 150 MHz | 1M bit | 3M bit | 136-Ball CSP_BGA | BC-136 |
| ADSP-21261SKBCZ150 ² | 0°C to +70°C | 150 MHz | 1M bit | 3M bit | 136-Ball CSP_BGA | BC-136 |
| ADSP-21261SKSTZ150 ² | 0°C to +70°C | 150 MHz | 1M bit | 3M bit | 144-Lead LQFP | ST-144 |
| ADSP-21262SBBC-150 | -40°C to +85°C | 150 MHz | 2M bit | 4M bit | 136-Ball CSP_BGA | BC-136 |
| ADSP-21262SBBCZ150 ² | -40°C to +85°C | 150 MHz | 2M bit | 4M bit | 136-Ball CSP_BGA | BC-136 |
| ADSP-21262SKBC-200 | 0°C to +70°C | 200 MHz | 2M bit | 4M bit | 136-Ball CSP_BGA | BC-136 |
| ADSP-21262SKBCZ200 ² | 0°C to +70°C | 200 MHz | 2M bit | 4M bit | 136-Ball CSP_BGA | BC-136 |
| ADSP-21262SKSTZ200 ² | 0°C to +70°C | 200 MHz | 2M bit | 4M bit | 144-Lead LQFP | ST-144 |
| ADSP-21266SKSTZ-1B ^{2,3} | 0°C to +70°C | 150 MHz | 2M bit | 4M bit | 144-Lead LQFP | ST-144 |
| ADSP-21266SKSTZ-2B ^{2,3} | 0°C to +70°C | 200 MHz | 2M bit | 4M bit | 144-Lead LQFP | ST-144 |
| ADSP-21266SKBCZ-2B ^{2,3} | 0°C to +70°C | 200 MHz | 2M bit | 4M bit | 136-Ball CSP_BGA | BC-136 |
| ADSP-21266SKSTZ-1C ^{2,4} | 0°C to +70°C | 150 MHz | 2M bit | 4M bit | 144-Lead LQFP | ST-144 |
| ADSP-21266SKSTZ-2C ^{2,4} | 0°C to +70°C | 200 MHz | 2M bit | 4M bit | 144-Lead LQFP | ST-144 |
| ADSP-21266SKBCZ-2C ^{2,4} | 0°C to +70°C | 200 MHz | 2M bit | 4M bit | 136-Ball CSP_BGA | BC-136 |
| ADSP-21266SKSTZ-1D ^{2,4} | 0°C to +70°C | 150 MHz | 2M bit | 4M bit | 144-Lead LQFP | ST-144 |
| ADSP-21266SKSTZ-2D ^{2,4} | 0°C to +70°C | 200 MHz | 2M bit | 4M bit | 144-Lead LQFP | ST-144 |
| ADSP-21266SKBCZ-2D ^{2,4} | 0°C to +70°C | 200 MHz | 2M bit | 4M bit | 136-Ball CSP_BGA | BC-136 |

¹Referenced temperature is ambient temperature.

²Z = RoHS Compliant Part.

³B at end of part number indicates Rev. 0.1 silicon. See Table 3 on Page 4 for multichannel surround sound decoder algorithms in on-chip B ROM.

⁴C and D at end of part number indicate Rev. 0.2 silicon. See Table 3 on Page 4 for multichannel surround sound decoder algorithms in on-chip C and D ROM.