

## TABLE OF CONTENTS

### HAND-HELD TOOLS

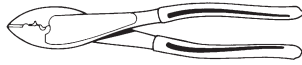

Y10D.....	N-3
Y10-22.....	N-4
Y8MRB-1.....	N-5
MR8 & MR10.....	N-6
MR15, MR18 & MR20.....	N-7
MR4C.....	N-8
Y1MRTC.....	N-9
M8ND.....	N-10

### MECHANICAL TOOLS

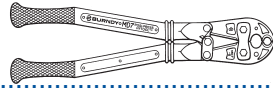

MRC840.....	N-11
MY29 & MY28.....	N-12
OH25.....	N-13
OUR840.....	N-14
MD6, MD6-4, MD6-6, MD6-12, MD6-14, MD6-37 & MD6-38.....	N-15
MD7, MD7-6 & MD7-8.....	N-16
MD7-34R.....	N-17
MD6/MD7 Accessories.....	N-18
MD6R.....	N-19
MD6 Hotstick Tools.....	N-20

### SELF-CONTAINED HYDRAULIC



Y500CT-HS.....	N-21
Y35 & Y35-2.....	N-22
Y35 Accessories.....	N-23
Y39.....	N-24
Y750HS & Y750-2HS.....	N-25
Y644HS.....	N-26
Y81KFT.....	N-27
YCUT129ACSR.....	N-28

### BATTERY ACTUATED TOOLS

PAT750XT-18V.....	N-29
PAT644-18V.....	N-30
PAT81KFT-18V.....	N-31
PATMD6-18V.....	N-32
PAT600-18V.....	N-33
PATCUT129ACSR-18V.....	N-34
PATCUT245CUAL-18V.....	N-35
BCC1000CUAL.....	N-36
Y700DC-1B.....	N-37

### REMOTE HYDRAULIC

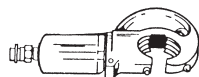

Y35BH (10000 Psi).....	N-38
Y39BH (10000 Psi).....	N-39
Y34BH (10000 Psi).....	N-40

Y29BH (6000 Psi).....	N-41
Y750BH (10000 Psi).....	N-42
LPHY750 (KOMPRESSOR™).....	N-43
LPHY46 (KOMPRESSOR™).....	N-44
Y644MBH.....	N-45
Y81KFTMBH.....	N-46
Y45 (10000 Psi).....	N-47
Y46 & Y46C (10000 Psi).....	N-48
Y48BH (8800 Psi).....	N-49
Y60BHU & Y60BHU-D.....	N-50
RHCC129ACSR.....	N-51
RHCC245CUAL.....	N-52
MCC500 & MCC1000.....	N-53
RCC556 & RCC1000.....	N-54

### HYDRAULIC PUMPS HAND PUMPS

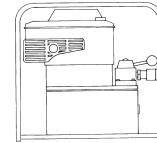

HP10 (10000 Psi).....	N-55
HP8 (8800 Psi).....	N-55
HP6 (6000 Psi).....	N-55

### FOOT PUMPS

FP10 (10000 Psi).....	N-56
FP8 (8800 Psi).....	N-56
FP6 (6000 Psi).....	N-56

### ELECTRIC PUMPS

EPP10 & EPP6.....	N-57
EPAC10, EPAC8 & EPAC6.....	N-58
EP10, EP8, EP6, EP10-2, EP8-2 & EP6-2.....	N-59
EP10-1HP, EP8-1HP, EP6-1HP, EP10-1HP-2, EP8-1HP-2 & EP6-1HP-2.....	N-60

### GASOLINE PUMPS

GP10 (10000 Psi).....	N-61
GP8 (8800 Psi).....	N-61
GP6 (6000 Psi).....	N-61



Hydraulic Hoses.....	N-62
----------------------	------

Accessories.....	N-63
------------------	------

RK147-2 & Wire Mike.....	N-64
--------------------------	------

Y29NC Pneumatic HYPRESS™.....	N-65
-------------------------------	------

TFM Tape Fed Machine.....	N-66
---------------------------	------

TFM Installation Tooling Chart.....	N-67
-------------------------------------	------

## INTRODUCTION

### INSTALLATION TOOLS

FCI Electrical's total compression program offers the most complete line of installation tools, mechanical, full cycle ratchet, self contained hydraulic, remote controlled hydraulic, power actuated pumps, hoses and accessories, available to the electrical industry. These tools have been designed to integrate with the complete line of BURNDY® compression connectors. Whether you're a small contractor working with #22 wire or a large utility working with 2500 kcmil conductor, there's a BURNDY® compression tool available to do the job.

The benefits of compression are many, however, probably the most significant benefit is reliability. There's nothing more important to the electrical industry today than reliability. It represents the one area that leads to economical installations that will endure for the life of the installation.

### TOOL CENTER

An important element of the BURNDY® compression program is the Tool Center, 150 Burndy Road, Littleton, NH 03561 (800-426-8720). This center provides advice and information on the operation, maintenance and repair of BURNDY® tools. The repair center is staffed with specialized technicians who provide the best possible tool repair service, for all BURNDY® tools, pumps and accessories.

We designed and produced the first self contained hydraulic compression electrical connector installation tool in 1934. In our continuing efforts to provide the highest quality and highest value connection systems, we offer the current BURNDY® tool policy.

### LIMITED WARRANTY

The full line of FCI BURNDY Products® tools are warranted to be free of defects in materials and workmanship for a period of five (5) years from the date of shipment. If inspection by a certified tool technician shows the trouble is caused by defective workmanship or material, BURNDY will repair (or at our option), replace the tool.

### This Warranty does not apply where:

- Repairs or alterations have been made or attempted by others.
- Repairs are required because of normal wear and tear.
- The tool has been abused, misused or improperly maintained.
- The use of any non-BURNDY® products has resulted in damage to the tool.

### STANDARD LIMITED WARRANTY AND LIMITATION OF LIABILITY

FCI BURNDY Products® warrants that the goods and services stated on the face hereof, when furnished to Buyer by FCI, conform with FCI's current written specifications and drawings (or with those of the Buyer specifically accepted by FCI in writing), and will be free of defects in materials and workmanship. FCI's sole obligation (and Buyer's sole and exclusive remedy) for any breach of warranty under the foregoing warranty shall be to repair (at location designated by FCI) or, at FCI's option: To replace FOB the original point of delivery any goods which are non-conforming or defective and are so specified by buyer in a written certified mail notice to an officer of FCI within the applicable warranty period. FCI expressly disclaims any and all express or implied warranties other than the warranty of its title to goods and the warranty hereinabove set forth. Such disclaimer includes, without limitation, warranty of fitness for a particular purpose and warranty of merchantable quality.

**Limitation of Liability**—FCI will not, under any circumstances, be liable for the cost of removal or reinstallation of goods or the cost of disassembly or reassembly of equipment in connection therewith, or for loss of the use of Buyer's equipment or facilities, or for loss of business or good will or profits, or for cost of inspection or storage, or for any incidental or consequential damages of any nature or description whatever which may arise from FCI's sale of goods to Buyer.

### REPAIR POLICY

All non-warranty repaired tools are completely reconditioned and receive a limited 1-year warranty. Non-warranty repair returns tools to like new condition at a maximum cost of 40% of a new tool. A nominal service charge of \$5.00 is applied to all repairs to cover shop supplies, oil disposal and other miscellaneous services not covered as part of the standard repair.

If the decision is made not to repair, a handling charge of \$25.00 will be applied plus return freight costs.

### RETURN PROCEDURE

All tools sent to the Burndy Tool Center or an authorized repair center must be accompanied by a purchase order with detailed bill to and ship to address authorizing repair. Requests for repair charges before work is done must be stated on the purchase order. All tools sent to the Burndy Tool Center or an authorized repair center as a warranty claim must be accompanied by a proof of purchase such as a BURNDY® invoice or invoice from any BURNDY® distributor.

All tools must be shipped at the owner's expense, prepaid. BURNDY pays for the return freight, same surface freight as received. Airfreight returns will be returned same way collect for non-warranty repair and prepaid for warranty repairs.

This warranty and repair policy supercedes all previous policies and is in effect January 1, 2005.

### TYPE Y10D

#### HYTOOL™

**TWO TOOLS IN ONE**  
**#22-10 AWG NYLON**  
**INSULATED CONNECTORS**  
**#22-10 AWG UNINSULATED**  
**CONNECTORS**

Hand-held plier type tool that will install #10-22 AWG nylon insulated and uninsulated terminals and splices, with a precision machined wire cutter for aluminum and copper wire in the nose of the tool. Long handles provide greater mechanical advantage. 5-year limited warranty. Also available in convenience package as catalog number **RK195-2**.

#### BENEFITS

- Easy wire cutting with precision machined cutting blade.
- Save time, money and lower installed costs with one tool for both nylon insulated and uninsulated (bare) connectors.
- Easy tool operation out of the carton. No need to break in the tool prior to actual usage.
- A heavy duty forged steel tool, that has a rust resistant finish will provide a long durable life.



#### BENEFITS (CONTINUED)

- Easier crimping on #22-10 bare and nylon insulated connectors because of the longer handles that provides greater mechanical advantage.\*
- Comfort grip handles fit hands comfortably helping make the tool easy to use.
- Terminals and splice connectors are UL listed and CSA certified when installed with the Y10D HYTOOL™.
- 5-year limited warranty.

\* Conductor crimp only.

#### SPECIFICATIONS

Length: 9-3/4"  
 Weight: 13.5 oz.

#### FOR USE ON

##### BOX CAT. TYPES      BULK CAT. TYPES

##### #10-22 AWG nylon insulated terminals

TN	YAES
TN-F	YAES-E
YAE-N BOX	YAE-N
YAE-N-F BOX	YAE-N-F
YAE-Z BOX	YAE-Z
YAEV BOX	YAEV

##### #10-22 AWG nylon insulated splices

SN	YSE-HN *
SNM	YSES
YSE-H BOX *	YSE-H *

##### #10-22 AWG uninsulated (bare) terminals.

T	YAD
T-F	YAD-F
YAV BOX	YAV
YAV-T-F BOX	YAV-T-F
YAV-H BOX *	YAV-H *
YAV-H-F BOX *	YAV-H-F *
YAV-Z BOX	YAV-Z

##### #10-22 AWG uninsulated (bare) splices

YSV BOX	YSV
YSV-H BOX *	YSV-H *

#### Features

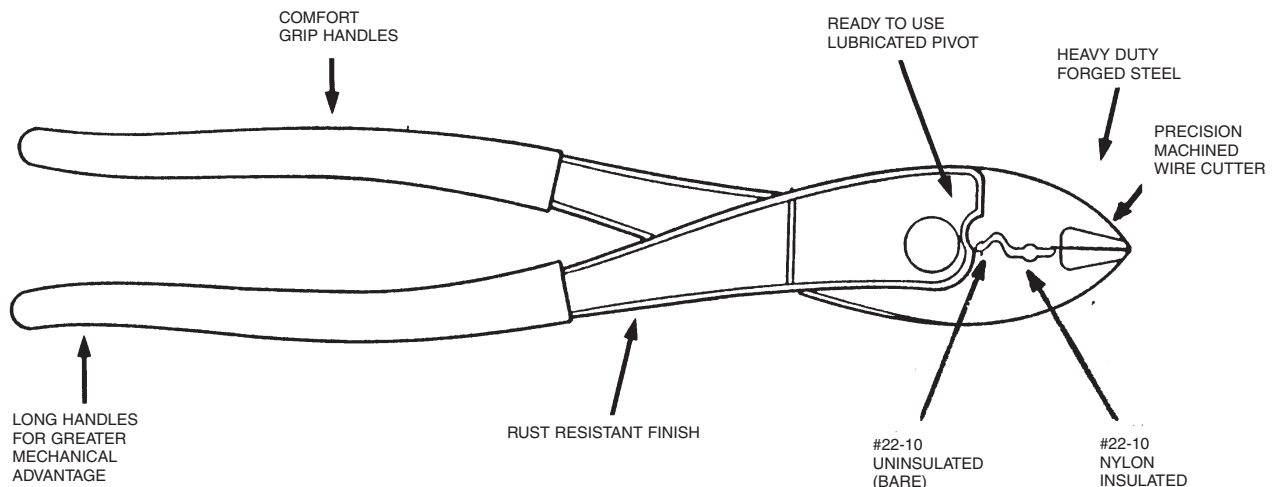

### TYPE Y10-22

#### HYTOOL™

#22-10 AWG INSULATED CONNECTORS  
#22-10 AWG UNINSULATED CONNECTORS

Hand-held plier type tool to install #10-22 AWG insulated and uninsulated terminals and splices with a wire cutter in the nose of the tool. Will strip #10-22 AWG wire and cut common size mild steel and non-ferrous screws. 5-year limited warranty. Also available in convenience package as **RK102-2**.



#### BENEFITS

- Easy wire cutting with anvil type wire cutter design.
- Crimps full range of insulated terminals and splices #22-10 AWG.
- Cut off dies for common size mild steel and non-ferrous screws.
- Crimps full range of uninsulated terminals and splices #22-10 AWG.
- Full range insulation strippers for wire sizes #22-10. One step stripping.
- Comfort grip handles fit hands comfortably helping make the tool easy to use.
- 5-year limited warranty.

\* Conductor crimp only.

#### SPECIFICATIONS

Length: 8-5/8"  
Weight: 11 oz.

#### FOR USE ON

##### BOX CAT. TYPES BULK CAT. TYPES

##### #10-22 AWG NYLON INSULATED TERMINALS

TN	YAES
TN-F	YAES-F
YAE-N BOX	YAE-N
YAE-N-F BOX	YAE-N-F
YAE-Z BOX	YAE-Z
YAEV BOX	YAEV

##### #10-22 AWG NYLON INSULATED SPLICES

SN	YSE-HN *
SNM	YSES
YSE-H BOX	*YSE-H *

##### #10-22 AWG VINYL INSULATED TERMINALS

TP	BA
TP-F	BA-EF
TP-ZBA-EZ	

##### #10-22 AWG VINYL INSULATED SPLICES

SP	BS
----	----

##### #10-22 AWG UNINSULATED (BARE) TERMINALS

T	YAD
T-F	YAD-F
YAV BOX	YAV
YAV-T-F BOX	YAV-T-F
YAV-H-F BOX *	YAV-H-F *
YAV-Z BOX	YAV-Z

##### #10-22 AWG UNINSULATED (BARE) SPLICES

YSV BOX	YSV
YSV-H BOX *	YSV-H *

#### Features

WIRE CUTTERS

ONE STEP INDIVIDUALLY SIZED WIRE STRIPPERS

SCREW AND BOLT CUTTERS

#12-10 INSULATED COLOR CODE YELLOW

WIRE CUTTER

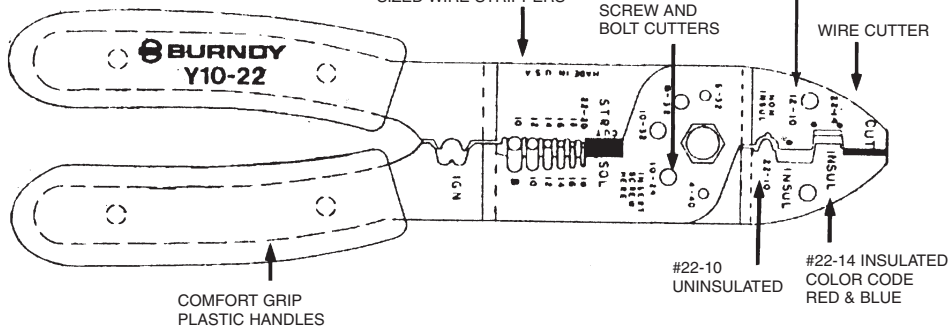

COMFORT GRIP PLASTIC HANDLES

### TYPE Y8MRB-1

#### HYTOOL™

#22-8 AWG

Hand-held full cycle ratchet tool for #8-22 AWG uninsulated terminals and splices. Full cycle feature builds in reliability and removes the human factor from the finished installation. 5-year limited warranty.

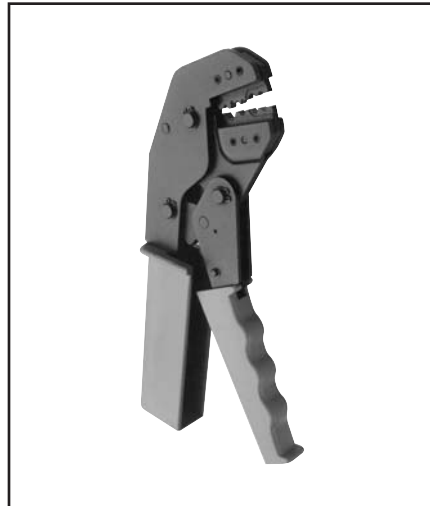

#### SPECIFICATIONS

Length: 9-1/2"  
Weight: 1.21 lbs.

#### FOR USE ON

**BOX CAT. TYPES    BULK CAT. TYPES**

#### UNINSULATED TERMINALS

T	YAD
T-F	YAD-F
YAV BOX	YAV
YAV-L BOX	YAV-L
YAV-T-F BOX	YAV-T-F
YAV-Z BOX	YAV-Z

#### UNINSULATED SPLICES

YSV BOX	YSV
YSV-L BOX	YSV-L

#### BENEFITS

- One tool to accommodate #22-8 AWG.
- Lightweight.
- Full cycle ratchet for positive crimping.
- Inspection (PG) gauges available to check each groove.

#### Groove    Gauge#

#18	PG395-1
#14	PG396-1
#10	PG397-1
# 8	PG398-1

- Each indenter has its own identifying mark for inspectability.
- Jaw opening orientation, molded finger and palm grips and the easy reach frame minimize user fatigue.

#### Features

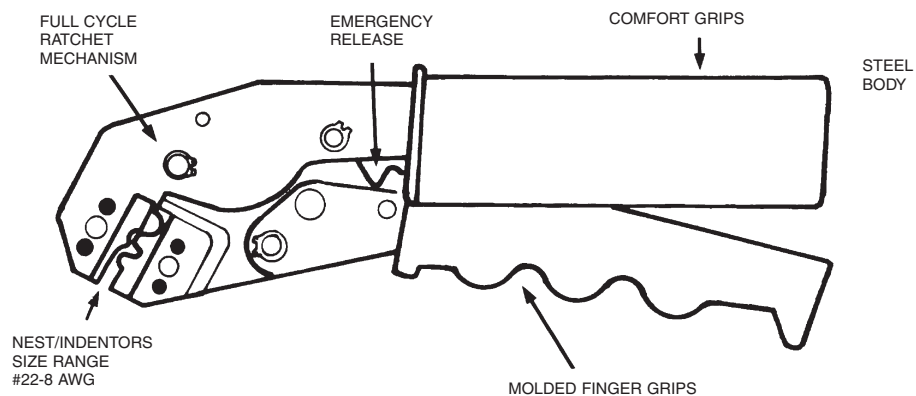

### TYPES MR8 AND MR10

#### HYTOOL™

#### FULL CYCLE RATCHET HAND TOOLS

The Types MR8- and MR10-series HYTOOLS™ incorporate a full cycle ratchet mechanism that provides a complete, positive crimp each time. Once started the ratchet mechanism does not allow the handles to be opened until after the full ratcheting cycle is completed. This provides for a completed crimp before a connector can be removed from the tool. The MR8- and MR10-series of tools are specifically designed with the ratchet mechanism completely inside the body of the tool without a path to reach and defeat the mechanism. This permits the tools to be used in the most critical applications including nuclear-class 1E terminations, heavy duty industrial, utility generation, OEM, aircraft, and other applications where a dependable electrical termination is needed. 5-year limited warranty.



#### BENEFITS

- Lightweight aluminum permits easier continuous usage.
- One tool to accommodate #22-10 AWG.
- Easy groove identification with color-coded dies.
- Long life expectancy with fully protected ratchet mechanism.
- Easy one-hand tool operation with long handle length for greater mechanical advantage.
- 5-year limited warranty.

#### SPECIFICATIONS

Length: 10-1/2"  
Weight: 1-1/2 lbs.

#### FOR USE ON

TOOL	AWG SIZE RANGE	CONNECTORS	
		BOX CAT. TYPES	BULK CAT. TYPES
MR8-1A	#10-22 AN Copper Cable	INSULUG™	YAE
MR8-9Q	#8-18 AN Copper Cable #10-22 AWG Sol. Cable #8-22 Str. AWG Cable	YAV BOX YSV BOX T T-F	YAV, YSV YAD, YAD-F
MR8-33S-1	#10-18 MIL-W-5086 Str.	YSE BOX YSE-H BOX	YSE YSE-H
MR8-83	#10-22	TN	YAES
MR8-85	#10-22	SN	YSE-HN
MR8-G96	#14-22	TP	BA
MR8-89-1	#10-22	TP, SP	BA, BS
MR8-91	#10-22	T	YAD
MR8-92	#14-22	PQ-R-D	PQ
MR8-G98	#10-22	YAV, T	YAV, YAV
<b>FINGRIP</b>			
MR10-D2	#10-12	PQ	PQ
<b>FORK-LOK</b>			
MR10-D3	#10-22	TP-LF	BA-EL
<b>FINGRIP</b>			
MR10-D4	#14-22	PQ	PQ
<b>NUCLEAR</b>			
MR10-G6	#10-22	YAES-K	

#### Features

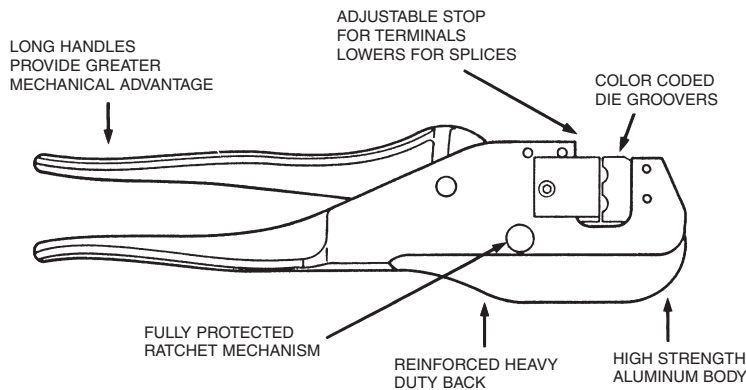

### TYPES MR15, MR18, MR20

#### HYTOOL™

#### FULL CYCLE RATCHET HAND TOOLS

The Types MR15, MR18 and MR20 series HYTOOL™ incorporate a full cycle ratchet mechanism that provides a complete, positive crimp each time. Once started the ratchet mechanism does not allow the handles to be opened until after the full ratcheting cycle is completed, unless the user actuates the emergency release lever. This provides for a completed crimp before a connector can be removed from the tool.

#### BENEFITS

- UL listed for use with BURNDY® connectors.
- Fully ratcheted tool to assure properly crimped connections.
- Easy groove identification with color coded dies.
- Maximum crimping comfort grips.
- Compact, narrow nose to work in confined areas.
- 5-year limited warranty.

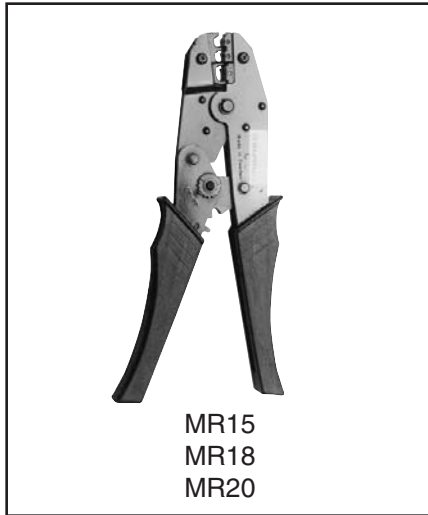

#### SPECIFICATIONS

Length: 8.86"  
Weight: 1.10 lbs.  
Open: 5.90"  
Closed: 2.50"  
Wire Range: #22-10 Awg.

#### FOR USE ON

##### MR15 Vinyl Insulated Terminals and Splices (Wire Range 22-10 AWG)

Vinyl Terminals		Vinyl Splices	
TP	BA	SP	BS
TP-F	BA-EF		
TP-Z	BA-EZ		
TP-LF	BA-EL		

##### MR18 Nylon Insulated Terminals and Splices

Nylon Terminals		Nylon Splices	
TN		SN	
TN-F		SNM	
YAES		YSE-HN	
YAES-F		YSES	

##### MR20 Uninsulated Terminals and Splices

Terminals		Splices	
T	YAD-F	YSV	
T-F	YAV-H*	YSV-H*	
YAV	YAV-H-F*		
YAD			
YAV-T-F			

\*Conductor crimps only.

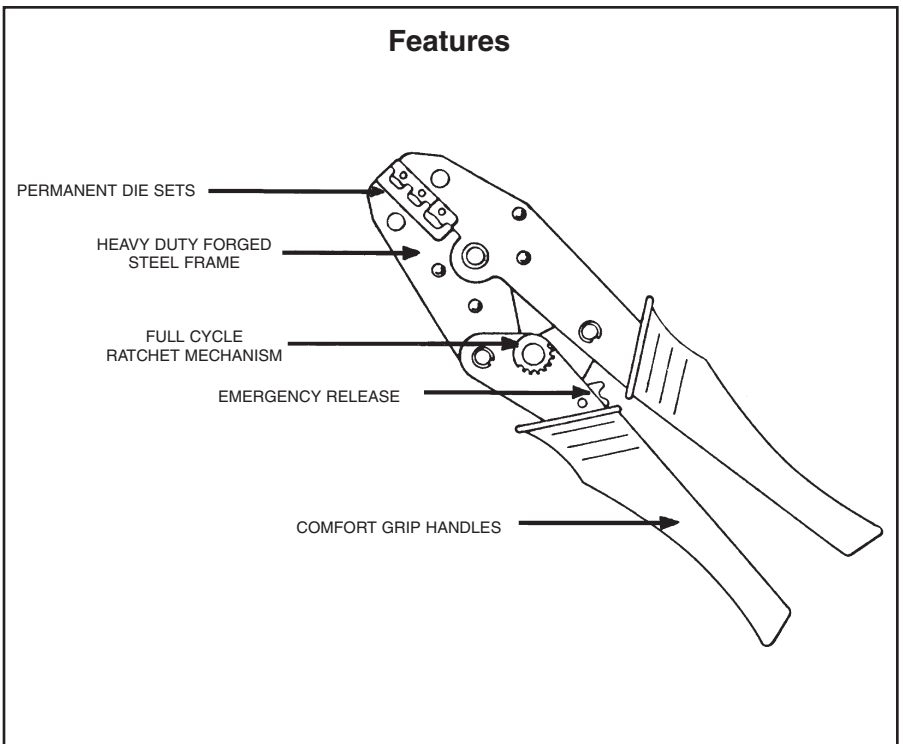



### TYPE MR4C

#### #9-4 AWG UNINSULATED TERMINALS AND SPLICES

Hand-held full cycle ratchet tool for #9-4 AWG uninsulated terminals and splices. Full cycle feature builds in reliability and removes the human factor from the completed installation. Long handles provide greater leverage. 5-year limited warranty.



#### SPECIFICATIONS

Length: 1-3/4"  
Weight: 2-1/4"

#### FOR USE ON

Terminals	YAV-L YA-L
Splices	YSV YSM YS-L

#### BENEFITS

- High strength aluminum body.
- Fully protected ratchet mechanism.
- Reinforced heavy duty back.
- Long handles provide greater mechanical advantages.
- Lightweight aluminum permits easier continuous usage.
- One tool to accommodate #9-4 AWG.
- Inspection (PG) gauges available to check each groove.

Groove		Gauge#
9-8	-	PG121-1
6	-	PG125-1
4	-	PG133-1

- Spring loaded indenter jaw holds connector in groove prior to crimping or ratchet engaging.
- 5-year limited warranty.

#### Features

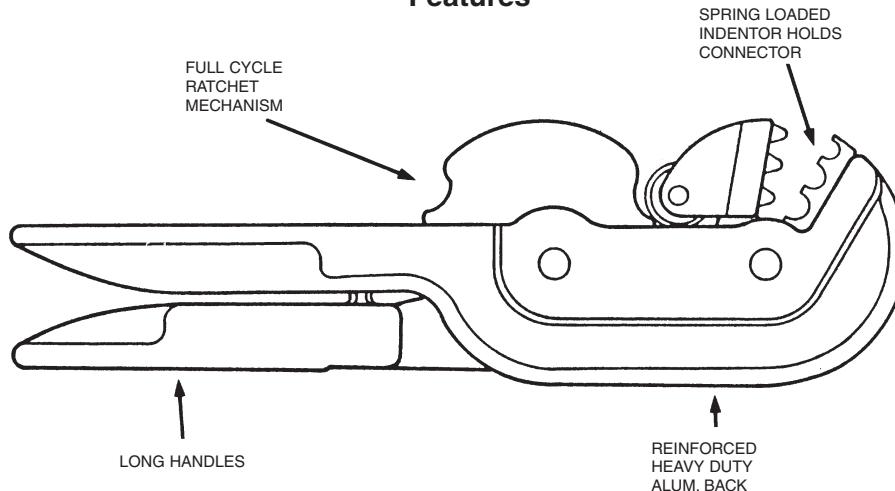



### TYPE Y1MRTC HYTOOL™

#8 – #1 COPPER HYDENT  
TERMINALS, SPLICES, AND  
#6–#6 THIN-WALL C-TAPS

Type Y1MRTC mechanical full cycle ratchet HYTOOL™ will accommodate copper compression HYDENT™ connectors for #8 through #1 code conductor, #8 through #2 Class I flexible strand copper conductor, and #2 solid. The color coded die wheel rotates to provide a proper match of the die and color coded connector. The die index is embossed on the crimped connector for permanent inspectability. A ratchet mechanism assures the tool must complete a full cycle before releasing.

#### SPECIFICATIONS

Length: 9.875"  
Height: 2.72" (closed)  
Width: .73"  
Weight: 1.7 lbs.  
Wire Range: #8-#1 code conductor,  
#8-#2 Class I Flex,  
#2 Solid  
Up to #6-#6 (Brown)  
type "YC-L CTAP"

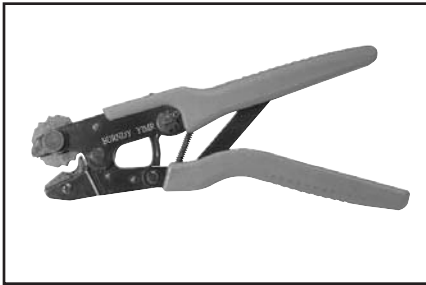

#### BENEFITS

- Rotating die is color coded to match color coded connectors
- Die index embossment allows permanent inspectability of installed connectors to insure consistently reliable and dependable connections.
- Molded comfort grips reduce fatigue during continuous use.
- Ratchet mechanism assures a complete crimp every time.
- Emergency release mechanism allows tool to be removed from connector in case of mistaken die choice or to reposition tool.
- 5-year limited warranty.

#### FOR USE ON

Cu Lug and Splice Connectors				
Copper Wire Size	Connector Catalog Types	Die Index # (Color)	# of Crimps Per Barrel Length	
			Std	Long
# 8 AWG Code & Flex	YA8C- YS8C- YAV8C- YSV8C-	49 (Red)	1	2
#6 AWG Code	YA6C- YS6C-	7 (Blue)	1	2
#6 AWG Code & Flex	YAV6C- YSV6C-			
#4 AWG Code	YA4C- YS4C-	8 (Grey)	2	4
#4 AWG Code & Flex	YAV4C- YSV4C-			
#3 AWG #2 Sol.	YA3C- YS3C-	9 (White)	2	4
#2 AWG Code	YA2C- YS2C-	10** (Brown)	2	4
#2 AWG Code & Flex	YAV2C- YSV2C-			
#1 AWG Code	YA1C- YS1C-	11** (Green)	2	4

\*\* Die Index 10 (Brown Die) and 11 (Green Die) use the same die wheel crimp groove.

Die Index Number Embossment on Connector after Crimp for inspection verification.

#### Y1MRTC

Wire Range: #8-#1 AWG Class B,  
#8-#2 Class I Flex.  
#2 Solid & #3 Stranded

#### Y1MRKIT

##### Kit Contains:

Y1MRTC Full-cycle Ratchet Tool  
Sturdy Metal Carrying Case

##### Terminals:

YA8CL, YA8CL1, YA6CL,  
YAV6CLTC14FX, YA4CL,  
YAV4CLTC14FX, YA2CL,  
YAV2CLTC516FX, YA1CL

##### Splices:

YS8CL, YS6CL, YS4CL,  
YS2CL, YS1CL

#### Y1MRTCKIT

##### Kit Contains:

Y1MRTC Full-cycle Ratchet Tool  
Sturdy Metal Carrying Case

##### Terminals:

YA8CL2TC14, YA8CL2TC38,  
YA6C2TC38, YA6CL2TC14,  
YA6CL2TC14E1, YA6CL2TC14E2,  
YA6CL2TC38, YAV6CL2TC14E2FX,  
YAV6CL2TC14FX, YA4CL2TC14,  
YA4CL2TC38, YA3C2TC38,  
YA2C2TC28, YA2CL2TC38

##### Thin-Wall C-Taps:

YC4L12

Cu C-Tap Connectors				
Catalog Number	Wire Size Cu Str. AWG		Die Index # (Color)	# of Crimps
	Run	Tap		
YC10L12	14	16-14	49 (Red)	1
	12	16-14		
	10	16		
YC8L12	10	10	7 (Blue)	1
	8	12		
YC6L12	8	10-8	8 (Grey)	1
	6	12-10		
YC4L12	6	8-6	10 (Brown)	2
	5,4	12-8		

### TYPE M8ND

#### #26-8 AWG TERMINALS AND SPLICES

Hand-held full cycle ratchet tool for #8-26 AWG terminals and splices. Full cycle feature builds in reliability and removes the human element from the completed installation. Long handles provide greater leverage. 5-year limited warranty.



#### SPECIFICATIONS

Length: 10-3/4"  
Width: 1-3/4"

#### FOR USE ON

##### Terminals

YAD	BA-E
YAD-F	BA-EF
YAE	BA-ES
YAE-F	BA-EZ
YAE-Z	BA-EL
YAES	
YAEV-H	
YAEV-L	
YAV	
YAV-F	
YAV-H	
YAV-H-F	

##### Splices

YSV	YSM
YSV-H	YRV-L

#### BENEFITS

- Fully protected ratchet mechanism.
- Reinforced heavy duty back.
- Long handles provide greater mechanical advantages.
- Easy groove identification with color-coded dies.
- 5-year limited warranty.

#### Features

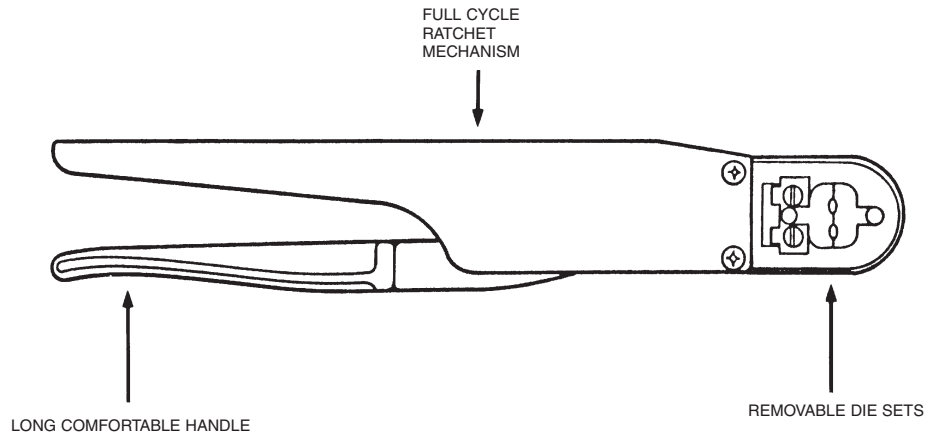

### TYPE MRC840

#### HYTOOL™

#### #8-4/0 AWG NON-INSULATED COPPER CONNECTORS

The MRC840 Mechanical Rotating Crimp Tool will accommodate copper compression BURNDY® HYDENT™ connectors from # 8 AWG str. - 4/0 AWG str. copper conductor. Butting steel jaw and over center cam action assure full crimp force.

Rotatable die wheel is color-coded and stamped with the conductor size to provide an easy match of the die and color-coded BURNDY® HYDENT™ connector. BURNDY® YA and YS series connectors are U.L. listed when installed with this tool. 5-year limited warranty.



### SPECIFICATIONS

Length: 26"  
Height: 8"  
Weight: 8-1/4 lbs.

### Features and Benefits

- Comfort grip handles.
  - ◇ Aids in prevention of hand slippage.
  - Reduces fatigue during continuous use.
- Heat treated steel jaws
  - ◇ Reduces jaw buckling and misalignment under heavy loading.
- Approximately 9000 crimp cycle life.
  - ◇ Lasts longer than imitations and will still be working when others have worn out.
- Multiple grip selections on rotatable die wheels.
  - ◇ No lost dies, 9 position color-coded rotatable die wheels.
- High strength fasteners.
  - ◇ Increase tool life by reducing tool wear.
- Plated jaws.
  - ◇ Provide enhanced corrosion protection.
- Engraved crimp groove (Die index number).
  - ◇ Die index embossment allows permanent inspectability of installed connectors to ensure consistently reliable and dependable connections.

### Features

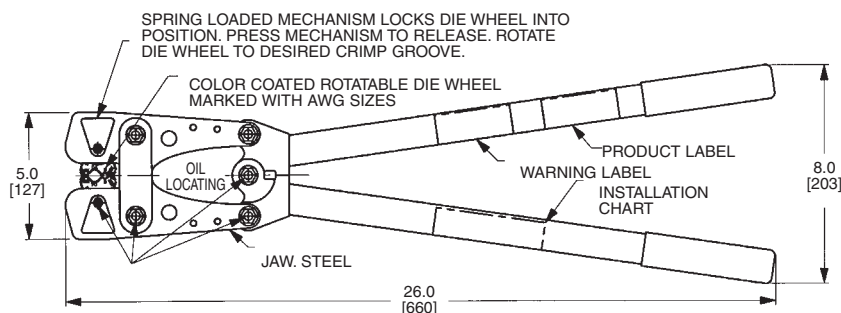

### TYPE MY

#### DIELESS HYTOOL™

#8 STR. THROUGH 250 KCMIL  
COPPER- #8 STR. THROUGH  
4/0 STR. ALUMINUM  
CONDUCTORS

#### BENEFITS

- Save on capital investment with the type MY HYTOOL™ that accommodates a wide range of connector/conductor combinations from #8 str.-250 kcmil.
- Save time, money, and lower installed cost with the original dieless MY tool design. No separate dies required to purchase or to lose.
- Fast and easy tool setting for the connector/conductor combination simply by aligning the white scribe on the nest die with the wire size on the gauge for proper crimping results.
- Easy to adjust nest die with knurled steel knob and machine threads.
- Quality tool with precision machines indenter, component parts and tool body.
- Fast, medium and high volume crimping is easily accomplished by bench mounting the type MY tool in the BMY-BCH-MT bench mount adapter. A single bolt holds the MY HYTOOL™ securely using the .31 dia. mounting hole in the bench mount adapter.



#### BENEFITS (CONTINUED)

- High quality rugged tool design manufactured from heavy duty forged steel with strong reinforced back and handles.
- Covered handles available on the MY29-3C, MY29-11C and MY29-3CF HYTOOL™.
- Comfort grip handles for long periods of usage.
- Compression terminals and splices are UL listed and CSA certified when installed with type MY HYTOOL™.
- 5-year limited warranty.

#### SPECIFICATIONS

Length: 22.65"  
Width: 8 lbs. approx.  
Depth: 4.86"  
Width: 1.12"

Bench Mount Adapter  
Cat. No. BMY-BCH-MT

#### FOR USE ON

TOOL	CONNECTORS
<b>MY29-3</b>	
<b>MY29-3C</b>	Copper-YA, YA-L, YS-L
<b>MY29-3CF</b>	Aluminum-YA-A, YS-A
<b>MY29-11</b>	Copper-YA, YA-L, YS
<b>MY29-11C</b>	YAV-FX YS-L, YAV-L, YSV-L
<b>MY28</b>	YAV-L, YSV-L
<b>MY28-4</b>	YAV-A-L, YSV-A-L, YAV-A-R
<b>MY28-6</b>	YAE-L, YAEV-RS, YAEV-H, YAEV-RH

#### ACCESSORIES

##### BMY-BCH-MT BENCH MOUNT ADAPTER

##### MY29 UNIVERSAL KIT CONTENTS:

1 EA	MY29-11
50 EA	YA8CLBOX
50 EA	YAV6CLTC14FX
50 EA	YAV4CLTC516FX
50 EA	YAV2CLTC516FX
50 EA	YAV1CLTC38FX
10 EA	YAV25LTC38FX
10 EA	YAV26LTC516FX
10 EA	YAV27LTC12FX
10 EA	YAV28LTC12FX
10 EA	YA29LBOX
1 EA	CASE

<b>MY29-3</b>	#8 str.-250 kcmil Copper commercial (code) cable
<b>MY29-3C (covered handles)</b>	30 Navy-250 Navy Copper Navy Cable
<b>MY29-3CF (fully covered)</b>	#8 str.-4/0 str. Aluminum commercial (code) cable
<b>MY29 UNIVERSAL KIT</b>	#8 str.-250 kcmil Copper commercial (code) cable
<b>MY29-11</b>	30 Navy-250 Navy Copper Navy cable
<b>MY29-11C (covered handles)</b>	#8 str.-4/0 str. Flexible copper mine machine cable
<b>MY28</b>	#8 str.-4/0 str. Copper aircraft cable
<b>MY28-4</b>	#8 str.-4/0 str. Aluminum aircraft cable
<b>MY28-6 (nylon covered connector)</b>	#8 str.-2/0 str. Copper aircraft cable (flexible)

#### Features

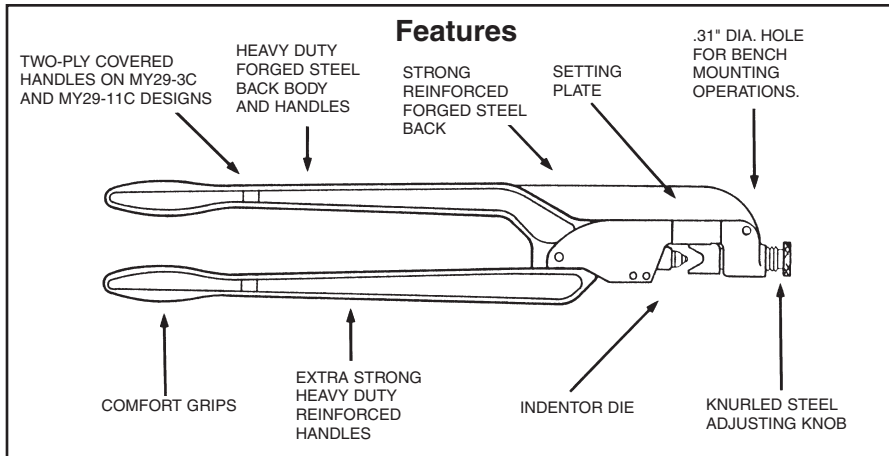

### TYPE OH25

#### HYTOOL™

#### ONE-HAND OPERATION, DIELESS, FULL CYCLE RATCHET TOOL

Installs service entrance splice connectors.  
Conductor range: #10 through 1/0.

The OH25 incorporates a full cycle ratchet and cam mechanism allowing an easy, one-hand crimping operation. The ratchet mechanism provides for properly completed crimps every time before the tool can be removed from the connection. The OH25 is designed to install 5/8" INSULINK™ and LINKIT™ service entrance connectors with only (1) crimp per connector end, speeding installation time. The single crimp covers the complete contact area, eliminating possible overlapping or failure to make the proper number of crimps. 5-year limited warranty.



#### BENEFITS

- One crimp speeds installation.
- No dies to lose.
- Long dependable life with forged steel jaws and stainless steel indenter.
- Convenient hole to hang tool.
- Protection of internal parts provides long life.
- Ratchet mechanism provides proper crimp and uniform quality installations.
- Easy one-hand tool operation with spring loaded comfort grip handles.
- Proven reliable with years of dependable service.
- 5-year limited warranty.

#### SPECIFICATIONS

Handle force: 50 lbs. max.  
Max force developed: 6,000 lbs.  
Weight: 2 lbs. 11 oz.  
Length: 12-1/4"

#### ACCESSORIES

##### Leather Holster

Cat. #PT4583

##### No-Go Gauge

Cat. #PT8504

The PT8504 NO-GO Gauge is used to check the OH25 HYTOOL™ crimp dimensions.

#### FOR USE ON

- 5/8" Service entrance sleeves
- INSULINK™ Type ES (insulated) #10 through 1/0 str.
- LINKIT™ type YSU (bare) #8 through 1/0 str.
- 5/8" neutral tension sleeves HYSPLICE™ types YS-S YCS-R YDS-AT #4 through 1/0.
- AYP HYPLUG™ #6-1/0 str.

#### Features

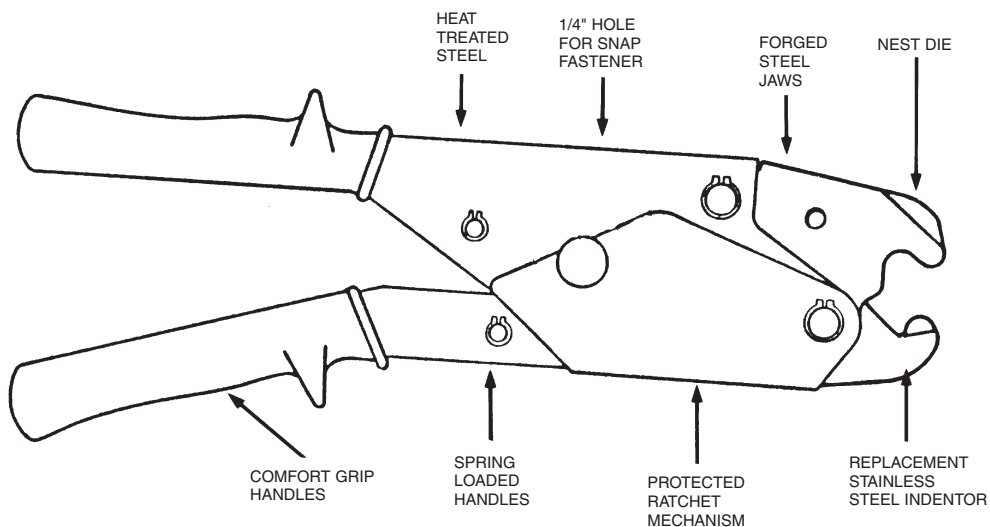

### TYPE OUR840

#### 840 POPPER HYTOOL™

ONE-HANDED OPERATION, OVERHEAD/UNDERGROUND, FULL CYCLE RATCHET TOOL INSTALLS A RANGE OF CONNECTORS (TAPS, SPLICES, TERMINALS)

The OUR840 incorporates a full cycle ratchet and cam mechanism allowing an easy, one hand crimping action. Designed for low maintenance operation. The OUR840 has a five (5) year warranty. The ratchet mechanism provides for properly completed crimps every time before the tool can be removed from the connection. With nest and indenter dies, it will install 5/8" INSULINK™ and LINKIT™ service entrance connectors with only one (1) crimp per end. With the use of reduced handle force "X" dies, additional splices, taps, and terminals can be properly installed. The die inserts snap into the permanent groove easily with one hand and lock securely in the tool with the spring loaded positive lock die retainer buttons. Tool operation is simple:

- Slip the tool over the connector.
- The first few strokes grip the connector.
- Stroke until automatic tool release signifies a completed compression.

#### INSTALLATION TOOLING

CONDUCTOR (COPPER)	CONNECTOR (COPPER)			DIE	OUR-840		
	HYLUG™ TERM	HYLINK™ SPLICE	COLOR CODE		DIE INDEX	(# CRIMPS) STD.	LONG
#8 AWG STR.	YA8C-	YS8C-	RED	X8CRT	49	1	2
#6 AWG STR.	YA6C-	YS6C-	BLUE	X6CRT	7	1	2
#5 AWG STR.	YA5C-	YS5C-	BLUE	X5CRT	7	1	2
#4 AWG STR.	YA4C-	YS4C-	GRAY	X4CRT	8	1	2
#2 AWG STR.	YA2C-	YS2C-	BROWN	X2CRT	10	1	2
#1 AWG STR.	YA1C-	YS1C-	GREEN	X1CRT	11	1	2
1/0 AWG STR.	YA25-	YS25-	PINK	X25RT	12	2	4
2/0 AWG STR.	YA26-	YS26-	BLACK	X26RT	13	2	4
3/0 AWG STR.	YA27-	YS27-	ORANGE	X27RT	14	3	6
4/0 AWG STR.	YA28-	YS28-	PURPLE	X28RT	15	3	6
250 Kcmil	YA29-	YS29-	YELLOW	X29RT	16	4	8

WVT DIES MAY BE SUBSTITUED

CONDUCTOR (ALUMINUM)	CONNECTOR (ALUMINUM)			DIE	OUR-840	
	HYLUG™ TERM	HYLINK™ SPLICE	COLOR CODE		DIE INDEX	NO OF CRIMPS
#8 AWG STR.	YA8CA-	YS8CA-	BLUE	X8CART	374	2
#6 AWG STR.	YA6CA-	YS6CA-	GRAY	X6CART	346	2
#4 AWG STR.	YA4CA-	YS4CA-	GREEN	X4CART	375	3
#2 AWG STR.	YA2CA-	YS2CA-	PINK	X2CART	348	4
#1 AWG STR.	YA1CA	YS1CA	GOLD	X1CART	471	3
1/0 AWG STR.	YA25A-	YS25A-	TAN	X25ART	296	4
2/0 AWG STR.	YA26A-	YS26A-	OLIVE	X26ART	297	4
3/0 AWG STR.	YA27A-	YS27A	RUBY	X27ART	467	4
4/0 AWG STR.	YA28A-	YS28A-	WHITE	X28ART	298	6



#### BENEFITS

- Allows proper crimping of sleeves and terminations in crimping underground applications.
- Proper crimps are assured with butting surface inspection and full cycle ratchet mechanism.
- Uses reduced handles force "X" dies.
- One tool for most service applications.
- Improved service through redesign and improvement of many internal parts.
- Easy visual field check for proper tool adjustment with butting surfaces.
- Easier tool operation is provided with mini strokes and anti-slip grips.
- Nest and indenter dies available.
- W-28K cutter die permits use of OUR840 tool as a cable cutter. Conductor range: #4-4/0 ACSR. Aluminum and Copper.
- UL Listed connections when color coded "X" dies are used on BURNDY® connectors.
- 5-year limited warranty.

#### SPECIFICATIONS

Max. crimp force: 8,000 lbs.  
 Max Handle Force: 8 lbs. approx.  
 Weight: 2 lbs. 14 oz.  
 Length: 13"

#### FOR USE ON

##### SELECTED APPLICATIONS

Aluminum connectors from #8 AWG to 250 kcmil.

#### ACCESSORIES

Cat. No. **OUR840-WH** Leather Holder

- Top grain cowhide saddle leather.
- Large grommet. (Order Separately)

**OUR840-WC** Metal carrying case with die tray.

- Holds one (1) OUR840 and up to eleven (11) "X" dies. Dies not included. (Order Separately) OUR840 DIES

X-DIES CAT. NO.	DIE INDEX	RECOMMENDED "W" DIE CRIMP RATIO
<b>XN8G</b>	BG	2*
<b>XBG</b>	BG	2
<b>X161</b>	161	3*
<b>X241</b>	241	2
<b>X245</b>	245	2
<b>X247</b>	247	2
<b>X249</b>	249	2
<b>X660</b>	660	2
<b>X840</b>	840	1
<b>XOH25</b>	-	OH 25 EQUIV.

\* Overlap crimps

\* "W" Dies with a die index listed above are not recommended for the OUR840. Since the standard "W" Dies are wider than the "X" Dies, additional crimps are required depending on the connector and the die index.

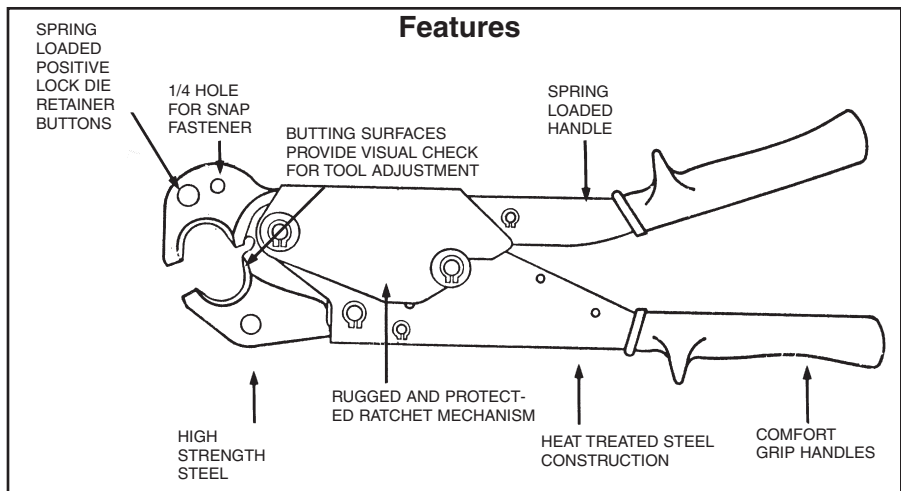



### TYPE MD6-8

#### HYTOOL™

#### HAND-OPERATED TOOL

Installs full range of connectors (taps, splices, terminals): #14 through 4/0. Applications: Full Tension and Non-Tension.

The MD6-8 has a five (5) year warranty and is designed to provide over 90,000 reliable crimps installing full-tension and non-tension connectors.

The MD6-8 installs almost all of the line, pole and house connections in the Burndy Compression Connector Program with only one (1) extra die set (W-BG). The tool has two (2) permanent die grooves, "O" and "D<sub>3</sub>" for distribution tap connectors. The "D<sub>3</sub>" groove also serves as a seat for die inserts to install additional splices, taps and terminal connectors. The die inserts snap into the D<sub>3</sub> groove easily with one hand and lock securely in the tool with the spring loaded positive lock die retainer buttons.

#### BENEFITS

- Proper crimps are assured with butting steel jaws.
- No additional dies required for "O" and "D<sub>3</sub>" size tap connectors.
- Increased strength and greater bearing area is provided with larger steel bolts.
- Fast, easy, one-hand die insertion.
- No lost dies with spring loaded positive lock die retainer buttons.
- Easy visual field check for proper tool adjustment with orange alignment guide lines.
- Over 90,000 crimps provided with Teflon impregnated steel backed bronze bushings.
- Full crimp force assured with over center cam action.
- Easy tool adjustment with allen wrench.
- Operator protection provided with butt stops and heat shrink tubing.
- Long life expectancy provided with select clear hickory handles and lightweight high strength aluminum alloy castings.
- Easier tool operation is provided with bent handles and anti-slip grips.
- The "D<sub>3</sub>" groove accommodates the complete line of type "W-" die inserts.
- 5-year limited warranty.



#### MD6 Tool Variations

- MD6** Standard MD6 with permanent "BG" (5/8") and "D<sub>3</sub>" grooves. Installs CABLELOK CRIMPIT and HYCRIMP™ Tap Connectors with one additional die insert (W-O). All other tool features and connector ranges are the same as the MD6-8 described above.
- MD6-4** Standard MD6 with permanent "BG" (5/8") and "D<sub>3</sub>" grooves and straight fiberglass handles 24" long. Fiberglass rated at 100KV per foot for 5 minutes.
- MD6-14** Standard MD6 with permanent "BG" (5/8") and "D<sub>3</sub>" grooves and straight fiberglass handles 19" long including bent aluminum grips. Fiberglass rated at 100KV per foot for 5 minutes.
- MD6-12** Standard MD6-8 jaws with permanent "O" and "D<sub>3</sub>" grooves and straight fiberglass handles 24" long. Fiberglass rated at 100KV per foot for 5 minutes.
- MD6-6** "Snub-Nose" variation of MD6 has a permanent "D<sub>3</sub>" groove in jaw. Recommended for use where space for tool jaw is limited.
- MD6-37** Permanent 161, 162, 163, 171 dies in the jaw. (J, M&P, T & X)
- MD6-38** Permanent K, BG, C, dies in the jaw.

#### SPECIFICATIONS

Crimp force: 9000 lbs.  
Length: 25-3/8"  
Weight: 6 lbs.

#### Quality Unsurpassed!

Life cycle tested under full operating forces for over 90,000 cycles successfully without adjustment or any parts replacement.

#### FOR USE ON

- Copper, Aluminum, ACSR, Copperweld, Alumoweld, Steel, 6201, 5005, Compressed and compact conductors.
- Copper Taps: #10 sol.-2/0 str.
- Aluminum, ACSR Taps: #14 sol.-4/0 ACSR
- Stirrups: #6 ACSR-4/0 ACSR
- Overhead Full Tension Deadend, Full Tension Splices, Non Tension Splices, and Terminals Conductor Range: #10 str.-4/0 ACSR.
- Code conductor connectors: #6-4/0 str. Copper and Aluminum

#### To Check Tool Adjustment

Simply close the tool handles until the jaws initially butt. When the orange alignment grooves are in line, the tool is in correct adjustment.

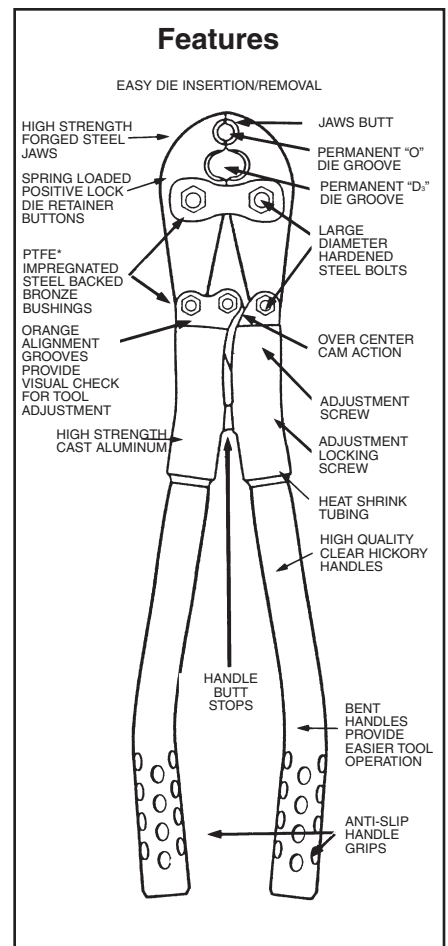



### TYPE MD7 POSI-PRESS HYTOOL™

#### HAND-OPERATED TOOL

The MD7 POSI-PRESS HYTOOL™ is a composite polymer handle installation tool that requires no adjustment for the life of the tool. This assures users of the MD7 tool, that all connections installed with the MD7 POSI-PRESS HYTOOL™ are consistent and reliable over the life of the tool. This new technology tool provides a visual wear indicator that makes verification of the tool's condition easy to determine. Once the tool has worn beyond its useful life, it can be returned to BURNDY's Tool Repair Center for re-fitting at a fraction of the price of a new tool.

Installs full range of connectors, (taps, splices, terminals): #14 Awg through 4/0 Awg.

Applications: Full-Tension and Non-Tension.

The MD7 series of tooling has a five (5) year warranty and is designed to provide over 99,000 reliable crimps installing both full-tension and non-tension connectors.

The MD7-8 POSI-PRESS HYTOOL™ installs almost all of the line, pole, and house connections in the Burndy Compression Connector Program with only one (1) extra die set (W-BG). The MD7-8 tool has two (2) permanent die grooves, "O" and D<sub>3</sub>" for distribution tap connectors. For other tool versions, see the MD7 Tool Variations sections below. The "D<sub>3</sub>" groove also serves as a seat for die inserts to install splices, taps, and terminal connectors. The die inserts snap into the "D<sub>3</sub>" groove easily with only one hand, and lock securely in the tool with the spring loaded, positive lock, die retainer buttons. Handles have been tested at 100 Kv per foot for five (5) minutes.



#### FEATURES

- Ergonomically designed, one-piece, composite polymer handles.
- Comfort grip handles.
- Time-proven steel jaw designs.
- No tool adjustment required.
- 99,000 crimp/cycle life.
- Positive lock, spring loaded die retainer buttons.
- Permanent "D<sub>3</sub>" die groove.
- PTFE impregnated steel/bronze bushings and stainless steel pins.
- Electroless nickel plated jaws and jaw links.

#### BENEFITS

- Easier tool operation due to unique handle design, and anti-slip grips.
- Improves operation by preventing slipping.
- Proper crimps are assured with butting jaws.
- Provides reliable and consistent crimps every time.
- Lasts up to 6 times longer than cheap imitations, and will still be working when others have long since worn out.
- No lost dies and one-hand die insertion.
- Allows use of the complete line of Burndy "W" and "X" die inserts.
- Increases life of tool by reducing tool wear.
- 5-year limited warranty

#### SPECIFICATIONS

- Crimp force: 9,000 lbs.
- 60 lbs. Handle Force
- Length: 25"
- Width: 8" (at handle end)
- 4-1/2" (at jaw end)
- Width: 7 lbs.

#### Unsurpassed Quality that no one else can match!

Life cycle tested under the full range of operating forces for over 99,000 cycles successfully without failure or any parts replacement.

#### FOR USE ON

- Copper, Aluminum, ACSR, Copperweld, Alumoweld, Steel, 6201 5005.
- Compressed and compact conductors
- Copper Taps: #10 sol. - 2/0 str.
- Aluminum, ACSR Taps: #14 sol. - 4/0 ACSR
- Stirrups: #6 ACSR - 4/0 ACSR
- Overhead Full Tension Deadend, Full Tension Splices, Non Tension Splices, and Terminals Conductor Range: #10 str. - 4/0 ACSR
- Code conductor connectors: #6 - 4/0 str. Copper and Aluminum

#### MD7 Tool Variations

**MD7-8** MD7 with permanent "O" and "D<sub>3</sub>" grooves. Installs almost all of the line, pole, and house connections in the Burndy Compression Connector Program with only one (1) extra die set (W-BG).

**MD7-6** "Snub-Nose" variation of MD7 has a permanent "D<sub>3</sub>" groove jaw. Accepts the full-line of BURNDY® "W" and "X" die inserts. Recommended for use where space for tool jaw is limited.

**MD7** Standard MD7 with permanent "BG" (5/8") and "D<sub>3</sub>" grooves. Installs Cablelok Crimpit and HYCRIMP™ Tap connectors with one (1) additional die insert (W-O). All other tool features and connector ranges are the same as the MD7-8.

N-16

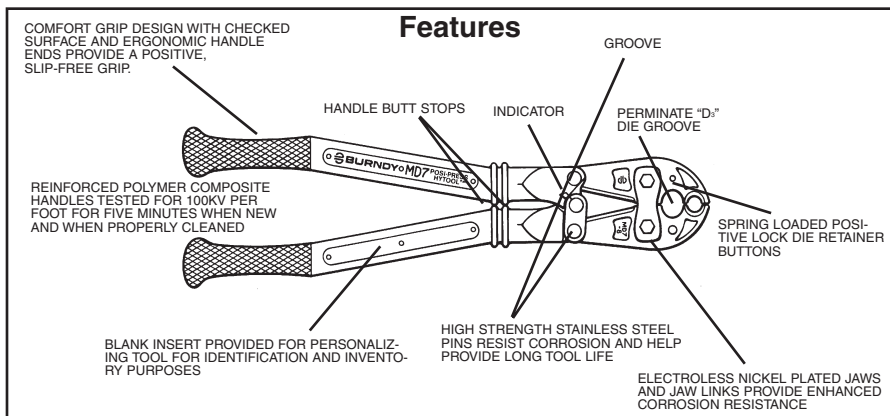

### TYPE MD7-34R POSI-PRESS HYTOOL™

#### HAND-OPERATED FULL CYCLE RATCHET TOOL

The MD7-34R POSI-PRESS HYTOOL™ has a full stroke ratchet that assures the user has cycled the tool completely for a consistent crimp every time. The tool handles are manufactured from a new reinforced composite polymer that requires no adjustment for the life of the tool. This new tool design assures users that all connections installed with the MD7-34R are consistent and reliable over the life of the tool. A visual wear indicator provides easy verification of the tool's condition. An emergency ratchet release allows tool removal in case of mistaken die choice or to reposition tool. The MD7-34R crimps color coded lugs and splices for #8-500 kcmil class B code conductor and #8-350 kcmil Cu Flex conductor. It will also crimp thin wall C-Taps from #12 - 3/0 AWG class B code conductor. The color coded W-VT dies snap into the jaw grooves easily with only one hand and lock securely into the tool with the spring loaded, positive lock, die retainer buttons. The die index number is engraved in the crimping groove to emboss the finished connection. This makes inspection and verification of proper installation an easy process. Due to the one piece handle design, if the tool ever wears beyond it's useful life, it can be returned to BURNDY's Tool Repair Center for refitting at a fraction of the price of a new tool. A rubber covered version, the MD7-34R-C, is available.



#### FEATURES

- Full Stroke Ratchet Mechanism.
- Ergonomically designed, one piece, composite polymer handles.
- Comfort grip handles.
- Time-proven forged steel jaw designs.
- No tool adjustment required.
- Positive lock, spring loaded die retainer buttons.
- PTFE impregnated steel/bronze bushings and stainless steel pins.
- Color Coded Dies.
- DIE index embossed on finished connection.

#### SPECIFICATIONS

- Crimp force: 9,000 lbs.
- Length: 26"
- Width: 8" at handles 4-1/2" at jaws
- Jaw Covering: EPDM Rubber (MD7-34RC).
- Handle Material : Reinforced composite polymer
- Warranty: 5 years

#### MD7-34 Tool Variations

- **MD7-34R** - #8-500 Cu HYDENT™, Full Stroke Ratchet
- **MD7-34R-KIT 1** - MD7-34R, metal carrying case and all dies for #8-500 kcmil Cu HYDENT™ and C-Taps
- **MD7-34** - Supplied without the ratchet mechanism
- **MD7-34-KIT1** - MD7-34, metal carrying case, and all dies for #8-500 kcmil Cu HYDENT™ and C-Taps for #12 - 3/0 AWG.

#### FOR USE ON

- Copper Lugs and Splices #8-500 kcmil. Types YA, YA-L, YA-L-TC, YA-L-NT, YS-L, YS, YST, YA-TC
- Copper Lugs and Splices #8-350 kcmil Flex. Types YAV-L-TC-FX, YA-LB, YA-TC-FXB, YSV-L, YAV-L-NT-FX, YAV-L-FX, YAV-FXB
- Copper Battery Lugs #8-350 kcmil Flex. Types YAG-TC-LD
- Thin wall C-taps #12 - 3/0 AWG. Types YC-L

#### BENEFITS

- Easier tool operation due to unique handle design, and anti-slip grips.
- Grips and handle knobs improve operation by preventing slipping.
- Butting jaws assure proper crimps.
- Wear indicator allows instant inspection of calibration.
- Full cycle ratchet assures complete consistent crimp.
- High grade hardware increases tool life and durability.
- Allows use of complete line of BURNDY® W-VT, W-RT and X-RT series dies.
- Color Coded dies simplify selection of correct connector and die combinations.
- Die index embossment on crimp provides easy inspection and quality assurance.
- 99,000 crimps without needing adjustment.
- 5-year limited warranty.

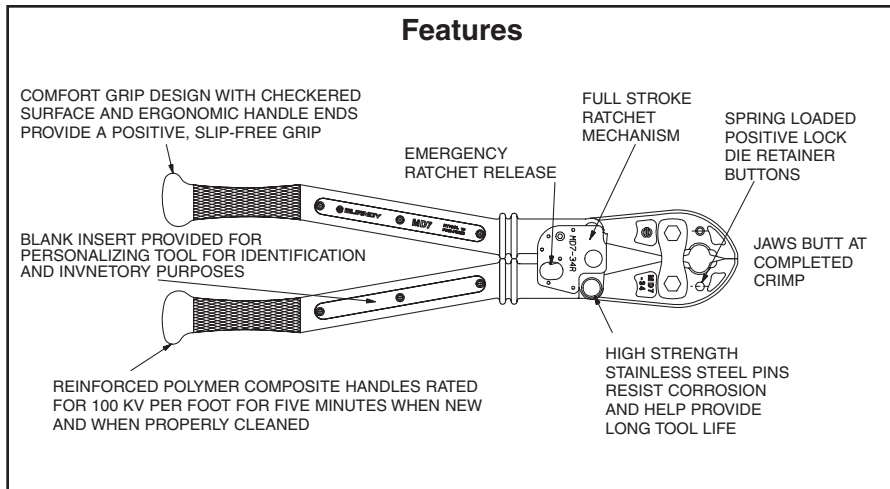

### TYPE MD6/MD7

#### TOOLING ACCESSORIES

##### Dies for Special Applications

(See present installation tool index in reference section for complete W-Die listing.)

##### W-BG

The W-BG die is a double groove die set requiring only one (1) crimp per end on service entrance sleeves and only 1/2 the number of crimps on other 5/8" sleeves.

##### W-28K

The W-28K cutter die permits use of MD6/MD7 type tools as a cable cutter. Conductor range: 4-4/0 ACSR, Aluminum or Copper.

##### Protective Jaw Covers



##### Cat. No. MD6-CP1

The laminated vinyl covers, a non-conductive material, are provided for the MD6/MD7 HYTOOL™ to avoid damage. Compact in size, the covers snap easily into place over the jaw edges without obstructing vision.

The MD6-CP1 fits all MD6/MD7 tool variations except the Snub-Nose MD6-6/MD7-6 type design. Supplied as a set.

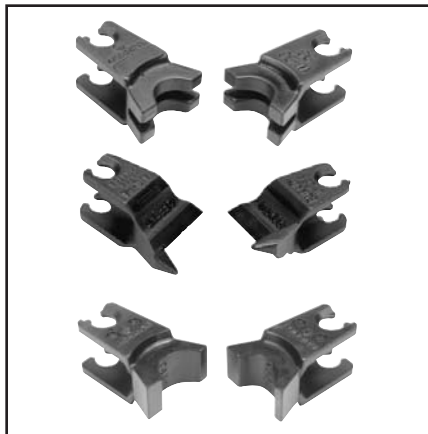

##### Non-Bowing Dies

##### Cat. Nos. W-687 and W-702

The Non-Bowing die sets install one-piece, full-tension UNISPLICE™ sleeves on ACSR conductors without bowing.

##### UNISPLICE™ ONE-PIECE SLEEVES:

**W-687** Installs: #4 ACSR 6/1, 7/1-YDS4RL and YDS4RLY  
#2 ACSR 6/1-YDS2RL and YDS2RLY

**W-702** Installs: #2 ACSR 7/1-YDSO21RL and YDSO21RLY  
1/0 ACSR-YDS25RL and YDS25RLY



##### Cat. No. PT4946

##### Compact Steel Die Case

Compact die case for (12) "W" or "X" die sets. Dies purchased separately.

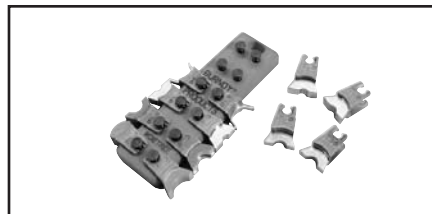

##### Cat. No. WDIETREE

##### W Die Holder

This innovative W-Die Holder replaces the standard metal carrying case designed for BURNDY® W-Dies. Its straight forward design allows for easy insertion of the W-Dies onto the holder, providing greater flexibility and secure storage.



##### Cat. No. PT4952-1

##### Steel Carrying Case

The PT4952-1 steel carrying case provides storage and protection for the MD6 tools with or without rubber covers plus up to (18) die sets. Tool and die sets not included. Fits MD6, MD6-6, MD6-8, MD6-14, MD6-37, MD6-38, MD7 and MD7-6.



##### PT4931-1

##### Die Button Repair Kit



##### Cat. No. PT4925

##### Canvas Bag

The PT4925 is a sturdy canvas bag for protecting the MD6/MD7 tools with or without rubber covers plus up to (9) die sets. Dies purchased separately.



##### Cat. No. PT6733

##### Hot-Line Tool Carrying Bag

The PT6733 is a heavy-duty, adjustable canvas bag for the storage and protection of Hot-Line Tools. The bag accommodates 48", 60" and 72" variations of the MD6 and Y35 Hot-Line Tools.



##### Cat. No. PT6744

The semi-rigid Neoprene cover, a non-conductive material, is provided for the MD6-6 "Snub-Nose" HYTOOL™ to avoid damage. Fits all MD6-6 Snub-Nose variations.

## TYPE MD6R

### HYTOOL™

#### FULL-CYCLE RATCHET TOOL

Installs full range of connectors (Taps, Splices, Terminals): #6 through 4/0 AWG.

Applications: Overhead and underground — full-tension and non-tension. Use MD6-6R2 for code cable terminals and splices through 500 kcmil copper.

The MD6R full-cycle ratchet tool installs all the same connectors using the same “W”-type dies that the MD6 tool installs plus the addition of code cable connectors through 500 kcmil copper.

A maximum handle force of 40 lbs. plus short handle opening and angled head combine to provide an ideal tool for difficult overhead and tight underground applications. Five-year limited warranty.



#### BENEFITS

- Precise crimping everytime is provided with the ratchet mechanism and automatic release only after five (5) handle strokes.
- Easy tool operation is provided with 40 lbs. maximum handle force reducing possible back strain.
- Convenient operator usage for difficult to reach overhead and tight underground trench applications is provided with the angled head, short handle stroke and minimal handle force requirements.
- Easy handling and insertion is provided with spring loaded handles.
- The D<sub>3</sub> groove accommodates the complete line of “W” die inserts.
- 5-year limited warranty

#### MD6R Variations:

Cat. No.	Permanent Die Grooves
<b>MD6R</b>	BG (5/8”) and D <sub>3</sub>
<b>MD6-6R</b>	D <sub>3</sub> Snub-Nose
<b>MD6-6R-2</b>	D <sub>3</sub> Modified for copper color coded dies #8 through 500 kcmil.
<b>MD6-8R</b>	O and D <sub>3</sub>

#### Accessories:

Cat. No. **PT4925**

The PT4925 is a heavy-duty canvas carrying bag for the storage and protection of the MD6...R tools. Pockets for dies are included.

Cat. No. **PT17188**

#### ABS Cover Kit

The PT17188 is the heavy-duty ABS plastic cover kit including (3) piece ABS cover, label and hardware.

#### SPECIFICATIONS

Output force:	12,000 lbs.
Handle input force:	40 lbs.
Number of strokes:	5
Weight:	10 lbs.
Length :	24”

#### FOR USE ON

- Copper, Aluminum, ACSR, Copperweld, Alumoweld, Steel, 6201, 5005, Compressed and compact conductors.
- Copper Taps: #10 sol.- 2/0 str.
- Aluminum, ACSR Taps: #14 sol.- 4/0 ACSR.
- Stirrups: #6 ACSR- 4/0 ACSR.
- Overhead Full Tension Deadends, Full Tension Splices, Non Tension Splices, and Terminals Conductor Range: #10 str.-4/0 ACSR.
- Code conductor connectors: #6-500kcmil. Copper.

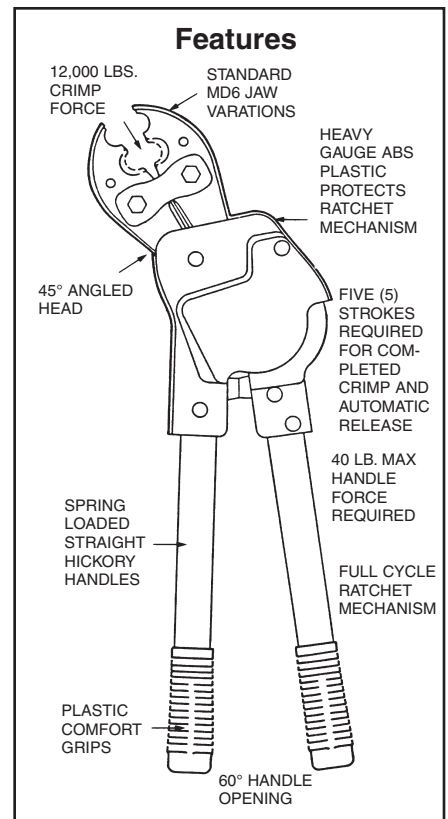

### MD6 HOTSTICK TOOLS

The MD6 Type Hotstick tools incorporate either a pantograph toggle action handle or straight handles. They use standard MD6 Type jaws so that they will do everything the standard MD6 will do only they can be used for energized installations. The fiberglass handles are rated at 100 kv/ft for 5 minutes. 5-year limited warranty.



### SPECIFICATIONS

Cat. No.	Handle Length	Weight/Lbs.
<b>MD6HS60</b>	60"	15.5
<b>MD6HS72</b>	72"	16.5
<b>MD6-6HS60</b>	60"	15.5
<b>MD6-6HS72</b>	72"	16.5
<b>MD6-8HS60</b>	60"	15.5
<b>MD6-8HS72</b>	72"	16.5
<b>MD6-AH48</b>	48"	13.75
<b>MD6-6AH48</b>	48"	13.75
<b>MD6-8AH48</b>	48"	13.75

### FOR USE ON

- Copper, Aluminum, ACSR, Copperweld, Alumoweld, Steel, 6201, 5005.
- Compressed and compact conductors.
- Copper Taps: #10 sol.-2/0 str.
- Aluminum, ACSR Taps: #14 sol.-4/0 ACSR.
- Stirrups: #6 ACSR-4/0 ACSR.
- Overhead Full Tension Deadends, Full Tension Splices, Non Tension Splices, and Terminals Conductor Range: #10 str.- 4/0 ACSR.
- Code conductor connectors: #6 - 4/0 str. Copper and Aluminum.

### BENEFITS

- The MD6-HS type Hot-Line Tool incorporates a pantograph, toggle-action design to install connectors with the same handle force as the standard MD6-type tooling.
- All fiberglass handles rated at 100KV per foot for five minutes.
- Angled head and lightweight makes connector installation easier.
- Supplied with MD6, MD6-6, and MD6-8 jaw variations.
- The MD6-AH type Hot-Line Tool incorporates an angled head to make hard to reach hot-line connections easier.
- Straight 48" fiberglass handles rated at 100 KV per foot for five minutes.
- Supplied in MD6, MD6-6 and MD6-8 jaw variations.
- 5-year limited warranty.

### Features

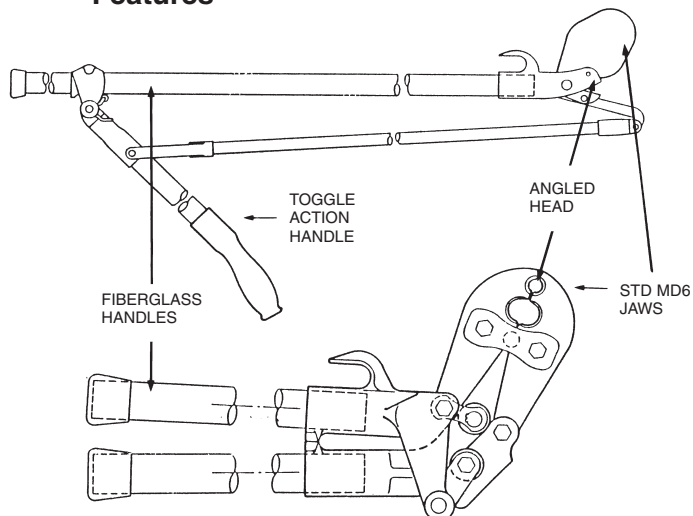



### TYPE Y500CT-HS

#### L'IL CRIMP™

#### 6 TON - HYDRAULIC CRIMP TOOL

The BURNDY® Y500CT-HS HYPRESS™ connector installation tool provides 6 U.S. Short tons of force in a compact and easy to use, hand-held hydraulic tool. The Y500CT-HS incorporates a specialized latch style head with a generous working stroke for a wide variety of crimping applications. The specialized head allows interference-free closures on tap connectors up to the BURNDY® YHD-400 size. The head is fitted onto a light-weight tool body with handles that are ergonomically designed to provide slip-free grip and easier crimping. The tool features a patented high speed ram advance mechanism that minimizes crimp cycle time along with an ergonomic trigger drain mechanism that allows the ram to return to the preset position. The tool accommodates all BURNDY® "X", "W", and "W-VT" style dies that seat in the permanent "D<sub>3</sub>" crimping groove. Installation applications include #6 AWG to 600 kcmil copper lugs and splices, #6 AWG to 350 AWG aluminum lugs and splices, and up to 4/0 aluminum tap connections. The permanent "D<sub>3</sub>" groove and 180 degree rotatable head are standard on the Y500CT-HS.

Each Y500CT-HS HYPRESS™ tool uses BURNDY® dies and off-the-shelf connectors that are available worldwide. Your Y500CT-HS HYPRESS™ comes equipped with a durable metal carry case to hold the tool and a multitude of die sets.



#### Features and Benefits

- Light weight latch head design.
  - ◇ Provides enhanced clearance for tap connectors.
- 180° head rotation.
  - ◇ Versatile tool head allowing user crimp access into tight spaces.
- Ergonomic handle design.
  - ◇ Easier operation, helping reduce fatigue.
- Audible pressure "pop-off" valve.
  - ◇ Indicates properly completed crimp.
- Permanent "D<sub>3</sub>" crimp groove accepts all BURNDY® "W" and "X" dies.
  - ◇ Standard die design with proven performance.
- Durable metal carrying case.
  - ◇ Provides superior protection and stores all accessories.
- High speed ram advance.
  - ◇ Provides faster crimps.
- Handle trigger drain.
  - ◇ Convenient ram retraction.
- 5-year limited warranty.
  - ◇ Customer satisfaction and technical support.

#### SPECIFICATIONS

Output Force: 6 tons (5.4 metric tons)  
 Tool Weight: 7.8 lbs. (3.5 kg)  
 Total Strokes: 7 (w/o connector)  
 Height: 6.0" (152 mm)  
 Length: 17.6" (447 mm)

#### FOR USE ON

- Copper, Aluminum, ASCR, Steel, Copperweld, Alumoweld, 6201, 5005, Compressed, Compact, Stranded & Solid conductors
- Installs splices, taps, or terminations:
  - #8 - 600 kcmil Copper Str
  - #8 - 350 kcmil Flex
  - #8 - 350 AWG Aluminum



#### RANGE TAKING DIES

- WDC4500:** #4-500 Cu STR.  
 #2-4/0 Cu FLEX  
 UL and CSA for use on YA and YS series.  
 Also for use on YAV and YSV series.
- WDA8300:** #8-300 Al  
 #6-400 Cu STR.  
 #2-4/0 Cu FLEX  
 UL and CSA for use on YA, YS, YA-A, and YS-A series. Also for use on YAV and YSV series.

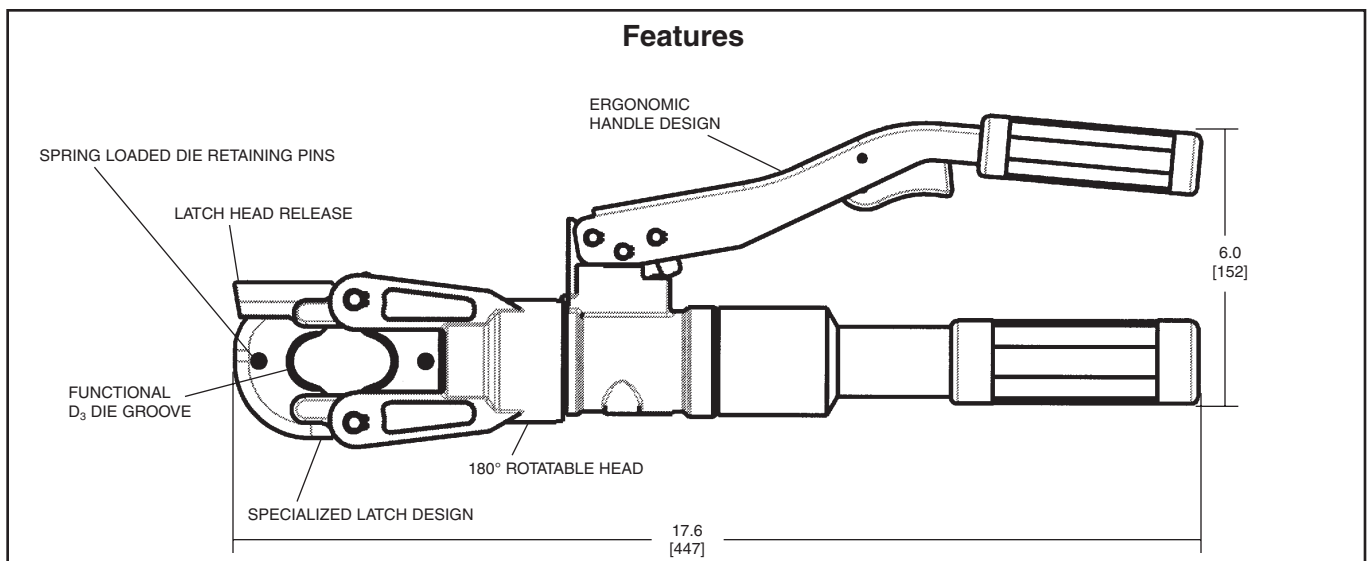

### TYPE Y35 AND Y35-2 HYPRESS™

#### HAND-OPERATED - HYDRAULIC TOOL

The Y35 HYPRESS™ Tool incorporates a C-shaped, rotatable head for overhead line work and compression grounding applications. The hook style head with extensive ram travel provides for easy tapping and splicing of overhead lines as well as HYGROUND™ compression grounding systems.

The Y35-2 HYPRESS™ head, body and handles are covered with 3/16" rubber for tool impact protection.

Order the hot-line handle assembly, "U" dies and accessories separately. 5-year limited warranty.



#### SPECIFICATIONS

	Y35	Y35-2
Force developed:	12 tons	12 tons
Operating pressure:	10,000 psi	10,000 psi
Weight (less case):	13 lbs.	13-1/2 lbs.
Overall length:	23-1/4"	24"
Head width:	4-3/4"	6"
Molded Covering:	Body & Handles	Head, Body and Handles

#### FOR USE ON

Copper #8 str.-500 kcmil Code Cables	Terminals-grounding YGH, YGHA, YGF Splices-grounding YGS, YGHS
Copper #8 str.-kcmil and up to 3/4" ground rod	Taps-grounding YGHC-C, YGHP-C YGHR-C
Copper #8 str.-750 kcmil Code Cables N30-N500 Navy Cables Flexible and Extra Flex	Terminals Uninsulated YA, YA-2N, YA-L, YA-LB YA-2LN Terminals Insulated YAEV-L Box, YAEV-L YAEV-H, YAEV-RS, YAEV-RH Splices To Size 400 kcmil YS, YS-T, YS-L YS-LB, YSV-L Box YSV-L, YSM
Aluminum #8 str.-750 kcmil Code Cables	Terminals YA-A AYP, AYPO Splices To Size 350 kcmil YSA, YRB, YS-AT
ACSR	See Burndy Overhead Transmission and Distribution Catalog Module

#### BENEFITS

- Compact "C" shaped head allows easy placement and removal from continuous conductor lengths.
- Easy to position tool for work with 180° head rotation.
- Versatile and economical-tool works with all commonly used copper, aluminum and ACSR conductors from #6 str. to #556.5 26/7 stranding.
- Body and handles covered with 3/16" molded rubber for tool impact protection.
- Easy die change accomplished with push button die locks.
- Quality assurance is provided with automatic 10,000 PSI blow-off pressure release valve for positive crimping.

#### BENEFITS (CONTINUED)

- Rapid ram advance reduces installation time by eliminating need to pump handles to advance ram to connector.
- Saves installation time with trigger controlled return release which returns ram to its preset starting point.
- Long continuous usage is aided with comfort grip handles.
- Compression terminal and splice connectors are UL listed and CSA certified when installed with recommended die set.
- 5-year limited warranty.

#### Features

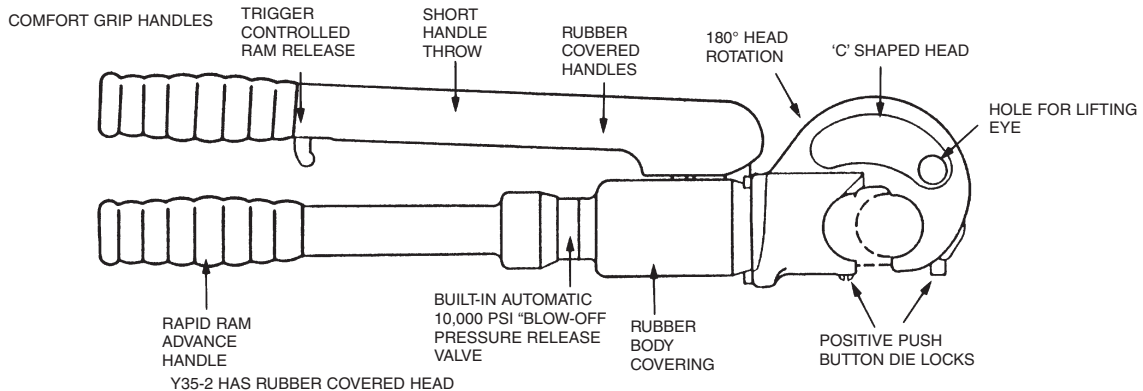



### Y35 SERIES ACCESSORIES



#### PT 29279-2 Force Test Gauge

The PT 29279-2 Force Test Gauge is designed to provide an accurate visual reading of the output force produced by the hand-hydraulic Y35, Y35-2, Y39 and Y750 HYPRESS™ tools. It is not recommended for any remote powered HYPRESS™ heads such as the Y35BH. The PT 29279-2 Force Test Gauge is factory calibrated and inspected to very stringent tolerances providing the customer accuracy and an excellent means for quality assurance control. Supplied with padded storage case.

#### BENEFITS

- Easy to read
- Provides means for quality assurance control.
- Blank (test) "U" dies are provided for testing procedure.
- Tool output force is applied to load cell for visual read out of the resulting force on the dial.
- The blank (test) "U" set is included with the Force Test Gauge.
- An easy to read operating and maintenance manual is included.

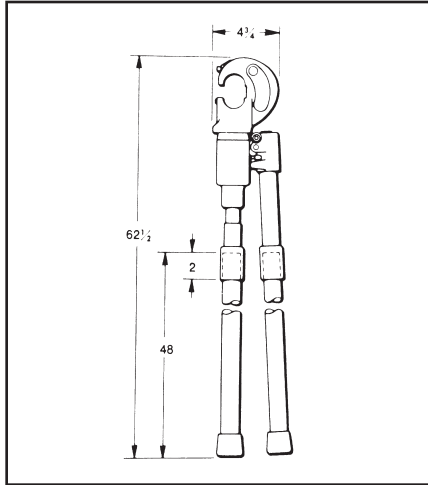

#### Cat. No. HH5-RL48 Hot-Line Handle Assembly

The HH5-RL48 is a 48" long fiberglass handle assembly that easily attaches to a standard Y35 HYPRESS™ tool. Rotation of the handles controls the rapid ram advance and release mechanisms. The handles are rated at 100KV per foot for five minutes. The Catalog Number does not include the Y35.

For factory assembled unit order Catalog Number **Y35-16**.



#### Cat. No. PT6733 Hot-Line Tool (Heavy-Duty) Carrying Bag

The PT6733 is a heavy-duty, adjustable canvas bag for the storage and protection of hot-line tools. The bag accommodates 48" through 72" variations of the Y35 and MD6 hot-line tools.



#### Cat. No. PT29291 Die Case

Steel case designed for storage and protection of "U" dies used with the Y35 and other BURNDY® tools. Holds 15 die sets. Length 9 1/2", width 6", height 1-1/2". Dies sold separately.

#### Y34A INDENTOR ADAPTOR:

To use Y34A indentors in a Y35, Y39, or Y750 tool.

Cat. No. **Y35P3**

#### SEAL REPAIR KIT:

Cat. No. **Y35/Y39 REP KIT A**

#### Steel Carrying Case

Cat. No. **PT2972** for Y35

Cat. No. **PT29360** for Y35-2

### TYPE Y39 HYPRESS™

#### HYDRAULIC TOOL - HAND-OPERATED

The versatile, lightweight Y39 weighs 13 lbs., and its small 3-1/8" wide head rotates 180° for convenience and flexibility. The tool provides 12 tons of crimping power, while its built-in overload valve automatically releases pressure when the crimp is completed.

The Y39 is designed for easy die insertion and removal without ball checks or set screws. Its rapid ram advance and trigger-controlled release eliminate unnecessary pumping after every crimp. 5-year limited warranty.



#### BENEFITS

- Easy to work in small tight spaces with only a 3-1/8" wide compression head and short handle throw.
- Easy to position tool for work with 180° head rotation.
- Versatile and economical-tool works on all commonly used copper and aluminum conductors from #6 str. to 750 kcmil.
- Body and handles covered with 3/16" rubber.
- Easy to locate and hold dies in position with the positive push button die locks plus die changing is accomplished easily without ball checks or set screws.
- Easy to remove or lock into position die holder with recessed spring latch plus leather strap to prevent loss.

#### BENEFITS (CONTINUED)

- Quality assurance is provided with automatic 10,000 psi "blow off" pressure release valve for positive crimping.
- Rapid ram advance eliminates requirement for pumping handles to advance ram to connector.
- Trigger release allows ram to return to preset position.
- Long continuous usage is aided with comfort grip handles.
- Compression terminal, tap and splice connectors are UL listed and CSA certified when installed with the Y39 tool and recommended die set.
- 5-year limited warranty.

#### SPECIFICATIONS

Force developed: 12 tons  
 Operating force: 10,000 PSI  
 Weight - less case: 12 lbs.  
 Overall length: 23"  
 Max. head width: 3-1/8"  
 Die accommodation: U-dies

#### FOR USE ON

##### COPPER

#6 AWG -750 Kcmil str.  
 Code Cable  
 N30 - N650 Navy Cable  
 Flexible and Extra Flexible  
 Terminals -Uninsulated  
 YA, YA-L, YA-LB, YGH, YGHA  
 Splices & Tees - Uninsulated  
 YS, YS-L, YS-LB, YS-T, YSP-T, YST

##### COPPER- AN or AIR

#6 AWG-#4/0 str. Code Cable  
 AN6-AN #4/0 Aircraft Cable  
 Flexible and Extra Flexible  
 Terminals - Uninsulated  
 YAV-L Box, YAV-L, YAV-Rs Box, YAV-RS  
 Splices - Uninsulated  
 YSV-L Box, YSV-L

##### COPPER-INSULATED TERMINALS

#8 AWG - #2/0 str. Code Cable  
 AN8 - AN #2/0 Aircraft Cable  
 Flexible and Extra Flexible  
 Terminals-Insulated  
 YAEV- L Box, YAEV- L, YAEV- RS Box,  
 YAEV- RS, YAEV-RH

##### COPPER-TAPS

#12 AWG Solid-250 kcmil  
 Taps -YC-C, YGHC -C, YGHP -C, YGHR -C,  
 YH, YCHC -TC

##### ALUMINUM

#8 AWG-750 kcmil str.  
 Code Cable  
 Terminals-YA-A  
 Splices-YS-A, YS-AT, YRB

##### ALUMINUM

#6 str.-500 kcmil  
 Taps -YFD, YFN, YFO

#### Features

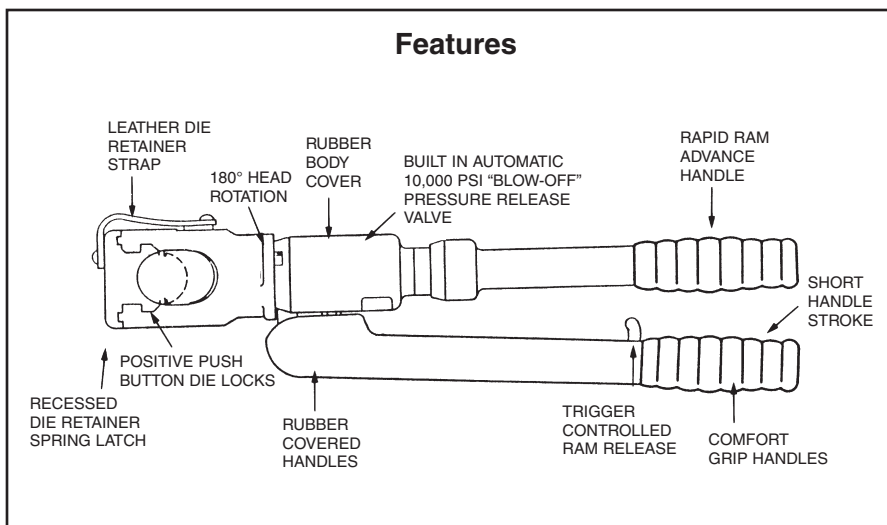

## TYPES Y750HS AND Y750-2HS RUBBER COVERED HEAD

### 750 REVOLVER HYPRESS™

HYDRAULIC HAND OPERATED TOOL — 12 TON CRIMP FORCE

CONDUCTOR RANGE:  
#12-750 KCMIL CU/AL  
AND #4-556.5 KCMIL ACSR

The BURNDY® Y750HS Series HYPRESS™ is a wide mouth (1.65") hand operated hydraulic 12 ton crimping tool for use on virtually all compression applications. The C-shaped head rotates 355° relative to the handle and is mated to a patented rapid advance pump. The Y750HS provides easy tapping, splicing, and terminating of overhead lines, the full line of HYGROUNDTM compression grounding connectors, NEC cable connections, and N30-N650 Navy cable connections.

The Y750HS accepts all BURNDY® "U" dies for use on conductor ranges of #12-750 kcmil AL/CU and #4-556.5 kcmil ACSR conductors.

The Y750-2HS HYPRESS™ has a rubber-covered head and handles for tool impact protection.



### BENEFITS

- Covers a wide range of applications with a lightweight, self-contained system and provides easy tool removal from continuous conductors with its C-shaped head.
- Easy tool positioning with its 355° head rotation.
- Patented rapid advance pump for faster crimps.
- Exposed positive die lock buttons for easy die change out and die retention.
- Handle trigger drain for convenient ram retraction.
- Quality assurance is provided with an audible "Pop-Off" pressure relief valve.
- Comfort grip handles help ease operator fatigue with continuous use.

### SPECIFICATIONS

Force developed:	12 tons
Weight:	14.5 lbs. (5.4 kg)
Length:	23.5" (7162 mm)
Height:	2.75" (838 mm)
Width:	8.0" (2438 mm)
Jaw opening:	1.65" (42 mm)

### FOR USE ON

- Tension Sleeves
 

Copper	#8 sol.-500 kcmil
Aluminum	#8 sol.-587-2 kcmil
ACSR	#4-556.5 kcmil
- Taps
 

Copper	#14 sol.-500 kcmil
Aluminum	#8-500 kcmil
- Aerial Cable
 

Copper	#6-500 kcmil
--------	--------------
- Terminals & Splices
 

Aluminum	#8-750 kcmil
Copper	#8-750 kcmil
ACSR	#4-556 kcmil
- HYGROUNDTM (Compression Ground)
 

Copper	#8-500 kcmil (cable/ground rod)
Ground Rods	1/2" - 1" Diameter

### ACCESSORIES:

Cat. No.	Description
<b>Y750HSCASE</b>	Plastic Carrying Case for Y750HS and Y750-2HS

### Features

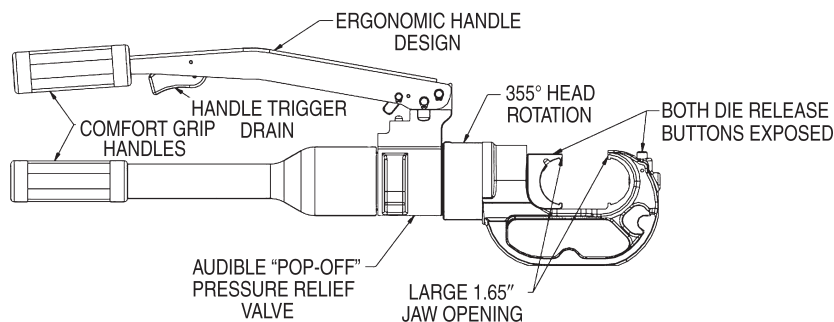

### BENEFITS (Continued)

- Long life expectancy from the company that provided the industry with the first self-contained hydraulic tool in 1934.
- Rubber covered head and handles on Y750-2HS for tool impact protection.
- Supplied with high impact plastic carrying case.
- 5-year limited warranty.

### TYPE Y644HS DIELESS HYPRESS™

#### THE “1” CRIMP RANGE TAKING TOOL

HYDRAULIC HAND OPERATED  
TOOL — 11 TON CRIMP FORCE

#6 - 1000 KCMIL COPPER  
HYLUG™ TERMINALS AND  
HYLINK™ SPLICES

#6 - 750 KCMIL ALUMINUM  
HYLUG™ TERMINALS AND  
HYLINK™ SPLICES

The Y644HS dieless HYPRESS™ is a hand operated 11 ton hydraulic crimping tool. Only 1 crimp is required for each wire termination for both long and standard length barrels on HYLUG™ terminals and HYLINK™ splices.

The Y644HS has a latch style head which provides easy tool removal from continuous conductor runs. The head rotates 355° relative to the handles and is mated to a patented rapid advance pump. The Y644HS weighs only 15 pounds and delivers 11 tons of crimping force. The result is easy terminating and splicing using BURNDY® HYLUG™ and HYLINK™ terminals and splices.

**Y644HS Dieless HYPRESS™ Range Taking Capabilities.** The following size HYDENT™ lugs and two way splices, when crimped with the Y644HS Dieless HYPRESS™ Tool, produce the following UL listed range taking capabilities.

ALUMINUM CONNECTORS		COPPER CONNECTORS	
Standard Wire Size	Expanded Wire Range	Standard Wire Size	Expanded Wire Range
#6 AWG	#6 AWG	#6 AWG	#6 AWG
#5 AWG	#5-#6 AWG	#5 AWG	#5-#6 AWG
#4 AWG	#4-#6 AWG	#4 AWG	#4-#6 AWG
#3 AWG	#3-#6 AWG	#3 AWG	#3-#6 AWG
#2 AWG	#2-#6 AWG	#2 AWG	#2-#6 AWG
#1 AWG	#1-#2 AWG	#1 AWG	#1-#6 AWG
1/0 AWG	1/0-#1 AWG	1/0 AWG	1/0-#6 AWG
2/0 AWG	2/0-#1 AWG	2/0 AWG	2/0-#4 AWG
3/0 AWG	3/0-#1 AWG	3.0 AWG	3/0-#2 AWG
4/0 AWG	4/0-#1 AWG	4/0 AWG	4/0-#1 AWG
250 kcmil	250-1/0 AWG	250 kcmil	250-1/0
300 kcmil	300-2/0 AWG	300 kcmil	300-2/0
350 kcmil	350-3/0 AWG	350 kcmil	350-3/0
400 kcmil	400-4/0 AWG	400 kcmil	400-4/0
500 kcmil	500-4/0 AWG	500 kcmil	500-4/0
600 kcmil	600-250 kcmil	600 kcmil	600-250
750 kcmil	750-500 kcmil	750 kcmil	750-500
		800 kcmil	800-500
		1000 kcmil	1000-750



#### SPECIFICATIONS

Output Force: 11 tons (22,000 lbs.)  
Weight: 15 lbs. (5.6 kg)  
Length: 22.5" (572.5 mm)  
Height: 2.75" (70 mm)  
Width: 8.0" (207 mm)

#### FOR USE ON

AWG/KCMIL SIZE RANGE	COPPER	CONNECTOR TYPE
#6-1000 kcmil		Terminals YA-L, YA-2LN, YA, YA-FXB YA-2N, YA-L-2TC, YA-L-FX YAB-4N, YA-L-TC, YA-2L, YA-4N, YEV-P-FX, YE-P, 4E-P-FX Splices YS-L, YS, YS-T
#6-750 kcmil	Aluminum	Terminals YA-A, YA-A-TN Splices YS-A
#6-750 kcmil	Aluminum	HYPLUG™ AYP, AYPO

#### BENEFITS

- Dieless system, eliminates the need to purchase and maintain dies.
- Patented rapid advance pump for faster crimps.
- Pressure relief “Pop-Off” valve provides audible indication that crimp is complete.
- Handle trigger drain for convenient ram retraction.
- 355° head rotation for versatile tool head positioning in tight areas.
- Easy inspection and positive identification is provided with the BURNDY “⊕”.
- Comfort grip handles help ease fatigue with continuous use.
- Supplied with high impact plastic carrying case.
- 5-year limited warranty.

#### ACCESSORIES

- Cat. No.  
**Y644HSCASE**  
• Plastic Carrying Case

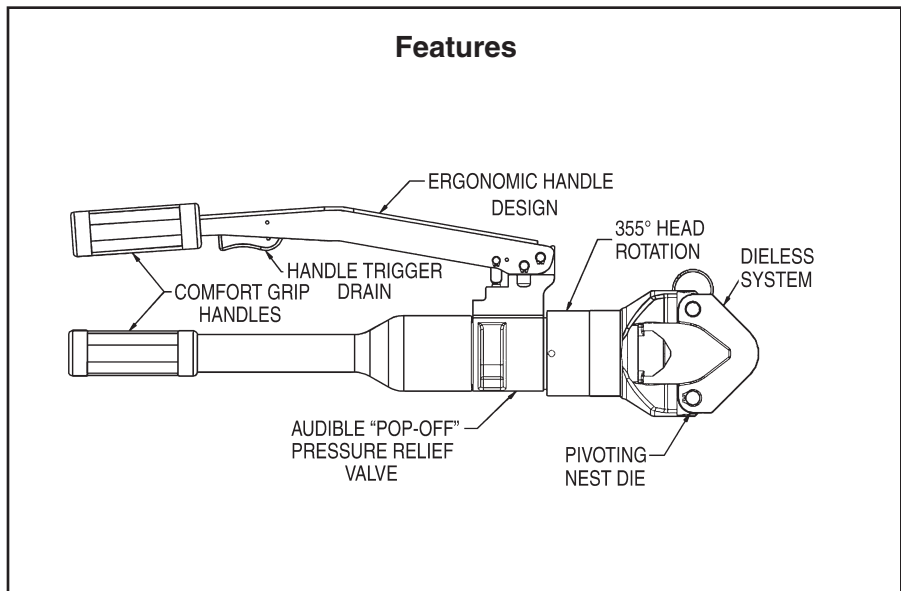

### TYPE 4-POINT™ Y81KFT

#### DIELESS HYPRESS™

#### HYDRAULIC HAND OPERATED CRIMPING TOOL

#8 – 1000 KCMIL COPPER HYLUG™  
TERMINALS and HYLINK™ SPLICES

#8 – 750 KCMIL ALUMINUM HYLUG™  
TERMINALS and HYLINK™ SPLICES

The Y81KFT 4-POINT™ dieless HYPRESS™ is a hand operated 6 ton hydraulic crimping tool for use on a wide variety of terminal and splice compression applications. The Y81KFT incorporates a dieless latch style head that provides easy tool removal from continuous conductor runs and eliminates the need to purchase and maintain dies. The head rotates 360° relative to the handles and is mated to a patented rapid advance pump. The Y81KFT weighs only 12 pounds and delivers 6 tons of crimping force. The result is easy termination and splicing using BURNDY® HYLUG™ and HYLINK™ terminals and splices.

The Y81KFT is supplied with a molded high impact plastic case and comes complete with a 5-year limited warranty.

**Y81KFT dieless HYPRESS™ Range Taking Capabilities:** The Y81KFT provides range taking capabilities that is UL and CSA listed for Copper (Code, Compact and Flex) and Aluminum (Code and Compact) conductors when used in conjunction with BURNDY® HYLUG™ terminals and HYLINK™ splices. *See chart for connector, conductor and range taking combinations.*



#### Features and Benefits

- Dieless installation system.
  - ◇ Eliminates the need to purchase and maintain dies.
- UL Listed and CSA Certified with Range Taking Capabilities
  - ◇ Provides the installer with a UL Listed and CSA Certified crimps with Range Taking Capabilities when used in conjunction with BURNDY® HYLUG™ Terminals and HYLINK™ Splices
- Flip top head design.
  - ◇ For easy loading and removal of installed terminals and splices, saving time.

#### SPECIFICATIONS

**Output Force:** 6 tons (12,000lbs)  
(5450 kg)  
**Weight:** 12 lbs (5.45 kg)  
**Length:** 25.6 in (650 mm)  
**Height:** 7.7in (196 mm)  
**Width:** 2.5in (64 mm)

#### FOR USE ON

- Copper, Aluminum, Compressed, Compact, Stranded, Solid and Flex Conductors.
- Installs Splices, Taps and Terminations:
  - #8 - 1000 kcmil Copper (YA, YA-L, YS, YS-L, YS-T, Y-R )
  - #8 - 777.7 (750 Nominal Flex Wire Size) kcmil Flex (YA-FX, YAV, YA-L-FX, YS, YSV-FXB)
  - #8 - 750 kcmil Aluminum (YA-A, YS-A)
  - #8 - 750 kcmil Aluminium Pin Adapters (AYP, AYPO)

- Audible pressure "pop-off" valve and die embossment providing 360° inspectability.
  - ◇ Assures proper crimps with both audible and visual indicators for the installer.
- Handle Trigger release.
  - ◇ Convenient ram release located in the handle.
- Advanced high speed pump design.
  - ◇ Provides fast crimps, longer life, efficiency, and reliability.
- 360 Degree head rotation.
  - ◇ Versatile tool head positioning lets the user get into tight areas easier.
- Durable high impact formed carrying case.
  - ◇ Provides tool protection and stores all accessories.
- 5-year limited warranty.
  - ◇ Customer satisfaction and support.

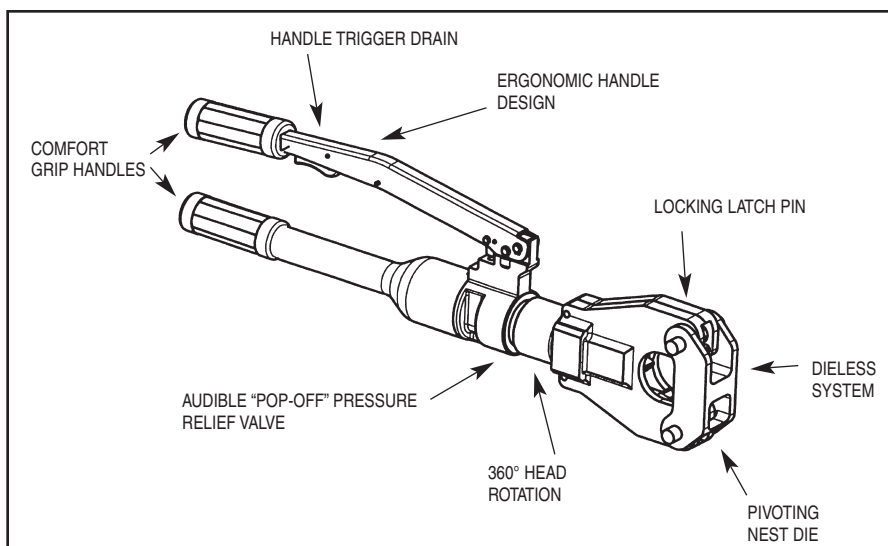

### YCUT129ACSR

#### Hydraulic Hand Operated Cutter

The BURNDY® YCUT129ACSR incorporates a specialized latch style cutting head that allows interference-free closure for mid-span cuts. The cutter head rotates 180 degrees to allow users to get into tight areas easier. The YCUT129ACSR weighs only 11.4 pounds, yet delivers 7 tons of cutting force. The YCUT129ACSR with its hardened steel blades is capable of cutting up to 1.29" diameter bare or insulated copper and aluminum cable, 1113 ACSR, 5/8" ground rod, 1/2" rebar and 5/8" diameter soft steel bolts 1/2" standard guy strand and up to 3/8" EHS guy strand.

The YCUT129ACSR comes equipped with a high impact formed carrying case to hold the tool and accessories. The BURNDY® YCUT129ACSR is provided with a 5-year limited warranty (excluding blades).



#### SPECIFICATIONS

Force Developed: 7 U.S. short tons  
 Tool Weight: 11.4 lbs. (5.1 kg)  
 Length: 22.4" (56.9 cm)  
 Width: 2.5" (6.4 cm)  
 Height: 6.6" (16.8 cm)

#### FOR USE ON

- Copper Cable: up to 1.29"
- Aluminum Cable: up to 1.29"
- ACSR: up to 1113 ACSR
- Ground Rod: up to 5/8"
- Rebar: up to 1/2"
- Soft Steel Bolts: up to 5/8"
- Standard Guy Strand: up to 1/2"
- EHS Guy Strand: up to 3/8"

#### ACCESSORIES

- Carrying Case: Cat# PT10024162
- Replacement Blades:
  - Cat# PT10037388 (Moving Blade)
  - Cat# PT10037384 (Fixed Blade)

#### Features and Benefits

- Patented rapid advance pump.
  - ◇ Faster cuts with less hand strokes.
- Specialized latch head design.
  - ◇ Interference free closure on mid-span cuts.
- Handle trigger drain
  - ◇ For convenient blade retraction.
- Hardened steel blades.
  - ◇ Ability to cut ACSR, ground rods, rebar and guy wire.
- Comfort grip handles.
  - ◇ Help ease fatigue with continuous use.
- 180-degree head rotation.
  - ◇ Versatile head positioning to get into tight areas easier.
- Durable high impact formed carrying case.
  - ◇ Provides tool protection and stores accessories.
- 5-year limited warranty on tool (excluding blades).
  - ◇ Customer satisfaction and support.

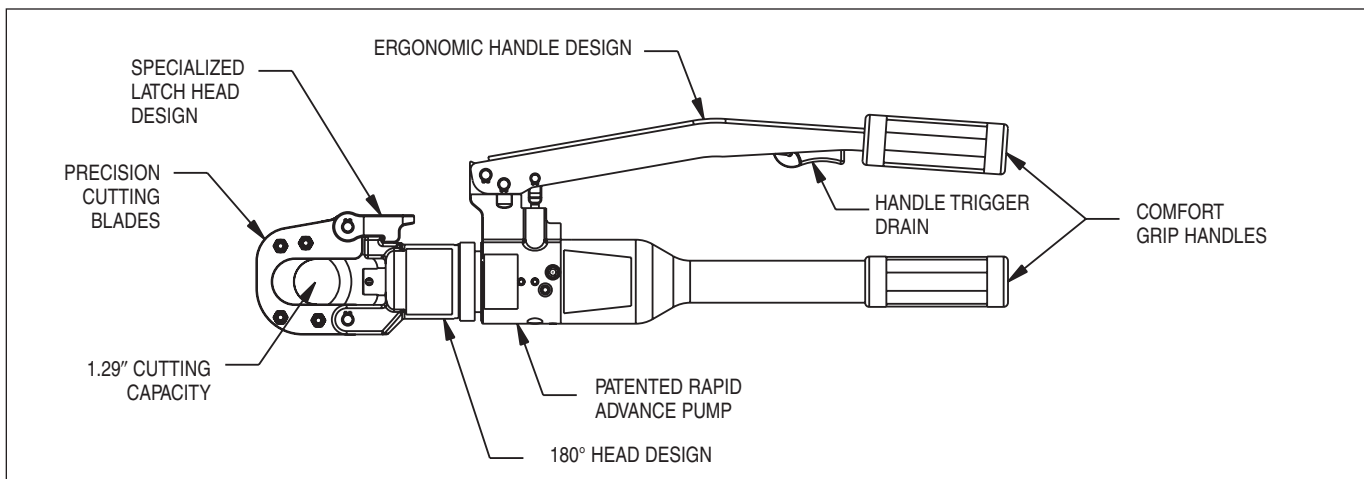



### TYPE PATRIOT® PAT750XT-18V

#### BATTERY ACTUATED TOOL

#### Hydraulic Self-Contained 12 Ton Crimping Tool

The BURNDY® PATRIOT® can be operated with only one hand, making them the only true, one-handed battery powered crimping and cutting tools available in the world today.

The BURNDY® PATRIOT® PAT750XT-18V incorporated the latest engineering technology with the patented high speed hydraulic pump. Our battery actuated hydraulic tool provides a consistent, reliable connection every time. The PAT750XT-18V features BURNDY's Y750 tool head, capable of using all "U" style dies, and incorporates a patent pending bearing and alignment guide for use on HYGROUND™ and other asymmetrical connectors. Features reliable head rotation design for operation in virtually any position.

Each PATRIOT® uses standard BURNDY® dies and off-the-shelf connectors available world-wide. Supplied with a durable high impact formed carrying case to hold the tool, battery charger, two batteries, tool retention lanyard, and die compartment to hold "U" die sets. (Dies sold separately.) All BURNDY® PATRIOT® 18V series tools are provided with a 5 year limited warranty.



#### Features

- True, one-handed operation for advance, retract, and hold.
- 12 ton output force.
- State of the art crimping head design, 360° head rotation.
- Ergonomically balanced tool design.
- Durable High Impact Formed carrying case.
- PAT750XT-18V – with rubber covered head is available.
- 18 volt Ni-MH battery eliminates voltage depression (memory issues).
- 5 year limited warranty on tool. 1 year warranty on battery and charger.

#### SPECIFICATIONS

<b>Output Force:</b>	12 tons (10.9 metric tons)
<b>Tool Weight:</b>	16.5 lbs (7.5 kg) With Battery
<b>Length:</b>	15.75" (40 cm)
<b>Height:</b>	13.5" (34.29 cm)
<b>Width:</b>	3.5" (8.89 cm)
<b>Operating Voltage:</b>	18V-DC
<b>Battery Recharge Time:</b>	<45 minutes

#### FOR USE ON

- **Tension Sleeves**
  - Copper #9 sol. - 500 kcmil
  - Aluminum #8 sol. - 587.2 kcmil
  - ACSR #4 - 556.5 kcmil
- **Taps**
  - Copper #14 sol. - 500 kcmil
  - Aluminum #8 - 500 kcmil
- **Aerial Cable**
  - Copper #6 - 500 kcmil
- **Terminals & Splices**
  - Aluminum #8 - 750 kcmil
  - Copper #8 - 750 kcmil
  - ACSR #4 - 556 kcmil
- **HYGROUND™**
  - Copper #8 - 500 kcmil (cable/ground rod)
  - Ground Rods 1/2" - 1" Diameter

#### ACCESSORIES

- **Battery:** Cat# **BAT18V**  
Hi Capacity Ni-MH (2.6 AH)
- **Charger:**
  - 120V-AC Cat# **PATCHGR-18V**
  - 12/240V-DC Cat# **BCT/PATDCCHGR**
  - 240/250V-AC Cat# **PATCHGR250V**
- **Lanyard** Cat# **PT208620**

#### Benefits

- Easier tool operation.
- Versatile tool head positioning lets user get into tight areas easier.
- Allows use of standard BURNDY® dies already in use.
- Less "down-time" due to high capacity, high voltage 18 volt battery.
- Ergonomically balanced tool eases operation and helps lessen fatigue.
- Smoother, quieter, more efficient tool operation.
- Durable high impact formed case provide superior protection and stores all accessories.

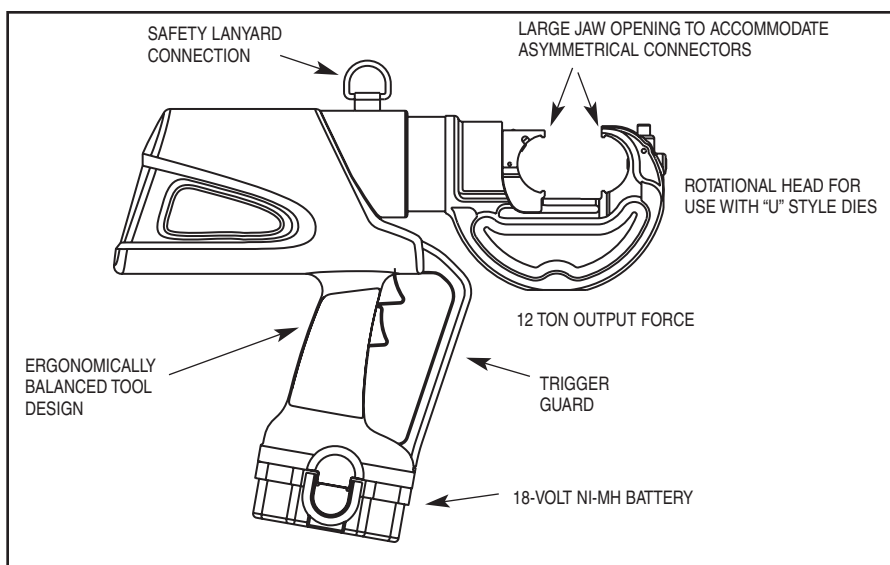



### TYPE PATRIOT® PAT644-18V

#### BATTERY ACTUATED TOOL – Hydraulic Self-Contained – 11 Ton

The BURNDY® PATRIOT® series of battery actuated tools can be operated with only one hand, which allows the other hand to be free to position the connector and conductor prior to crimping.

The BURNDY® PATRIOT® PAT644-18V incorporates the latest engineering technology with patent pending pump, transmission and piston component designs. Our self-contained hydraulic tool provides a consistent, reliable connection every time. The PAT644-18V features BURNDY's Y644 dieless latch head tool which eliminates the need to purchase and maintain dies. Features reliable head rotation design for operation in virtually any position.

Each PATRIOT® uses standard BURNDY® off-the-shelf connectors available worldwide. Supplied with a durable high impact formed carrying case to hold the tool, battery charger, two batteries, and tool retention lanyard. All BURNDY® PATOOL™ 18V series tools are provided with a 5-year limited warranty.

**PAT644-18V Range Taking Capabilities:**  
Please refer to the individual connector pages for detailed information on the PAT644-18V range taking capabilities.



#### FEATURES

- Dieless system.
- True, one-handed operation for advance, retract, and hold.
- 11-ton output force.
- State of the art crimping head design, 360° head rotation.
- Audible “pop-off” and Green indicator indicates properly completed crimps.
- Ergonomically balanced tool design.
- Durable High Impact Formed carrying case.
- Ni-MH battery eliminates voltage depression (memory issues).
- 5-year limited warranty on tool. 1-year warranty on batteries and charger.

#### SPECIFICATIONS

Crimp Force:	11 Tons (10.9 metric tons)
Tool Weight:	17 lbs (7.7 kg)
Length:	15-1/2" (39.37 cm)
Width:	3-1/2" (8.89 cm)
Height:	13-7/8" (35.24 cm)
Operating Voltage:	18 V-DC
Recharge Time:	< 45 mins.

#### FOR USE ON

AWG/KCMIL WIRE SIZE RANGE	CONNECTOR TYPES
Copper #6 - 1000 kcmil	Terminals YA-L, YA-2LN, YA, YA-2N, YA-L-2TC, YAB-4N, YA-L-TC, YA-2L, YA-4N Splices YS-L, YS, YS-T
Aluminum #6 - 750 kcmil	Terminals YA-A, YA-A-TN Splices YS-A
Aluminum #6 - 750 kcmil	HYPLUG™ AYP, AYPO

#### ACCESSORIES

- **Battery:**  
Hi-capacity Ni-MH  
(2200 mA-hr) Cat# **BAT18V**
- **Charger:**  
120V-AC Cat# **BATCHGR-18V**  
12/24V-DC Cat# **BCT/PATDCCHGR**
- **Lanyard:** Cat# **PT208620**

#### BENEFITS

- Eliminates the need to purchase and maintain dies.
- Easier tool operation.
- Versatile tool head positioning lets user get into tight areas easier.
- Less “down-time” due to high capacity, high voltage 18 volt battery.
- Assures proper crimps with both audible and visual indicators, leaving no doubt for the tool user.
- Ergonomically balanced tool eases operation and helps lessen fatigue.
- Smoother, quieter, more efficient tool operation.
- Durable high impact formed case provides superior protection and stores all accessories.

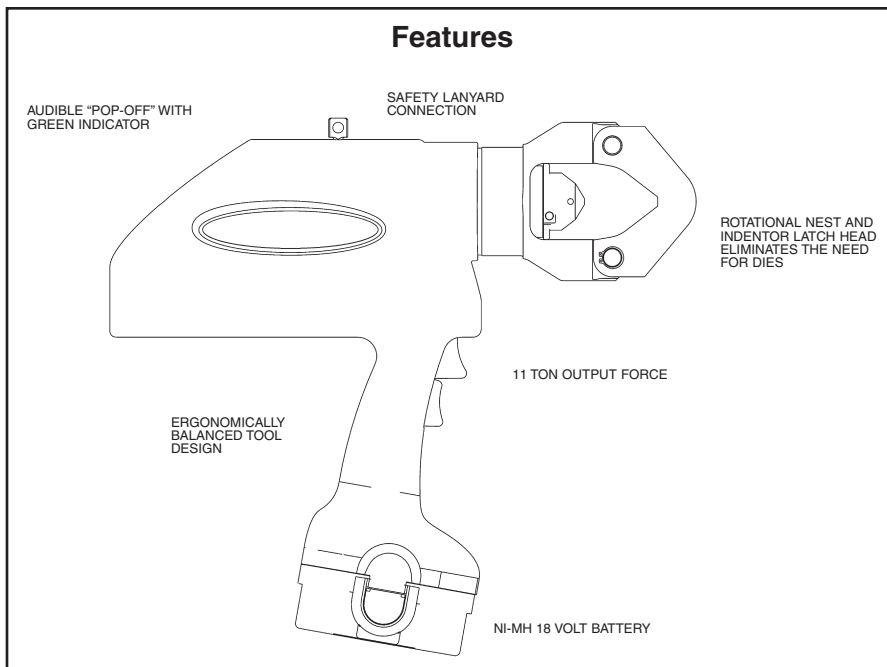

### TYPE 4-POINT™ PATRIOT® PAT81KFT-18V

#### BATTERY ACTUATED TOOL

Hydraulic Self-Contained  
Crimping Tool

#8-1000 KCMIL COPPER HYLUG™  
TERMINALS and HYLINK™ SPLICES

#8-750 KCMIL ALUMINUM HYLUG™  
TERMINALS and HYLINK™ SPLICES

The BURNDY® PAT81KFT-18V is a battery powered crimping tool that provides a powerful 6 tons of crimping force. It is compact, fast, easy to use and incorporates the latest in battery tool technology. The ergonomic design allows for one hand operation so that the other is free to position the connectors and conductor prior to crimping. The PAT81KFT-18V features a dieless latch head design which eliminates the need to purchase and maintain dies. Featuring 360° head rotation, the PAT81KFT-18V is designed for easy operation in virtually any position.

The PAT81KFT-18V is supplied with a high impact carrying case, battery charger, lanyard and two batteries. The PAT81KFT-18V comes complete with a 5-year limited warranty on the tool and 1 year limited warranty on the batteries.

PAT81KFT-18V Dieless HYPRESS™ Range Taking Capabilities: The PAT81KFT-18V provides range taking capabilities that is UL and CSA listed for Copper (Code, Compact and Flex) and Aluminum (Code and Compact) conductors when used in conjunction with BURNDY® HYLUG™ terminals and HYLINK™ splices. See chart for connector, conductor and range taking combinations.



#### Features and Benefits

- Dieless installation system.
  - ◇ Eliminates the need to purchase and maintain dies.
- UL Listed and CSA Certified with Range Taking Capabilities
  - ◇ Provides the installer with UL Listed and CSA Certified crimps with Range Taking Capabilities when used in conjunction with BURNDY® HYLUG™ Terminals and HYLINK™ Splices
- Audible pressure “pop-off” valve and die embossment providing 360° inspectability.
  - ◇ Assures proper crimps with both audible and visual indicators for the installer.
- Battery powered crimp technology.
  - ◇ Easy Tool Operation and portability.
- Advanced high speed pump design.
  - ◇ Provides faster crimps, longer life, efficiency, and reliability.
- Ergonomic design allows one hand operation for ram advance and ram retraction.
  - ◇ User always has one hand free to manipulate connector and conductor.
- 360 Degree head rotation.
  - ◇ Versatile tool head positioning lets the user get into tight areas easier.
- Ram holds position when trigger is released.
  - ◇ Provides the ability to hold the connector between the indentors and check for alignment prior to crimping action.

#### SPECIFICATIONS

<b>Output Force:</b>	6 tons (5.4 Metric Tons)
<b>Weight:</b>	14 lbs (6.35 kg)
<b>Length:</b>	17.6 (447 mm)
<b>Height:</b>	13.9 in (354 mm)
<b>Width:</b>	3.7 in (94 mm)
<b>Operating Voltage:</b>	18V-DC
<b>Battery Recharge Time:</b>	<45 Mins

#### FOR USE ON

- Copper, Aluminum, Compressed, Compact, Stranded, Solid and Flex Conductors.
- Installs Splices, Taps and Terminations:
  - #8 - 1000 kcmil Copper (YA, YA-L, YS, YS-L, YS-T, Y-R )
  - #8 - 777.7 (750 Nominal Flex Wire Size) kcmil Flex (YA-FX, YAV, YA-L-FX, YS, YSV-FXB)
  - #8 - 750 kcmil Aluminum (YA-A, YS-A)
  - #8 - 750 kcmil Aluminium Pin Adapters (AYP, AYPO)

#### ACCESSORIES

- **Battery:** Cat# **BAT18V**  
Hi Capacity Ni-MH (2200 mA-hr)
- **Charger:** Cat# **BATCHGR-18V**  
120V-AC Cat# **BCT/PATDCCHGR**  
12/240V-DC
- **Lanyard** Cat# **PT208620**
- Mechanical ram release.
  - ◇ Reliable ram release (no battery consumption).
- Uses 18 volt Ni-MH batteries.
  - ◇ Eliminates voltage depression or “memory”.
- Audible pressure “pop-off” value.
  - ◇ Indicates properly completed crimps.
- Durable high impact formed carrying case.
  - ◇ Provides tool protection and stores all accessories.
- 5-year limited warranty on tool, 1 year on batteries and charger.
  - ◇ Customer satisfaction and support.

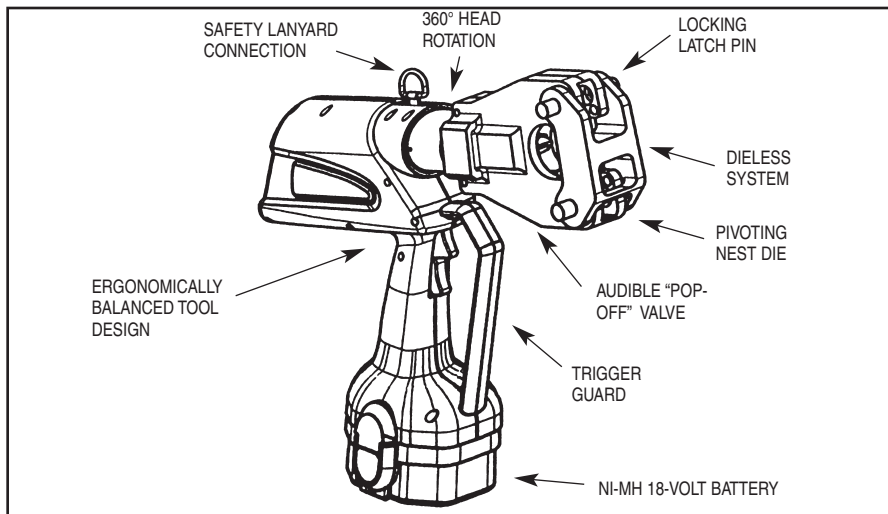

### TYPE PATRIOT® IN-LINE™ PATMD6-14V Series

#### Battery Actuated Tool— Hydraulic Self Contained— 6 Ton

The BURNDY® IN-LINE™ tools are battery actuated and can be operated with one hand allowing for advance, retract and hold functions for easier operation. One hand operation allows the operator one free hand to position the connector and conductor while crimping. The PATRIOT® PATMD6-14V series of tools incorporate a high speed hydraulic pump generating 6 tons of crimping force. This design provides a consistent, reliable connection every time.

The IN-LINE™ tool features interchangeable MD6 series heads, capable of using “W” and “X” style dies in the permanent D3 groove. When ordering choose the tool that best suits your crimping needs. The IN-LINE™ tools feature 350° rotatable heads for operation in virtually any position

Each PATRIOT® IN-LINE™ tool uses standard BURNDY® dies and off-the-shelf connectors available world-wide. IN-LINE™ tools are supplied with a durable high impact formed carrying case, battery charger, two batteries, and die compartment to hold dies. (Dies are sold separately.) All BURNDY® IN-LINE™ tools are provided with a 3-year limited warranty.

#### PATRIOT® IN-LINE™ VARIATIONS

- PATMD6-14V** Permanent “BG” (5/8”) and “D3” grooves.
- PATMD6-8-14V** Permanent “O” and “D3” grooves.
- PATMD6-6-14V** “Snub-Nose” version with permanent “D3” groove.



#### Features and Benefits

- True, one-handed operation for advance, retract, and hold.
- 6 ton output force for reliable compression connections.
- Pressure “pop-off” valve indicates completion of crimp
- Interchangeable scissor action crimp jaws allow easier access to tight spaces.
- Ram holds position when trigger is released to allow the operator to check alignment prior to crimping.
- Allows the use of standard Burndy “W” and “X” dies already in use.
- Large hand grip area allows easier operation with gloves
- Ergonomically balanced tool design helps lessen operator fatigue.
- Durable high impact formed carrying case.
- High capacity 2.6 AH batteries provide more crimps per charge.
- 14.4 volt Ni-MH battery eliminates voltage depression (memory issues).
- 3-year limited warranty on tool.
- 1-year warranty on batteries and charger.

#### SPECIFICATIONS

- Output force:** 6 tons (5.4 metric tons)
- Tool Weight:** 7.8 lbs (3.5 kg) With Battery
- Length:** 20.91” (53.11 cm)
- Width:** 3.69” (9.37 cm)
- Height:** 5.48” (13.91 cm)
- Operating Voltage:** 14.4 V-DC
- Recharge Time:** < 45 minutes

#### FOR USE ON

- Copper, Aluminum, ACSR. Steel, Copperweld, Alumoweld, 6201, 5005, Compressed, and Compact conductors
- Copper Taps: #10 solid - 2/0 stranded
- Aluminum and ACSR Taps: #14 solid - 4/0 ACSR
- Stirrups: #6 - 4/0 ACSR
- Overhead Full Tension Deadends, Full Tension Splices and Terminals #10 str. - 4/0 ACSR
- Installs splices, taps or terminations:
  - #8 - 500 kcmil Copper Str. (YA, YA-L, YS, YS-L)
  - #8 - 350 kcmil flex
  - #8 - 350 kcmil Aluminum (YA-A, & YS-A)

#### ACCESSORIES

**Battery:** Cat# **BAT14V** (2.6 AH)  
Hi-capacity Ni-MH

**Chargers:**  
120V-AC Cat# **PATCHGR18V**  
12/24V-DC Cat# **BCT/PATDCCHGR**  
240/250V-AC Cat# **PATCHGR250V**

**Cutter Dies:** Cat# **W28K**  
For cutting #4 -4/0 Copper, Aluminum & ACSR

**Interchangeable Jaw Assemblies:**  
“BG” and “D3” Grooves **PATJAWSMD6**  
“O” and “D3” Grooves **PATJAWSMD6-8**  
D3 Only (“Snub-Nose”) **PATJAWSMD6-6**

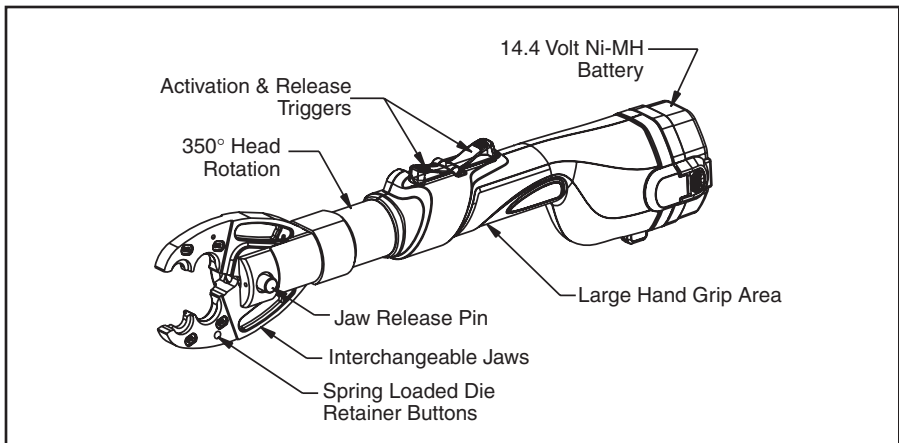

### TYPE PATRIOT® PAT600-18V

#### BATTERY ACTUATED TOOL – Hydraulic Self-Contained – 6 Ton

The BURNDY® PAT600-18V battery powered crimping tool provides a powerful 6 tons of crimping force and completes a crimp in approximately 3 seconds. The PAT600-18V is compact, easy to use and incorporates the latest in battery tool technology. The PAT600-18V tool incorporates a specialized latch style head with enhanced working stroke and clearance capabilities. The specialized head allows interference-free closure on tap connections up to the BURNDY® YHD-400 size including 350 kcmil aluminum connectors. Die selection with this tool includes all BURNDY® “W” and “W-VT” style dies which seat in the permanent “D<sub>3</sub>” crimping groove. Installation applications include #8 AWG to 600 kcmil copper lugs and splices, #8 AWG to 350 kcmil aluminum lugs and splices (YA-A and YS-A), and up to 4/0 aluminum tap connections. The permanent “D<sub>3</sub>” groove and 180 degree rotatable head are standard on the PAT600-18V.

Each PAT600-18V tool uses BURNDY® dies and off-the-shelf connectors available worldwide. The PAT600-18V comes equipped with a high impact formed carrying case to hold the tool, a battery charger and two batteries. The case houses up to 10 “W” dies (dies purchased separately). The PAT600-18V uses industry standard batteries and chargers. The PAT600-18V comes complete with a 5-year limited warranty and one year on batteries and charger.



#### Features and Benefits

- Battery powered crimp technology.
  - ◇ Easy tool operation and portability.
- Advance design high speed pump completes crimp in approximately 3 seconds.
  - ◇ Longer life, efficiency, and reliability.
- Ergonomic design allows one hand operation for ram advance and ram retraction.
  - ◇ User always has one hand free to manipulate connector and conductor.
- Variable speed trigger.
  - ◇ Provides flexibility in speed of ram advance.
- Ram holds position when trigger is released.
  - ◇ Provides ability to hold the connector between dies and check for proper alignment prior to crimping action.
- Mechanical ram release.
  - ◇ Reliable ram release (no battery power consumption).
- Specialized latch head design.
  - ◇ Provides enhanced clearance on tap connectors when compared with competitive designs.

#### SPECIFICATIONS

Crimp Force:	6 Tons (US) (5.4 metric tons)
Tool Weight:	10.9 lbs (4.9 kg)
Length:	14.5" (36.8 cm)
Width:	3.5" (8.9 cm)
Height:	13.75" (34.9 cm)
Operating Voltage:	18 V-DC
Crimp Time:	Approx. 3 seconds
Recharge Time:	< 45 mins.

#### FOR USE ON

- Copper, Aluminum, ACSR, Steel, Copperweld, Alumoweld, 6201, 5005, Compressed, Compact, Stranded & Solid
- Installs splices, taps, or terminations:
  - #8 - 600 kcmil Copper Str. (YA, YA-L, YS, YS-L)
  - #8 - 350 kcmil Flex
  - #8 - 350 kcmil Aluminum (YA-A & YS-A)

#### ACCESSORIES

• Lanyard:	Cat# PT208620
• W Die Holder	Cat# WDIETREE
• Battery:	
Hi-capacity	Cat# BAT18V
(2200 mA-hr)	
• Battery with LED light:	
(3000 mA-hr)	Cat# BAT18VLED
• Charger:	
120V-AC	Cat# PATCHGR18V
12/24V-DC	Cat# BCT/PATDCCHGR
240/250V-AC	Cat# PATCHGR250V

- 180 degree head rotation.
  - ◇ Versatile tool head positioning lets user get into tight areas easier.
- Uses 18 volt Ni-MH batteries.
  - ◇ Eliminates voltage depression or “memory”.
- Audible pressure “pop-off” valve.
  - ◇ Indicates properly completed crimp.
- Permanent D<sub>3</sub> crimp groove accepts all “W-Dies”.
  - ◇ Uses standard die design with proven performance.
- PAT600C-18V with covered head is available.
  - ◇ Covered head for impact protection.
- Durable high impact formed carrying case.
  - ◇ Provides tool protection and stores all accessories.
- 5-year limited warranty on tool, 1 year on batteries and charger.
  - ◇ Customer satisfaction and support.

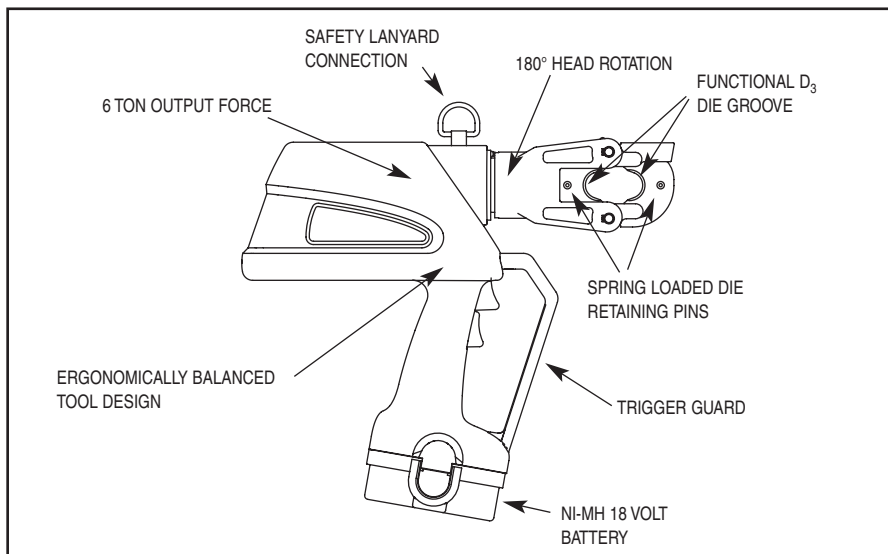

### TYPE PATRIOT™ PATCUT129ACSR-18V

#### BATTERY ACTUATED TOOL – Hydraulic Self-Contained – Cutter

The BURNDY® PATCUT129ACSR-18V battery powered cutting tool is compact, fast, easy to use and incorporates the latest in battery tool technology. The ergonomic design allows one hand operation so that the other is free to manipulate the conductor in the proper cutting position. The PATCUT129ACSR-18V incorporates a specialized latch style cutting head that allows interference-free closure for mid-span cuts. The cutter head rotates 180 degrees to allow users to get into tight areas easier. The PATCUT129ACSR-18V is capable of cutting up to 1.29" diameter copper and aluminum cable, 1113 ACSR, 5/8" ground rod, 1/2" rebar, 5/8" diameter soft steel bolts, up to 1/2" standard guy strand, and up to 3/8" EHS guy strand.

The PATCUT129ACSR-18V operates on industry standard 18-volt Ni/MH batteries that eliminate voltage depression or "memory" issues. The PATCUT129ACSR-18V comes equipped with a high impact formed carrying case to hold the tool, a tool retention lanyard, a battery charger and two batteries. The PATCUT129ACSR-18V is provided with a 5-year limited warranty (excluding blades), and 1-year on batteries and charger.

Made in the USA.



#### Features and Benefits

- Battery powered cutting technology.
  - ◇ Easy tool operation and portability.
- Advance design high-speed pump completes tough cuts faster.
  - ◇ Longer life, efficiency, and reliability.
- Specialized latch head design.
  - ◇ Interference free closure for mid-span cuts.
- Ergonomic design allows one hand operation.
  - ◇ User has one hand free to manipulate material to be cut.
- 180 degree head rotation.
  - ◇ Versatile head positioning allows user to get into tight areas easier.
- Mechanical ram release.
  - ◇ Reliable ram release (no battery power consumption).
- Operates on 18 volt Ni-MH batteries.
  - ◇ Eliminates voltage depression or "memory" issues.
- Durable high impact formed carrying case.
  - ◇ Provides tool protection and stores all accessories.
- 5-year limited warranty on tool (excluding blades) and 1 year on batteries and charger.
  - ◇ Customer satisfaction and support.

#### SPECIFICATIONS

Tool Weight: 11 lbs.  
 Length: 14.5"  
 Width: 3.5"  
 Height: 13.5"  
 Operating Voltage: 18 V-DC  
 Recharge Time: < 45 mins.

#### FOR USE ON

- Copper Cable: up to 1.29"
- Aluminum Cable: up to 1.29"
- ACSR: up to 1113 ACSR
- Ground Rod: up to 5/8"
- Rebar: up to 1/2"
- Soft Steel Bolts: up to 5/8"
- Standard Guy Strand: up to 1/2"
- EHS Guy Strand: up to 3/8"

#### ACCESSORIES

- **Lanyard:** Cat# PT208620
- **Battery:** Hi-capacity Cat# BAT18V (2200 mA-hr)
- **Battery with LED light:** (3000 mA-hr) Cat# BAT18VLED
- **Charger:** 120V-AC Cat# PATCHGR18V  
 12/24V-DC Cat# BCT/PATDCCHGR  
 240/250V-AC Cat# PATCHGR250V
- **Replacement Blades:** Cat# PT10037388 (Moving Blade)  
 Cat# PT10037384 (Fixed Blade)

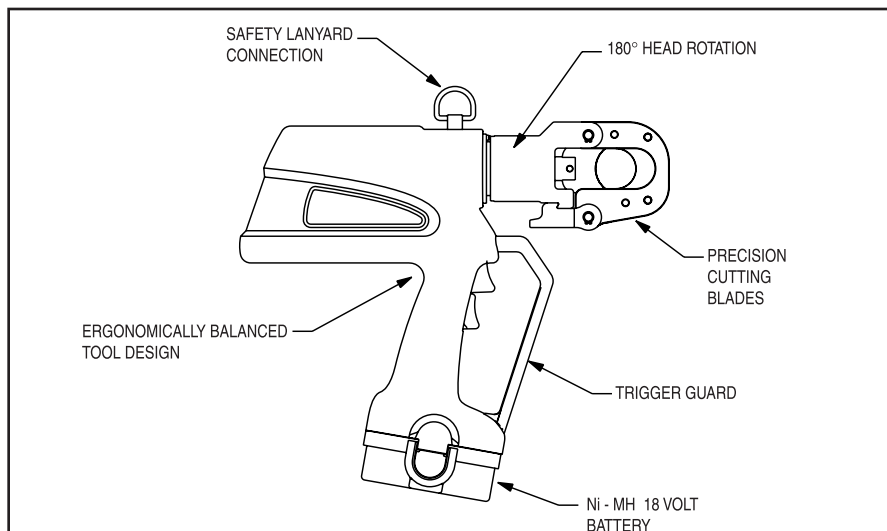



### PATRIOT® PATCUT245CUAL-18V

#### BATTERY ACTUATED TOOL – Hydraulic Self Contained Cutter

The BURNDY® PATCUT245CUAL-18V battery powered cutting tool is compact, fast, easy to use and incorporates the latest in battery tool technology. The ergonomic design allows one hand operation so that the other is free to manipulate the conductor in the proper cutting position. The PATCUT245CUAL-18V incorporates a specialized latch style cutting head that allows interference-free closure for mid-span cuts. The cutter head rotates 180 degrees to allow users to get into tight areas easier. The PATCUT245CUAL-18V is capable of cutting up to 2.45" diameter copper and aluminum cable.

The PATCUT245CUAL-18V operates on industry standard 18-volt Ni/MH batteries that eliminate voltage depression or "memory" issues. The PATCUT245CUAL-18V comes equipped with a high impact formed carrying case to hold the tool, a tool retention lanyard, a battery charger and two batteries. The PATCUT245CUAL-18V is provided with a 5-year limited warranty (excluding blades), and 1-year on batteries and charger.



#### Features and Benefits

- Battery powered cutting technology.
  - ◇ Easy tool operation and portability.
- Advance design high-speed pump completes tough cuts faster.
  - ◇ Longer life, efficiency, and reliability.
- Specialized latch head design.
  - ◇ Interference free closure for mid-span cuts.
- Ergonomic design allows one hand operation.
  - ◇ User has one hand free to manipulate material to be cut.
- 180-degree head rotation.
  - ◇ Versatile head positioning allows user to get into tight areas easier.
- Mechanical ram release.
  - ◇ Reliable ram release (no battery power consumption).
- Operates on 18-volt Ni/MH batteries.
  - ◇ Eliminates voltage depression or "memory" issues.
- Durable high impact formed carrying case.
  - ◇ Provides tool protection and stores all accessories.
- 5-year limited warranty on tool (excluding blades) and 1-year on batteries and charger.
  - ◇ Customer satisfaction and support.

#### SPECIFICATIONS

Tool Weight:	14.5 lbs (5.4 kg)
	With Battery
Length:	18" (45.7 cm)
Width:	3.75" (9.5 cm)
Height:	14.75" (37.5 cm)
Operating Voltage:	18 V-DC
Recharge Time:	< 45 mins.

#### FOR USE ON

Copper and	Up to 2.45" O.D
Aluminum Cable:	(62.2 mm)

**FOR COPPER AND ALUMINUM CABLE ONLY. DO NOT CUT STEEL, GROUND ROD, REBAR, OR GUY WIRE.**

#### ACCESSORIES

- **Carrying Case:** Cat# **PT10044980**
- **Lanyard:** Cat# **PT208620**
- **Battery:** Hi-capacity Cat# **BAT18V** (2200 mA-hr)
- **Battery with LED light:** (3000 mA-hr) Cat# **BAT18VLED**
- **Charger:** 120V-AC Cat# **PATCHGR18V**  
12/24V-DC Cat# **BCT/PATDCCHGR**  
240/250V-AC Cat# **PATCHGR250V**
- **Replacement Blades:** Cat# **PT10038657** (Moving Blade)  
Cat# **PT10040663** (Fixed Blade)

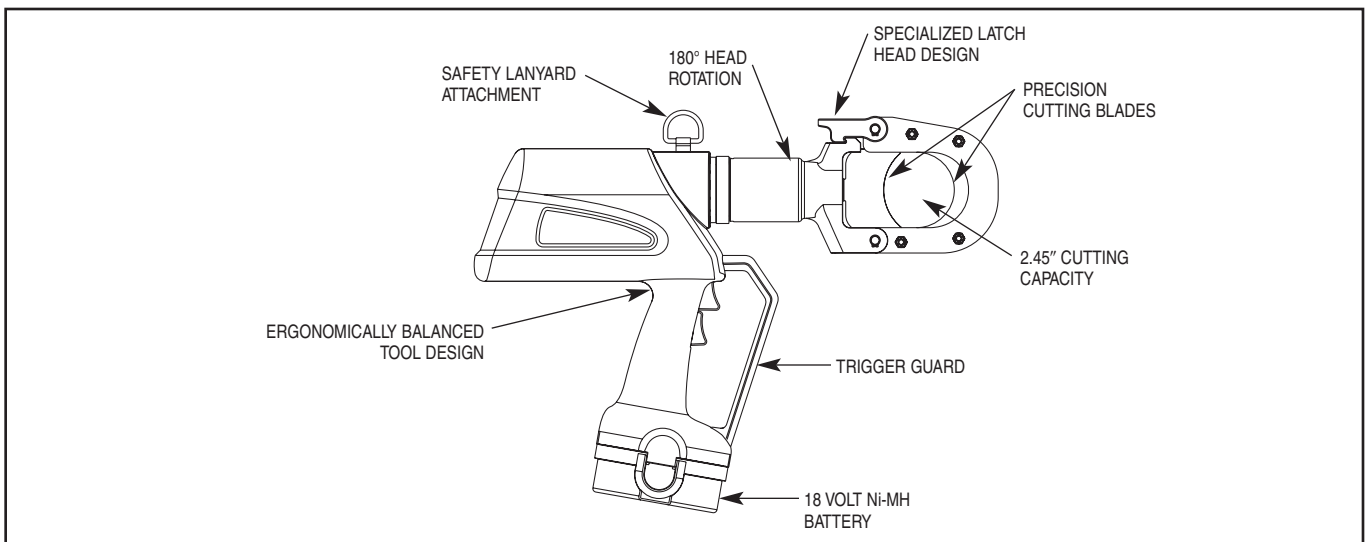

### TYPE BCC1000CUAL

#### BATTERY ACTUATED CABLE CUTTER

The BURNDY® BCC1000CUAL is a 12-V-DC battery actuated cable cutter capable of cutting up to 750 kcmil hard drawn copper cable, and up to 1000 kcmil soft drawn copper and up to 2" O.D. aluminum cable. DO NOT CUT STEEL or ACSR. The BCC1000CUAL comes with battery powered cutting tool, sealed nickel cadmium 12V battery, 120V AC charger, carrying case, and wrist loop which provides added security when making cuts overhead.

The BURNDY® BCC1000CUAL is designed to cut copper and aluminum cables in a limited amount of space. The BCC1000CUAL makes fast reliable cuts without stress to the user. Just squeeze the trigger and it will cut through your toughest copper and aluminum cables. The BCC1000CUAL has a three-way switch (forward, reverse, and neutral) which allows the user to make partial cuts, back off cables, or make adjustments during cutting.

The battery charge time is approximately 1 hour for a fast charge (80%), 4 to 6 hours for a quick charge, and 14 to 16 hours for a standard charge (100%). The 12V battery can be recharged approximately 1,000 times.

The BCC1000CUAL (excluding cutting blades) is warranted to be free of defects in material and workmanship for a period of 90 days, except in the case of abuse or modification.

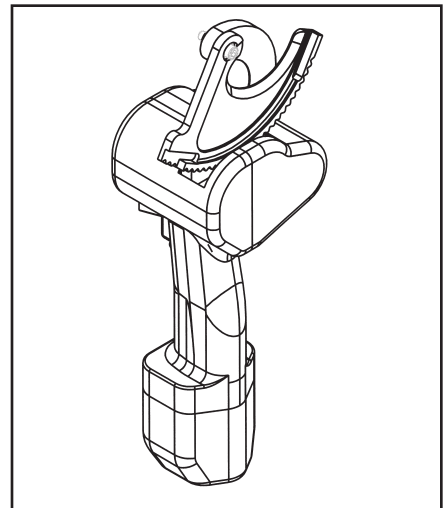

#### FEATURES

- Hook head design.
- Three way switch.
- Hardened steel blades.
- Ergonomic design.
- Wrist loop.

#### BENEFITS

- Simplifies conductor cutting and allows working in tight spaces.
- Allows backing off cable, partial cuts, and adjusting during cutting.
- Helps ensure consistent cuts and longer blade life.
- Prevents hand/wrist injury.
- Withstands rugged use. Resists oil and solvents.
- Added security when cutting cables overhead.

#### SPECIFICATIONS

Specifications	Description
<b>Cutting Tool:</b>	
Drive Unit:	12.0V DC Motor
Dimensions:	4" L × 4.5" W × 14.5" H
Weight:	6 lb
Cutting Capacity:	1000 kcmil soft drawn copper, 750 kcmil hard drawn copper and up to 2" O.D. aluminum
<b>Battery:</b>	
Battery Type:	Sealed nickel cadmium
Voltage:	12.0V DC
Rated Capacity:	1.2A/hr
Charge Time:	Fast, approx. 1 hour Quick, 4-6 hours Standard, 14-16 hours
Dimensions:	2.75" L × 2.7" W × 4.75" H
Weight:	1.4 lb
<b>Battery Charger:</b>	
Input Voltage:	120V AC
Input Frequency:	60 Hz
Input Current:	110/120V
Dimensions:	5.7" L × 3" W × 2.8" H
Weight:	2.2 lb

#### FOR USE ON

Maximum conductors accommodated:

- 750 kcmil hard drawn copper
- 1000 kcmil soft drawn copper
- 1000 kcmil aluminum

#### ACCESSORIES

Catalog Number	Item Description
<b>BCCBAT12V</b>	BCC1000CUAL Battery
<b>BCCCHGR</b>	BCC1000CUAL Charger
<b>BCCCASE</b>	BCC1000CUAL Carrying Case
<b>RP50RP03</b>	BCC1000CUAL Moving Blade
<b>RP50RP02</b>	BCC1000CUAL Fixed Blade



### TYPE Y700DC-1B

#### Y-DC BATTERY POWERED HYDRAULIC PUMP

HYDRAULIC OUTPUT PRESSURE OF:  
10,000 PSI

The lightweight, portable, battery powered hydraulic pump unit for use with almost all BURNDY® HYPRESS™ remote tool heads and cutters. The pump will provide approximately 30 operations before requiring a recharge of the batteries, which can be recharged in under 15 minutes, utilizing the rapid charger provided. The high capacity 12 VDC batteries and charging system will allow 1,000 charge/discharge cycles per battery providing more than double the life of other batteries. The pump is supplied with a dielectric grade 6' long hydraulic hose, 1 rapid battery charger, and 2 rechargeable batteries. Also included is an air-bulb control switch that allows remote operation of the pump, or users may opt for the built-in switch to operate the unit. The Y700DC-1B provides consistent, reliable compression connections due to the factory-set "pop-off" pressure relief valve. The full automatic operation allows the operator to control functions such as "Advance", "Hold", and "Retract" at will, truly making the Y700DC-1B a versatile, go-anywhere pump unit.



#### FEATURES

- Lightweight, easy to carry.
- Two modes of operation.
- Transparent reservoir.
- Charged/Low battery indicator.
- Rapid battery recharger (less than 15 mins.).
- Allows use of wide range of remote tool heads and cutters.
- 5-year limited warranty on tool and 1-year on batteries and chargers.

#### BENEFITS

- Lightweight and easy to lift, carry, and transport to/around job site.
- Advance and hold feature permits final inspection before completing crimp cycle.
- Transparent reservoir allows viewing for daily checking of fluid level.

#### SPECIFICATIONS

##### MOTOR

Type: Electric (12V-DC)  
Power Source: 12V-DC batteries (2)

Max Output: 280 watt

Max Draw: 35 amp

##### PUMP

Operating PSI: Low-0.98 Mpa  
High -68.6 + 3.4 Mpa

Hydraulic Fluid: BURNDY® ALFLUID™

Control Type: Air-bulb or switch

##### COMPLETE UNIT

##### DIMENSIONS

Weight: 15-1/2 lbs. with fluid and two batteries

Height: 11.5"

Width: 8.25"

Depth: 6.5"

#### FOR USE ON

##### Battery

Pump	Psi	Tools and Cutters
Y700DC-1B	10,000	Y34BH, Y35BH, Y35BH-4, Y39BH, Y75OBH, Y75OBH-2, Y644MBH, Y45, Y45-1, Y46, Y46-C, RHCC Series Cutters

#### ACCESSORIES

- Steel Carry Case: Cat# **YDC-CASE** Holds pump (w/2 batteries), Charger, 6' Hose, and air-bulb control
- Batteries: Cat# **BAT12B**
- Charger: Cat# **BATCHGR**

#### BENEFITS (Continued)

- Choice of operation method with either mounted switch or remote air-bulb control devices.
- Unit allows operation with only 1 battery while the other recharging the other.
- Built-in device prevents operation when batteries have insufficient power to complete crimping cycle.
- Able to operate in remote locations without electric power source.

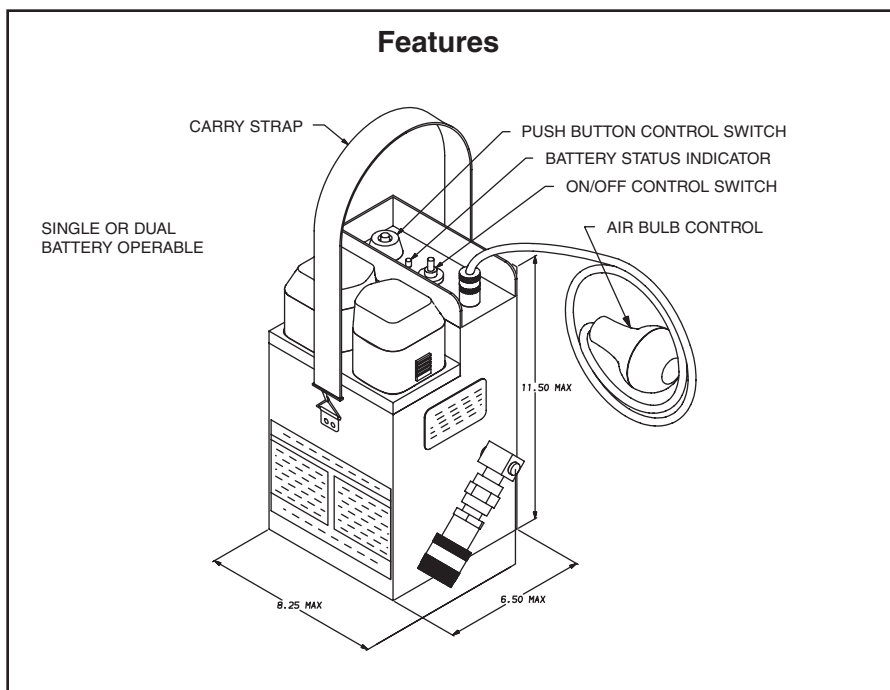

### TYPE Y35BH HYPRESS™ 10,000 PSI

#### REMOTE POWER OPERATED COMPRESSION TOOLS

The Y35BH...series remote head is designed for remote power operation and incorporates the same C-shaped head as the Y35. The hook style head with extensive ram travel provides for easy tapping and splicing of overhead lines as well as HYGROUNDTM compression grounding systems.

The remote power operated Y35 heads are available covered with 3/16" molded rubber cover for tool impact protection.

Order head, hose, pump, dies and accessories separately. Five-year limited warranty.



#### BENEFITS

- Easy tool removal from line conductor after compression taps are installed with the open "C" shaped head.
- Easily lifted into working position using the lifting eye.
- Easy die changing plus secure die alignments provided with the positive die lock buttons.
- Long life expectancy is provided with heavy duty reinforced back.
- Mates with all universal type Hot-stick tooling.
- Rapid assembly and disassembly is provided with the quick disconnect hydraulic fitting.
- Type Y35BH-4 head is covered with 3/16" molded rubber.
- 5-year limited warranty.

#### SPECIFICATIONS

	Y35BH	Y35BH-4
Operating pressure:	10,000 psi	10,000 psi
Jaw Opening:	.95"	.95"
Force developed:	12 tons	12 tons
Weight (less case):	8 lbs.	9 lbs.
Maximum width:	4-3/4"	6"
Maximum height:	9-1/4"	10-1/2"
Molded covering:	—	Yes

#### FOR USE ON

CONNECTOR TYPE	CONDUCTOR RANGE	
Tension Sleeves	Copper	#8 sol.-500 kcmil
	Aluminum	#6 sol.-636 kcmil
	ACSR	#4 -556.5 (26/7)
Taps	#14-556.5 ACSR (18/1)	
Aerial Cable Connectors	Copper	#6 str.-500 kcmil
	Aluminum	#4 str.-600 kcmil
Code Conductors	Copper	#8 str.-750 kcmil Term (400 kcmil splice)
	Aluminum	#6 str.-750 kcmil Term (400 kcmil splices)
	HYGROUNDTM Compression Grounding	
	Copper (cable/cable)	#6-500 kcmil
	Copper (cable/grd. rod)	#6-250 kcmil
	Ground Rods	1/2"-3/4"

#### Y35BH Variations:

**Y35BH** Head Only.

**Y35H** Includes the Y35BH HYPRESS™ head, PT29402-1 universal hot-stick adapter, and steel carrying case.

**Y35B** Includes the Y35BH HYPRESS™ head, PT91 steel reinforced hydraulic hose and an FP10 foot pump in a steel carrying case. Note: NOT for use on energized conductors.

**Y35BH-4** Permanent Molded Rubber Head. The Y35BH-4 is covered with 3/16" molded rubber for tool impact protection (not insulation).

#### FEATURES

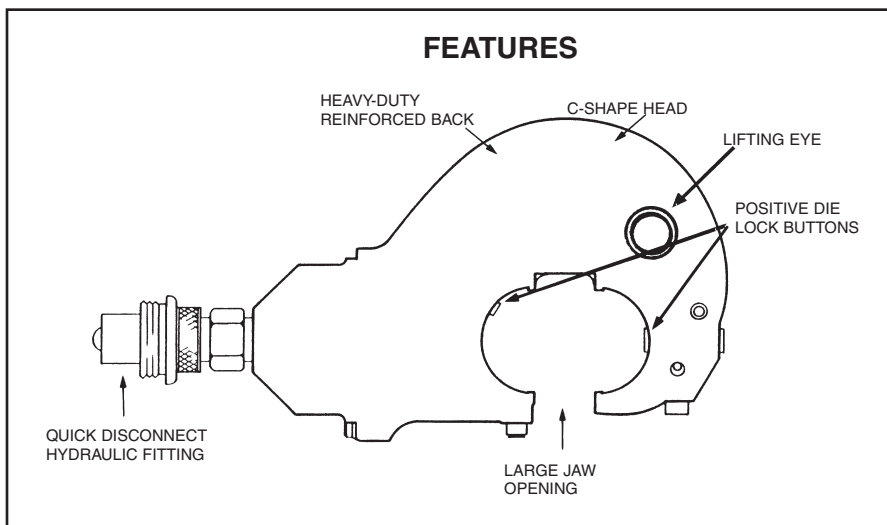

### TYPE Y39BH HYPRESS™ 10,000 PSI

#### REMOTE POWER OPERATED COMPRESSION TOOL

The Y39BH Remote Head is designed for remote power operation and incorporates the same small head as the Y39. Convenient die holder with recessed spring latch makes it easy to remove or lock into position. Dies are located and held in position with positive push button die locks. Dies sold separately. Five-year limited warranty.



#### BENEFITS

- Easy to work in small tight spaces with only a 3-1/8" wide compression head.
- Easy to locate and hold dies in position with the positive push button die locks plus die changing is accomplished easily without ball checks or set screws.
- Easy to remove or lock into position die holder with recessed spring latch plus leather strap to prevent loss.
- Compression terminal, tap and splice connectors are UL listed and CSA certified when installed with the Y39 tool and recommended die set.
- Very versatile tool that is able to work with 10,000 PSI pumps.
- 5-year limited warranty.

#### SPECIFICATIONS

Operating pressure: 10,000 psi  
 Force developed: 12 tons  
 Weight: 6-1/2 lbs.  
 Maximum head width: 3-1/8"  
 Minimum height: 9-1/8"

#### FOR USE ON

##### COPPER

#6 AWG-750 kcmil str.  
 Code Cable  
 N30-N650 Navy Cable  
 Flexible and Extra Flexible  
 Terminals-Uninsulated  
 YA, YA-L, YA-LB, YGH, YGHA  
 Splices and Tees-Uninsulated  
 YS, YS-L, YS-LB, YS-T, YSP-T, YST

##### COPPER-AN or AIR

#6 AWG-4/0 str. Code Cable  
 AN6-AN 4/0 Aircraft Cable  
 Flexible and Extra Flexible  
 Terminals-Uninsulated  
 YAV-L Box, YAV-L, YAV-Rs Box, YAV-RS  
 Splices and Tees-Uninsulated  
 YSV-L Box, YSV-L

##### COPPER-INSULATED TERMINALS

#8-AWG-2/0 str. Code Cable  
 AN8-AN 2/0 Aircraft Cable  
 Flexible and Extra Flexible  
 Terminals-Insulated  
 YAEV-L Box, YAEV-L, YAEV-RS Box,  
 YAEV-RS, YAEV-RH

##### COPPER - TAPS

#12 AWG Solid-250 kcmil  
 Taps-YC-C, YGHC-C, YGHP-C, YGHR-C,  
 YH, YCHC

##### ALUMINUM

#8 AWG-750 kcmil str.  
 Code Cable  
 Terminals-YA-A  
 Splices-YA-A, YS-AT, YRB

##### ALUMINUM

#6 str.-500 kcmil  
 Taps-YFD, YFN, YFO

#### FEATURES

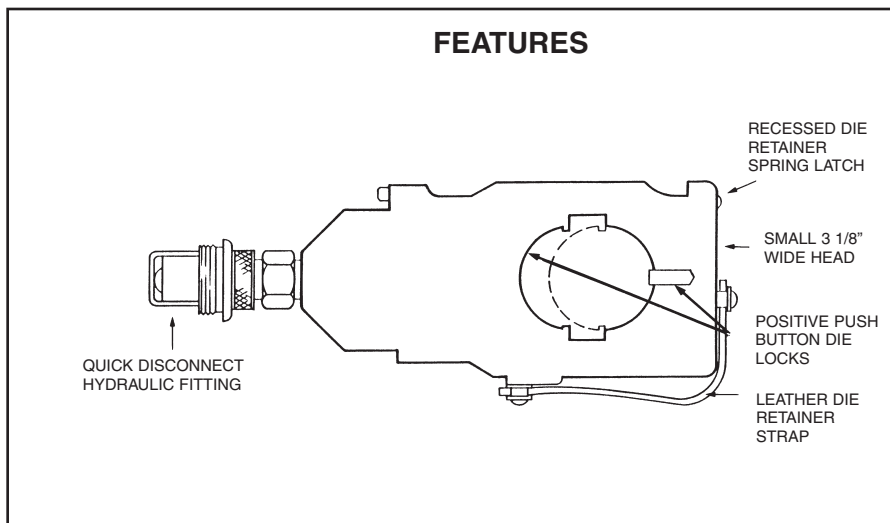

### TYPE Y34BH HYPRESS™

#### HYDRAULIC TOOL - REMOTE OPERATED 10,000 PSI

9 ton remote power operated hydraulic tool. The Y34BH HYPRESS™ tool is designed for remote hydraulic power operation. Its new 10,000 PSI operating pressure makes it easily adaptable to most remote power systems. Its small C-shaped head is light-weight, compact and with a relatively large jaw opening ideally suited for NETWORK UNDERGROUND systems. The tool comes standard with permanent molded head with 3/16" rubber and includes a separate molded rubber boot that covers the lower body and hydraulic coupler for tool impact protection. Together, with other BURNDY® hydraulic accessories, the Y34BH HYPRESS™ tool may be used on lines. The Y34BH-1 has a ten foot non-conductive 10,000 PSI hose attached at the factory. The Y34BH Series tool has a 5-year limited warranty.



#### BENEFITS

- Allows for easy placement and removal from continuous conductor lengths.
- Long life.
- Fast ram retraction.
- Molded rubber covering on head, body, and hose fittings.
- Standard operating pressure.
- Ease in handling.
- Greater reliability.
- Reduced tool life cycle cost.
- 5-year limited warranty.

#### SPECIFICATIONS

Operating pressure: 10,000 psi  
 Jaw opening: 1-1/2"  
 Max force generated: 9 Tons  
 Head and body rubberized  
 Accommodates "B" dies  
 Head length: 11-1/2"  
 Overall dimensions: 16-3/4" (incl. boot)  
 Total weight: Approx. 8 lbs.

#### FOR USE ON

- Copper #4-500 kcmil str.  
 Welding Cable-350 kcmil  
 N40 to N500 Navy Cable  
 Flexible and Extra Flexible  
 #4 to 4/0 Aircraft Cable  
 Hylugs™-Terminals-Uninsulated  
 Hylinks™-Splices and Tees-Uninsulated
- Hycrabs-Burndy Network Connector System.  
 Copper #4-500 kcmil str.  
 Aluminum-#6-300 kcmil

INSTALLATION	DIE	MAX. CONDUCTOR SIZE	
		Copper	Aluminum
B4CD	Y34PA	#6 STR.	#6 STR.
B1CD	Y34PA	#4 STR.	#4 STR.
B26D	Y34PA	#2 STR.	#2 STR.
B26D	Y34PR-5	#1 STR.	#1 STR.
B27D	Y34PR-5	1/0 STR.	1/0 STR.
B29D	Y34PR-5	2/0 STR.	2/0 STR.
B30D	Y34PR-5	3/0 STR.	3/0 STR.
B31D	Y34PR-5	4/0 STR.	4/0 STR.
B32D	Y34PR-5	250 kcmil	250 kcmil
No die req'd.	Y34PR-11	300 kcmil	300 kcmil

INSTALLATION	DIE	MAX. CONDUCTOR SIZE	
		Copper	Aluminum
B4CD	Y34PR	#4 STR.	#4 STR.
B2CD	Y34PR	#2 STR.	#2 STR.
B1CD	Y34PR	#1 STR.	#1 STR.
B25D	Y34PR	1/0 STR.	1/0 STR.
B26D	Y34PR	2/0 STR.	2/0 STR.
B27D	Y34PR	3/0 STR.	3/0 STR.
B28D	Y34PR	4/0 STR.	4/0 STR.
B29D	Y34PR	250 kcmil	250 kcmil
B30D	Y34PR	300 kcmil	300 kcmil
B31D	Y34PR	350 kcmil	350 kcmil
No die req'd.	Y34PR	500 kcmil	500 kcmil

#### FEATURES

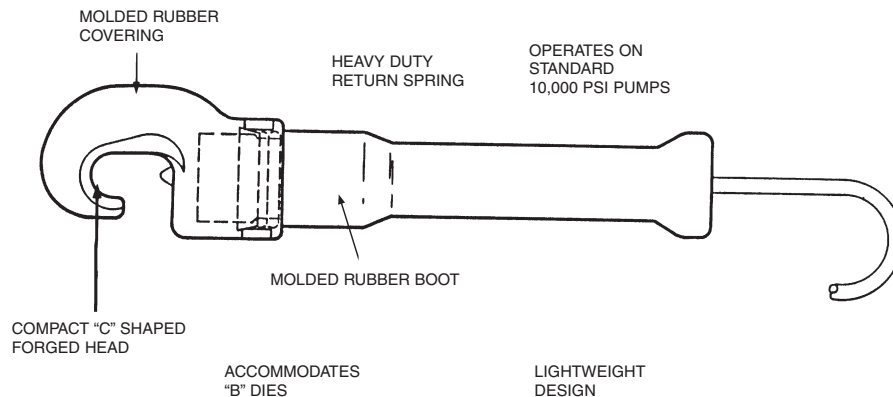

### TYPE Y29BH HYPRESS™ 6000 PSI

#### HYDRAULIC TOOL - REMOTE OPERATED

4.5 Ton remote power operated hydraulic tool. The Y29BH HYPRESS™ tool is designed for remote hydraulic power operation. Its small, 'C' shaped head is lightweight, designed for use in confined areas, where visibility and space is limited. Accommodates D-(series) nest dies and Y29-(series) indenter dies, for use with code or flex connector/conductor applications. Ideal for OEM applications. Dies sold separately. The Y29BH has a 5-year limited warranty.



#### BENEFITS

- Easy placement/removal on continuous conductor lengths.
- Lightweight, portable head design
- Companion tool of Y29NC pneumatic HYPRESS™.
- Installs a wide variety of lugs and splices
- Ideal for AN, flex and code conductor terminations.
- 5-year limited warranty.

#### SPECIFICATIONS

Operating Pressure: 6000 psi  
 Height: 3"  
 Length: 10.75"  
 (including coupler fitting)  
 Head Width: 1.15"  
 Jaw Opening: 1.2"  
 Weight: 5 lbs  
 Output Force: 4.5 tons (9000 lbs)  
 Crimp Type: Nest/Indentor

#### FOR USE ON

COPPER #8 - 4/0 AWG, code/flex

##### Nylon Insulated Lugs

(Connectors meet MIL-T-7928 requirements)

- YAEV-L, YAEV-H, YAEV-RS, YAEV-RH

##### Non-Insulated Lugs

(Connectors meet MIL-T-7928 requirements)

- YAV-L, YAV-R, YAV-RS

##### Non-Insulated Splices

(Type YSV-L connectors UL Listed, CSA Certified)

- YSM, YSV-L

(Consult 'Section B' of Catalog for detailed connector descriptions)

UNINSULATED CONNECTORS		MAXIMUM CONDUCTOR SIZE	INSULATED CONNECTORS	
NEST	IND.		NEST	IND.
DV8L-1	Y29PL	#8 AWG	DEV8L	Y29PLE-1
DV6L	Y29PL	#6 AWG	DEV6L	Y29PLE-1
DV4L	Y29PL	#4 AWG	DEV4L	Y29PLE-1
DV2L	Y29PL	#2 AWG	DEV2L	Y29PLE
DV1L	Y29PL	#1 AWG	DEV6L	Y29PLE
DV25L	Y29PL	1/0 AWG	DEV25L	Y29PLE
DV26L	Y29PL	2/0 AWG	DEV26L	Y29PLE

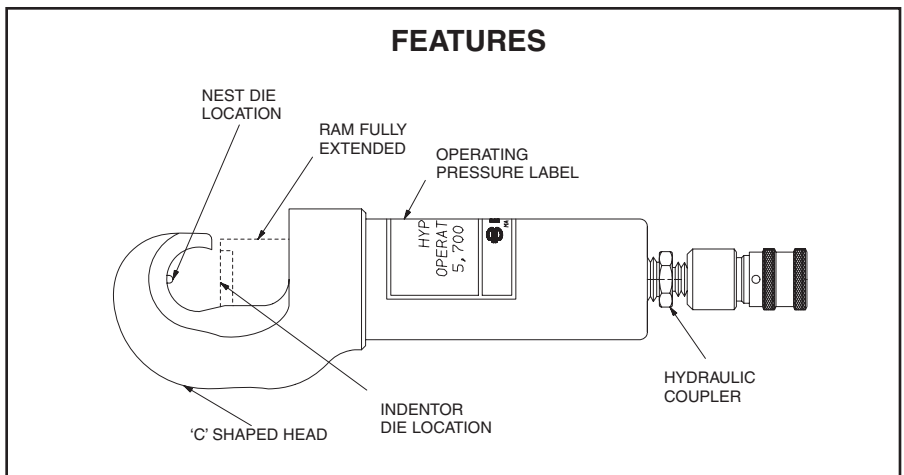

### TYPE Y750BH HYPRESS™ 10,000 PSI

#### 12 TON REMOTE POWER OPERATED HYDRAULIC TOOL

CONDUCTOR RANGE:  
#14-750 kcmil AL/CU  
#4-556.5 kcmil ACSR

12 ton remote power operated hydraulic tool. The Y750BH HYPRESS™ incorporates a wide mouth (1.65") C-shaped head for all compression applications. The hook style head provides for easy tapping, splicing, and terminating of overhead lines as well as the full range of HYGROUND™ compression grounding system connectors, NEC cable connections and N30-N650 Navy cable applications.

All standard BURNDY® Y35 series U dies fit the Y750BH HYPRESS™. Dies and accessories sold separately.

The Y750BH-2 has a permanently molded rubber head and includes a separate rubber molded boot that covers the lower body and hydraulic fitting for tool impact protection. Five-year limited warranty.



#### BENEFITS

- Covers a wide range of applications and provides easy tool removal from continuous conductors with its C-shaped head (1.65" opening).
- Easy die change out and retention within exposed positive die lock buttons.
- Uses all standard BURNDY® U-dies.
- Y750BH-2 provides molded rubber covering on head, body and hose fittings.
- Hot stick adapter sold separately.
- Infinitely rotatable head, so hydraulic couplers won't easily loosen.
- 5-year limited warranty.

#### SPECIFICATIONS

	Y750BH	Y750BH-2
Operating pressure:	10,000 psi	10,000 psi
Force developed:	12 tons	12 tons
Jaw opening:	1.65"	1.65"
Length:	12"	18.93" (includes boot)
Weight:	10.3 lbs.	11.8 lbs.
Head width:	4.43"	4.92"
Molded Covering:	—	Yes

#### FOR USE ON

- **Tension Sleeves**
  - Copper #8 sol-500 kcmil
  - Aluminum #6 sol.-587-2 kcmil
  - ACSR #4-556.5 kcmil
- **Taps**
  - Copper #14 solid 500 kcmil
  - Aluminum #6-500 kcmil
- **Aerial Cable**
  - Copper #6-500 kcmil
- **Terminals and Splices**
  - Aluminum #8-750 kcmil
  - Copper #8-750 kcmil
  - ACSR #4-556 kcmil
- **HYGROUND™ (Compression Ground)**
  - Copper #6-500 kcmil  
(cable/grd. rod)
  - Ground Rods 1/2 "-1" Diameter

#### ACCESSORIES:

Cat. No.:  
**PT23484**

Description:  
Hot stick adapter.

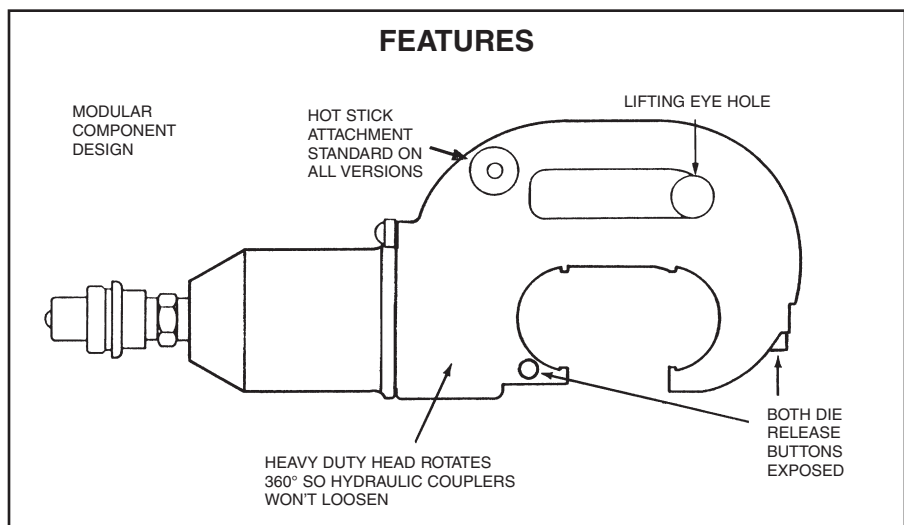



### TYPE KOMPRESSOR™ LPHY750

#### REMOTE OPERATED 12 TON LOW PRESSURE HYDRAULIC COMPRESSION TOOL

The BURNDY® LPHY750 KOMPRESSOR™ is a lightweight, compact, low pressure, hydraulic 12 ton crimping tool. The LPHY750 is double acting for hydraulic ram advance and retract. The KOMPRESSOR™ also has an industry exclusive spring back up for ram retraction in case of loss of hydraulic pressure. The LPHY750 comes equipped with an ergonomic handle designed for better balance, which helps lessen fatigue to the operator.

The LPHY750 KOMPRESSOR™ features the BURNDY® Y750 tool head with a 1.65" jaw opening capable of using all industry standard BURNDY® "U" dies. The LPHY750 also has an industry exclusive visual crimp indicator to assure the operator of a properly completed crimp. The LPHY750 also has an audible crimp indicator.

The LPHY750 is powered directly from open center or closed center hydraulic tool circuits present on most utility line trucks or can be operated from individual low-pressure hydraulic power units. The LPHY750 can be switched from open center to closed center operation with a simple external adjustment. The LPHY750 does not require any additional tooling such as boosters, intensifiers, or hand controls in the bucket. Five-year limited warranty.



#### BENEFITS

- Visual and audible crimp indicator assures properly completed crimps with 12 tons of force.
- Covers a wide range of applications with its 1.65" jaw opening.
- 350° head rotation for versatile tool head positioning allowing the user to get into tight areas easier.
- Uses all standard BURNDY® "U" dies.
- Operates on open center or closed center hydraulic systems.
- Ergonomic handle design for better balance and helps lessen fatigue.
- Double acting tool for hydraulic ram advance and retraction.
- Spring back up for ram retraction if hydraulic system shuts down.
- 5-year limited warranty.

#### SPECIFICATIONS

##### LPHY750

Flow Rate:	3 - 9 GPM (11 - 34 LPM)
Operating Pressure:	1,500 - 2,500 psi (103 - 172 BAR)
Force Developed:	12 Tons
Weight:	21 lbs (9.5 kg)
Overall Length:	20.65 in (524 mm)
Width:	15 in (381 mm)
Jaw Opening:	1.65 in (42 mm)
Max. Back Pressure:	250 psi (17 BAR)
Crimp Time:	Approximately 2 seconds

#### FOR USE ON

##### • Tension Sleeves

Copper	#8 sol - 500 kcmil
Aluminum	#8 sol - 587.2 kcmil
ACSR	#4 - 556.5 kcmil

##### • Taps

Copper	#14 sol - 500 kcmil
Aluminum	#8 sol - 500 kcmil

##### • Aerial Cable

Copper	#6 - 500 kcmil
--------	----------------

##### • Terminals and Splices

Copper	#8 - 750 kcmil
Aluminum	#8 - 750 kcmil
ACSR	#4 - 556.5 kcmil

##### • HYGROUND™

Copper	#8 - 500 kcmil
Ground Rods	1/2" - 1" diameter

#### ACCESSORIES

##### Hoses:

Cat No. **LPHTHOSNCR66668OP**

Direct connect 8' non-conductive hose set

Cat No. **LPHTHOSNCR666610OP**

Direct connect 10' non-conductive hose set

\*Cat No. **LPHTHOSNCR66668**

8' non-conductive hose set

\*Cat No. **LPHTHOSNCR666610**

10' non-conductive hose set

##### Hydraulic Fittings:

Cat No. **LPHTHTMANOSE66**

Male coupler 3/8" HTMA

Cat No. **LPHTHTMABODY66**

Female coupler 3/8" HTMA

Cat No. **LPHTADPSMFOP66**

Swivel Adapter

\*These hoses are used with the LPHTADPSMFOP66 swivel adapter.

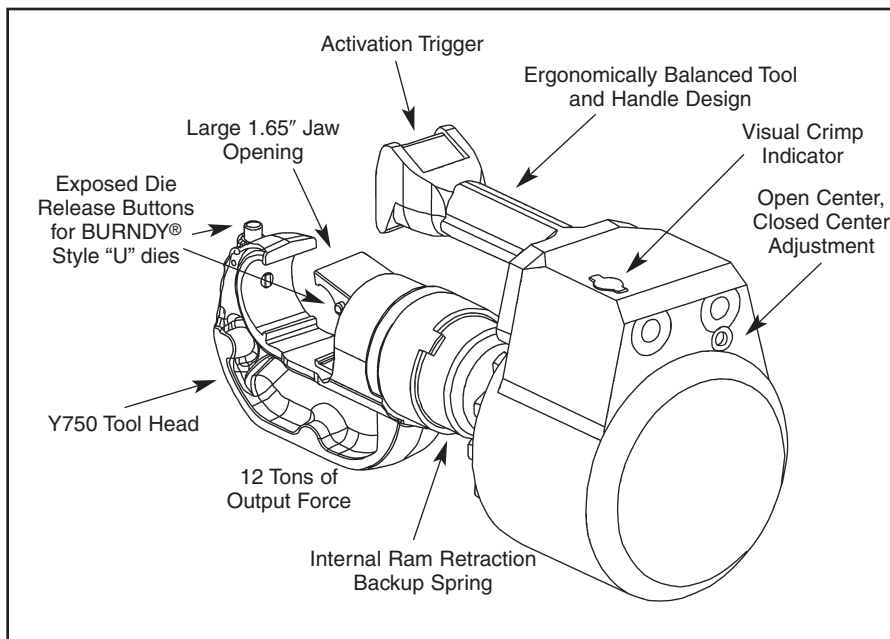

### TYPE KOMPRESSOR™ LPHY46

#### REMOTE OPERATED 15 TON LOW PRESSURE HYDRAULIC COMPRESSION TOOL

The BURNDY® LPHY46 KOMPRESSOR™ is a compact, low pressure, hydraulic 15 ton crimping tool. The LPHY46 is double acting for hydraulic ram advance and retract. The KOMPRESSOR™ also has an industry exclusive spring back up for ram retraction in case of loss of hydraulic pressure. The LPHY46 comes equipped with an ergonomic handle designed for better balance, which helps lessen fatigue to the operator.

The LPHY46 KOMPRESSOR™ features the BURNDY® Y46 tool head with a 2" jaw opening capable of using all industry standard BURNDY® "P" dies, and "U" dies, with PUADP-1 adapter. The LPHY46 has a visual and audible crimp indicator that assures properly completed crimps with 15 tons of force.

The LPHY46 is powered directly from open center or closed center hydraulic tool circuits present on most utility line trucks or can be operated from individual low-pressure hydraulic power units. The LPHY46 can be switched from open center to closed center operation with a simple external adjustment. The LPHY46 does not require any additional tooling such as boosters, intensifiers, or hand controls in the bucket. Five-year limited warranty.



#### BENEFITS

- Visual and audible crimp indicator assures properly completed crimps with 15 tons of force.
- Covers a wide range of applications with its 2" jaw opening.
- 350° head rotation for versatile tool head positioning allowing the user to get into tight areas easier.
- Uses all standard BURNDY® "P" dies, and "U" dies with PUADP-1 adapter.
- Operates on open center or closed center hydraulic systems.
- Ergonomic handle design for better balance and helps lessen fatigue.
- Double acting tool for hydraulic ram advance and retraction.
- Spring back up for ram retraction if hydraulic system shuts down.
- 5-year limited warranty.

#### SPECIFICATIONS

##### LPHY46

Flow Rate:	3-9 GPM (11-34 LPM)
Operating Pressure:	1,550-2,500 psi (107-172 BAR)
Force Developed:	15 Tons
Weight:	28.5 lbs (13 kg)
Overall Length:	18 in (465 mm)
Width:	6 in (153 mm)
Max. Back Pressure:	250 psi (17 BAR)
Crimp Time:	Approximately 2 seconds

#### FOR USE ON

CONNECTOR TYPE	CONDUCTOR RANGE
Copper #8-AWG str. - 1500 kcmil Code Cable Navy Cables Flexible and Extra Flexible 1/2"-1" Ground Rods	Terminals-grounding to 500 kcmil YGA, YGHA, YGF Terminals-Uninsulated #8 to 1500 kcmil YA, YA-2N, YA-L YA-LB, YA-TC, YA-2LN, YAB-4N YAV-L Box, YAV-L, YAV-RS Box, YAV-RS, YA-TC-FX Terminals-Insulated #8 to 2/0 YAEV-L Box, YAEV-L, YAEV-H, YAEV-RS, YAEV-RH Splices #8 to 1500 kcmil YS, YS-T, YS-L, YS-LB, YST, YSP-T, YGS, YGHS Taps YH, YCHC #14 to 1000 kcmil YC-C to 4/0 AWG Taps-Grounding to 500 kcmil YGHC-C, YGHP-C, YGHR-C
Aluminum #8 AWG- 1250 kcmil Code Cables	Terminals YA-A, AYP, AYPO Splices YS-A, YS-AT, YRB Taps YFD, YFN, YFO, YFR
ACSR	See Burndy Overhead Transmission and Distribution Catalog Module

#### ACCESSORIES

Cat No. **PUADP-1**

"U" - Die adapter

Cat No. **P15K**

Cutter die (max. 1.2" dia.)

##### Hoses:

Cat No. **LPHTHOSNCR66668OP**

Direct connect 8' non-conductive hose set

Cat No. **LPHTHOSNCR666610OP**

Direct connect 10' non-conductive hose set

\*Cat No. **LPHTHOSNCR66668**

8' non-conductive hose set

\*Cat No. **LPHTHOSNCR666610**

10' non-conductive hose set

##### Hydraulic Fittings:

Cat No. **LPHTHTMANOSE66**

Male coupler 3/8" HTMA

Cat No. **LPHTHTMABODY66**

Female coupler 3/8" HTMA

Cat No. **LPHTADPSMFOP66**

Swivel Adapter

\*These hoses are used with the LPHTADPSMFOP66 swivel adapter.

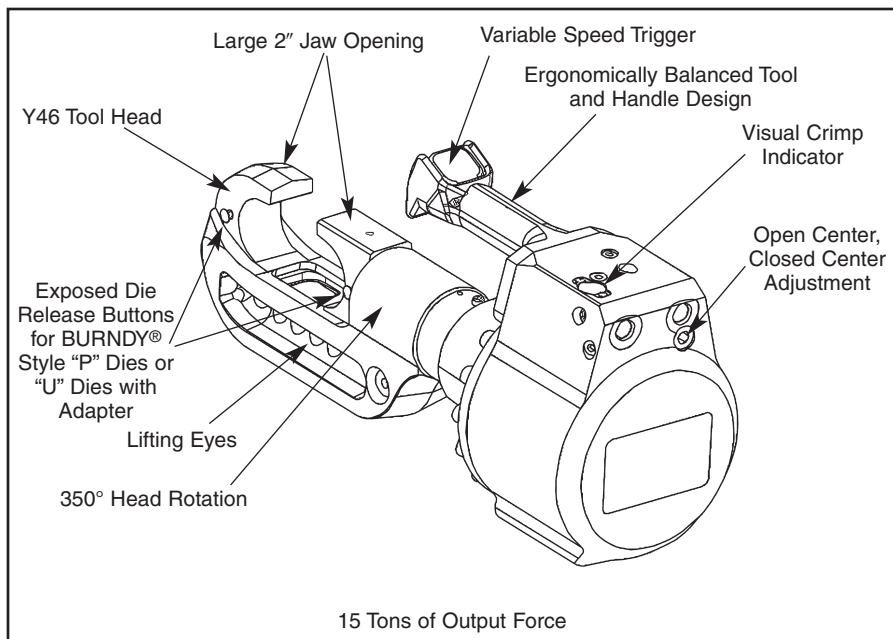

15 Tons of Output Force

### TYPE Y644MBH DIELESS HYPRESS™ 10,000 PSI

#### HYDRAULIC TOOL - REMOTE OPERATED

The "1" Crimp-Range Taking 11-Ton Force - Hydraulic Remote Tool #6-1000 kcmil Copper HYLUG™ Terminals and HYLINK™ Splices #6-1000 kcmil Aluminum HYLUG™ Terminal and HYLINK™ Splices

The "1" Crimp Type Y644MBH Dieless HYPRESS™ Remote Tool, crimps 195 different copper and aluminum HYLUG™ terminals and HYLINK™ splices, which cover the breadth of 38 code conductor sizes and 15 Navy cable sizes.

Only one (1) crimp is required for each wire termination for both long and standard length barrels on BURNDY® HYLUG™ and HYLINK™ connectors throughout the entire conductor range. The Y644MBH dieless remote head tool operates on 10,000 psi hydraulic pressure and develops an output force of 11 tons, the same as the self-contained Y644M Dieless HYPRESS™. Installation of BURNDY® YFO and YFD series H-CRIMPIT™ connectors can be accomplished by using the accessory adapters listed below, purchased separately. Five-year limited warranty.

The following size Hydent™ lugs and two way splices, when crimped with the Y644MBH Dieless Hypress™ Tool, produce the following range taking capabilities.

ALUMINUM CONNECTORS		COPPER CONNECTORS	
Standard Wire Size	Expanded Wire Range	Standard Wire Size	Expanded Wire Range
#6 AWG	#6 AWG	#6 AWG	#6 AWG
#5 AWG	#5-#6 AWG	#5 AWG	#5-#6 AWG
#4 AWG	#4-#6 AWG	#4 AWG	#4-#6 AWG
#3 AWG	#3-#6 AWG	#3 AWG	#3-#6 AWG
#2 AWG	#2-#6 AWG	#2 AWG	#2-#6 AWG
#1 AWG	#1-#2 AWG	#1 AWG	#1-#6 AWG
1/0 AWG	1/0-#1 AWG	1/0 AWG	1/0-#6 AWG
2/0 AWG	2/0-#1 AWG	2/0 AWG	2/0-#4 AWG
3/0 AWG	3/0-#1 AWG	3/0 AWG	3/0-#2 AWG
4/0 AWG	4/0-#1 AWG	4/0 AWG	4/0-#1 AWG
250 kcmil	250-1/0 AWG	250 kcmil	250-1/0
300 kcmil	300-2/0 AWG	300 kcmil	300-2/0
350 kcmil	350-3/0 AWG	350 kcmil	350-3/0
400 kcmil	400-4/0 AWG	400 kcmil	400-4/0
500 kcmil	500-4/0 AWG	500 kcmil	500-4/0
600 kcmil	600-250 kcmil	600 kcmil	600-250
750 kcmil	750-500 kcmil	750 kcmil	750-500
1000 kcmil	1000-750 kcmil	800 kcmil	800-500
		1000 kcmil	1000-750



#### BENEFITS

- Dieless system, eliminates the need to purchase and maintain dies.
- Easy tool positioning with its infinitely rotatable head.
- Easy inspection and positive identification is provided with the BURNDY® logo.
- H-CRIMPIT™ dies to crimp YFO and YFD type H-CRIMPIT™ taps offered as accessory option.
- Five-year limited warranty.

#### SPECIFICATIONS

Force Developed: 11 Tons  
 Operating Pressure: 10,000 psi  
 Head Width: 3.93"  
 Overall Length: 12"  
 Weight (less case): 9-1/2 lbs.

#### FOR USE ON

AWG/KCMIL WIRE SIZE RANGE	CONNECTOR TYPE
Copper #6-1000 kcmil	Terminals YA-L, YA-2LN, YA, YA-2N, YA-L-2TC, YAB-4N, YA-L-TC, YA-2L, YA-4N Splices YS-L, YS-T, YS
Aluminum #6-1000 kcmil	Terminals YA-A, YA-A-TN Splices YS-A
Aluminum #6-750 kcmil	HYPLUG™ AYP, AYPO
Aluminum #6-250 kcmil	Taps H-CRIMPIT™ YFO, YFD

#### ACCESSORIES

- Cat. No. **PT30541**  
 • Die for YFO series H-CRIMPIT™
- Cat. No. **PT30540**  
 • Die for YFD series H-CRIMPIT™

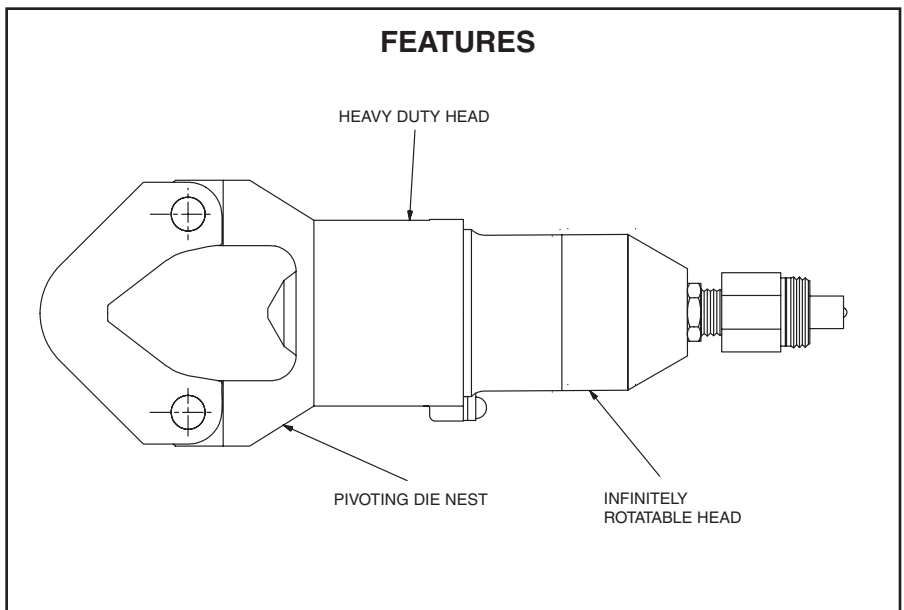

### TYPE 4-POINT™ Y81KFTMBH

#### DIELESS HYPRESS™

10,000 PSI

DIELESS HYDRAULIC TOOL – REMOTE OPERATED

#8 - 1000 KCMIL COPPER HYLUG™ TERMINALS and HYLINK™ SPLICES

#8 - 750 KCMIL ALUMINUM HYLUG™ TERMINALS and HYLINK™ SPLICES

The Y81KFTMBH 4-POINT™ dieless HYPRESS™ is a remote powered 6 ton hydraulic crimping tool for use on a wide variety of terminal and splice compression applications. The Y81KFTMBH incorporates a dieless latch style head that provides easy tool removal from continuous conductor runs and eliminates the need to purchase and maintain dies. The Y81KFTMBH dieless remote head tool operates on 10,000 psi hydraulic pressure and develops an output force of 6 tons, the same as the self contained Y81KFTMBH. The result is easy termination and splicing using BURNDY® HYLUG™ and HYLINK™ terminals and splices.

The Y81KFTMBH is supplied with a canvas bag and quick connect fittings and comes complete with a 5-year limited warranty.

Y81KFTMBH dieless HYPRESS™ Range Taking Capabilities: The Y81KFTMBH provides range taking capabilities that is UL and CSA listed for Copper (Code, Compact and Flex) and Aluminum (Code and Compact) conductors when used in conjunction with BURNDY® HYLUG™ terminals and HYLINK™ splices. *See chart for connector, conductor and range taking combinations.*

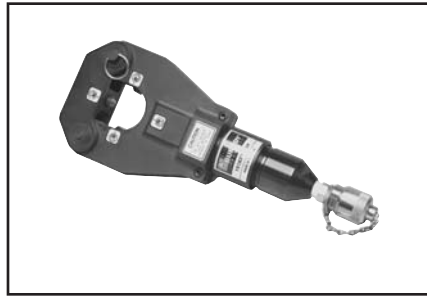

#### Features and Benefits

- Dieless installation system.
  - ◊ Eliminates the need to purchase and maintain dies.
- UL Listed and CSA Certified with Range Taking Capabilities
  - ◊ Provides the installer with UL Listed and CSA Certified crimps with Range Taking Capabilities when used in conjunction with BURNDY® HYLUG™ Terminals and HYLINK™ Splices.
- Flip top head design.
  - ◊ For easy loading and removal of installed terminals and splices, saving time.
- Incorporates Parker type quick connect couplers.
  - ◊ Eases installation time.
- Audible pressure "pop-off" valve and die embossment providing 360° inspectability.
  - ◊ Assures proper crimps with both audible and visual indicators for the installer.
- 5-year limited warranty on tool.
  - ◊ Customer satisfaction and support.

#### SPECIFICATIONS

<b>Output Force:</b>	6 tons (12,000 lbs.) (5.4 Metric Tons)
<b>Weight:</b>	8.5 lbs (3.86 kg)
<b>Overall Length:</b>	13.9 in (354 mm)
<b>Head Width:</b>	5.4 in (138 mm)
<b>Operating Pressure:</b>	10,000 psi (68.9 MPa)

#### FOR USE ON

- Copper, Aluminum, Compressed, Compact, Stranded, Solid and Flex Conductors.
- Installs Splices, Taps and Terminations:
  - #8 - 1000 kcmil Copper (YA, YA-L, YS, YS-L, YS-T, Y-R )
  - #8 - 777.7 (750 Nominal Flex Wire Size) kcmil Flex (YA-FX, YAV, YA-L-FX, YS, YSV-FXB)
  - #8 - 750 kcmil Aluminum (YA-A, YS-A)
  - #8 - 750 kcmil Aluminium Pin Adapters (AYP, AYPO)

N-46

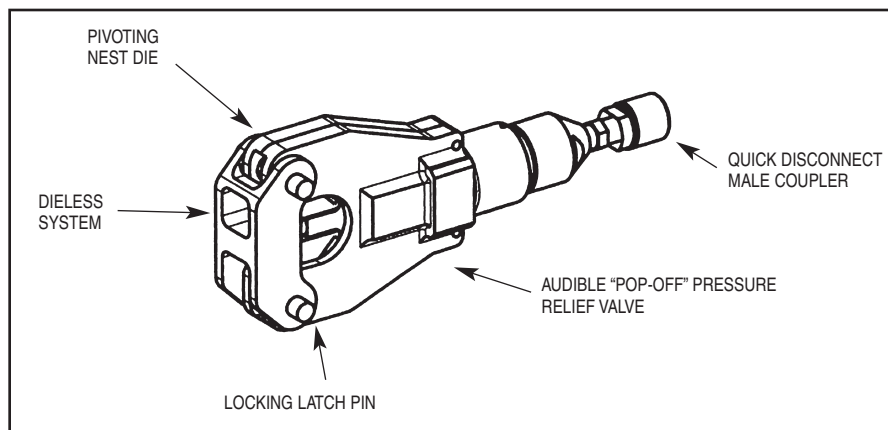

### TYPE Y45 HYPRESS™ 10,000 PSI

### 15 TON REMOTE POWER OPERATED HYDRAULIC TOOLS

The Y45 Series is designed for remote hydraulic operation. A C-shaped head design provides easy installation of tap and splice connectors. The hook style head with extensive ram travel operates easily on large distribution and transmission conductors. Together with accessories, the Y45 Series tooling may be used on overhead lines. The small light-weight head design is very adaptable for work in underground trenches and manholes.

Cat. No. **PT6515** is required to use "U-" type dies in all Y45 variations. Order Head, Hose, Pump, Dies, and accessories separately. 5-year limited warranty.



PT6545

### BENEFITS

- Easy connector installation and tool removal from line conductors with the open C-shaped head.
- Easily lifted into working position using lifting eye.
- Easy die changing plus secure die alignment is provided with the positive die lock buttons.
- Long life expectancy is provided with fully protected ram and die buttons.
- Rapid assembly and disassembly is provided with the quick disconnect hydraulic coupler.
- Rugged design provides long life expectancy.
- 5-year limited warranty.

### SPECIFICATIONS

	<b>Y45</b>
Operating pressure:	10,000 psi
Force developed:	15 Tons
Weight (less case):	15-3/4 lbs.
Maximum Width:	7-1/4"
Maximum Height:	14-1/4"

### FOR USE ON

AWG/KCMIL WIRE SIZE RANGE	CONNECTOR TYPE	
Tension Sleeves	Copper	#8 sol.-500 kcmil
	Aluminum	#6 sol.-954 kcmil
	ACSR	#4 -795 (26/7)
Taps	Aluminum	#14-954 (18/1) ACSR
	ACSR	#6-795 (54/7)
Aerial Cable Connectors	Copper	#6 str.-1500 kcmil
	Aluminum	#4 str.-1000 kcmil
HYGROUND™		
Compression Grounding	Copper	#6-500 kcmil 1/2" - 1" ground rods
Code Cable Terminals and Splices	Copper	#8-1500 kcmil
	Aluminum	#8-1000 kcmil
Taps	Copper	#14-1000 kcmil
	Aluminum	#14-900 kcmil

### ACCESSORIES:

Cat. No. **PT6515**

Description:

Adapter for use with "U-"die sets.

Cat. No. **PT6547-2**

Description:

Universal Hot-stick adapter for Y45 HYPRESS™ tools.

Cat. No. **PT6581**

Description:

Fiberglass handle adapter for Y45 (10,000 PSI)

Cat. No. **PT6545**

Description:

Die carrying case for "S-" and "P" type dies. Holds eight (8) die sets. (Dies sold separately.)

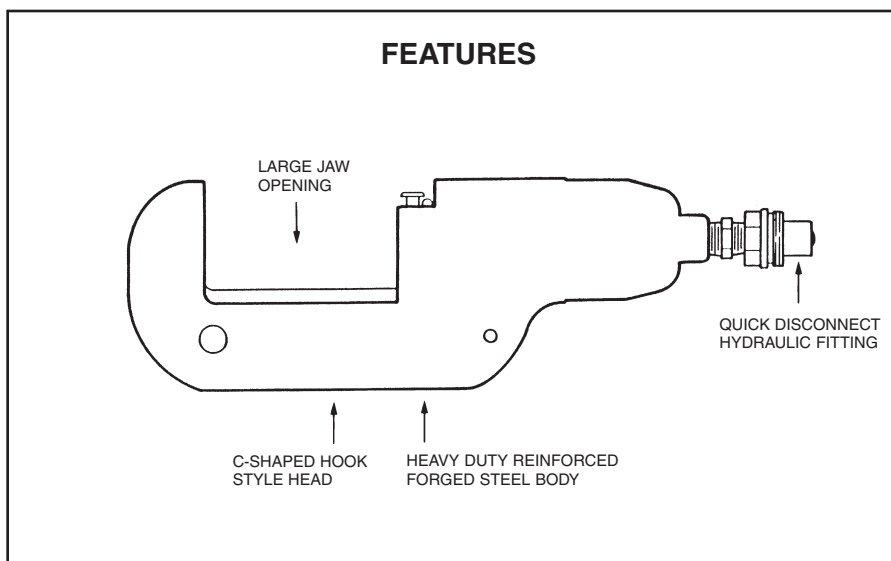



### TYPE Y46 AND Y46C HYPRESS™ 10,000 PSI

#### 15 TON FORCE - REMOTE OPERATED HYDRAULIC TOOL

The Y46 standard tool and Y46C rubber covered tools are lightweight, compact and versatile with installation dies for both circumferential and nest-indentor types. Accessories include "U-" die adapter, a cable cutting die for 1.2" diameter non-steel conductors, plus a lifting eye and universal hot-stick adapter for overhead line construction. 5-year limited warranty.



#### BENEFITS

- Compact "C" shaped head allows easy placement and removal from continuous conductor lengths.
- Versatile and economical-HYPRESS™ tools work on all commonly used copper and aluminum products.
- Dies and adapters lock into or remove from tool head easily with the positive push button die locks.
- Safety, strength and high quality is provided with strong forged steel and precision machined components.
- Excellent for HYGROUNDTM compression grounding applications through 1" ground rods and up to 500 kcmil taps, terminals and splices.
- Compression terminal, splice and tap connectors are UL listed and CSA certified when installed with the Y46 and Y46C HYPRESS™ and recommended die set.
- Y46C has a permanently molded head of 3/16" rubber and includes a separate molded rubber boot to cover the lower HYPRESS™ body and hydraulic coupler for impact protection.

#### SPECIFICATIONS

	Y46	Y46C
Force developed:	15 Tons	15 Tons
Operating pressure:	10,000 psi	10,000 psi
Jaw opening:	2"	2"
Maximum width:	4-1/2"	4-3/4"
Overall length:	15"	21-3/4" (incl. boot)
Weight (less case):	16 lbs.	17-1/2 lbs.
Molded Covering:	No	Yes

#### FOR USE ON

CONNECTOR TYPE	CONDUCTOR RANGE
Copper	Terminals-grounding to 500 kcmil
#8 AWG str.-	YGA, YGHA, YGF
1500 kcmil	Terminals-Uninsulated #8 to
Code Cable	1500 kcmil YA, YA-2N, YA-L,
Navy Cables	YA-LB, YA-TC, YA-2LN, YAB-4N,
Flexible and	
Extra Flexible	YAV-L Box, YAV-L, YAV-RS Box,
1/2"-1" Ground Rods	YAV-RS, YA-TC-FX
	Terminals-Insulated #8 to 2/0
	YAEV-L Box, YAEV-L, YAEV-H,
	YAEV-RS, YAEV-RH
	Splices #8 to 1500 kcmil
	YS, YS-T, YS-L, YS-LB, YST,
	YSP-T, YGS, YGHS
	Taps
	YH, YCHC #14 to 1000 kcmil
	YC-C to 4/0 AWG
	Taps-Grounding to 500 kcmil
	YGHC-C, YGHP-C, YGHR-C
Aluminum	Terminals
#8 AWG-	YA-A, AYP, AYO
1250 kcmil	Splices
Code Cables	YS-A, YS-AT, YRB
	Taps
	YFD, YFN, YFO, YFR
ACSR	See Burndy Overhead Transmission and Distribution Catalog Module

#### FEATURES

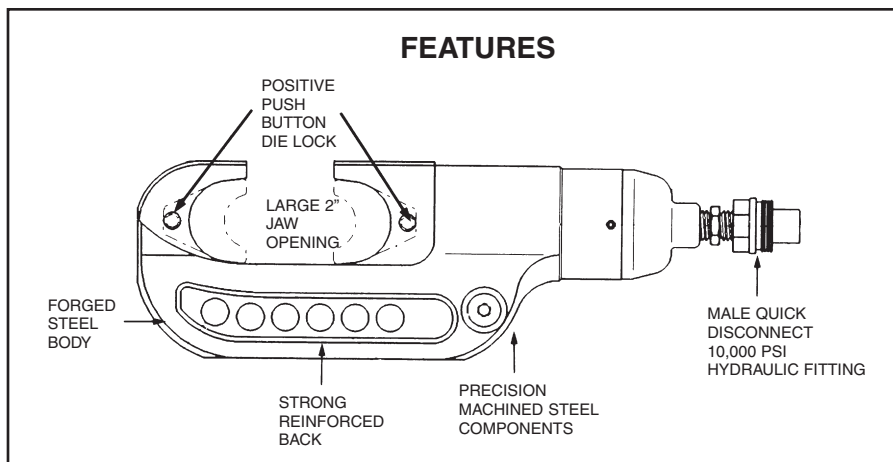

#### ACCESSORIES:

Cat. No.	Description
P15K	Cutter die max. 1.2" dia.
PUADP-1	"U"-die adapter
PT10121	Lifting eye
PT10128	Universal hotstick adapter-Y46
PT10131	Universal hotstick adapter-Y46C
Y46-2	Same as Y46 with Female coupler



### TYPE Y48BH HYPRESS™ 8,800 PSI

#### 40 TON REMOTE POWER OPERATED HYDRAULIC TOOL

The Y48 series is designed for remote hydraulic power operation. It features a "U" type head which makes it convenient to remove from installed splices. The head is insulated from the assembled hose and pump. The Y48 is designed for easy die insertion without set screws. Operates at 8,800 PSI and provides 40 tons of force. Uses "C" dies. Dies sold separately. Five-year limited warranty.

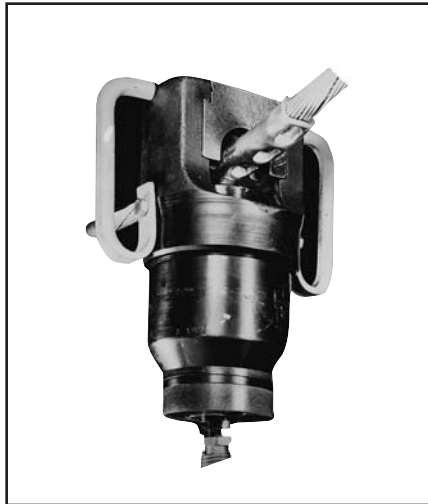

#### BENEFITS

- Easy die changing is provided with ball checks.
- Rugged design provides long life expectancy
- Head is insulated from assembled hose and pump.
- Provides 40 tons of force.
- Handles on both side of head makes it easy to carry and position.
- 5-year limited warranty.

#### SPECIFICATIONS

Operating pressure: 8800 psi  
 Forced developed: 40 Tons  
 Weight: 26 lbs.  
 Maximum width: 8-1/2"  
 Height: 10"

#### FOR USE ON

##### Copper

4/0-2,000 mcm

Terminals

YA, YA-2N, YAB-4N, YA-L, YA-2LN, YA-LB

Splices

YS, YST, YS-L, YS-T, YSP-T

##### Aluminum

3/0-1,500 mcm

Terminals

YA-A

Splices

YS-A, YS-AT

Full Tension Splices

COPPER-4/0-1,000 mcm-YDS

ACSR-3/0 (6-1)-795 (54-7)-YDS-R

ALUMINUM-4/0-795 mcm-YDS-AT

Cat. No.

**Y48BH** Head Only

Cat. No.

**Y48B** Includes head, carry case,

**PT76** 8' long steel braided hose and

**FP8** foot pump.

#### FEATURES

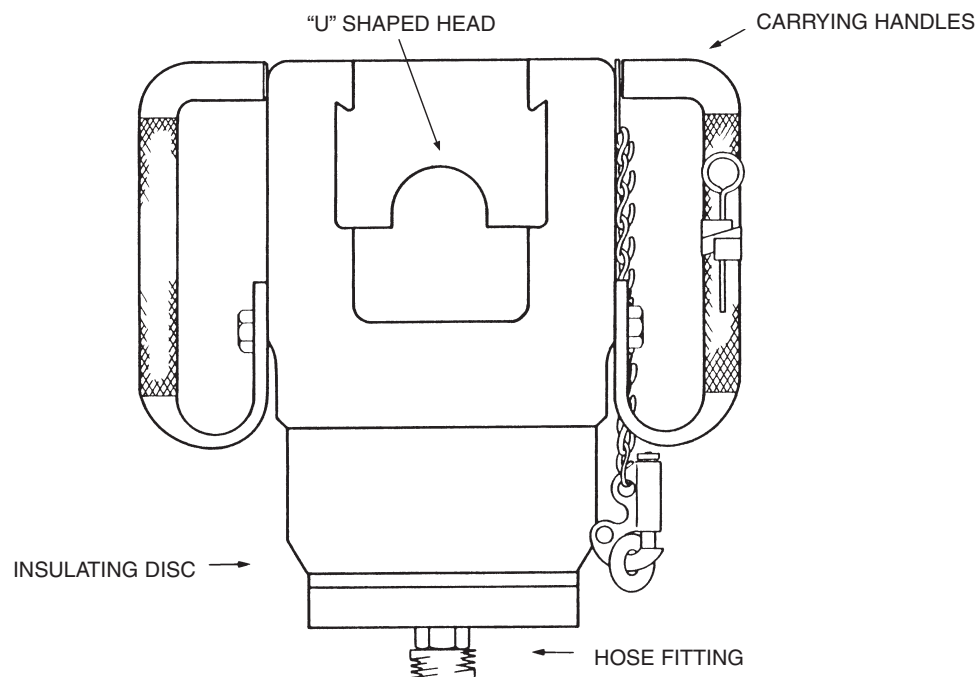

### TYPE Y60BHU AND Y60BHU-D HYPRESS™

#### 60 TON REMOTE POWER OPERATED HYDRAULIC TOOLS

#### SINGLE AND DOUBLE ACTING HYDRAULIC TOOL DESIGNS

The Y60BHU HYPRESS™, single acting, and Y60BHU-D HYPRESS™, double acting, are both designed to provide fast, easy operation plus a durable and substantially longer design life expectancy. Both Y60BHU and Y60BHU-D HYPRESS tools accommodate the same "L" dies. The "L" dies are designed for copper and aluminum code cables and aerial conductor sizes through 2500 kcmil and will accommodate ACSR through 2156 (84/19) str. Five-year limited warranty.

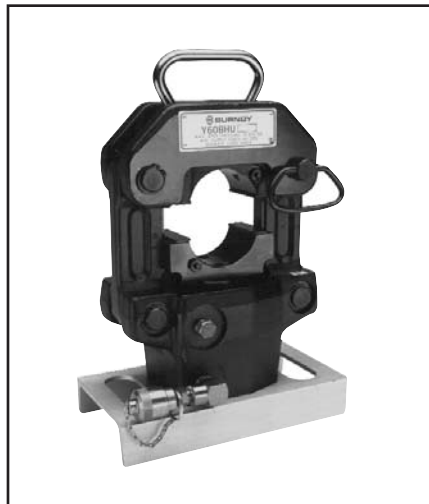

#### BENEFITS

- Easy to carry with heavy duty handle.
- Easy to remove splices with nest that pivots open.
- Safety and security is provided with captive locking pin for nest die.
- Long life expectancy (50,000 cycles) with heavy duty steel frame.
- Fast easy die changing and secure die positioning with positive die release locking pins.
- Faster retraction with double acting hydraulic system (Y60BHUD).
- Protected male coupler with captive cap.
- Stability is provided with sturdy steel base.
- Easy, less costly repairs with fewer parts that are easily accessible. Ex: Bottom die holder.
- 5-year limited warranty.

#### SPECIFICATIONS

Force developed: 60 tons  
 Operating pressure: 10,000 psi  
 Hydraulic oil: BURNDY® ALFLUID  
 Life expectancy: 50,000 cycles min.  
 Height: 16.62"  
 Weight (less case): 70 lbs.  
 Shipping weight: 97 lbs.

#### FOR USE ON

##### COPPER

300 kcmil-2000 kcmil  
 Str. Code Cable  
 Terminals  
 YA, YA-2N, YAB-4N, YA-L, YA-2LN, YA-LB  
 Splices  
 YS, YST, YS-L, YS-T, YSP-T

##### ALUMINUM

250 kcmil-2000 kcmil  
 Str. Code Cable  
 Terminals  
 YA-A  
 Splices  
 YS-A, YS-AT

##### TRANSMISSION AND DISTRIBUTION CONNECTORS

Tension Sleeves:  
 Copper: 1/0 str.-1000 kcmil  
 Aluminum: 1/0 str.-2300 kcmil  
 ACSR: 1/0-2156 (84/19 str.)  
 Aerial:  
 Copper: 4/0 str.-2500 kcmil  
 Aluminum: 3/0 str.-2500 kcmil  
 YTS, YTN, YNS, YNA, YNT, YNTA, YNU,  
 YDS, YDN, YCS, YCA, YCU

#### FEATURES

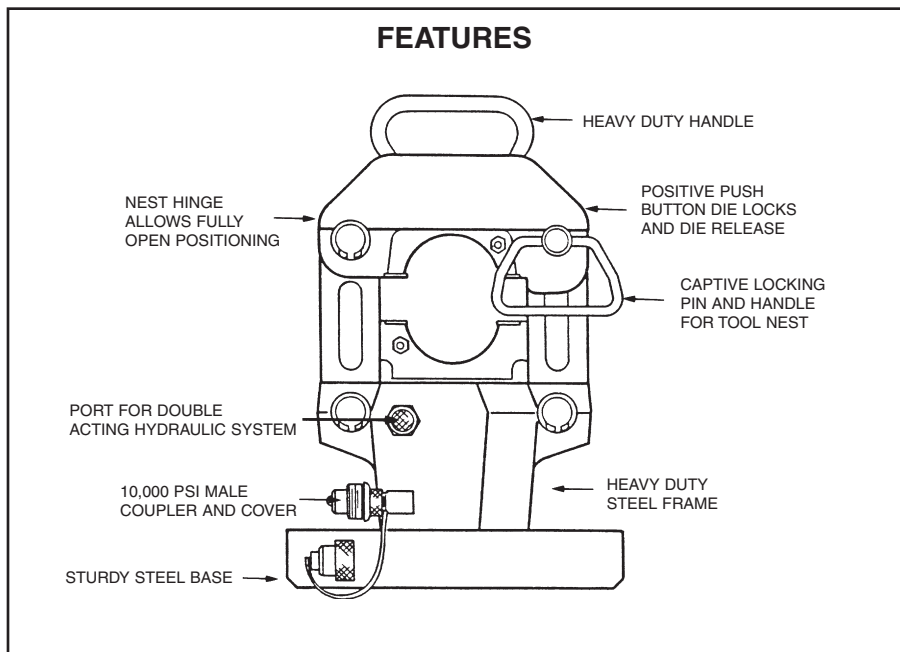

### TYPE RHCC129ACSR

#### 10,000 PSI Remote Cable Cutter

#### REMOTE POWER OPERATED HYDRAULIC CABLE CUTTER

The BURNDY® RHCC129ACSR remote hydraulic cable cutter incorporates a specialized latch style cutting head that allows interference-free closure for mid-span cuts. The RHCC129ACSR with its precision cutting blades is capable of cutting up to 1.29" diameter bare or insulated copper and aluminum cable, 1113 ACSR, 5/8" ground rod, 1/2" rebar, 5/8" diameter soft steel bolts, 1/2" standard guy strand, and up to 3/8" EHS guy strand.

The RHCC129ACSR is provided with a 5-year limited warranty (excluding blades).



#### Features and Benefits

- Specialized latch head design.
  - ◇ Interference free closure for mid-span cuts.
- Precision cutting blades.
  - ◇ For clean cuts on Cu/Al, ACSR, ground rods, rebar, guy strand, and soft steel bolts.
- High strength steel cylinder.
  - ◇ For durability and long life.
- Lightweight ergonomic design allows one hand operation.
  - ◇ User has one hand free to manipulate material to be cut.
- Durable canvas carrying bag.
  - ◇ Provides tool protection and stores all accessories.
- 5-year limited warranty on tool (excluding blades).
  - ◇ Customer satisfaction and support.

#### SPECIFICATIONS

Operating Pressure: 10,000 psi (700 bar)  
 Tool Weight: 5.85 lbs. (2.65 kg)  
 Length: 11.25" (286 mm)  
 Width: 3.7" (94 mm)

#### FOR USE ON

- Copper Cable: up to 1.29"
- Aluminum Cable: up to 1.29"
- ACSR: up to 1113 ACSR
- Ground Rod: up to 5/8"
- Rebar: up to 1/2"
- Soft Steel Bolts: up to 5/8"
- Standard Guy Strand: up to 1/2"
- EHS Guy Strand: up to 3/8"

#### ACCESSORIES

**Canvas Bag:** Cat# PT10043890

**Replacement Blades:** Cat# PT10037388 (Moving Blade)  
 Cat# PT10037384 (Fixed Blade)

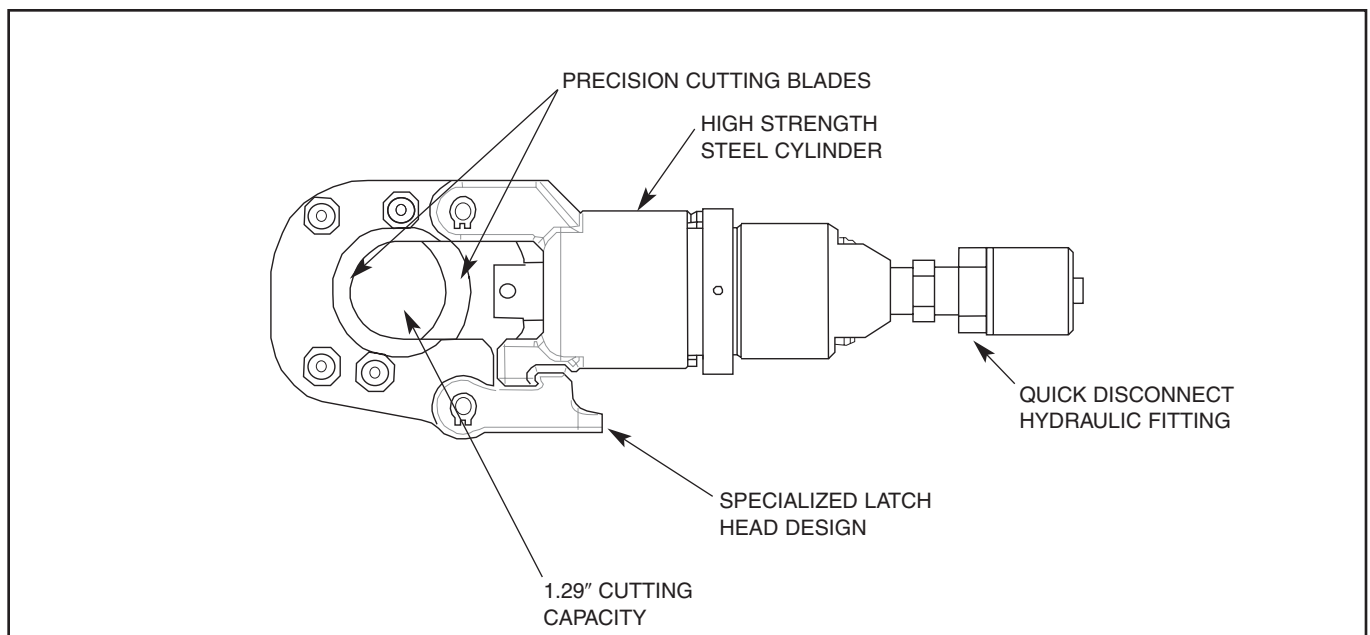

### TYPE RHCC245CUAL

#### 10,000 PSI Remote Cable Cutter

#### Remote Power Operated Hydraulic Cable Cutter

The BURNDY® RHCC245CUAL remote hydraulic cable cutter incorporates a specialized latch style cutting head that allows interference-free closure for mid-span cuts. The RHCC245CUAL with its precision cutting blades is capable of cutting up to 2.45" diameter copper and aluminum cable.

The RHCC245CUAL is provided with a 5-year limited warranty (excluding blades).



#### Features and Benefits

- Specialized latch head design.
  - ◇ Interference free closure for mid-span cuts.
- Precision cutting blades.
  - ◇ For clean cuts on copper and aluminum cable.
- High strength steel body.
  - ◇ For durability and long life
- Lightweight ergonomic design allows one hand operation.
  - ◇ User has one hand free to manipulate material to be cut.
- Durable canvas carrying bag.
  - ◇ Provides tool protection and stores all accessories.
- 5-year limited warranty on tool (excluding blades).
  - ◇ Customer satisfaction and support.

#### SPECIFICATIONS

**Operating Pressure:** 10,000 psi (700 bar)  
**Tool Weight:** 8.3 lbs (3.8 kg)  
**Length:** 14.8" (376 mm)  
**Width:** 4.75" (121 mm)

#### FOR USE ON

**Copper & Aluminum** 2.45" O.D. (62 mm)

#### ACCESSORIES

**Canvas Bag:** Cat# **PT10054094**

**Replacement Blades:** Cat# **PT10038657**  
(Moving Blade)

Cat# **PT10040663**  
(Fixed Blade)

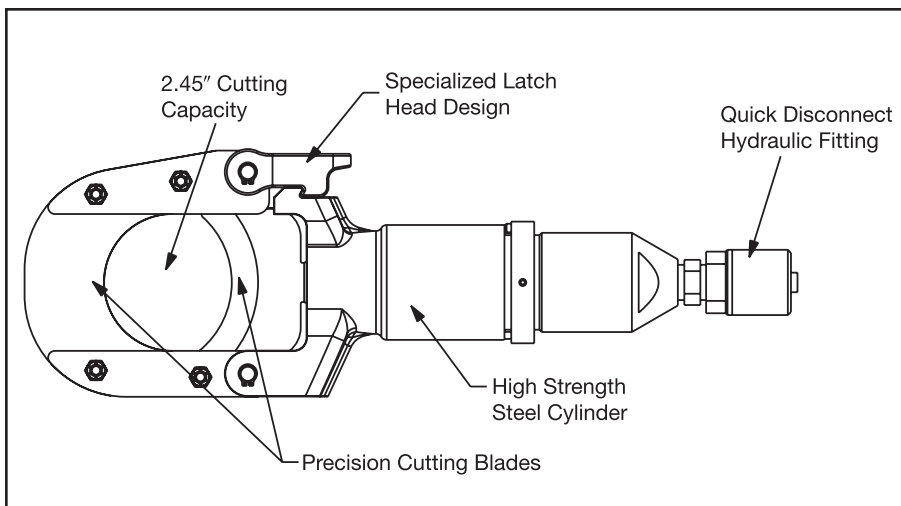

### TYPES MCC20, MCC500, MCC1000

#### MANUAL CABLE CUTTERS

The MCC series cable cutters are precision cable cutters incorporating high leverage shear-type design capable of cutting up to 1000 kcmil copper and aluminum cables. Rugged steel blades and fiberglass construction provide cutting ease, long life and minimum cable distortion. MCC20 has non-slip grip covered forged steel handles.

The MCC series cable cutters are warranted to be free from defects in material (excluding blades) and workmanship for one year.



#### FEATURES

- High quality design and construction.
- Rugged high quality steel blades.
- Fiberglass handles with soft grips.
- MCC20 has forged steel handles with non-slip grips.

#### BENEFITS

- Easy cutting with minimal cable distortion.
- Excellent cutting edge performance.
- Provides comfortable tool operation and long life.

Catalog Number	Overall Length	Max. Capacity		Max. Insulation Diameter	Weight
		Copper	Aluminum		
MCC20	9-1/4" [235 mm]	2/0 AWG [50 mm]	4/0 AWG [95 mm]	—	1 lb. (0.45 kg)
MCC500	21" [533 mm]	500 kcmil	500 kcmil	1.25" [32 mm]	3.5 lbs. (1.5 kg)
MCC1000	32" [813 mm]	1000 kcmil	1000 kcmil	1.90" [48 mm]	9.0 lbs. (4.0 kg)

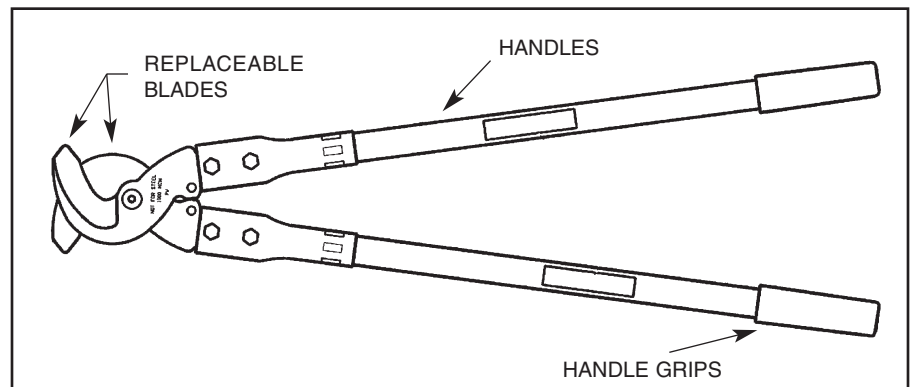

#### Replacement Blades

Catalog Number	Description
MCC500BLADESET	Replacement blades for MCC500
MCC1000BLADESET	Replacement blades for MCC1000

### TYPES RCC556, RCC600, RCC750HD, RCC954ACSR, RCC1000

#### RATCHET CABLE CUTTERS

The RCC series cable cutters are precision high quality tools designed to cut up to 954 ACSR and 1000 kcmil copper and aluminum. The tools are equipped with rugged steel blades, and a precision bi-directional ratchet mechanism for positive blade control, including where applicable, a fast action thumb slide collar for rapid blade advance and rugged fiberglass or non-slip grip handles. RCC600 and RCC750HD have cushion grip covered steel handles.

The RCC series cable cutters are warranted to be free from defects in material (excluding blades) and workmanship for one year.

**For replacement blades, consult factory for details.**

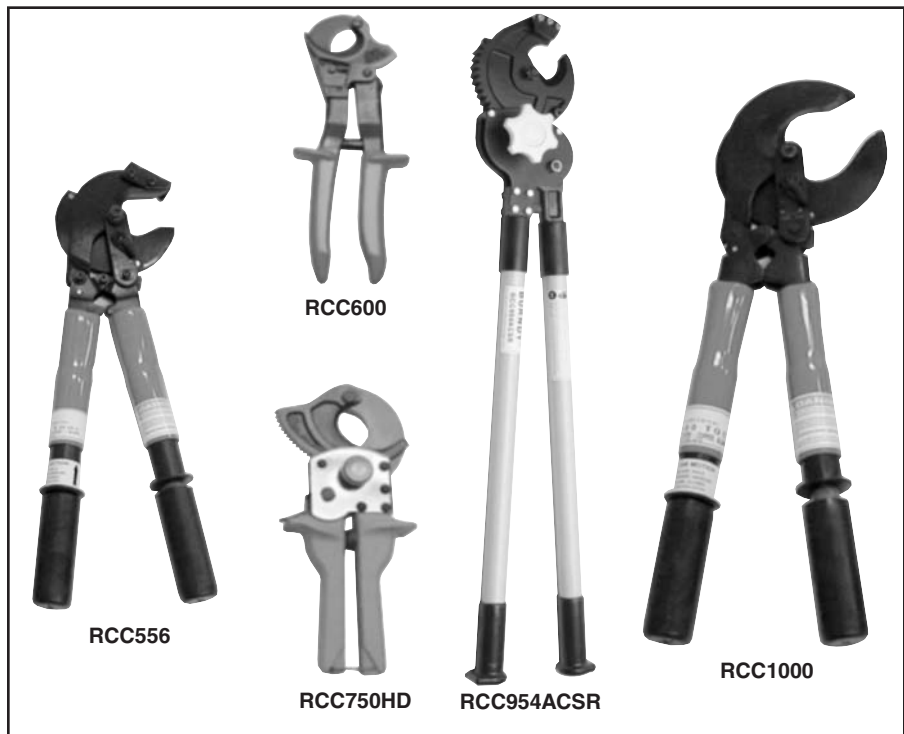

#### FEATURES

- Patented high strength steel blades.
- Quick release, bi-directional ratchet mechanism.
- Rapid blade advance.

#### BENEFITS

- Easy cutting with minimal cable distortion.
- Excellent cutting edge performance.
- Provides comfortable tool operation and long life.

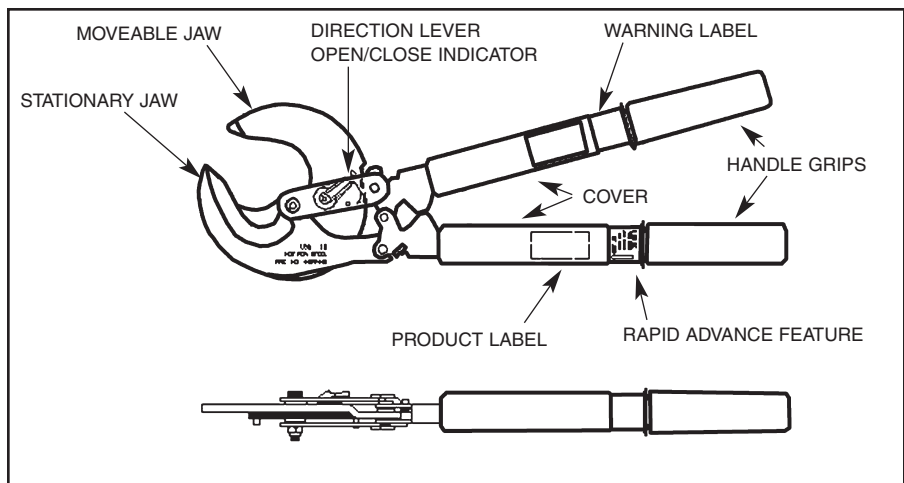

Catalog Number	Overall Length	Max. Capacity			Max. Insulation Diameter	Weight
		Copper	Aluminum	ACSR		
RCC556	21" [533 mm]	500 kcmil [32 mm]	500 kcmil [32 mm]	556 kcmil	1.25" [32 mm]	3.5 lbs. (1.5 kg)
RCC600	10" [255 mm]	600 kcmil [300 mm]	600 kcmil [300 mm]	—	1.25" [32 mm]	1.27 lbs. (.57 kg)
RCC750HD	10-1/2" [267 mm]	750 kcmil [500 mm]	750 kcmil [500 mm]	—	1.62" [42 mm]	2.43 lbs. (1.1 kg)
RCC954ACSR	36" [915 mm]	750 kcmil [500 mm]	750 kcmil [500 mm]	954 kcmil	1.54" [39 mm]	13 lbs. (6.0 kg)
RCC1000	32" [813 mm]	1000 kcmil [48 mm]	1000 kcmil [48 mm]	—	1.90" [48 mm]	9.0 lbs. (4.0 kg)



### TYPES HP10, HP8, AND HP6

#### HP SERIES MANUAL HYDRAULIC HAND PUMPS

HYDRAULIC OUTPUT PRESSURES OF: 10,000 PSI, 8,800 PSI, AND 6,000 PSI

Hand pumps are designed to match the output pressure requirements of HYPRESS™ heads and cutters. Each pump is equipped with a built-in, factory set pressure release valve with audible click to signal completion of crimp cycle.



#### BENEFITS

- Durable, long life expectancy.
- Easy to transport and move tool around job site with built in handle.
- Maximum mechanical advantage provided with long handle.
- Solid tool base provided with sturdy broad leg stabilizers.
- Save time with quick disconnect hydraulic fitting.
- High quality crimps provided with built-in, factory set pressure release valve and audible click to signal completion of crimp.
- 5-year limited warranty.

#### SPECIFICATIONS

Reservoir volume: 1-1/8 qts.  
 Length: 24-3/4"  
 Width: 5"  
 Weight: 18 lbs.  
 Closed height: 6-3/4"  
 Height (with handle open): 20"

#### FOR USE ON

**HP10** 10,000 Y34BH, Y35BH, Y35BH-4, Y750BH, Y750BH-2, Y39BH, Y45, Y46C, Y46, Y60BHU, RHCC Series Cutters

**HP8** 8,800 Y48BH

**HP6** 6,000 Y35-L, RHCC Series Cutters

#### ACCESSORIES

Extended leg pad stabilizes (w/hardware)  
 Cat # **BP10PADKIT**

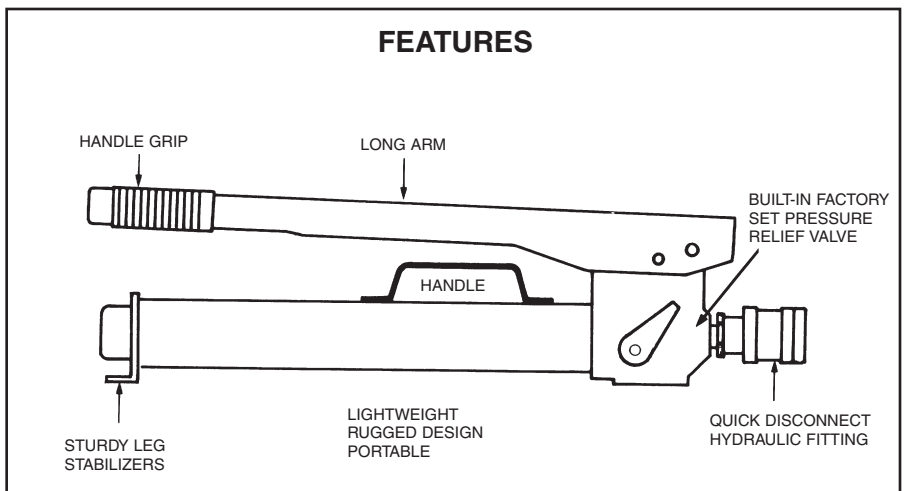

### TYPES FP10, FP8, AND FP6

#### FP SERIES MANUAL HYDRAULIC FOOT PUMPS

HYDRAULIC OUTPUT PRESSURES OF: 10,000 PSI, 8,800 PSI, AND 6,000 PSI

Foot pumps are designed to match the output pressure requirements for use with all HYPRESS™ heads and cutters. Each pump is equipped with a built-in, factory set pressure release valve with audible click to signal completion of a crimp cycle.



#### BENEFITS

- Easy to lift and carry.
- Durable. Long life expectancy.
- Easy to transport and move tool around job site with built in handle.
- Easy operation provided with spring assisted return arm.
- Maximum mechanical advantage provided with long arm extending beyond pump body.
- Quality, heavy duty foot pad provided with diamond plate steel.
- Solid tool base provided with sturdy broad leg stabilizers.
- Time saving quick disconnect hydraulic fitting.
- High quality crimps provided with factory set pressure release valve with audible click to signal completion of crimp.
- 5-year limited warranty.

#### SPECIFICATIONS

Reservoir volume: 1-1/8 qts.  
 Length: 24-3/4"  
 Width: 5"  
 Weight: 19 lbs.  
 Closed height: 6-1/2"  
 Height (with handle open): 17"

#### FOR USE ON

**FP-10** 10,000 Y34BH, Y35BH, Y35BH-4, Y750BH, Y750BH-2, Y39BH, Y45, Y46C, Y46, Y60BHU, Y750BH, RHCC Series Cutters

**FP-8** 8,800 Y48BH

**FP-6** 6,000 Y35-L, RHCC Series Cutters

#### ACCESSORIES

Extended leg pad stabilizes (w/hardware)  
 Cat # **BP10PADKIT**

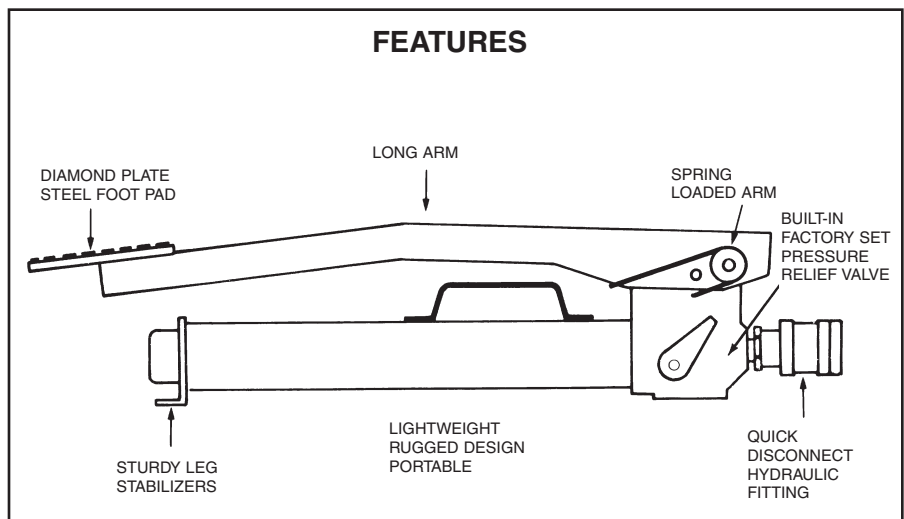

## TYPE EPP10 AND EPP6

### EPP SERIES ELECTRIC/ HYDRAULIC PUMP

HYDRAULIC OUTPUT  
PRESSURE OF:  
10,000 PSI AND 6,000 PSI

The lightweight and durable EPP10 electric/hydraulic pump is for use with all BURNDY HYPRESS™ remote heads and cutters requiring 10,000 PSI operating pressure. Both the EPP10 and the EPP6 are equipped with a built-in, factory set pressure relief valve. An audible “pop” and recycling of the pump and relaxing of the hose, signals completion of the crimping/cutting cycle. Both pumps are supplied with a durable hand-held electric pendant switch, for remote operation of the unit, and have a manual selection switch mounted for operation of the unit at the pump. The operator can select which method is best suited for the application.

An optional carry/shipping case can be ordered. All EPP Series pumps have been life cycle tested to over 100,000 cycles without failure, and are warranted to be free of defects in materials and workmanship for five (5) years when properly maintained and operated.



### FEATURES

- Lightweight.
- Small size.
- Factory set relief valve.
- 100,000 (+) life cycles.
- Sealed electric pendant switch.

### BENEFITS

- High quality crimps are achieved with built in, factory set pressure release valve and audible recycling of pump to signal completion of crimp cycle.
- Easy to lift, carry and transport tool around job site with lightweight body and handle.
- Convenient 115 V-AC electric powered motor.
- Durable remote pendant switch.
- Easy operation controlled with pendant switch, or manual switch.
- Saves time with quick disconnect hydraulic fitting.
- Long durable life expectancy with lightweight cast aluminum reservoir body.
- 5-year limited warranty.

### SPECIFICATIONS

Motor: 115 V-AC/60 Hz  
1/2 HP @ 3450 RPM

Maximum  
current draw: 12.5 amperes

Reservoir volume: 2 qts.

Height: 16”

Base: 6” × 8”

Weight: 30 lbs.

### FOR USE ON

**EPP10** 10,000 Y34BH, Y35BH, Y35BH-4,  
Y39BH, Y45, Y46, Y46C,  
Y60BHU, 750BH,  
Y750BH-2, Y644MBH,  
RHCC Series Cutters

**EPP6** 6,000 Y35L, Y28B, RHCC Series  
Cutters

### ACCESSORIES

Cat. No. **EPPCASE-1**

Steel carrying case with handle and locking latch.

## TYPES EPAC10, EPAC8, AND EPAC6

### EPAC SERIES ELECTRIC/ HYDRAULIC PUMP, AIR CONTROL

HYDRAULIC OUTPUT PRESSURES OF: 10,000 PSI, 8,800 PSI, AND 6,000 PSI

The EPAC10, EPAC8, and EPAC6 electrically driven hydraulic pumps feature exclusive automatic or manual "jog and hold" operation control provided by a unique air control switch, which provides the safest operation method of any pump available. All EPAC's are remotely controlled by an improved air control switch which electrically isolates the operator from the unit, and can be operated by either hand or foot activation. A three (3) position toggle switch mounted on the control box allows the operator to select either full automatic, off, or manual operation.

The automatic mode advances the remote tool into a "hold" position without crimping the connector so the operator can inspect the orientation before completing the crimp. Once the crimp is completed, the pump automatically turns the pump off, allowing the retraction of the remote tool and resets itself for the next operation.

The manual position allows the operator to jog the tool forward without the tool ram retracting. To retract the tool prior to completing the crimp, turn the control switch to "off," the pump will stop and the tool will retract. In the manual mode the pump advances only while the control is being depressed. To complete a crimp, squeeze and hold the air control switch until the pump reaches the pre-set pressure and shuts off.

The EPAC Series of electrically driven hydraulic pumps incorporate a heavy-duty roll cage design that is both rugged and portable. All EPAC Series pumps have been life cycle tested to over 100,000 cycles without failure, and are warranted to be free of defects in material and workmanship for five (5) years when properly maintained and operated.



## SPECIFICATIONS

Motor:	1/2 HP 115/230 V-AC, 60 Cycle
(EPAC**-2 versions):	1/2 HP 220/230 V-AC, 50 Cycle
Maximum current draw:	10 amperes
Reservoir volume:	8 quarts max, 2 quarts min
Height:	17-1/2"
Base:	11-3/4" × 18-1/2"
Dry weight:	68 lbs
	(82 lbs w/max fluid)
	(1/2 HP @ 3450 RPM)

## FEATURES

- Roll cage
- 3 position switch and control box
- Factory set output pressure
- Quick disconnect hydraulic coupler
- Oil level window
- 8 quart reservoir

## BENEFITS

- Permits final inspection of connector before completing crimp cycle.
- Extra supply hydraulic fluid 8-quart reservoir.
- Full automatic or manual "Jog and Hold" cycles.
- Operator safety with power loss "smart circuit," freezes unit in event of power disruption.
- Method of operation desired is permitted with 3-position selection switch.
- Safety is provided against hazardous shock with airbulb actuator and air line.
- Saves time with quick disconnect hydraulic fitting.
- Windows allows easy inspection of proper oil level.
- High quality crimps are achieved with built-in factory set pressure release valve.
- 5-year limited warranty.

## FOR USE ON

<b>EPAC10</b>	10,000	Y34BH, Y35BH, Y35BH-4, Y39BH, Y45, Y46, Y46-C, Y60BHU, Y750BH, Y750BH-2, Y644MBH, RHCC Series Cutters
<b>EPAC-8</b>	8,800	Y48BH
<b>EPAC-6</b>	6,000	Y35L, RHCC Series Cutters

### TYPES EP10, EP8, EP6 AND EP10-2, EP8-2, EP6-2

#### EP SERIES ELECTRIC/ HYDRAULIC PUMPS

HYDRAULIC OUTPUT PRESSURES OF 10,000 PSI, 8,800 PSI, AND 6,000 PSI

Electrically driven hydraulic pumps are supplied with a durable, hand-held electric pendant switch that remotely controls the pump and matches the output requirements of all HYPRESS™ remote heads and cutters. Each pump is equipped with a built-in, factory set, pressure relief valve. An audible “pop” and recycling of the pump and relaxing of the hose, signals completion of the crimping/cutting cycle.

All EP series pumps are supplied with 115/230 - 220/230 voltage, 60/50 hertz, 1/2 horsepower motor and can be wired for use with any electric power source worldwide. A three prong, grounded plug is wired standard on the units. All EP Series pumps have been life cycle tested to over 100,000 cycles without failure, and are warranted to be free of defects in materials and workmanship for five (5) years when properly maintained and operated.



#### SPECIFICATIONS

Motor:	1/2 HP 115/230 V-AC, 60 cycle
(EP**-2 versions):	1/2 HP 220/230 V-AC, 50 cycle
Maximum current draw:	10 amperes
Reservoir volume:	8 quarts max, 2 quarts min
Height:	17-1/2"
Base:	11-3/4" × 18-1/2"
Dry weight:	68 lbs (86 lbs with max fluid)
	(1/2 hp @ 3450 rpm)

#### BENEFITS

- Provides fast sure pump action plus a long life expectancy.
- It's portable. Roll cage allows easy moving on the job site.
- Durable 1/2 HP dual voltage motor.
- Extra supply of hydraulic fluid with 8 quart reservoir.
- Saves time with quick-disconnect hydraulic fitting.
- Easy operator control is provided with remote pendant switch.
- Easy inspection of proper oil level is provided by see through window.
- High quality crimps are achieved with built-in, factory set, pressure release valve and audible recycling of pump which signals completion of crimp.
- 5-year limited warranty.

#### FOR USE ON

<b>EP10</b>	10,000	Y34BH, Y35BH, Y35BH-4, Y39BH, Y45, Y46, Y46-C, Y60BHU, Y750BH, Y750BH-2, RHCC Series Cutters
<b>EP8</b>	8,800	Y48BH
<b>EP8-2</b>		
<b>EP6</b>	6,000	Y35L, RHCC Series Cutters
<b>EP6-2</b>		

#### FEATURES

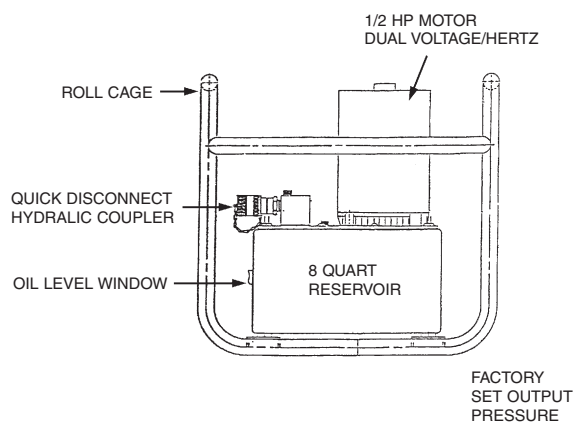

### TYPES EP10-1HP, EP8-1HP, EP6-1HP AND EP10-1HP-2, EP8-1HP-2, EP6-1HP-2

#### EP-1HP SERIES ELECTRIC/ HYDRAULIC PUMPS

HYDRAULIC OUTPUT  
PRESSURES OF:  
10,000 PSI, 8,800 PSI,  
AND 6,000 PSI

Heavy duty electrically driven hydraulic pumps are supplied with a durable, hand-held electric pendant switch that remotely controls the pump and matches the output requirements of all HYPRESS™ remote heads and cutters. Each pump is equipped with a built-in, factory set, pressure relief valve. An audible “pop” and recycling of the pump and relaxing of the hose, signals completion of the crimping/cutting cycle.

All EP-1HP series pumps are supplied with 115/230 - 220/230 voltage, 60/50 hertz, 1 horsepower motors and can be wired for use with any electric power source worldwide. A three prong, grounded plug is wired standard on the units. All EP-1HP Series pumps have been life cycle tested to over 100,000 cycles without failure, and are warranted to be free of defects in materials and workmanship for five (5) years when properly maintained and operated.



#### FEATURES

- Heavy duty design.
- Roll cage.
- Quick disconnect hydraulic coupler.
- Oil level window.
- 8 quart reservoir.
- Factory set output pressure.
- 1 HP motor dual voltage/hertz.

#### BENEFITS

- Provides fast sure pump action plus a long life expectancy.
- Its portable roll cage allows easy moving on the job site.
- Strong durable motor provided with (1) H.P. dual voltage design.
- Extra supply of hydraulic fluid with 8 quart reservoir.
- Saves time with quick-disconnect hydraulic fitting.
- Easy operator control is provided with remote pendant switch.
- Easy inspection of proper oil level is provided by see through window.
- High quality crimps are achieved with built-in, factory set, pressure release valve and audible recycling of pump which signals completion of crimp.
- 5-year limited warranty.

#### SPECIFICATIONS

Motor:	1/2 HP 115/230 V-AC, 60 cycle
(EP**-2 versions):	1/2 HP 220/230 V-AC, 50 cycle
Maximum current	
draw:	10 amperes
Reservoir volume:	8 quarts max, 2 quarts min
Height:	17-1/2"
Base:	11-3/4" × 18-1/2"
Dry weight:	68 lbs (86 lbs with max fluid)
	(1/2 hp @ 3450 rpm)

#### FOR USE ON

<b>EP10-1HP</b>	10,000	Y34BH, Y35BH, Y35BH-4, Y39BH, Y45, Y46, Y46-C, Y60BHU, Y750BH, Y750BH-2, RHCC Series Cutters
<b>EP8-1HP</b>	8,800	Y48BH
<b>EP8-1HP-2</b>		
<b>EP6-1HP</b>	6,000	Y35L, RHCC Series Cutters
<b>EP6-1HP-2</b>		



### TYPES GP10, GP8, AND GP6

#### GP SERIES GASOLINE ENGINE DRIVEN HYDRAULIC PUMP

HYDRAULIC OUTPUT PRESSURES OF: 10,000 PSI, 8,800 PSI, AND 6,000 PSI

The GP series gasoline engine driven hydraulic pump is a heavy-duty design that is rugged and portable. Supplied with a four (4) H.P. engine, the pump operates all BURNDY® remote compression heads and cable cutters.

All GP style pumps have a built-in, factory pre-set, automatic pressure release overload valve with a definite pulsing and recycling to signal the completion of a crimp. The manual control valve allows user to "Jog and Hold" due to the unique check valve design that keeps pressure in the output line until retracted.



#### BENEFITS

- Portable pump with sturdy steel roll cage.
- Durable heavy-duty four (4) H.P. engine for all HYPRESS™ applications and long life expectancy.
- Manual control valve permits easy control of crimping or cutting operations.
- Manual control valve permits easy control of crimping or cutting operations.
- Fast hose assembly with quick disconnect pressure matched hydraulic couplers.
- Ample hydraulic capacity with (8) quart reservoir.
- 5-year limited warranty.

#### Specifications

Engine: 4 H.P., 4 cycle  
 Reservoir volume: 2 gallons (8 qts.)  
 Pump height: 19-3/4"  
 Pump width: 13"  
 Pump length: 18"  
 Overall height: 22-1/4"  
 Overall width: 16"  
 Overall length: 21"  
 Pump and motor dry weight: 64-1/4 lbs.  
 Overall dry weight: 77-3/4 lbs.

#### FOR USE ON

Pump	PSI	Hydraulic Tools and Cutter
GP10	10,000	Y34BH, Y35BH, Y35BH-4, Y39BH, Y45, Y46, Y46C, Y60BHU, Y60BHU-D, Y750BH, Y750BH-2, RHCC Series Cutters
GP8	8,800	Y48BH
GP6	6,000	Y35L, RHCC Series Cutters

#### FEATURES

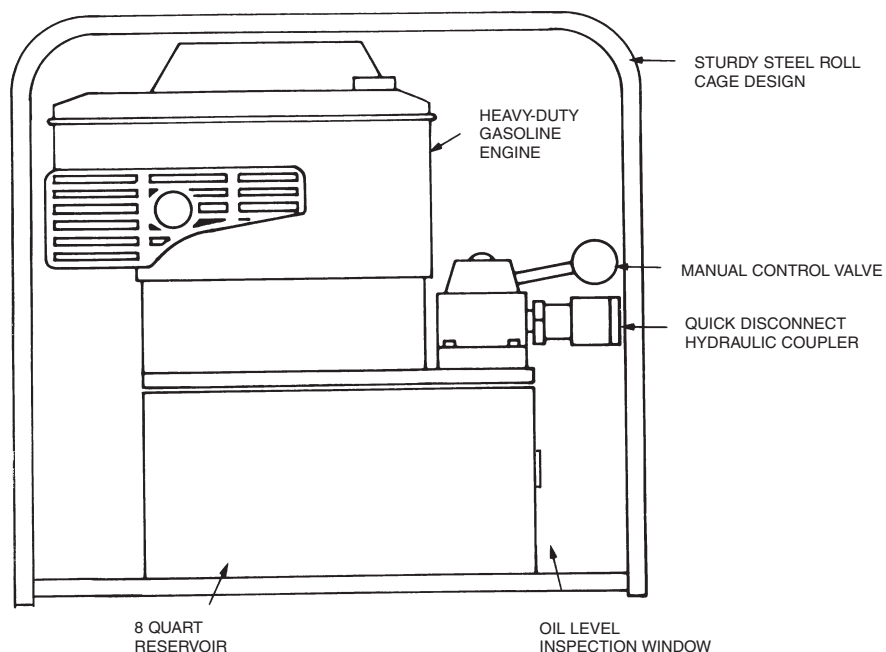

### HYDRAULIC HOSES

#### NON CONDUCTIVE HOSES\*



**10,000 PSI**

Cat. No.	Description
<b>PT 29900-10</b>	10' - 3/16" diameter - non conductive hose with stackable couplers (male/female) - orange
<b>PT 29900-15</b>	15' - 3/16" diameter - non conductive hose with stackable couplers (male/female) - orange
<b>PT 29900-25</b>	25' - 3/16" diameter - non conductive hose with stackable couplers (male/female) - orange
<b>PT 29901-10</b>	10' - 1/4" diameter - non conductive hose with stackable couplers (male/female) - orange
<b>PT 29901-15</b>	15' - 1/4" diameter - non conductive hose with stackable couplers (male/female) - orange
<b>PT 29901-25</b>	25' - 1/4" diameter - non conductive hose with stackable couplers (male/female) - orange

**NOTE:** 1/4" diameter hose provides higher flow rate for faster ram movement.

\* For proper care and maintenance of hydraulic hoses, consult the "Hydraulic Hose Care" manual, Form No. 7828

#### NON CONDUCTIVE HOSES\*



**6,000 PSI**

Cat. No.	Description
<b>PT 29902-10</b>	10' - non conductive hose with stackable couplers (male/female) - orange
<b>PT 29902-15</b>	15' - non conductive hose with stackable couplers (male/female) - orange
<b>PT 29902-25</b>	25' - non conductive hose with stackable couplers (male/female) - orange
<b>PT 29074-1</b>	Non conductive hose carrying bag

\* For proper care and maintenance of hydraulic hoses, consult the "Hydraulic Hose Care" manual, Form No. 7828

#### CONDUCTIVE HOSES\*

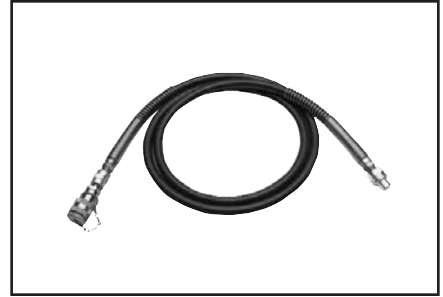

**10,000 PSI**

Cat. No.	Description
<b>PT 91</b>	8' - steel braided hose with steel spring reinforced ends. Stackable couplers (male/female) - Black. No electrical rating. DO NOT use on energized conductor.

**8,800 PSI**

Cat. No.	Description
<b>PT 76</b>	8' - steel braided hose with steel spring reinforced ends. Stackable couplers (male/female) - Black. No electrical rating. DO NOT use on energized conductor.

\* For proper care and maintenance of hydraulic hoses, consult the "Hydraulic Hose Care" manual, Form No. 7828.



**Do not attempt to repair or recouple the hose yourself!**

### ACCESSORIES



#### PT 29074-1 Insulated hose carrying bag

Designed to provide protection and cleanliness of non conductive hoses. Accommodates 100 ft. of non conductive coiled to 17-1/2" O.D. and 3-3/4" wide. Max. carrying capacity: 10 lbs.



Adjustable Head Grip For joining HYPRESS™ heads to universal hot sticks  
**PT 29075** (for Y35L)  
**PT 29402-1** (for Y35BH)  
**PT 6547-2** (for Y45)  
**PT 10128** (for Y46)  
**PT 10131** (for Y46C)



#### ALFLUID

##### ALFLUID QT. ALFLUID GAL.

(available in quart and gallon size containers)

Use ALFLUID™ in hand operated tools during extended use below 32 degrees.

All weather HYDRAULIC fluid for BURNDY® pumps:

- HP hand pump
- FP foot pump
- GP gasoline pump

- EPP. electric pump
- AC-3H auto/man. elect. pump
- DC-3H auto/man. elect. pump



Replacement Coupler 6,000 psi operating pressure

- PT 29091** (male)
- PT 29214-1** (female)

#### Pressure Tee\*

- Y106PSI** (10,000 to 6,000 p.s.i.)
- Y108PSI** (10,000 to 8,800 p.s.i.)

Allows use of 10,000 p.s.i. pumps in conjunction with BURNDY® 6,000 p.s.i. and 8,800 p.s.i. HYPRESS™ tools.

\* For proper care and maintenance of hydraulic hoses, consult the "Hydraulic Hose Care" manual, Form No. 7828

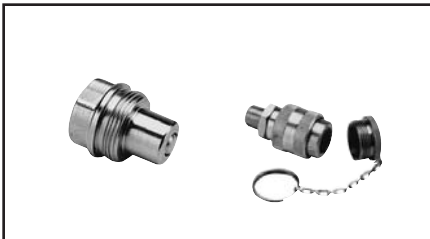

Replacement Coupler 10,000 psi operating pressure

- PT 94** (male)
- PT 93** (female)



#### HYFLUID

##### HYFLUID QT. HYFLUID GAL.

(available in quart and gallon size containers)

Hydraulic fluid for BURNDY® HYPRESS™ hand operated tools:

- Y35 and Y35-2 HYPRESS™ tools
- Y39 HYPRESS™ tool
- Y750 REVOLVER HYPRESS™ tools



#### DIE CASES

##### PT 29291

(Y750, Y35/Y39) die case for "U" -type die sets

##### PT 6545

(Y45 and Y46) die case for "S" and "P" -type die sets



In-line Pressure Gauge 10,000 psi operating pressure for hydraulic pumps

#### PT 11018

#### TOOL

- Y35 HYPRESS™
- Y35-2, Non Conductive version Y35
- Y39 HYPRESS™
- Y750 & Y750-2, Revolver HYPRESS™
- Y644M, Die-less HYPRESS™ (Y644 tool, obsolete)
- Y35BH, 12 Ton Remote Y35
- Y35BH-4, Non Conductive Y35BH tool
- Y39BH, 12 Ton Remote Y39
- Y750BH, 12 Ton Remote Y750
- Y750BH2, Non Conductive Y750BH

#### TOOL CARRY CASE CAT#

- #PT2972** - Steel w/ 13 die holder tray
- #PT29360** - Steel w/ 13 die holder tray
- #PT12814** - Steel w/ 13 die holder tray
- #PT23490** - Steel w/ 13 die holder tray
- #PT30539** - Steel case, no die holder tray (#PT30007 - Steel carry case)
- #PT29413** - Steel w/ 6 die holder tray
- N/A, (use Y50BH-2 case, #PT23607)
- #PT12821** - Steel w/ 6 die holder tray
- #PT23492** - Steel w/ 6 die holder tray
- #PT23607** - Steel w/ 6 die holder tray

#### TOOL

- Y644MBH, Die-less remote
- Y45, 15 Ton Remote HYPRESS
- Y45, 15 Ton Remote HYPRESS (Y45L-1, old style press)
- Y46, 15 Ton Remote HYPRESS
- Y46C, Non Conductive version Y46
- Y60BHU, 60 Ton Remote HYPRESS
- Y29BH, Remote HYPRESS
- FP/HP Series Foot & Hand Pumps (new style pumps)

#### TOOL CARRY CASE CAT#

- #PT207190-01** - Steel, no die holder
- #411-206016-014** - Steel, 1 die holder
- #411-206091-018** - Steel, w/ 1 die holder (#PT6573 - Steel, w/ 1 die holder)
- #433-206016-010** - Steel, w/ 1 die holder
- #433-206071-012** - Steel, w/ 1 die holder
- #PT22648** - Steel, no die holders
- #PT30250** - Steel, w/ die holder
- #PT8** - Steel, fits Pump, Hose, and Head

### TYPE RK147-2

#### CONSTRUCTION/ MAINTENANCE WIRE STRIPPERS

These two lightweight strippers feature precision ground blades that give a precise and rapid strip for small wire applications. The RK190-2 has precise stripping grooves for #10-#20 AWG solid and a copper wire cutting blade. The RK147-2 is an adjustable stripper cutter with a simple cam screw adjustment for multi-varied wire sizes and insulation thickness up to #12 AWG solid or stranded wire. Both tools are part of BURNDY's convenience package program and are shipped on merchandising rack cards.



#### RK147-2

Wire Stripping Range: No minimum,  
up to #12 AWG  
Overall Length: 5.31"  
Weight: .18 lbs.

### WIRE MIKE

#### RK 194-2

The wire mike is a useful instrument designed for measuring ACSR, stranded and solid conductors, I.P.S. tubing, rigid and thinwall conduit, plus inside and outside dimensions of tubing and pipe sizes. A ruler is also included.

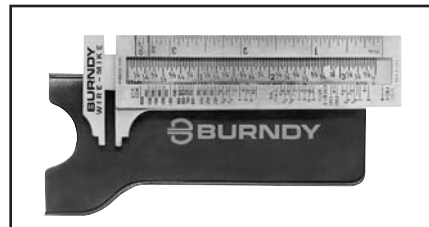

#### FOR USE ON:

- ACSR: #6 - 336.4 (26/7) str.
- Stranded: #18 str. - 2,000 kcmil
- Solid: #20 sol. - 4/0 sol.
- IPS Tubing (Cu/Al) &  
Rigid conduit: 1/4" - 2-1/2"
- Tubing sizes: 3-11/8" inside max.  
2-15/16" outside max.
- Thinwall conduit: 3/8" - 2-1/2"

#### BENEFITS:

- Provides quick and easy identification of commonly used conductors (ACSR, stranded and solid AWG).
- Provides quick and easy identification of IPS tubing and rigid conduit.
- Provides quick and easy identification of thinwall conduit.
- Measures I.D. and O.D. of tubing.
- Provides easy conversion of information.
- Strong, durable, long lasting, high quality stainless steel wire mike.
- Convenient size makes it easy to carry.
- Available with your company name and logo. Customer must supply camera ready artwork. Contact BURNDY® for details. Minimum order required.

### Y29NC

#### PNEUMATIC HYPRESS™

The Y29NC Pneumatic HYPRESS™ operates on 85-100 PSI and will install insulated and uninsulated terminals from #8-2/0 copper. Uses DV type nest with Y29 type indenter.



#### BENEFITS

- Portable or bench mounted.
- Adjustable blow off valve to insure proper indenting force.
- Uses DV type nest with Y29 type indenter.
- Hand operated.
- 5-year limited warranty.

#### SPECIFICATIONS

Weight: 12-1/2 lbs.  
 Length: 17-1/2"  
 Air line pressure: 85 – 100 psi

#### FOR USE ON

Wire Range: #8–2/0 Cu  
 YAEV-L, YAEV-H, YAEV-RS, YAEV-RH,  
 YAV-L, YAV-R  
 YAV-RS, YSV-L, YSM

#### DIE INDEX NEST/INDENTER

38/631	DV8L/Y29PL
6/631	DV8L/Y29PL
39/632	DV6LY29PL
7	D6CL/Y29PL
40/633	DV4L/Y29PL
9	D3CL/Y29PR
41/634	DV2CL/Y29PL
42	DVIL/Y29PR
43	DV256/Y29PR
13	D26L/Y29PR
44	DV26L/Y29PR
49	DV8L/Y29PL

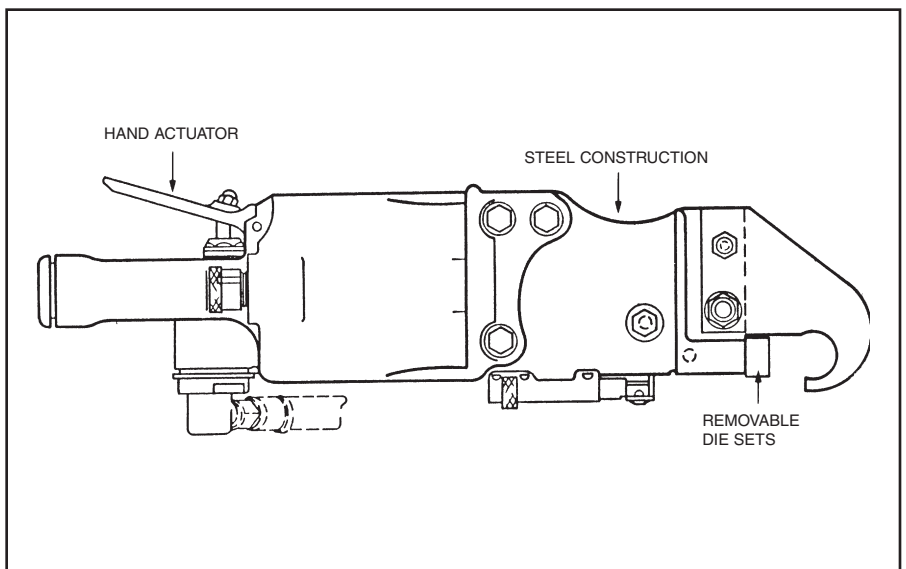

## TFM-TAPE FED MACHINE

### FOR AUTOMATIC INSTALLATION OF TAPE MOUNTED TERMINALS

The BURNDY® TFM machine installs vinyl insulated, nylon insulated and uninsulated terminal sizes #26-#10 without time-consuming die changes. A rotating turret die holder consists of three die sets. With the new TFM, your operators can crimp from 1,500 to 2,500 terminals per hour.

BURNDY® has made a breakthrough in die changing-the TFM is the first and only turret die holder to crimp terminals automatically. No long complicated setups or paying for duplicate machines: Once the dies are secure to the die holder there's never a need to remove them. No adjustments. No calibrations. Just a simple twist of the wrist. An operator can change reels, terminals and dies in seconds flat.



### SPECIFICATIONS

Height: 16"  
Width: 13"  
Depth: 6"  
Weight: 35 lbs.

### FOR USE ON

#26 - #10 AWG Cu

**VINYL INSULATED TERMINALS:**  
BA-EF-M, BA-EL-M, BA-EM, BA-EZ-M

**NYLON INSULATED TERMINALS:**  
YAE-M, YAE-FM, YAE-ZM

**NON-INSULATED TERMINALS:**  
YAD-M, YAD-FM

**VINYL INSULATED DISCONNECTS:**  
PQ-M

### FEATURES

- Positive wire locator.
- Foot-actuated crimp.
- Lightweight Reel.
- Quiet operation.
- Lease policy.
- Can crimp up to 1,500 to 2,500 terminals per hour.
- An operator can change reels, terminals and dies in 30 seconds.
- Rotating turret die holder permits terminal change over in seconds.

### BENEFITS

- Ensures proper wire termination.
- Minimizes repetitive hand motion injuries.
- Smooth rotation advance of connectors.
- Eliminates need for earplugs/noise dampeners.
- Inexpensive alternative to buying.
- High volume production capability.
- Minimizes production downtime.

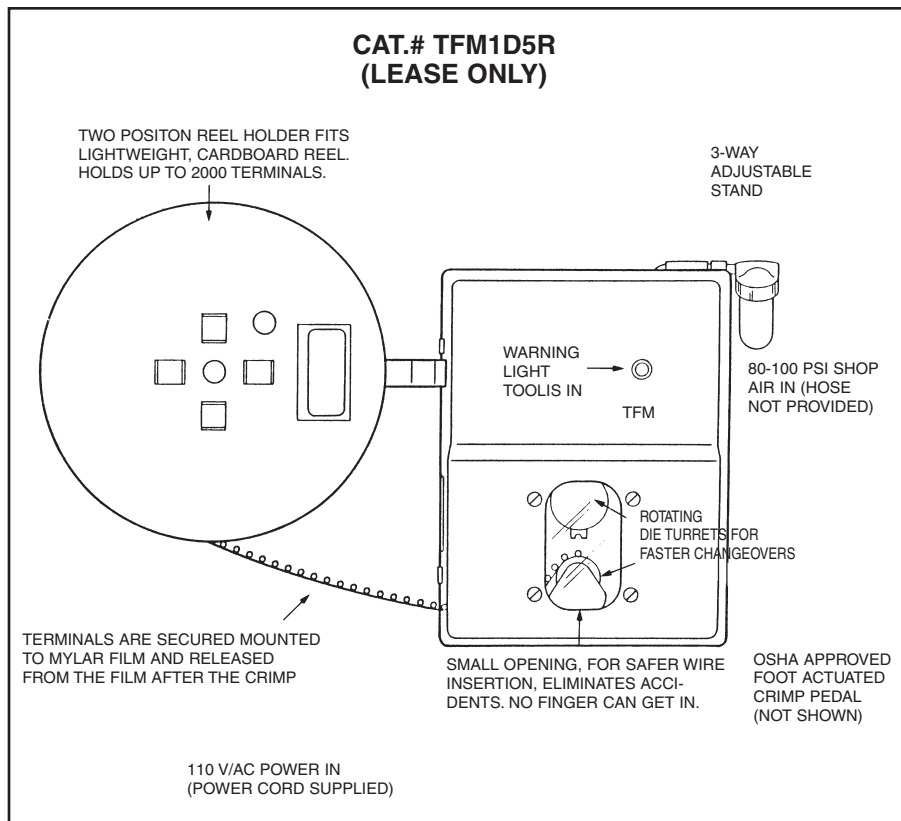



### TFM INSTALLATION TOOLING CHART

TAPE MOUNTED CATALOG NO. 2000/REEL	INSTALLATION TOOLING
BA16E4M	TFM with DFM3-1 Die
BA16E6M	
BA16E8M	
BA16E10M	
BA16E14M	
BA16E38M	
BA14E4M	TFM with DFM2-1 Die
BA14E6M	
BA14E8M	
BA14E10M	
BA14E14M	
BA14E16M	
BA14E38M	TFM with DFM1D5 Die
*BA10E6M	
*BA10E8M	
*BA10E10M	
*BA10E14M	
*BA10E38M	

BA16EF2M	TFM with DFM3-1 Die
BA16EF6M	
BA16EF8M	
BA16EF10M	
BA14EF2M	TFM with DFM2-1 Die
BA14EF6M	
BA14EF8M	
BA14EF10M	
*BA10EF6M	TFM with DFM1D5 Die
*BA10EF8M	
*BA10EF10M	

BA16EL6M	TFM with DFM20D1 (20-22 AWG) DFM3-1 (16-10 AWG)
BA16EL8M	
BA16EL10M	
BA14EL6M	TFM with DFM2-1 DIE
BA14EL8M	
BA14EL10M	
*BA10EL6M	TFM with DFM1D5 Die
*BA10EL8M	
*BA10EL10M	

\* 1000 per Reel

TAPE MOUNTED CATALOG NO. 2000/REEL	INSTALLATION TOOLING
YAD18-4M	TFM with DFM6-1 Die
YAD18-6M	
YAD18-8M	
YAD18-10M	
YAD18-14M	
YAD18-516M	
YAD18-38M	TFM with DFM5D1 Die
YAD14-4M	
YAD14-6M	
YAD14-8M	
YAD14-10M	
YAD14-14M	
YAD14-516M	TFM with DFM4D1 Die
YAD14-38M	
*YAD10-6M	
*YAD10-8M	
*YAD10-10M	
*YAD10-14M	TFM with DFM11D1 Die
*YAD10-516M	
*YAD10-38M	

YAE22N65FM	TFM with DFM11D1 Die
YAE22N66FM	
YAE18N60FM	TFM with DFM10D1 Die
YAE18G43FM	
YAE18N56FM	
YAE18N57FM	TFM with DFM9D1 Die
YAE14N76FM	
YAE14N77FM	
YAE14N78FM	

\* 1000 per Reel

TAPE MOUNTED CATALOG NO. 2000/REEL	INSTALLATION TOOLING
YAE22G18M	TFM with DFM11D1 Die
YAE22G12M	
YAE22G16M	
YAE22G13M	
YAE22G14M	
YAE22G15M	
YAE18N29M	TFM with DFM10D1 Die
YAE18N27M	
YAE18-N7M	
YAE18N17M	
YAE18N26M	
YAE18N21M	
YAE18N25M	
YAE18G43M	
YAE-18N24M	
YAE18N1M	
YAE18NM	TFM with DFM9D1 Die
YAE18N2M	
YAE18N3M	
YAE14N43M	
YAE14N1M	
YAE14NM	TFM with DFM7D1 Die
YAE14N2M	
YAE14N3M	
YAE14N4M	
YAE12N7M	
YAE12N9M	
YAE12N1M	
YAE12NM	
YAE12N2M	
YAE12N3M	
*YAE10N5M	TFM with DFM12D1 Die
*YAE10N11M	
*YAE10NM	
*YAE10N3M	
*YAE10N2M	TFM with DFM16D1 Die
*YAE10N4M	

\* 1000 per Reel

TAPE MOUNTED CATALOG NO. 2000/REEL	INSTALLATION TOOLING
YAE22Z1M	TFM with DFM11D1 Die
YAE22Z2M	
YAE22Z3M	
YAE18Z1M	TFM with DFM10D1 Die
YAE18Z2M	
YAE18Z3M	
YAE18Z4M	TFM with DFM9D1 Die
YAE14Z2M	
YAE14Z3M	TFM with DFM7D1 Die
YAE14Z4M	
YAE12Z2M	TFM with DFM7D1 Die
YAE12Z3M	
YAE12Z4M	

BA16EZ2M	TFM with DFM3-1 Die
BA16EZ6M	
BA16EZ8M	
BA16EZ10M	TFM with DFM2-1 Die
BA14EZ2M	
BA14EZ6M	
BA14EZ8M	TFM with DFM1D5 Die
BA14EZ10M	
*BA10EZ6M	
*BA10EZ8M	TFM with DFM1D5 Die
*BA10EZ10M	

PQ18R257M	TFM with DFM13D1 Die
PQ18R258M	
PQ14R257M	TFM with DFM12D1 Die
PQ14R258M	
PQ10R258M	TFM with DFM16D1 Die

PQ18R256M	TFM with DFM15D1 Die
PQ14R256M	TFM with DFM14D1 Die

PQ18R187M	TFM with DFM13D1 Die
PQ18R188M	
PQ14R187M	TFM with DFM12D1 Die
PQ14R188M	

\* 1000 per Reel