

- NOTES:
1. PACKAGE CABLE ASSEMBLY IN BAG, TAG IN BAG WITH "AMPHENOL CONNEX, 336312-12-XXXX AND DATE CODE".
 2. CABLE ASSEMBLY TO BE 100% TESTED FOR CONTINUITY, SHORTS AND OPEN.

336312-12-XXXX		REVISIONS			
DRAWING NO.	REV	DESCRIPTION	DATE	ECO	APPR
THIRD ANGLE PROJ.	A	RELEASE TO MFG.	09-Feb-11	--	RAK

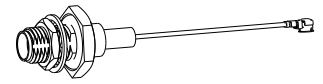

SCALE 1.500

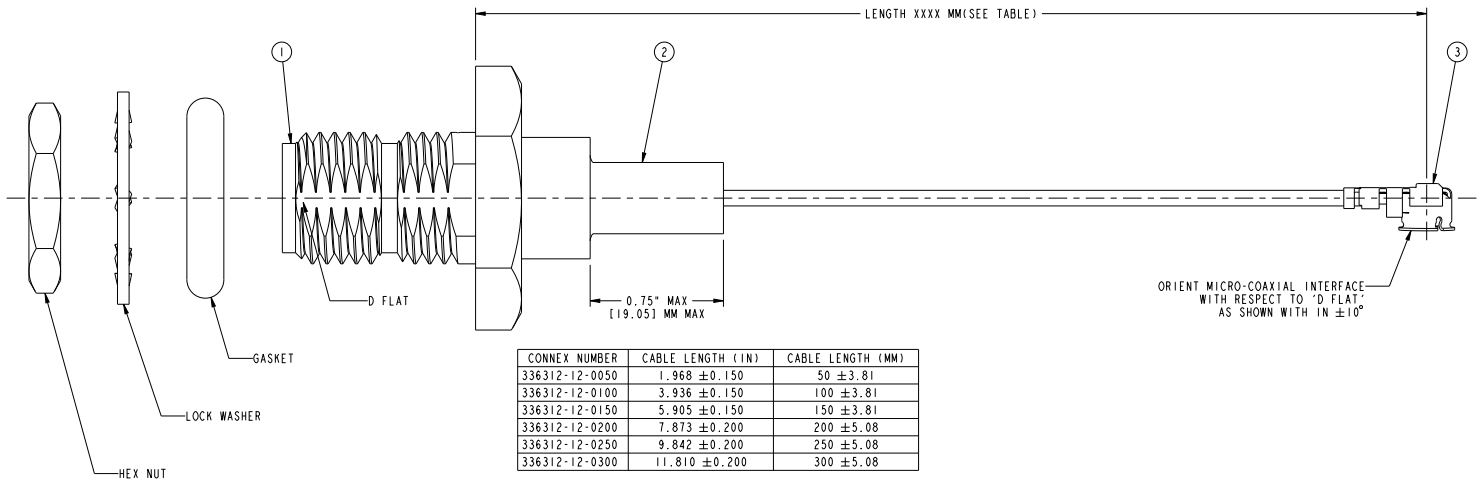

CONNEX NUMBER	CABLE LENGTH (IN)	CABLE LENGTH (MM)
336312-12-0050	1.968 ±0.150	50 ±3.81
336312-12-0100	3.936 ±0.150	100 ±3.81
336312-12-0150	5.905 ±0.150	150 ±3.81
336312-12-0200	7.873 ±0.200	200 ±5.08
336312-12-0250	9.842 ±0.200	250 ±5.08
336312-12-0300	11.810 ±0.200	300 ±5.08

* ADDITIONAL LENGTHS CAN BE PROVIDED BY CHANGING XXXX TO DESIRED LENGTH IN MM CONTACT CONNEX MARKETING FOR QUOTE

DESIGN REQUIREMENTS:

<input type="checkbox"/> FREQUENCY..... TO GHz	<input checked="" type="checkbox"/> CONTINUITY
<input type="checkbox"/> VSWR : 1 MAX	<input checked="" type="checkbox"/> HI-POT :200 VRMS
<input type="checkbox"/> INS. LOSS dB MAX	<input type="checkbox"/> OTHER

PART NUMBER	QTY	ITEM	DESCRIPTION	FINISH
100901-02	1	3	MICRO COAX R/A PLUG TERMINATED TO 1.13 MM CABLE	
009-954-458	A/R	2	HEAT SHRINK TUBE	
132422 RP	1	1	SMA BLKHD CRIMP JACK IP 67 RP	

UNLESS OTHERWISE SPECIFIED, DIMENSIONS ARE IN INCHES AND TOLERANCES ARE: 2 PLACE DECIMAL ±.015 (0,381 mm) 3 PLACE DECIMAL ±.005 (0,127 mm) ANGLES ± 1°	MATERIAL	DRAWN ABHAYA KISHORE	DATE 09-Feb-11	TITLE SMA BLKHD CRIMP JACK IP 67 RP TO MICRO COAX R/A PLUG TERMINATED TO 1.13MM CABLE, XXXX MM, LENGTH	Amphenol Connex			
	REFERENCE TASK - 568	ENGINEER ABHAYA KISHORE	DATE 09-Feb-11					
NOTICE - These drawings, specifications, or other data (1) are, and remain the property of Amphenol Corp. (2) must be returned upon request; and (3) are confidential and not to be disclosed to any person other than those to whom they are given by Amphenol Corp. The furnishing of these drawings, specifications, or other data by Amphenol Corp., or to any other person for any purpose is not to be regarded by implication or otherwise in any manner licensing, granting rights or permitting such holder or any other person to manufacture, use or sell any product, process or design, patented or otherwise, that may in any way be related to or disclosed by said drawings, specifications, or other data.		APPROVED	DATE	CAD FILE Root folder:/Cable assembly/336312-12-XXXX	DWG SIZE B	DRAWING NO. 336312-12-XXXX	SCALE: 5.0:1 SHEET 1 OF 1	REV A