

PRODUCT NO.
SEE TABLE

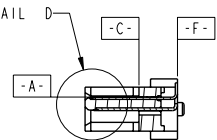

DETAIL G
SCALE 5:1

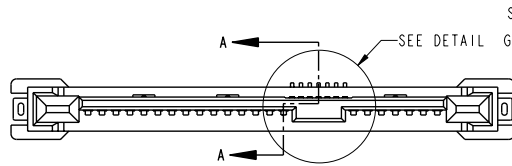
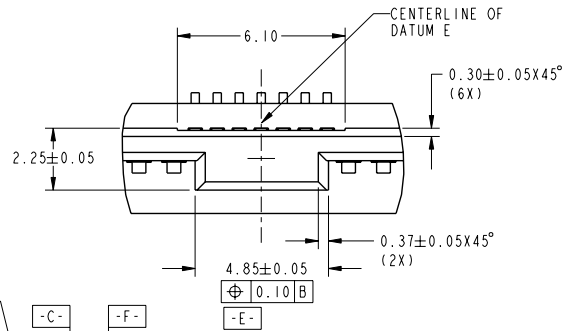
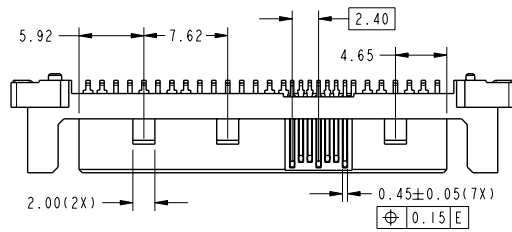
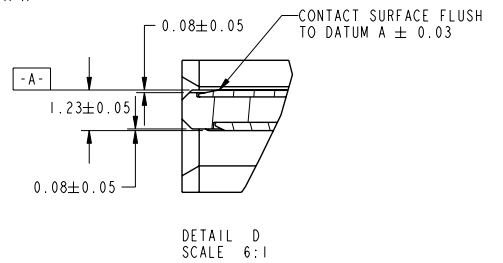
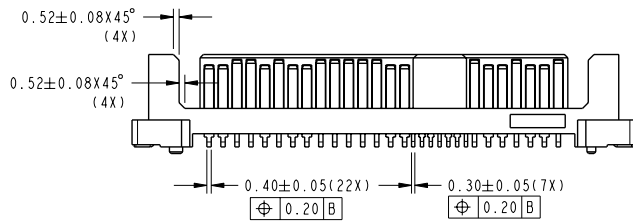

DETAIL D
SCALE 6:1



Copyright FCJ.

	title	SAS PLUG	drawing no	10041724	Rev.	H
	catalog no	VERTICAL SMT ASSY	CUSTOMER	sheet 2 of 3		

REV E - 2004-03-28

PDM: Rev:H STATUS:Released 4 Printed: Dec 01, 2010

PRODUCT NO.	WITH PICK-UP CAP	PACKAGING	PLATING SPEC.
10041724-001LF/-002LF	NO	TRAY	-001LF REFER TO NOTE 2A
10041724-001CLF/-002CLF	YES	TAPE & REEL	-002LF REFER TO NOTE 2B
10041724-001C-TRLF/-002C-TRLF			

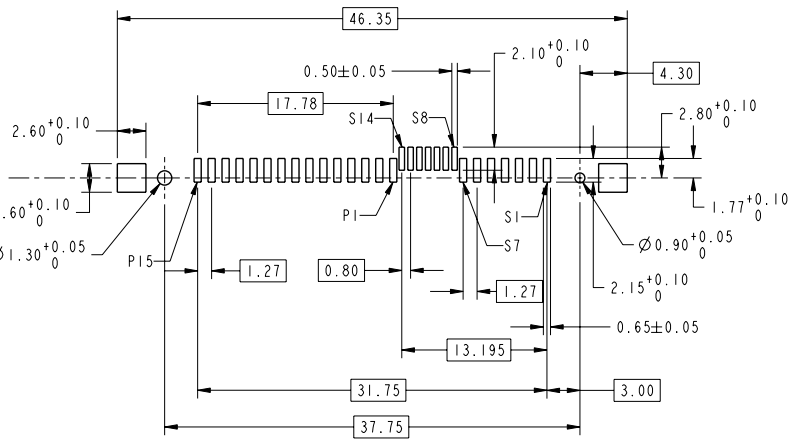
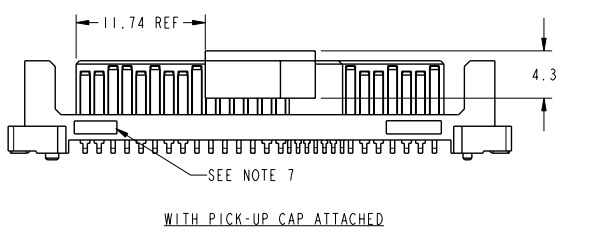
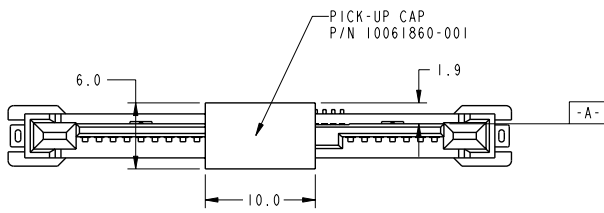

RECOMMENDED SOLDER PAD LAYOUT

- NOTES:
- MATERIAL:
HOUSING & PICK-UP CAP: HIGH TEMPERATURE PLASTIC, BLACK, UL94V-0
CONTACT & HOLD DOWN: COPPER ALLOY
 - FINISH:
CONTACT: 1.27µm MIN. NICKEL UNDERPLATE OVERALL,
2.00µm MIN. 100% MATTE TIN(LEAD FREE) ON SOLDER TAIL,
A) 0.76µm MIN. GOLD ON CONTACT AREA
B) 0.76µm MIN. GXTTM ON CONTACT AREA
HOLD DOWN: 2.54µm MIN. 100% MATTE TIN(LEAD FREE) OVER 1.27µm MIN. NICKEL UNDERPLATE
 - THIS PRODUCT MEETS EUROPEAN UNION DIRECTIVES AND OTHER COUNTRY REGULATIONS AS DESCRIBED IN GS-22-008
 - THE HOUSING WILL WITHSTAND EXPOSURE TO 260°C PEAK TEMPERATURE FOR 10 SECONDS IN A CONVECTION, INFRA-RED OR VAPOR PHASE REFLOW OVEN
 - PART WITH PICK-UP CAP. P/N XXXXXXXX-XXXCLF
 - FOR TAPE & REEL PACKAGING, P/N XXXXXXXX-XXXC-TRLF
 - THE PART SHALL HAVE "FCI" ID AND CAVITY NUMBER SHOWN IN THE APPROXIMATE LOCATION
 - A SYMBOL WILL BE NEXT TO ANY DIMENSION, VIEW OR NOTE WHICH HAS BEEN MODIFIED WITH THE CURRENT DRAWING REVISION

	title	SAS PLUG	drug no	10041724	Rev.	H
	catalog no	VERTICAL SMT ASSY	CUSTOMER	sheet 3 of 3		

Copyright FCI.