

SCA.1, SCA. 2 INTERFACE CONNECTOR

240 SERIES (SCA)

■ FEATURES

- Half pitch connector conformed to SCA system (80 pins).
- Add mating guide and ESD protection to do plug-in safety and reliability (They are newly added on SCA. 2CN).
- Hot-plugging. Ground contacts mate first before other contacts mate when engagement is done (conforms to SCA.2 specification).
- To prevent pin-bending, bellows contacts are used.
- Plug: 2 types are available.
 - 1) The center of a SMT plug mates the center of a PCB.
 - 2) 0.9 mm (0.035 in.) off-set from center



■ SPECIFICATIONS

| Item | Specifications |
|-------------------------------|----------------------------|
| Operating temperature range | -55°C to +105°C |
| Current rating | DC 1 A |
| Voltage rating | AC 240 V |
| Contact resistance | 40 mΩ max. (DC 6 V, 0.1 A) |
| Insulation resistance | 1000 MΩ min. (DC 500 V) |
| Dielectric withstand voltage) | AC 750 V for 1 minute |

■ MATERIALS

| Item | Materials | |
|-----------|---------------------|-------------------|
| Insulator | Polyester (UL94V-0) | |
| Conductor | Copper alloy | |
| Plating | Contact | Gold plating |
| | Terminal | Palladium plating |

240 Series (SCA.2)

PLUG, SMT [0.9 mm (0.035 in.) OFFSET] SCA.2

■ DIMENSIONS

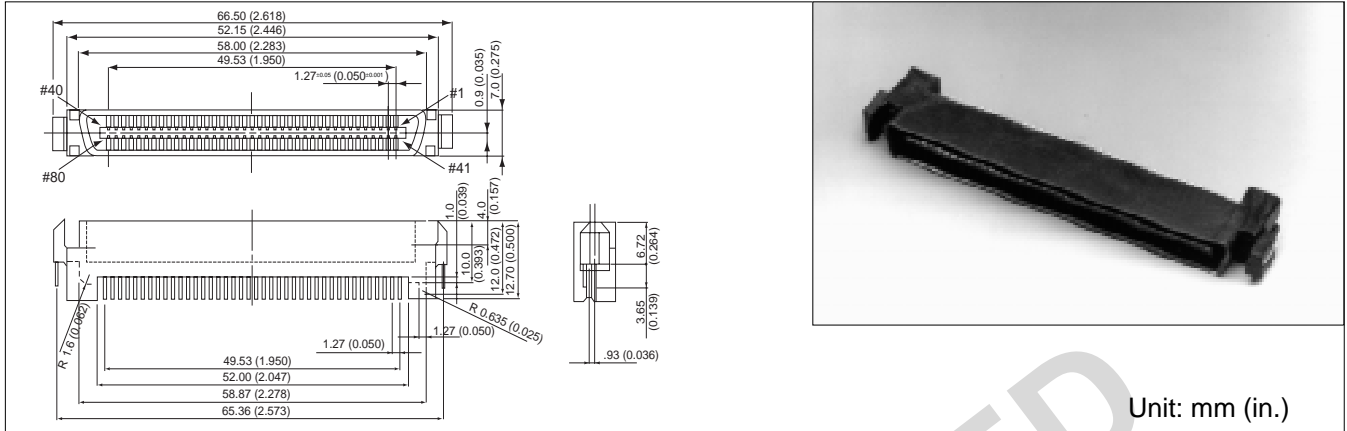

■ PART NUMBER

FCN-248Q080-L/DS

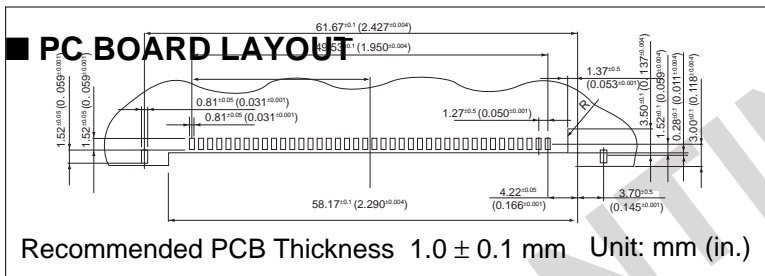

PLUG, SMT (STRADDLE MOUNT) SCA.2

■ DIMENSIONS

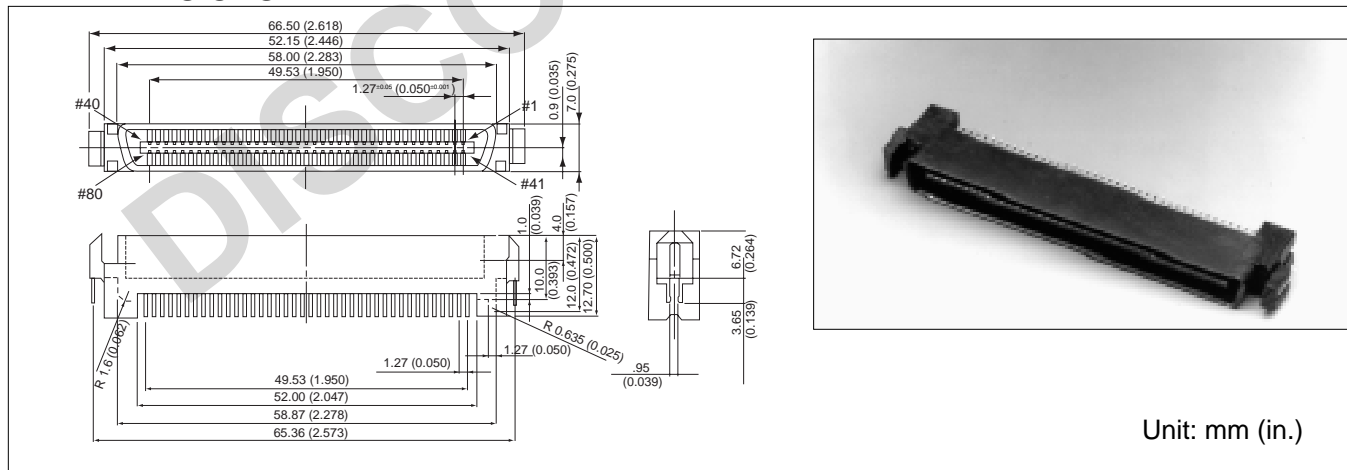

■ PC BOARD LAYOUT

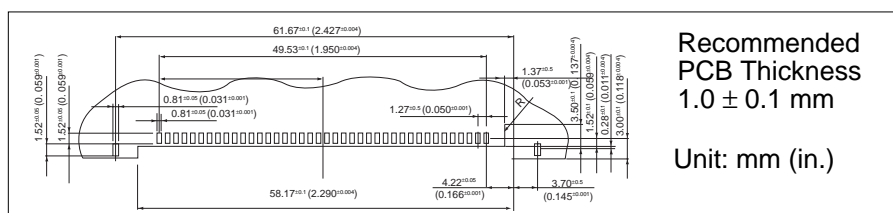

■ PART NUMBER

FCN-248Q080-L/ES

PLUG, SMT (STRADDLE MOUNT) FIBER CHANNEL

SINGLE SIDE SMT SCA.2

■ DIMENSIONS

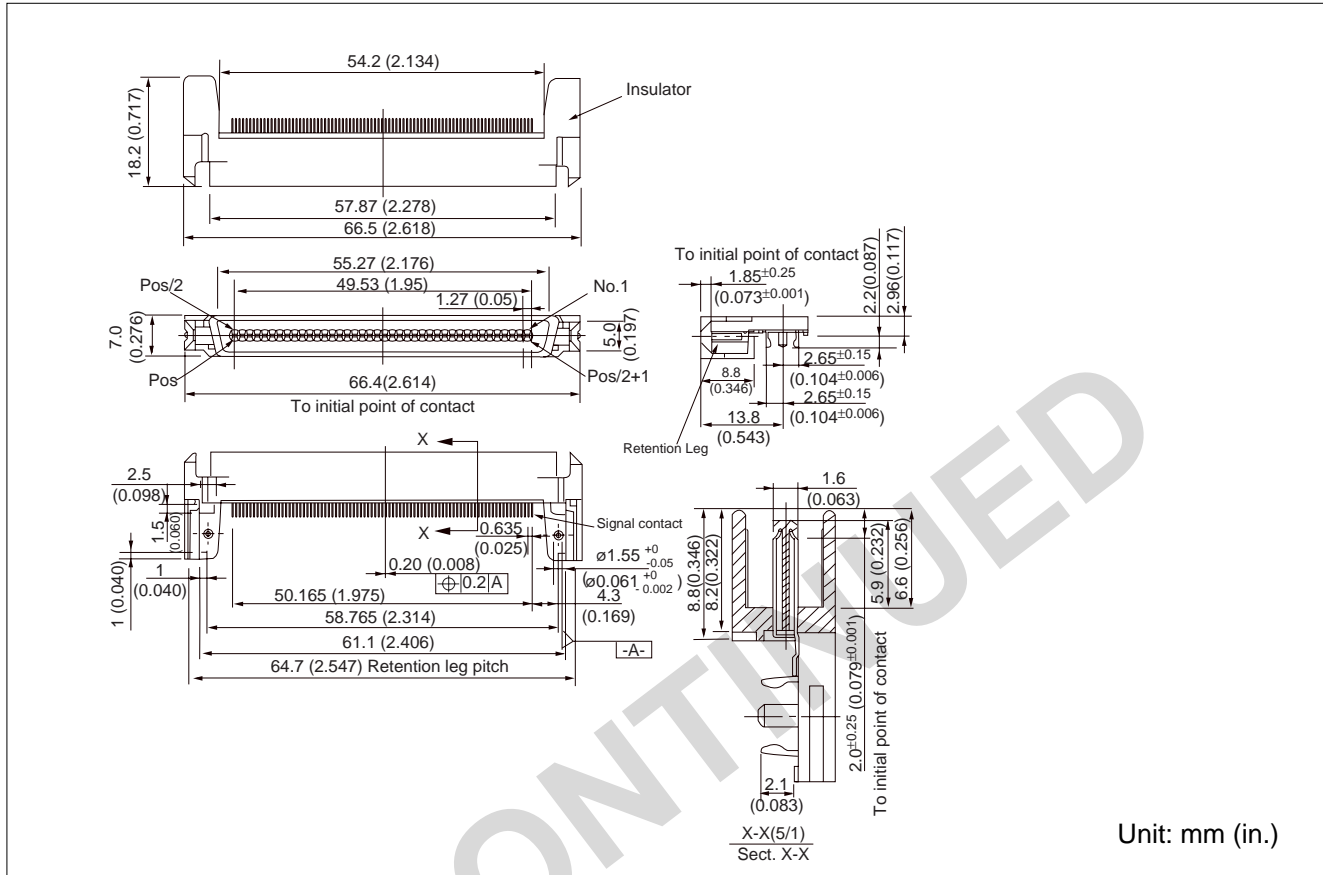

■ PC BOARD LAYOUT

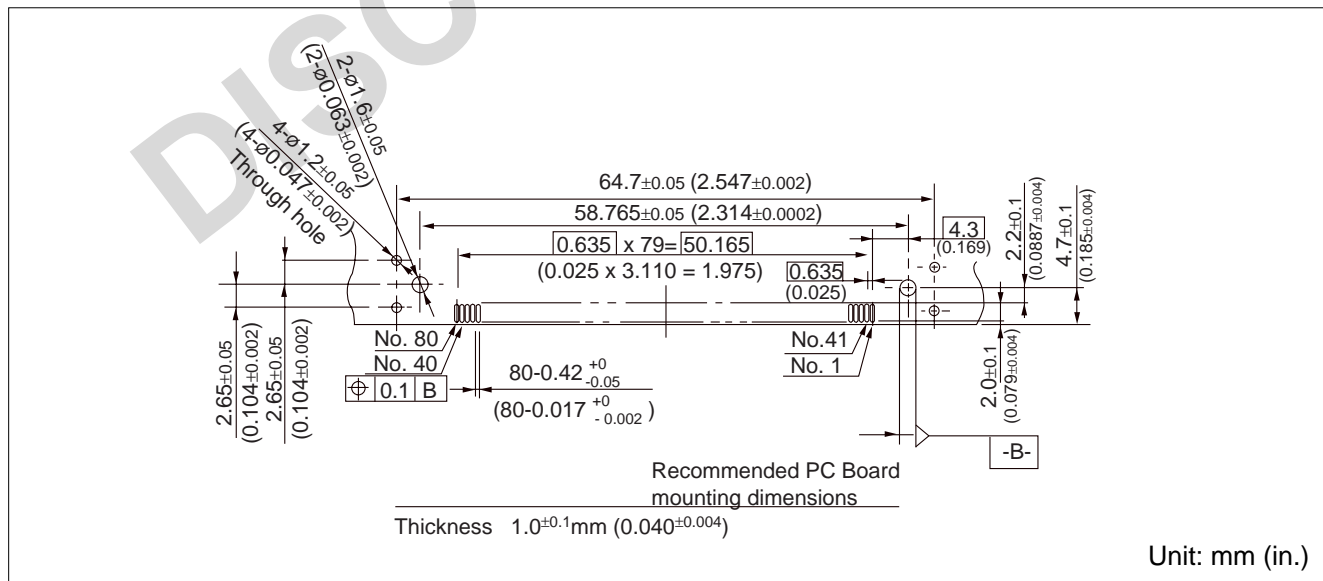

■ PART NUMBER

FCN-248Q080-L/FS

240 Series (SCA.2)

SOCKET, VERTICAL MOUNT

■ DIMENSIONS

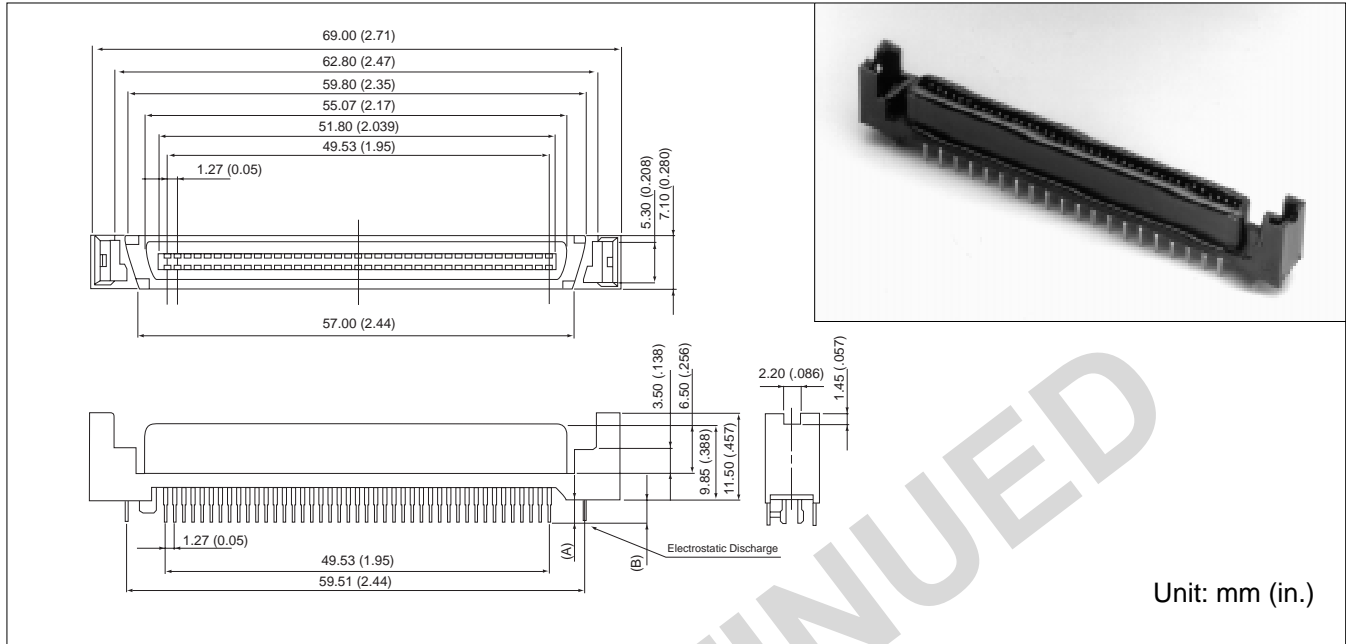

| RECOMMENDED PWB THICKNESS | PART NUMBER | SIGNAL CONTACT POST LENGTH (A) | ESD CONTACT POST LENGTH (B) |
|---------------------------|------------------|--------------------------------|-----------------------------|
| PT : 0.8 mm | FCN-244B080-L/CS | 1.88 (0.074) | 1.88 (0.074) |
| PT : 1.6 mm | FCN-244B080-L/BS | 2.79 (0.110) | 2.70 (0.106) |
| PT : 2.0 mm | FCN-244B080-L/DS | 3.12 (0.123) | 3.12 (0.123) |
| PT : 2.4 mm | FCN-244B080-L/ES | 3.14 (0.124) | 3.45 (0.136) |
| PT : 3.2 mm | FCN-244B080-L/FS | 4.06 (0.160) | 4.27 (0.168) |

■ PC BOARD MOUNTING PATTERN

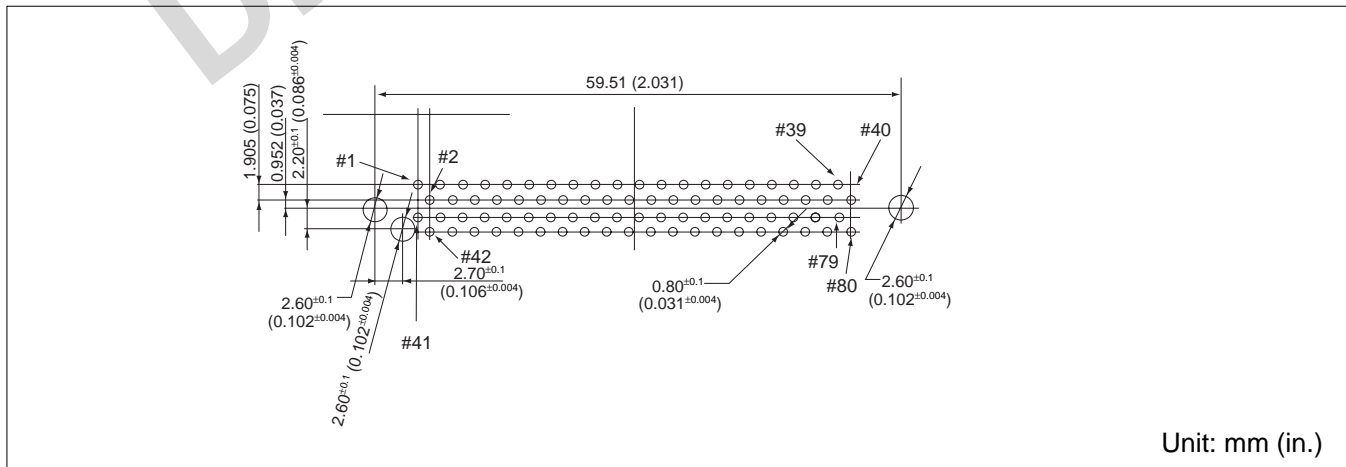

Fujitsu Components International Headquarter Offices

Japan

Fujitsu Component Limited
Gotanda-Chuo Building
3-5, Higashigotanda 2-chome, Shinagawa-ku
Tokyo 141 8630, Japan
Tel: (81-3) 5449-7010
Fax: (81-3) 5449-2626
Email: promothq@fcl.fujitsu.com
Web: www.fcl.fujitsu.com

North and South America

Fujitsu Components America, Inc.
250 E. Caribbean Drive
Sunnyvale, CA 94089 U.S.A.
Tel: (1-408) 745-4900
Fax: (1-408) 745-4970
Email: components@us.fujitsu.com
Web: <http://us.fujitsu.com/components/>

Europe

Fujitsu Components Europe B.V.
Diamantlaan 25
2132 WV Hoofddorp
Netherlands
Tel: (31-23) 5560910
Fax: (31-23) 5560950
Email: info@fceu.fujitsu.com
Web: emea.fujitsu.com/components/

Asia Pacific

Fujitsu Components Asia Ltd.
102E Pasir Panjang Road
#01-01 Citilink Warehouse Complex
Singapore 118529
Tel: (65) 6375-8560
Fax: (65) 6273-3021
Email: [fcal@fcal.fujitsu.com](mailto:fcals@fcal.fujitsu.com)
Web: <http://www.fujitsu.com/sg/services/micro/components/>

©2010 Fujitsu Components America, Inc. All rights reserved. All trademarks or registered trademarks are the property of their respective owners.

Fujitsu Components America or its affiliates do not warrant that the content of datasheet is error free. In a continuing effort to improve our products Fujitsu Components America, Inc. or its affiliates reserve the right to change specifications/datasheets without prior notice.
Rev. September 3, 2010.