

PRODUCT No.	PICK UP CAP	DUST COVER	PACKAGING
10073037-002LF	NO	NO	TRAY
10073037-002CLF	YES	NO	TRAY
10073037-002C-TRLF	YES	NO	TAPE & REEL
10073037-012LF	NO	YES	TRAY
10073037-012CLF	YES	YES	TRAY
10073037-012C-TRLF	YES	YES	TAPE & REEL

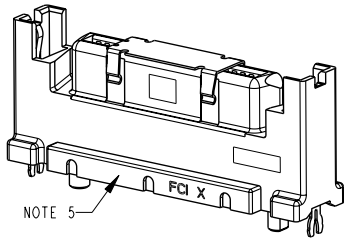

- NOTES:
- MATERIAL :
HOUSING : HIGH TEMPERATURE THERMOPLASTIC
CONTACTS : COPPER ALLOY
ESD CONTACTS : COPPER ALLOY
 - PLATING SPEC:
CONTACTS : 1.27um/50u" MIN NICKEL UNDERPLATE
0.76um/30u" MIN GOLD AT CONTACT AREA
2.54um/100u" MIN TIN AT SOLDER TAIL
ESD CONTACTS : 1.27um/50u" MIN NICKEL UNDERPLATE
2.54um/100u" MIN TIN OVERALL
 - PLATING SPEC:
CONTACTS : 1.27um/50u" MIN NICKEL UNDERPLATE
0.76um/30u" MIN GXT PLATING AT CONTACT AREA
2.54um/100u" MIN TIN AT SOLDER TAIL
ESD CONTACTS : 1.27um/50u" MIN NICKEL UNDERPLATE
2.54um/100u" MIN TIN OVERALL
 - THE HOUSING WILL WITHSTAND EXPOSURE TO 260°C PEAK TEMPERATURE FOR 10 SECONDS IN A CONVECTION, INFRA-RED OR VAPOR PHASE REFLOW OVEN.
 - THIS PRODUCT MEETS EUROPEAN UNION DIRECTIVES AND OTHER COUNTRY REGULATIONS AS DESCRIBED ON GS-22-008.
 - DUST COVER IS OPTIONAL, P/N 10074751-001LF. TO BE ORDER SEPARATELY.
 - A SYMBOL BE NEXT TO ANY DIMENSION, VIEW, OR NOTE WHICH HAS BEEN MODIFIED WITH THE CURRENT DRAWING REVISION.

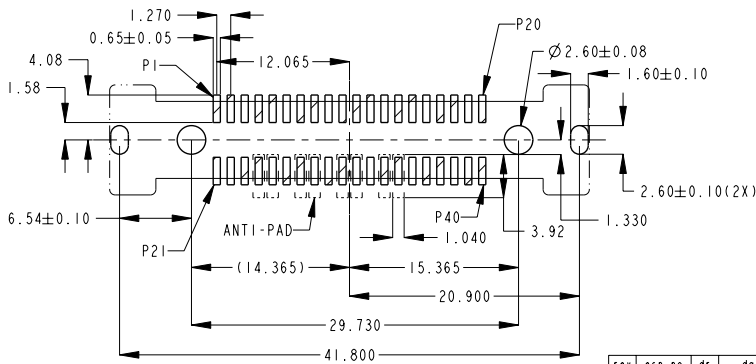

RECOMMENDED PCB LAYOUT
FOR FORK-LOCK HOLD DOWN

rev	ecn no	dr	date
A	S07-0206	TAY	2007-07-14
B	S07-0214	TAY	2007-07-21
C	S07-0356	TAY	2007-10-11
D	S08-0026	TAY	2008-01-29
E	S08-0310	TAYKP	2008-09-26
F	S08-0402	TAYKP	2008-12-05

www.fciconnect.com		surface ASME Y14.5	tolerance std ASME Y14.5	projection MM
		TOLERANCES UNLESS OTHERWISE SPECIFIED		
Dr	KP TAY	2006-08-24	ANGULAR	0.x ±0.35
Eng	KP TAY	2008-12-05	LINEAR	0.xx ±0.25
Chr	KP TAY	2008-12-05	0° ±2°	0.xxx ±0.13
Appr	JOEY NG	2008-12-05	Product family	ECN S08-0402
				Spec ref -
FCI SCA-2 RECEPTACLE			part no	10073037
40 POS EXT. HT. VERTICAL SMT			Rev.	F
catalog no			CUSTOMER	sheet 1 of 2

PDM: Rev:F STATUS:Released Printed: Dec 01, 2010



Copyright FCI.

REV F - 2008-04-17



Copyright FCI.

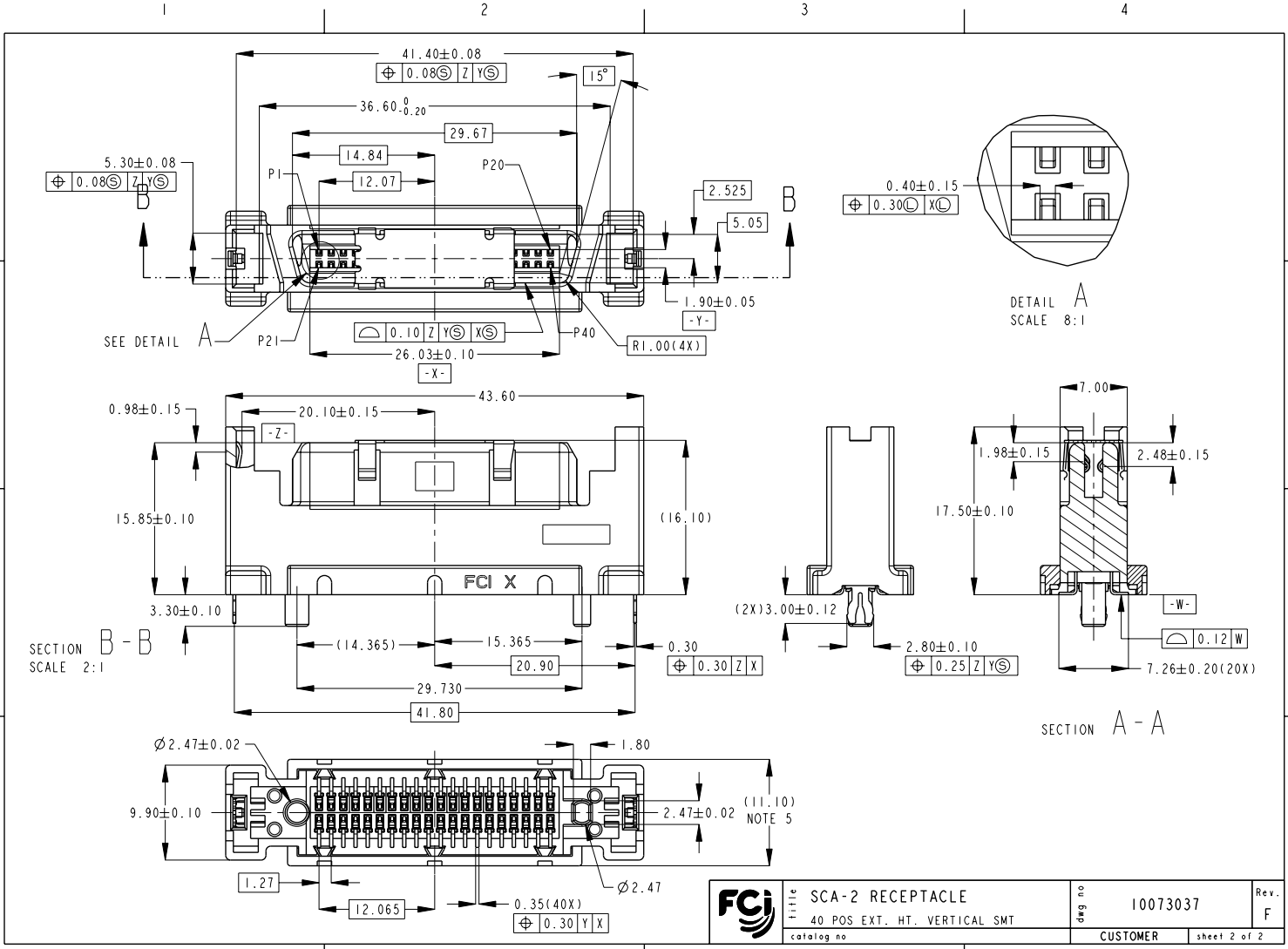

REV F - 2000-04-17

	TITLE	SCA-2 RECEPTACLE	DRG NO	10073037	Rev.	F
	CATALOG NO	40 POS EXT. HT. VERTICAL SMT	CUSTOMER		sheet 2 of 2	

PDM: Rev:F STATUS:Released Printed: Dec 01, 2010