

PRODUCT NUMBER  
58368-11XXXX

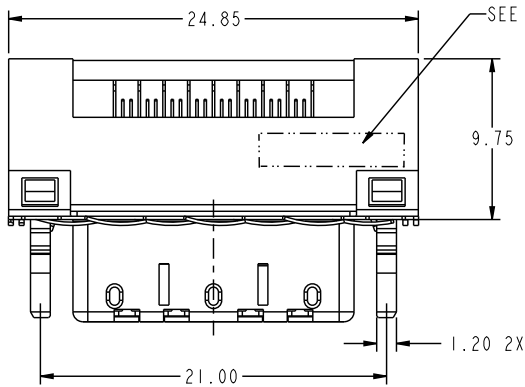

LOCK PLATE SOLD SEPARATELY  
SEE SHEET 8

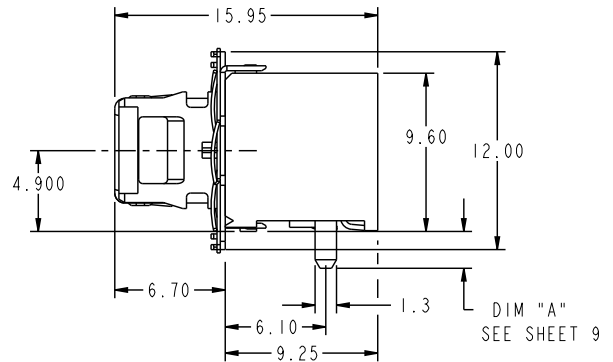
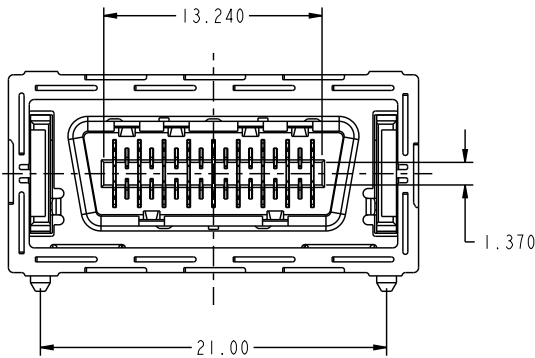
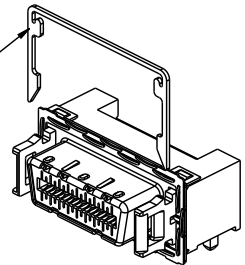

www.fciconnect.com		surface ASME Y14.5	tolerance std ASME Y14.5	projection MM
		TOLERANCES UNLESS OTHERWISE SPECIFIED		
Dr	R. DRAGGOO	2002-01-07	ANGULAR	0.x ±.30
Eng	S. OLSON	2001-09-11	LINEAR	0.xx ±.10
Chr	HIRAN V N	2006-07-26	0° ±2°	0.xxx ±.050
Appr	HIRAN V N	2006-07-26	Product family	InfiniBand
			Spec ref	ECN 109-0115
FCJ			4X R.A. RECEPT. ASS'Y	Rev. L
			w/o MOUNTING TABS	58368
catalog no			CUSTOMER	sheet 1 of 9

rev	ecn no	dr	date
L	109-0115	RPK	2010-04-06
F	V03-0087	GIP	2003-13-14
G	V04-0460	DAI	2004-06-07
H	V05-0063	TAB	2005-02-14
J	105-0258	HVN	2005-11-29
K	106-0123	HVN	2006-07-26

REV F - 2004-04-07

3PDM: Rev:L

STATUS Released

4 Printed: Apr 21, 2010

FCJ  
Copyright FCJ.



Copyright FCI.

1 2 3 4

A

B

C

D

A

B

C

D

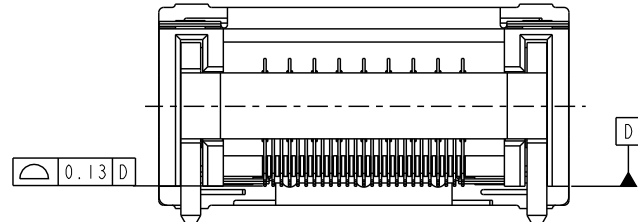

COPLANARITY MEASUREMENT TO BE TAKEN AT BOTTOM MOST POINT OF CONTACT TAILS  
COPLANARITY ZONE IS BELOW DATUM D

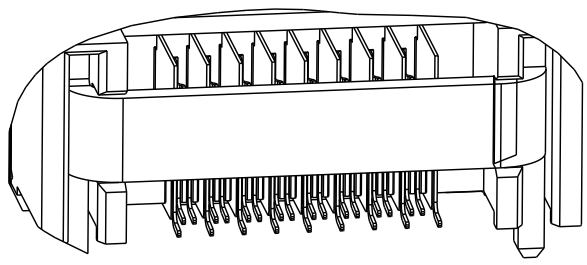

SCALE 4:1

www.fciconnect.com		surface ASME Y14.5 ✓	tolerance std ASME Y14.5 -	projection Ⓢ	MM
TOLERANCES UNLESS OTHERWISE SPECIFIED					
Dr	R. DRAGG00	2002-01-07	ANGULAR	0.x ±.30	size A4 Scale 1:1
Eng	S. OLSON	2001-09-11	LINEAR	0.xx ±.10	
Chr	HIRAN V N	2006-07-26	0* ±*	0.xxx ±.050	ECN 109-0115
Appr	HIRAN V N	2006-07-26	Product family	InfiniBand	Spec ref -
FCJ		4X R.A. RECEPT. ASS'Y		eng no	58368
		w/o MOUNTING TABS		CUSTOMER	sheet 2 of 9
catalog no				Rev.	L

REV F - 2004-04-07

1 2 3 4

3PDM: Rev:L STATUS Released 4 Printed: Apr 21, 2010



Copyright FCJ.

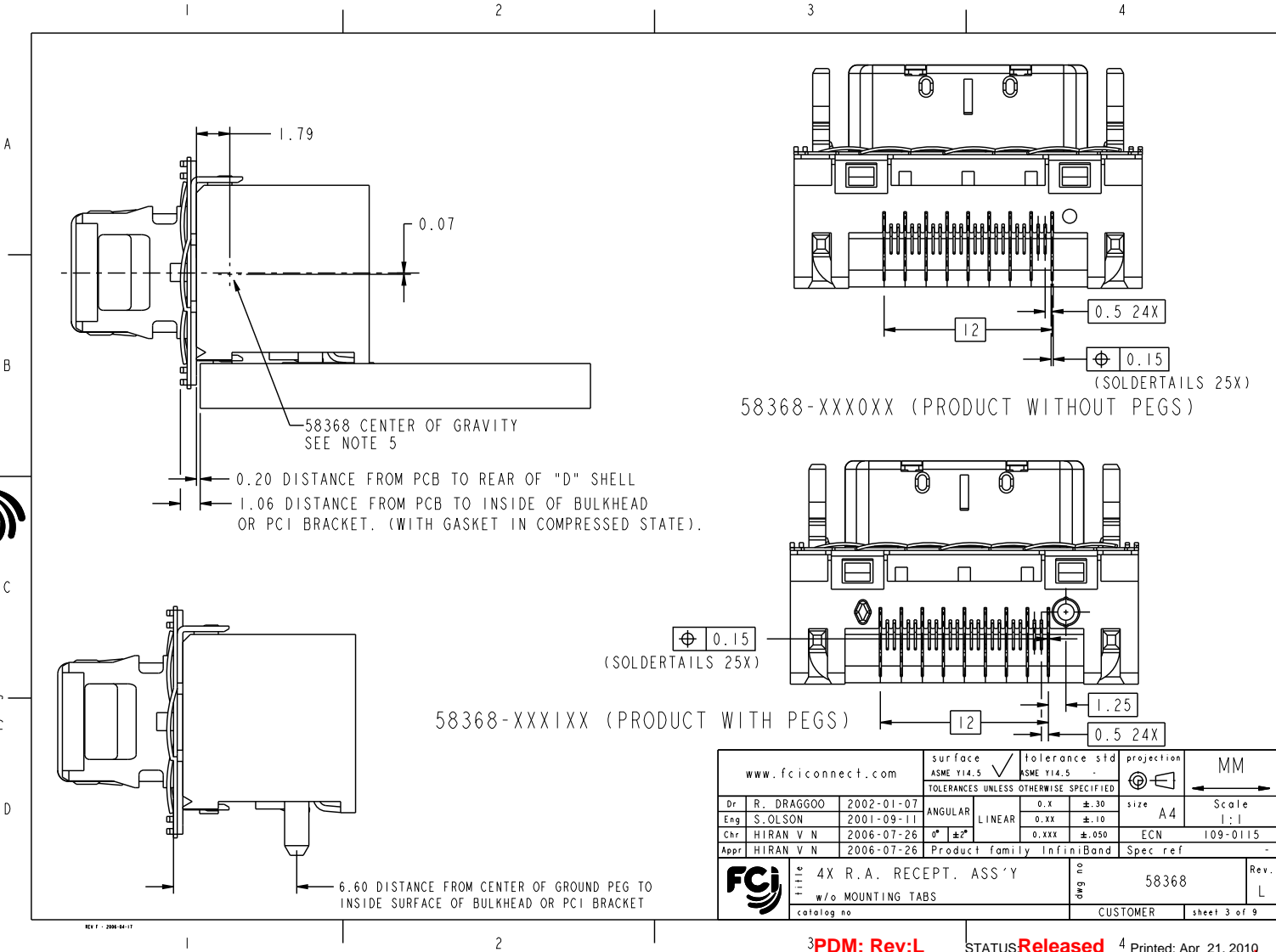

58368-XXXOXX (PRODUCT WITHOUT PEGS)

58368-XXXIXX (PRODUCT WITH PEGS)

www.fciconnect.com		surface ASME Y14.5	tolerance std ASME Y14.5	projection	MM
TOLERANCES UNLESS OTHERWISE SPECIFIED					
Dr	R. DRAGGOO	2002-01-07	ANGULAR	0.x ±.30	size A4 Scale 1:1
Eng	S. OLSON	2001-09-11	LINEAR	0.xx ±.10	ECN 109-0115
Chr	HIRAN V N	2006-07-26	0° ±2°	0.xxx ±.050	Spec ref -
Appr	HIRAN V N	2006-07-26	Product family	InfiniBand	
FCJ		4X R.A. RECEPT. ASS'Y		58368	Rev. L
w/o MOUNTING TABS		catalog no		CUSTOMER	sheet 3 of 9



Copyright FCJ.

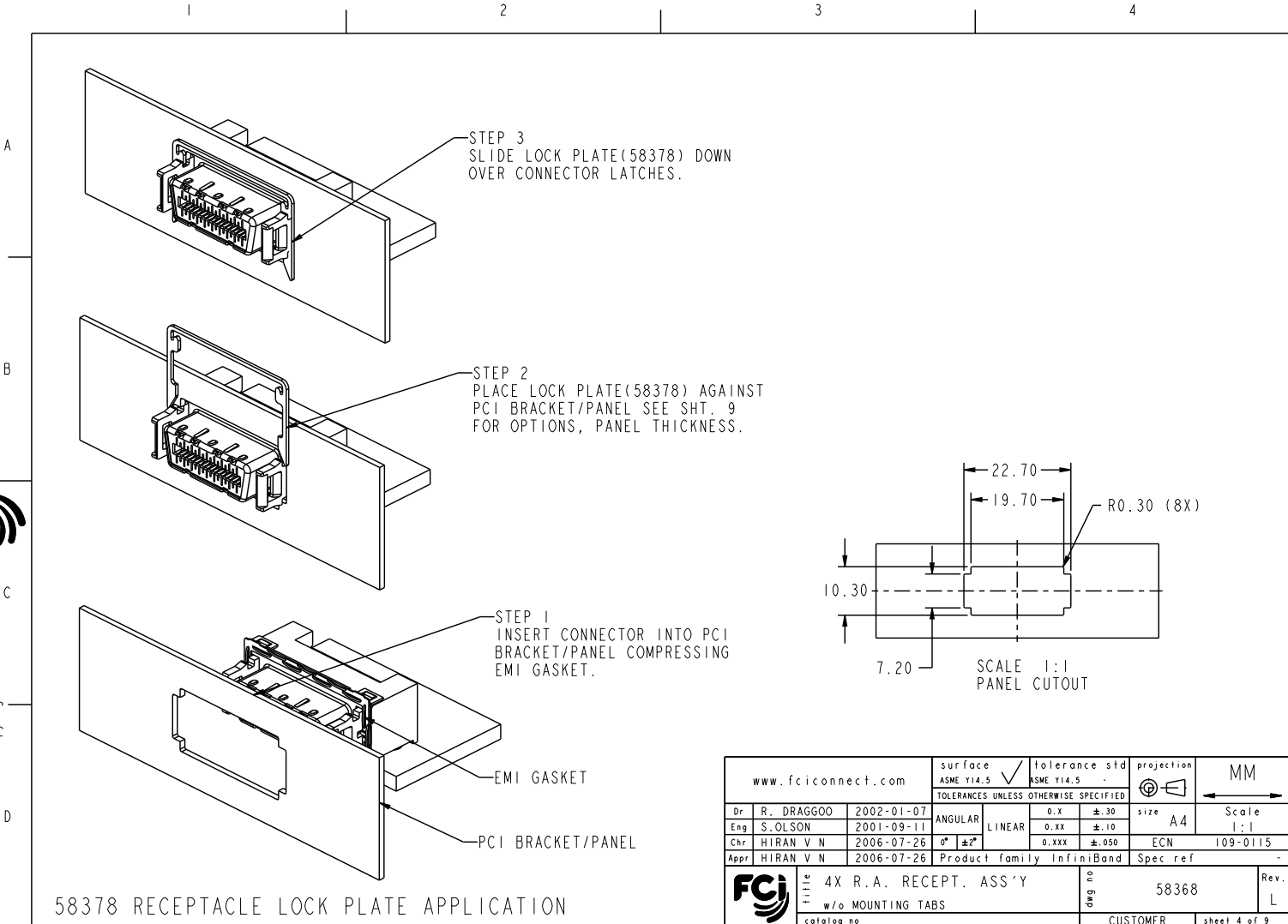

### 58378 RECEPTACLE LOCK PLATE APPLICATION

REV F - 2004-04-07

www.fciconnect.com		surface ASME Y14.5 ✓	tolerance std ASME Y14.5	projection Ⓢ	MM
TOLERANCES UNLESS OTHERWISE SPECIFIED					
Dr	R. DRAGGOO	2002-01-07	ANGULAR	LINEAR	size A4
Eng	S. OLSON	2001-09-11	0.x	±.30	Scale 1:1
Chr	HIRAN V N	2006-07-26	0.xx	±.10	ECN 109-0115
Appr	HIRAN V N	2006-07-26	0.xxx	±.050	Spec ref -
FCJ		4X R.A. RECEPT. ASS'Y		eng no	58368
w/o MOUNTING TABS		Rev. L		CUSTOMER	sheet 4 of 9
catalog no					



Copyright FCJ.

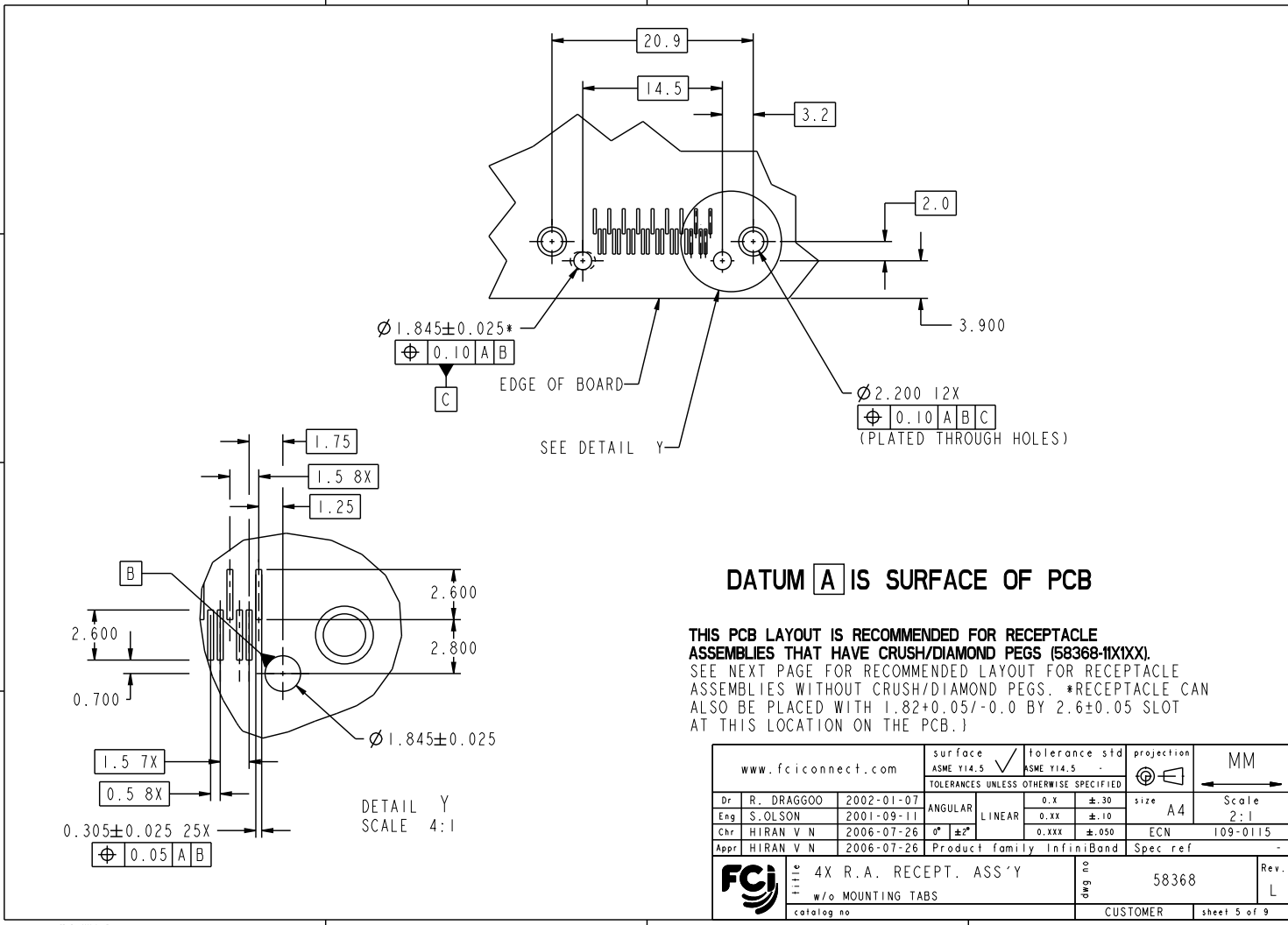

DATUM A IS SURFACE OF PCB

**THIS PCB LAYOUT IS RECOMMENDED FOR RECEPTACLE ASSEMBLIES THAT HAVE CRUSH/DIAMOND PEGS (58368-11X1XX).**  
 SEE NEXT PAGE FOR RECOMMENDED LAYOUT FOR RECEPTACLE ASSEMBLIES WITHOUT CRUSH/DIAMOND PEGS. \*RECEPTACLE CAN ALSO BE PLACED WITH 1.82±0.05/-0.0 BY 2.6±0.05 SLOT AT THIS LOCATION ON THE PCB.)

www.fciconnect.com		surface	ASME Y14.5	tolerance std	ASME Y14.5	projection	MM
		TOLERANCES UNLESS OTHERWISE SPECIFIED					
Dr	R. DRAGGOO	2002-01-07	ANGULAR	LINEAR	0.x	±.30	size A4
Eng	S. OLSON	2001-09-11	0°	±*	0.xx	±.10	Scale 2:1
Chr	HIRAN V N	2006-07-26	Product family InfiniBand		0.xxx	±.050	ECN 109-0115
Appr	HIRAN V N	2006-07-26	Spec ref				-
FCJ		4X R.A. RECEPT. ASS'Y		58368		Rev. L	
w/o MOUNTING TABS		CUSTOMER		sheet 5 of 9			



Copyright FCI.

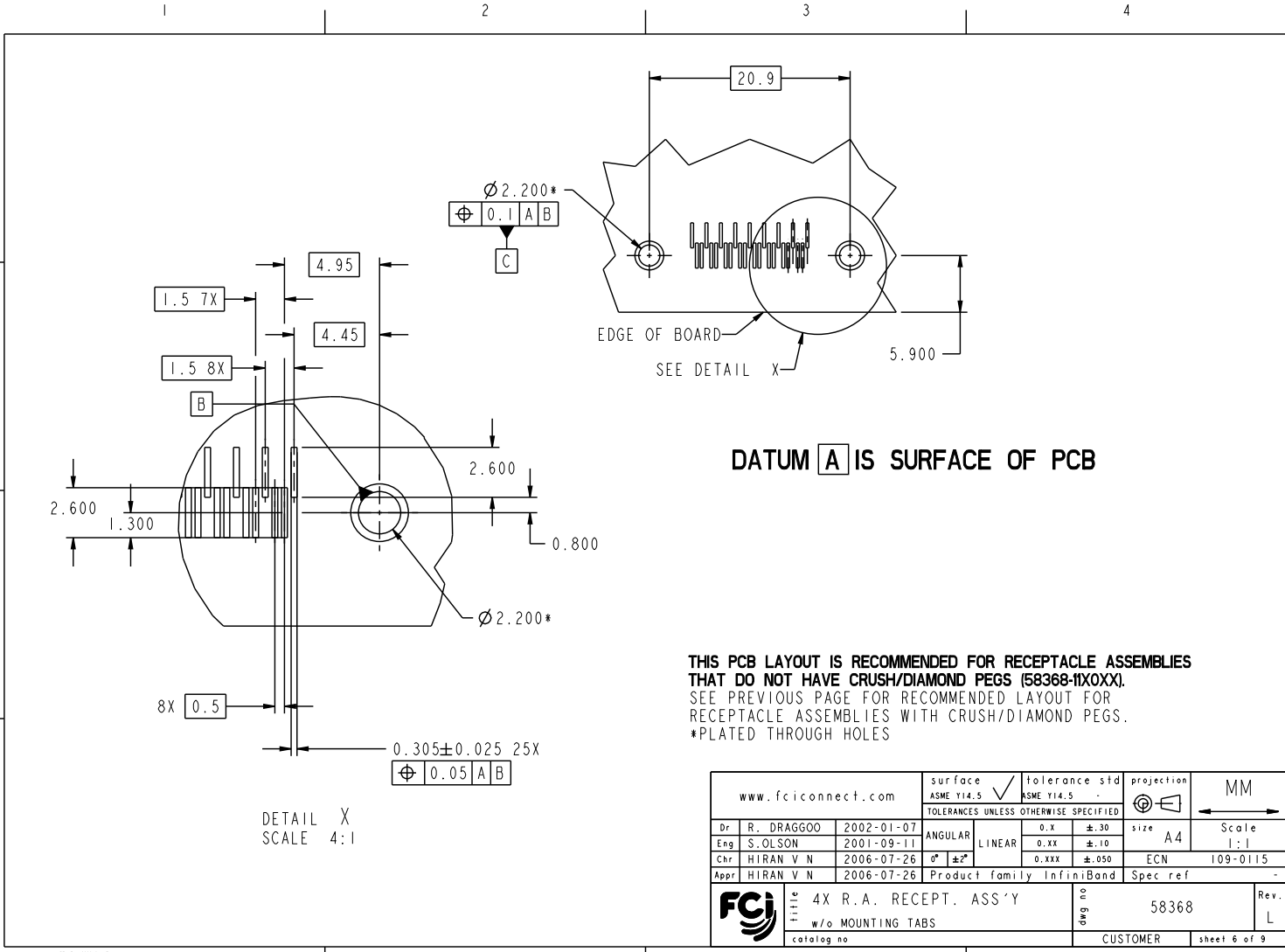

**THIS PCB LAYOUT IS RECOMMENDED FOR RECEPTACLE ASSEMBLIES THAT DO NOT HAVE CRUSH/DIAMOND PEGS (58368-11X0XX).**  
 SEE PREVIOUS PAGE FOR RECOMMENDED LAYOUT FOR RECEPTACLE ASSEMBLIES WITH CRUSH/DIAMOND PEGS.  
 \*PLATED THROUGH HOLES

www.fciconnect.com		surface ASME Y14.5 ✓	tolerance std ASME Y14.5 -	projection ⊕	MM
TOLERANCES UNLESS OTHERWISE SPECIFIED					
Dr	R. DRAGGOO	2002-01-07	ANGULAR	0.x ±.30	size A4 Scale 1:1
Eng	S. OLSON	2001-09-11	LINEAR	0.xx ±.10	
Chr	HIRAN V N	2006-07-26	0* ±*	0.xxx ±.050	ECN 109-0115
Appr	HIRAN V N	2006-07-26	Product family	InfiniBand	Spec ref -
FCI		4X R.A. RECEPT. ASS'Y		eng no	58368
w/o MOUNTING TABS		CUSTOMER		Rev.	L
catalog no		sheet 6 of 9			



Copyright FCJ.

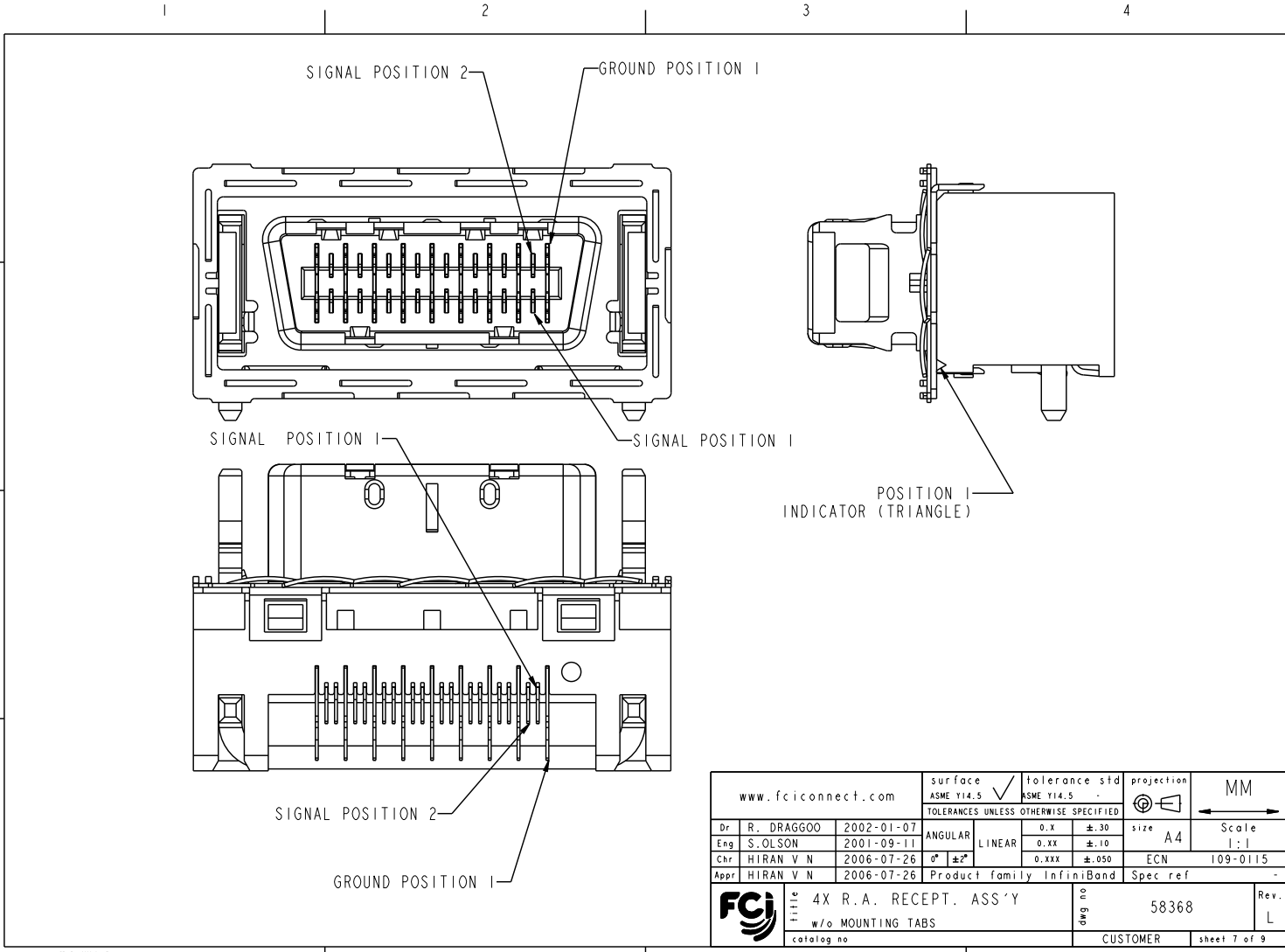

www.fciconnect.com		surface ASME Y14.5 ✓	tolerance std ASME Y14.5	projection Ⓢ	MM
TOLERANCES UNLESS OTHERWISE SPECIFIED					
Dr	R. DRAGG00	2002-01-07	ANGULAR	LINEAR	size A4
Eng	S. OLSON	2001-09-11	0.x	±.30	Scale 1:1
Chr	HIRAN V N	2006-07-26	0°. ±*	0.xxx ±.050	ECN 109-0115
Appr	HIRAN V N	2006-07-26	Product family InfiniBand		Spec ref -
FCJ		4X R.A. RECEPT. ASS'Y		eng no	58368
		w/o MOUNTING TABS		CUSTOMER	sheet 7 of 9
catalog no					

REV F - 2004-04-07

**3PDM: Rev:L** STATUS **Released** <sup>4</sup> Printed: Apr 21, 2010

LOCK PLATE PART NUMBER	DIM "B"	SIZE	USED WITH		QTY PER BAG
			ASSEMBLY	PANEL THICKNESS	
58378-001	0.50	4X	58368	1.00±0.03mm/0.040±.001"	100
58378-011	0.30	4X	58368	1.20±0.03mm/0.047±.001"	100
58378-021	0.60	4X	58368	0.91±0.03mm/0.0359±.001" (20 GAGE PCI BRACKET)	100

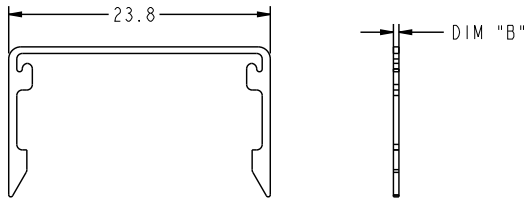

THESE PANEL LOCK PLATES ARE TO BE ORDERED SEPARATELY

PART NUMBER	KEYING POSITIONS					
	POSITION 1	POSITION 2	POSITION 3	POSITION 4	POSITION 5	POSITION 6
58368-11XXX2		X				X

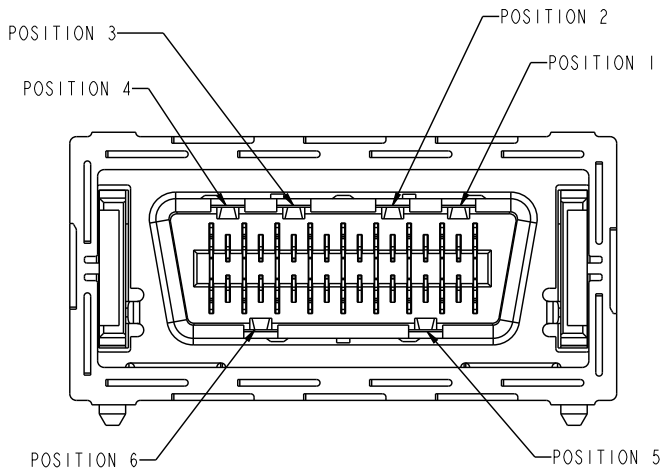

www.fciconnect.com		surface ASME Y14.5 ✓	tolerance std ASME Y14.5	projection MM		
		TOLERANCES UNLESS OTHERWISE SPECIFIED		size A4	Scale 1:1	
Dr	R. DRAGGOO	2002-01-07	ANGULAR	0.X	±.30	
Eng	S. OLSON	2001-09-11	LINEAR	0.XX	±.10	
Chr	HIRAN V N	2006-07-26	0° ±*	0.XXX	±.050	ECN 109-0115
Appr	HIRAN V N	2006-07-26	Product family InfiniBand		Spec ref -	
FCJ		4X R.A. RECEPT. ASS'Y w/o MOUNTING TABS		Eng no	58368	Rev. L
catalog no		CUSTOMER		sheet 8 of 9		

3PDM: Rev:L STATUS Released 4 Printed: Apr 21, 2010

REV F - 2004-04-07



Copyright FCJ.



58368-1XXXXXX

- SOLDERTAIL PLATING  
BLANK-TIN/LEAD  
LF-LEAD FREE (SEE NOTE 2)
- KEYING OPTIONS, SEE SHEET 8  
0-NONE  
2-CUSTOM
- PACKAGING  
1-TAPE & REEL  
2-TRAY
- PEGS  
0-NONE  
1-CRUSH/DIAMOND PEGS
- PCB THICKNESS  
1-1.6mm  
2-2.4mm  
3-4.0mm
- EMI GASKET  
0-WITHOUT GASKET  
1-WITH GASKET
- INTERFACE PLATING  
1-Au over Ni

NOTES: )

- ① HOUSING MATERIAL: UL94 V-0 LCP RESIN.  
SIGNAL PIN MATERIAL: COPPER ALLOY.  
GROUND CONTACT MATERIAL: COPPER ALLOY.
- ② PLATING: LEAD FREE SOLDER TAILS 2μm (80μin) MIN MATTE TIN  
OVER 1.27μm (50μin) MIN NICKEL UNDERPLATE.
- ③ P/N AND DATE CODE TO APPEAR  
ON THIS SURFACE.
4. PRODUCT SPECIFICATION GS-12-209.
5. CONNECTOR WEIGHT = 6.38 grams
6. APPLICATION SPECIFICATION: GS-20-025
7. PACKAGING SPECIFICATION GS-14-794. PACKAGING OF LEAD FREE  
PRODUCTS MEETS LABELING AND PACKAGING SPECIFICATION GS-14-920.
8. ALL DIMENSIONS ON PCB'S ARE BASIC UNLESS OTHERWISE SPECIFIED.
9. ALL HOLE DIAMETERS ON PCB'S ARE FINISHED HOLE SIZE
- ⑩ AREA ON TOP OF CONNECTOR IS FLAT & SMOOTH AND  
CAN BE USED FOR VACUUM PICK & PLACE.
11. MATES WITH EYEMAX® PLUG 58443 (WITHOUT PCB),  
58638 (WITH UNEQUALIZED PCB) OR 10026692 (WITH EQUALIZED PCB).
12. LEAD FREE PRODUCTS MEET EUROPEAN UNION DIRECTIVES AND  
OTHER COUNTRY REGULATIONS AS DESCRIBED IN GS-22-008.
13. THE HOUSING WILL WITHSTAND EXPOSURE TO 260°C PEAK TEMPERATURE  
FOR 15 SECONDS IN A CONVECTION, INFRARED OR VAPOR PHASE REFLOW  
OVEN.

PRODUCT NUMBER	BOARD THICKNESS	DIM A
58368-111XXX	1.6mm	2.3
58368-112XXX	2.4mm	3.1
58368-113XXX	4.0mm	4.7

www.fciconnect.com		surface ASME Y14.5 ✓	tolerance std ASME Y14.5	projection Ⓢ	MM
TOLERANCES UNLESS OTHERWISE SPECIFIED					
Dr	R. DRAGGOO	2002-01-07	ANGULAR	0.x ±.30	size A4 Scale 1:1
Eng	S. OLSON	2001-09-11	LINEAR	0.xx ±.10	
Chr	HIRAN V N	2006-07-26	0* ±*	0.xxx ±.050	ECN 109-0115
Appr	HIRAN V N	2006-07-26	Product family	InfiniBand	Spec ref -
FCJ			4X R.A. RECEPT. ASS'Y		Rev. L
			w/o MOUNTING TABS		58368
catalog no			CUSTOMER		sheet 9 of 9



Copyright FCI.

REV F - 2004-04-07