

FCI CONFIDENTIAL

This document is the property of and embodies CONFIDENTIAL and PROPRIETARY information of FCI. No part of the information shown on this drawing is to be disclosed, copied, or otherwise used without the written consent of FCI. Copyright © FCI.

PRODUCT NO	METAL CLIP	PLATING	PICK-UP CAP	PACKAGING	REMARKS	PRODUCT NO	PLATING
10031567-001LF	2 PCS	NOTE 2	NO	TRAY	⑧	10031567-401LF	NOTE 11
10031567-001CLF			YES		④,⑧	10031567-401CLF	
10031567-001C-TRLF			YES		④,⑥,⑧	10031567-401C-TRLF	

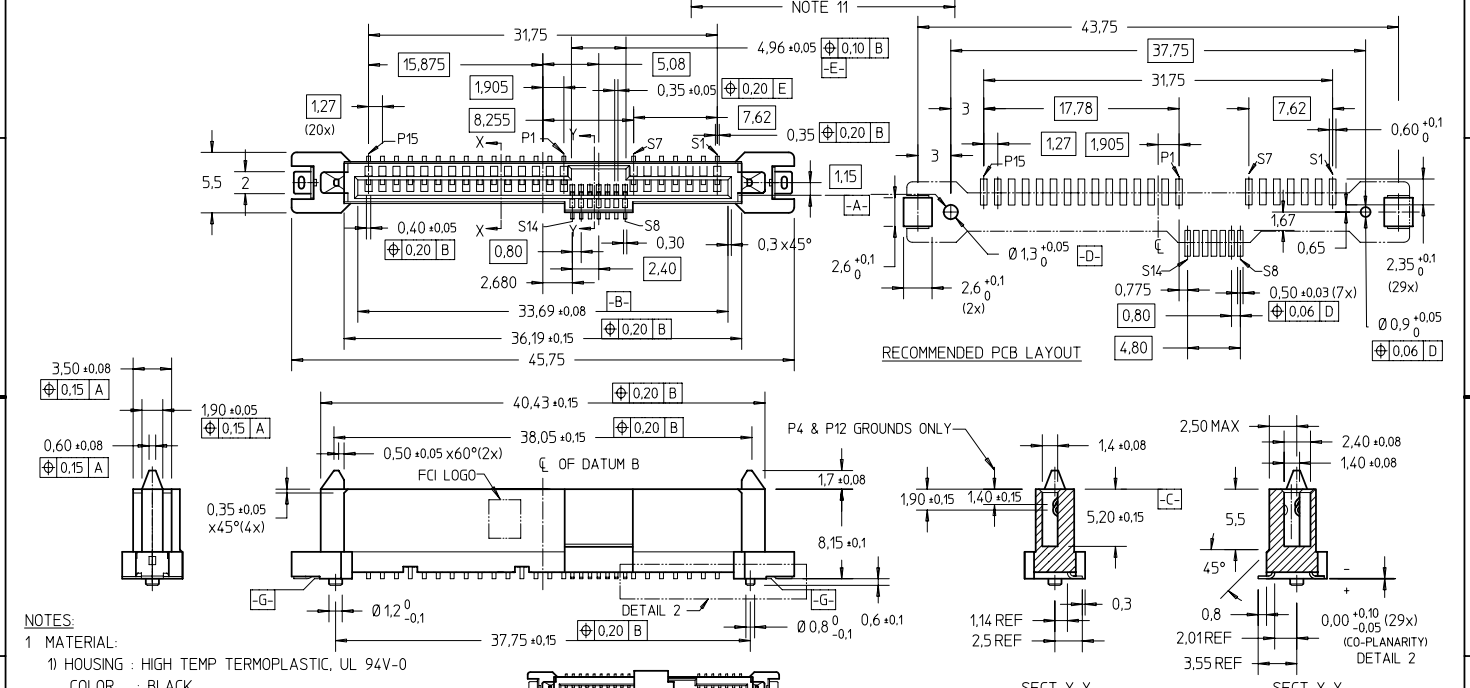

- NOTES:**
- MATERIAL:
 - HOUSING : HIGH TEMP TERMOPLASTIC, UL 94V-0
COLOR : BLACK
 - TERMINAL : COPPER ALLOY
 - HOLD DOWN : COPPER ALLOY
 - FINISH :
 - TERMINAL : 30u" Au PLATING (CONTACT POINT)
OVER 50u" NICKEL
 - SOLDER TAIL : 100u" min Sn OVER 50u" NICKEL
 - HOLD DOWN : 100u" min Sn OVER 50u" NICKEL
 - PER SFF REV 1.1, EXCEPT 0.8mm PITCH BUMP AREA.
 - PART WITH PICK-UP CAP, P/N XXXXXXXX-XXX LF

mat'l code	surface	tolerance	projection	product family
ISO 1302	ISO 406 ISO 1101	ISO 1101	mm	SAS
tr ecn no dr date	tolerances unless otherwise specified	angles	linear	title
F S05-0292 GLL 2005-10-12	± 2°	± 0.20	scale 2:1	SAS RECEPTACLE VERTICAL SMT TYPE ASSY
G S06-0281 GLL 2006-08-28				dwg no sheet 1 of 3 size
H S07-0045 GLL 2007-02-09				10031567 A4
J S09-0052 GLL 2009-02-19	dr	QL L00 2004-02-27		type CUSTOMER Drawing
K S09-0283 GLL 2009-09-09	engr	QL L00 2004-02-27		
L S09-0403 GLL 2009-12-10	chr	QL L00 2009-12-10		
	appd	JOEY NS 2009-12-10		
sheet revision L L L				
index sheet 1 2 3				

FCI CONFIDENTIAL

FCI
FCIconnect.com
This document is the property of and embodies CONFIDENTIAL and PROPRIETARY information of FCI. No part of the information shown here may be reproduced, stored in a retrieval system, or transmitted in any way or by any means, without the written consent of FCI.
Copyright FCI.

PRODUCT NO	METAL CLIP	PLATING	PICK-UP CAP	PACKAGING	REMARKS	PRODUCT NO	PLATING
10031567-002LF	1 PC	NOTE 2	NO	TRAY	⑧	10031567-402LF	NOTE 11
10031567-002CLF			YES		④,⑧	10031567-402CLF	
10031567-002C-TRLF			YES		④,⑥,⑧	10031567-402C-TRLF	

NOTE 11

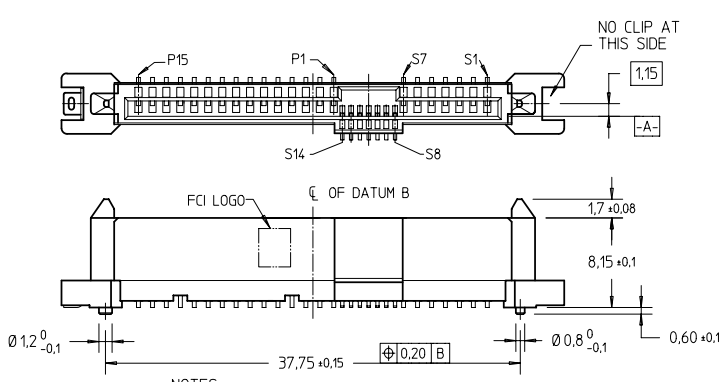

NOTES:
ALL OTHER DIMENSIONS, REFER TO SHEET 1.

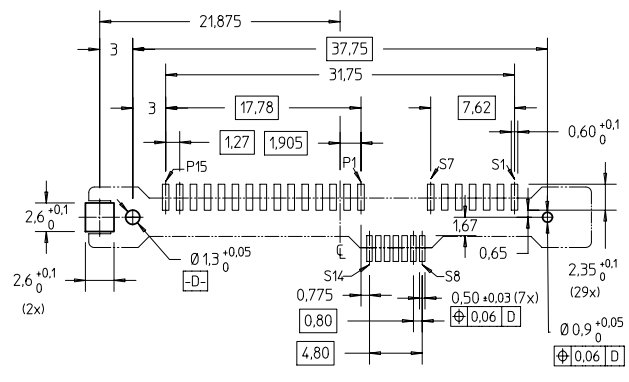

RECOMMENDED PCB LAYOUT

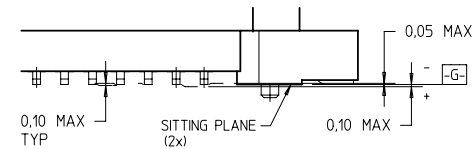

DETAIL 2
S : 3/1

- NOTES:
- ⑤ THE STD PACKAGING IS IN TRAY UNLESS OTHERWISE SPECIFIED.
 - ⑥ PART NUMBER WITH SUFFIX "-TR" MEANS FOR TAPE & REEL PACKAGING (E.G. P/N XXXXXXXX-XXC-TRLF).
 - 7 THE HOUSING WILL WITHSTAND EXPOSURE TO 260°C PEAK TEMPERATURE FOR 10 SECONDS IN A CONVECTION, INFRA-RED OR VAPOR PHASE REFLOW OVEN.
 - ⑧ THIS PRODUCT MEETS EUROPEAN UNION DIRECTIVES AND OTHER COUNTRY REGULATIONS AS DESCRIBED IN GS-22-008.
 - ⑨ PART NUMBERS ENDING IN "LF" MEANS FOR NOTE 8 LEAD FREE IDENTIFICATION
 - ⊖ XXXXXXXX-XXXLF IS EQUIVALENT TO PREVIOUS P/N XXXXXXXX-XXX
 - ⊖ XXXXXXXX-XXXCLF IS EQUIVALENT TO P/N XXXXXXXX-XXC
 - ⊖ XXXXXXXX-XXC-TRLF IS EQUIVALENT TO P/N XXXXXXXX-XXC-TR
 - ⑩ A Δ SYMBOL WILL BE NEXT TO ANY DIMENSION, VIEW, OR NOTE WHICH HAS BEEN MODIFIED WITH THE CURRENT DRAWING REVISION.
 - ⑪ FINISH :
 - 1) TERMINAL : 15u" GXT PLATING (CONTACT POINT) OVER 50u" NICKEL
 - 2) SOLDER TAIL : 100u" min Sn OVER 50u" NICKEL
 - 3) HOLD DOWN : 100u" min Sn OVER 50u" NICKEL

mat'l. code		surface	tolerance	projection	product family	
ISO 1302		ISO 406	ISO 1101	product family	SAS	
tr	ecn no	dr	date	title		
tolerances unless otherwise specified				SAS RECEPTACLE		
angles				VERTICAL SMT TYPE ASSY		
linear				dwg no		
± 2°				10031567		
dr				sheet 2 of 3 size		
engr				A4		
chr				type		
appd				CUSTOMER Drawing		
sheet index		revision	sheet			
1		1	1			

FCI CONFIDENTIAL



This document is the property of and embodies CONFIDENTIAL and PROPRIETARY information of FCI. No part of the information herein shall be disclosed, in any way or disclosed to others without the written consent of FCI. Copyright FCI.



PRODUCT NO	METAL CLIP	PLATING	PICK-UP CAP	PACKAGING	REMARKS
10031567-404C-TRLF	1 PC	NOTE 11	YES	CUSTOM-MADE TAPE & REEL	④.⑥.⑧

mat'l. code		surface	tolerance	projection	product family
ISO 1302		ISO 406 ISO 1101			SAS
ltr	ecm no	dr	date	title	
L				SAS RECEPTACLE VERTICAL SMT TYPE ASSY	
			angles	linear	mm
			± 2°	= +0.20	← →
			dr	Q. L00	2009-12-10
			engr	Q. L00	2009-12-10
			chr	Q. L00	2009-12-10
			appd	JOEY NS	2009-12-10
sheet	revision				
index	sheet	1			