

NUMBER C-440247
 METRIC
 3RD ANGLE PROJECTION

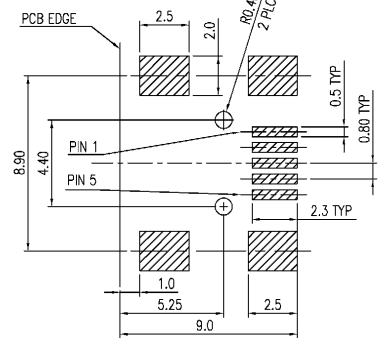

RECOMMENDED PCB LAYOUT (MOUNTING SIDE)
 THICKNESS 1.57mm

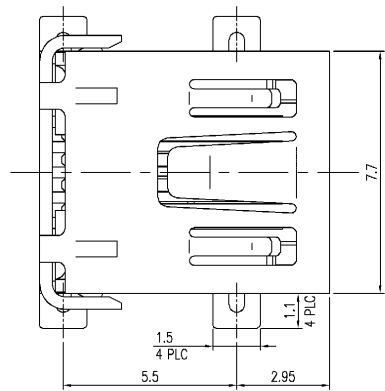
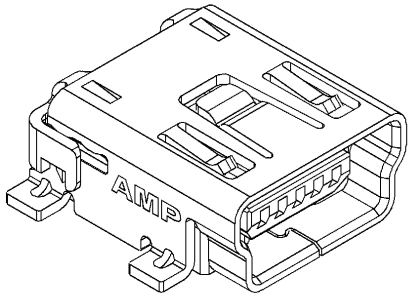
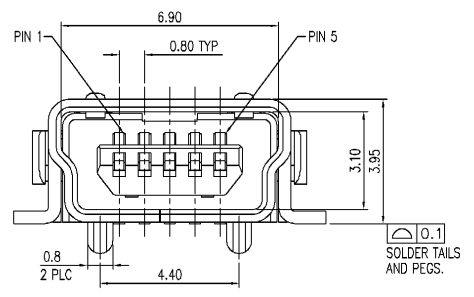
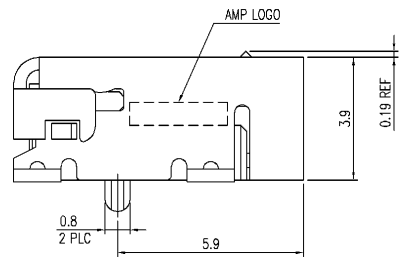
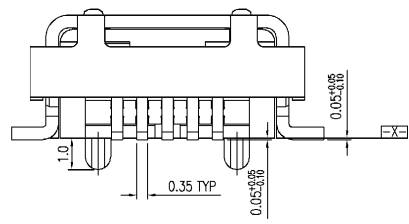

NOTE:
 1. MATERIAL:
 HOUSING: HIGH TEMPERATURE THERMOPLASTIC UL 94V-0, COLOR: BLACK.
 CONTACT: PHOSPHOR BRONZE.
 SHELL: PHOSPHOR BRONZE.
 2. FINISH:
 CONTACT: 30u" MIN. GOLD PLATED IN CONTACT AREA, 100u" MIN. TIN-LEAD
 TIN ON SOLDER TAILS, 50u" MIN. NICKEL UNDERPLATED ALL OVER.
 SHELL: 100u" MIN. HALF-BRIGHT TIN OVER 100u" MIN. CU UNDERPLATED.

W/	W/O	TAPE REEL	W/	440247-4
W/O	W/	TAPE REEL	W/	440247-3
W/O	W/O	TAPE REEL	W/	440247-2
W/O	N/A	TRAY	W/	440247-1
MYLAR	LONG CARRIER & COVER TAPE	PACKAGE	POST	PART NUMBER

DIMENSION :	DWN	O. HU	tyco	TYCO HOLDINGS (BERMUDA)
0 PLC ±0.38	CHK	27-JUN-2003	Electronics	VII LTD. TAIWAN BRANCH
1 PLC ±0.25		A. WU	NAME	
2 PLC ±0.13		27-JUN-2003		
3 PLC ±0.05				
ANGLES ±3	MATERIAL	APVD	J. CHENG	MINI USB RIGHT ANGLE, SMT, B TYPE
	SEE NOTE	PRODUCT SPEC	27-JUN-2003	
		108-57062		
	FINISH	APPLICATION SPEC	LOC	SIZE
	SEE NOTE		DW	A3
		WEIGHT	SCALE	DRAWING NO
				C-440247
				REV
				D
				SHEET
				1 OF 4

PRINT DW
 THIS INFORMATION IS CONFIDENTIAL AND IS DISCLOSED TO YOU ON CONDITION THAT NO PARTS OR DIMENSIONS BE MADE BY YOU TO OTHER THAN AMP PERSONNEL WITHOUT DIMENSION IN MILLIMETERS. DO NOT SCALE PRINT.

D	ADD P/N FOR PACKAGE	F200-0149-03	CH	04JUL 2003
LTR	REVISION RECORD	ECN	DWN	CHK
			DATE	

8 | 7 | 6 | 5 | 4 | 3 | 2 | 1 | CUSTOMER DRAWING

NUMBER C-440247



METRIC

PRINT DIST DW THIS INFORMATION IS CONFIDENTIAL AND IS DISCLOSED TO YOU ON CONDITION THAT NO FURTHER DISCLOSURE IS MADE BY YOU TO OTHER THAN AMP PERSONNEL WITHOUT THE WRITTEN PERMISSION OF AMP. DIMENSION IN MILLIMETERS. DO NOT SCALE PRINT.

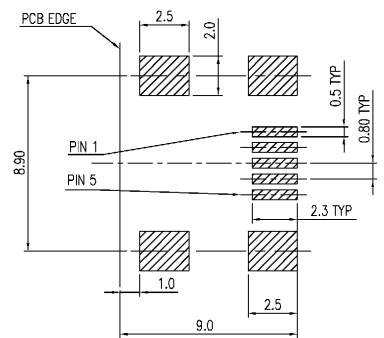
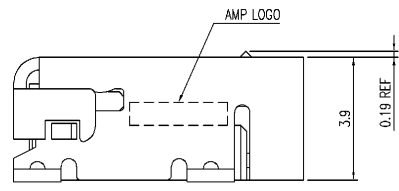
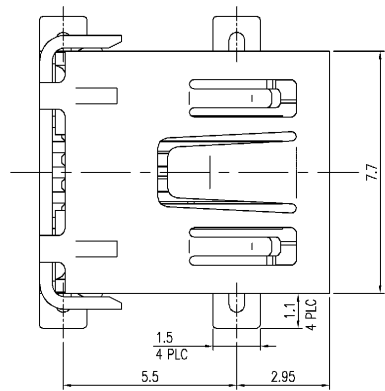
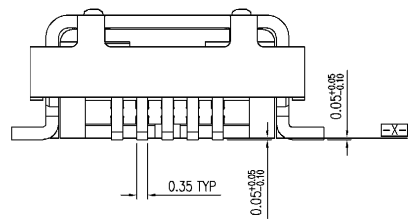

RECOMMENDED PCB LAYOUT (MOUNTING SIDE)
THICKNESS 1.57mm

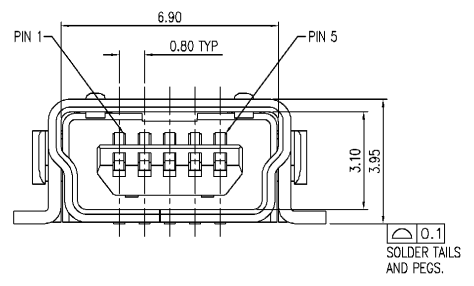

W/O	W/	TAPE REEL	W/O	1-440247-3
	W/O	TAPE REEL	W/O	1-440247-2
	N/A	TRAY	W/O	1-440247-1
MYLAR	LONG CARRIER & COVER TAPE	PACKAGE	POST	PART NUMBER

DIMENSION :	DWN	O. HU		TYCO HOLDINGS (BERMUDA) VII LTD. TAIWAN BRANCH
	0 PLC ±0.38	27-JUN-2003		
1 PLC ±0.25	CHK	A. WU	NAME	
2 PLC ±0.13		27-JUN-2003	MINI USB RIGHT ANGLE, SMT, B TYPE	
3 PLC ±0.05	MATERIAL	APVD	J. CHENG	
ANGLES ±3	SEE SHEET 1.	PRODUCT SPEC	27-JUN-2003	
	FINISH	APPLICATION SPEC	LOC	DRAWING NO
	SEE SHEET 1.	WEIGHT	DW	C-440247
			SCALE	REV D
				2 OF 4

SEE SHEET 1.	ECN	DWN	CHK	DATE
LTR	REVISION RECORD			

CUSTOMER DRAWING

NUMBER C-440247



METRIC

PRINT DW
THIS INFORMATION IS CONFIDENTIAL AND IS DISCLOSED TO YOU ON CONDITION THAT NO FURTHER DISCLOSURE IS MADE BY YOU TO OTHER THAN AMP PERSONNEL WITHOUT THE WRITTEN PERMISSION OF AMP. DO NOT SCALE PRINT.

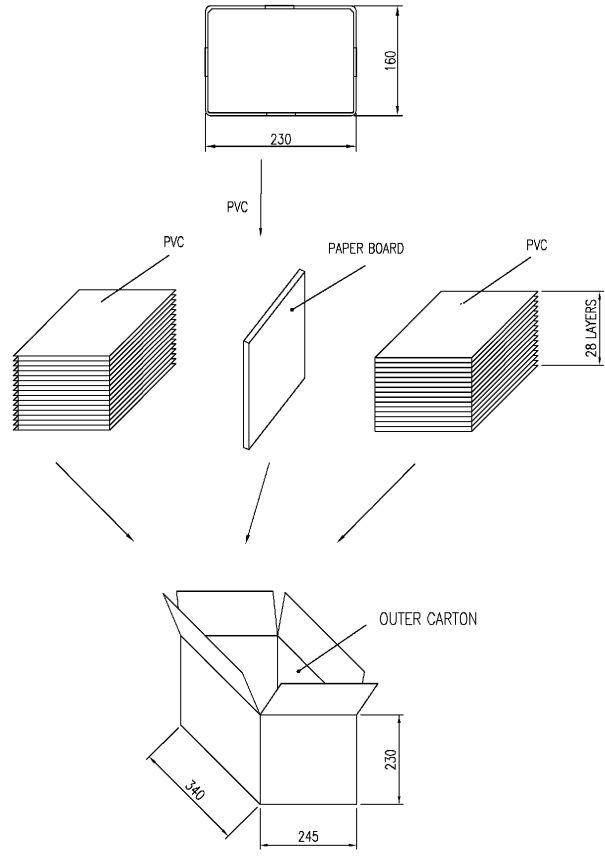

9.2	6.7	8400 (56 TRAY)	150	1-440247-1 440247-1
G.W(KGS)	N.W(KGS)	PACKAGING QTY' / CARTON	PCS/TRAY	PART NUMBER
DIMENSION :		DWN	O. HU	 TYCO HOLDINGS (BERMUDA) VII LTD. TAIWAN BRANCH
0 PLC	1 PLC	27-JUN-2003	27-JUN-2003	
2 PLC	3 PLC	27-JUN-2003	27-JUN-2003	NAME
ANGLES				MINI USB RIGHT ANGLE, SMT, B TYPE
MATERIAL		APVD	J. CHENG	LOC SIZE DRAWING NO DW A3 C-440247 SCALE SHEET
		PRODUCT SPEC	27-JUN-2003	
FINISH		APPLICATION SPEC		REV D
		WEIGHT		3 OF 4

SEE SHEET 1.				
LTR	REVISION RECORD	ECN	DWN_CHK	DATE

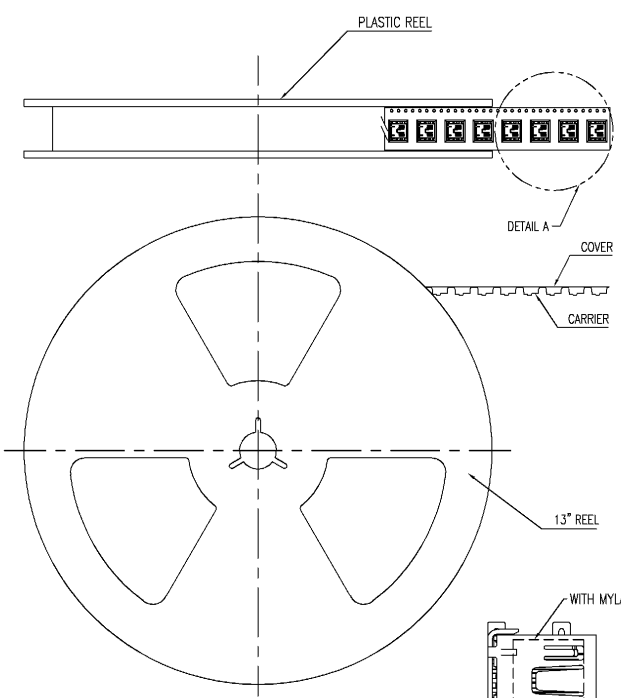
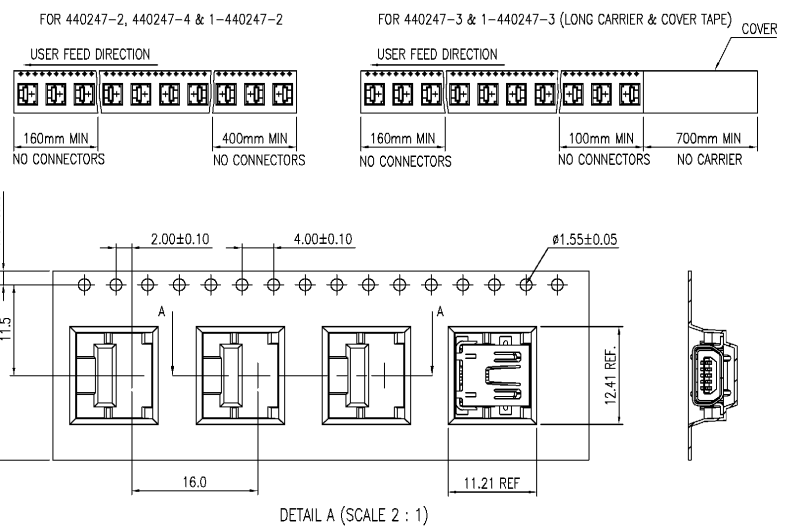
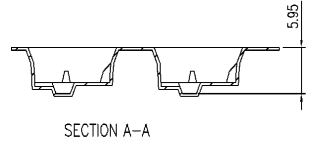

FIGURE E



DETAIL A (SCALE 2 : 1)



SECTION A-A

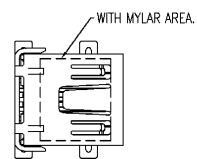

VIEW A (SEE NOTES 4)

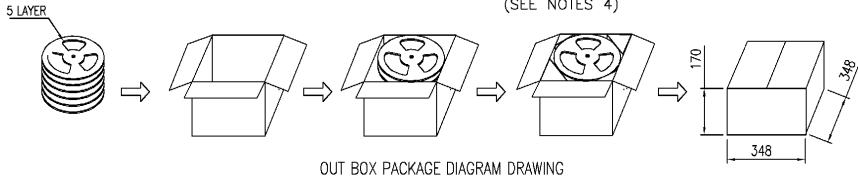

OUT BOX PACKAGE DIAGRAM DRAWING

- NOTES:
1. APPLICABLE DOCUMENT : EIA-481-2
 2. PACKAGE: 700 PCS/REEL , 5 REEL/BOX
W.G. : 6.5Kg , N.G. : 5.5Kg
 3. QUANTITY: 3500 PCS.
 4. VIEW SHOW THE MYLAR AREA FOR P/N 440247-4

W/O	W/	1-440247-3
W/O	W/O	1-440247-2
W/	W/O	440247-4
W/O	W/	440247-3
W/O	W/O	440247-2
MYLAR	LONG CARRIER & COVER TAPE	PART NUMBER

DIMENSION :	DWN	O. HU	TYCO Electronics	TYCO HOLDINGS (BERMUDA) VII LTD. TAIWAN BRANCH
0 PLC	27-JUN-2003	27-JUN-2003	NAME	
1 PLC			A. WU	
2 PLC			27-JUN-2003	
3 PLC			J. CHENG	
ANGLES			27-JUN-2003	
MATERIAL	APVD			MINI USB RIGHT ANGLE, SMT, B TYPE
	PRODUCT SPEC			
FINISH	APPLICATION SPEC		LOC	SIZE
	WEIGHT		DW	A3
			SCALE	DRAWING NO
				C-440247
				REV
				D
				SHEET
				4 OF 4

SEE SHEET 1.				
LTR	REVISION RECORD	ECN	DWN_CHK	DATE