

MATERIAL NUMBER (STD.)	MATERIAL NUMBER (-56)	MATERIAL NUMBER (-50)	NO. OF CIRCUITS	A	B
386306602	386390109	386307802	2	25.9 (1.02)	11.13 (.438)
386306603	386390110	386307803	3	37.1 (1.46)	22.22 (.875)
386306604	386390111	386307804	4	48.3 (1.90)	33.35 (1.313)
386306605	386390112	386307805	5	59.2 (2.33)	44.45 (1.750)
386306606	386390113	386307806	6	70.4 (2.77)	55.57 (2.188)
386306607	386390114	386307807	7	81.5 (3.21)	66.67 (2.625)
386306608	386390115	386307808	8	92.7 (3.65)	77.80 (3.063)
386306609	386390116	386307809	9	103.6 (4.08)	88.90 (3.500)
386306610	386390117	386307810	10	114.8 (4.52)	100.03 (3.938)
386306611	386390118	386307811	11	125.9 (4.96)	111.13 (4.375)
386306612	386390119	386307812	12	137.2 (5.40)	122.25 (4.813)
386306613	386390120	386307813	13	148.1 (5.83)	133.35 (5.250)
386306614	386390121	386307814	14	159.3 (6.27)	144.45 (5.687)
386306615	386390122	386307815	15	170.4 (6.71)	155.58 (6.125)
386306616	386390123	386307816	16	181.6 (7.15)	166.70 (6.563)

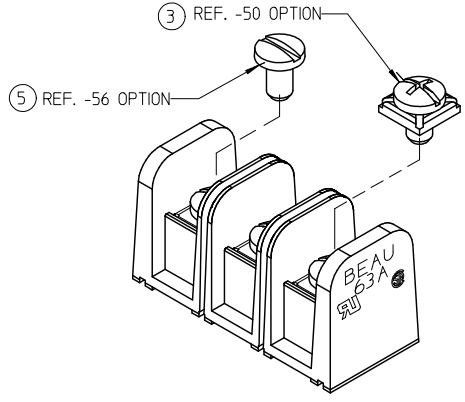
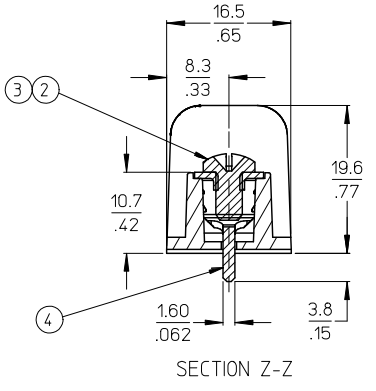
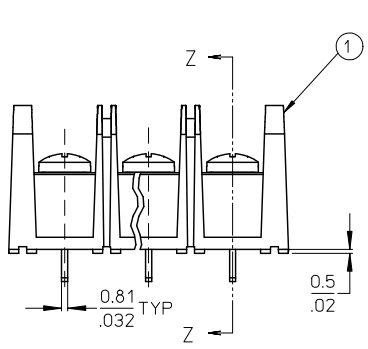

- NOTES:
1. MATERIAL: SEE TABLE
  2. FINISHES: SEE TABLE
  3. PRODUCT SPECIFICATION: NOT REQUIRED
  4. PACKAGING: NOT REQUIRED
  5. MATES WITH: NONE
  6. \*XX\* REFERS TO QTY. OF CIRCUITS
  7. ROHS COMPLIANT (C)

ITEM	QTY.	DESCRIPTION	MATERIAL	FINISH
5	XX	SCREW #6-32X.250 BHD, SLOT STAINLESS (-56 OPT)	STAINLESS STL	PASSIVATE
4	XX	TERMINAL, PC (SHORT)	BRASS	TIN PLATE
3	XX	SCREW/WSHR #6-32X.250 PAN, PH-SL (-50)	STEEL (C)	ZN, CLEAR CHROMATE
2	XX	SCREW #6-32X.250 BHD, PH-SL (STD)	STEEL (C)	ZN, CLEAR CHROMATE
1	1	BARRIER TERMINAL STRIP (C)	POLYESTER (PBT)	BLACK

UPDATE MAT. DESCRIPT.  
 IEC NO: WNA2009-0085  
 DRWN: JENCINAS 2008/11/25  
 CHKD: CYRIL 2008/12/15  
 APPR: JMACNEIL 2008/12/15

QUALITY SYMBOLS  
 ▽=0  
 ▽=0

GENERAL TOLERANCES (UNLESS SPECIFIED)	
4 PLACES ±	--- ±
3 PLACES ±	--- ± .005
2 PLACES ±	0.13 ± .01
1 PLACE ±	0.3 ± ---
ANGULAR ± 2 °	

DRAFT WHERE APPLICABLE  
 MUST REMAIN WITHIN DIMENSIONS

DIMENSION STYLE	
MM/IN	
DRAWN BY	DATE
R. STONE	2003/03/25
CHECKED BY	DATE
R. KEMP	2003/03/27
APPROVED BY	DATE
P. WALIZ	2003/03/28

SCALE	DESIGN UNITS	THIRD ANGLE PROJECTION
2:1	INCH	☉ □
TITLE		
11.13/.438" PCB BTS 600V NO MTG ENDS, STD LENGTH (63A5XX-C)		
MATERIAL NO. MOLEX INCORPORATED		
DOCUMENT NO. SD-38630-008		SHEET NO. 1 OF 1
THIS DRAWING CONTAINS INFORMATION THAT IS PROPRIETARY TO MOLEX INCORPORATED AND SHOULD NOT BE USED WITHOUT WRITTEN PERMISSION		