

## Mobile Pentium<sup>™</sup> II Power Supply Evaluation Board 90% Peak Efficiency Achieved

The new IRNBPS1 evaluation board offers the power supply designer a convenient way to evaluate power MOSFET performance in DC/DC converters powering next-generation mobile processors. A synchronous buck regulator topology operating at 300 kHz is employed. A DAC selectable output voltage allows evaluation at various voltages for existing and forthcoming mobile processors.

The new 30V low threshold SO-8 IRF7805 and IRF7807 HEXFET<sup>®</sup> MOSFETs, specifically designed for the application, are used to improve circuit efficiency through reduced  $R_{DS(on)}$  and gate charge. The IRF7805 and IRF7807 are optimized for switching and conduction losses under the operating range. A detailed schematic along with complete efficiency and thermal performance characterization are offered to reduce the customer's test and verification time when designing with IR MOSFETs.

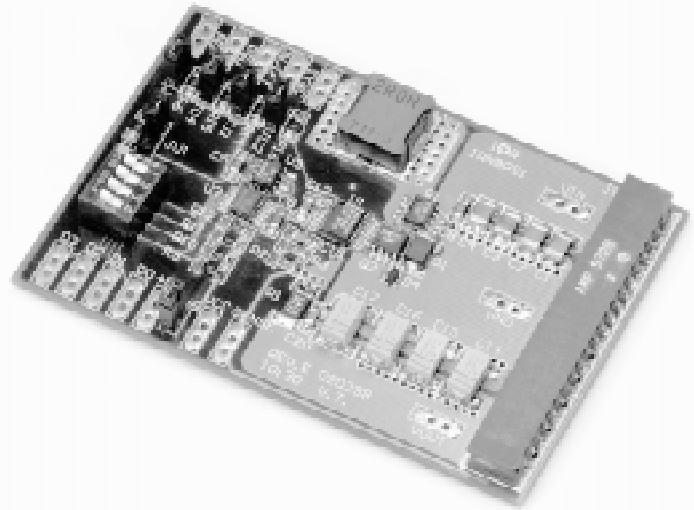

Fig 1. IRNBPS1

### Purpose

This evaluation tool is available to power supply designers to verify and qualify the performance of IR power MOSFETs under "real world" mobile CPU DC/DC converter conditions.

### Web Site

This evaluation board datasheet as well as the IRF7805 and IRF7807 datasheets may be downloaded at IR's web site (<http://www.irf.com>). Datasheets are in PDF format for on screen viewing or printing.

### Evaluation Boards

Evaluation boards are available through your local IR sales office in the Mobile Pentium<sup>™</sup> II Design Kit - order as IRNBPS1.

### Support

E-mail Chris Davis at [cdavis1@irf.com](mailto:cdavis1@irf.com) for support of this evaluation board and the IRF7805 and IRF7807 MOSFETs.

### Key Features

- 90% Peak Efficiency @  $10V_{in}$
- Designed for new mobile Pentium<sup>™</sup> II processors.
- Accepts input voltages from 10V to 24V
- 1.25 to 2.00V digitally selectable output
- Up to 7A continuous output
- Complete efficiency characterization
- Complete thermal characterization
- Design kit available: IRNBPS1

## Specifications

### Absolute Maximum Ratings

Table 1

Parameter	Min	Max	Units
Input Voltage	-	30.0	V
Digital I/O	-0.3	+6.0	V
Continuous Output Current	-	8.5	A

### Efficiency, Typical

Parameter	V <sub>in</sub> = 10V	V <sub>in</sub> = 14V	V <sub>in</sub> = 24V	Units
$\eta_{peak}$ , V <sub>out</sub> = 1.6V, Fixed PWM	90	88.5	83.5	%
$\eta$ @ I <sub>out</sub> = 5.6A, V <sub>out</sub> = 1.6V, Fixed PWM	86.8	85.8	82	%

### Electrical Input Specifications

Parameter	Min	Typ	Max	Units
Input Voltage	10	14	24	V
Input Current	-	.64	2.0	A

### Power Output Specifications (all specified line and load conditions)

Parameter	Min	Typ	Max	Units
Voltage Range	1.25	1.60	2.0	V
Output Current	0	5.6	7.0	A
Voltage Regulation	-	0.20	1	%

### Digital Input/Output Specifications

Signal	Input/Output	Conditions/Description
PGD, ON/OFF, DO-D3, SKIP, SYNC	input	Logic

### Output Fault Protection

Parameter	Min	Typ	Max	Units
Over Voltage	+4	+7	+10	%
Over Current	8	10	12	A
Under Voltage	60	70	80	%

## Circuit Description

The IRNBPS1 evaluation board provides a digitally adjustable output voltage between 1.25V and 2V from a 10V to 24 V input supply. The output voltage is digitally adjusted by the MAX5480, a multiplying digital to analog converter (DAC). Refer to Table 2 for the DAC codes.

The IRF7805 and IRF7807 HEXFET Power MOSFETs, as well as the MAX1636 control IC are rated for 30V; however, the design kit is restricted to 24V operating range due to the ratings of other components and minimum duty-factor limitations. The power MOSFETs were specifically designed for optimal efficiency at V<sub>in</sub> = 14V, V<sub>out</sub> = 1.6V, and I<sub>out</sub> = 5.6A, with a 10V-24V input voltage swing, and I<sub>outmax</sub> = 7A (typical 4 cell Lithium-Ion operating conditions). All components were chosen for 300kHz switching frequency.

The MAX1636 Control IC has an internal linear regulator for supplying its own VCC power from the input voltage of the supply. If a 5 volt bus or supply is available, it is recommended to use the "optional +5V" input, instead of the internal linear regulator.

This will decrease gate drive power losses and increase efficiency. To use this option, disconnect pin 13 from its pad or cut the trace, connect jumper JU6, then connect the +5V supply to either the connector pins A4, A5, B4 or to the +5V test point.

## Jumper Description

Table 3: Jumper JU1 Functions

Shunt Location	MAX1636 Gain Pin	Operating Mode
Pin 1, 2	REF	0.5% AC Regulation
Pin 3, 4	VCC	1% AC Regulation
OFF (Recommended)	GND	2% AC Regulation

Table 4: Jumper JU2 Functions

Shunt Location	MAX1636 SKIP Pin	Operating Mode
OFF	GND	Idle mode, pulse skipping operation, for highest light-load efficiency
ON	VCC	Low-noise mode, fixed frequency PWM operation.

Table 5: Jumper JU3 Functions

Shunt Location	MAX1636 SYNC Pin	Frequency (kHz)
OFF	VCC	300
ON	GND	200

Table 2. VID Codes

#	D 3	D 2	D 1	D 0	V <sub>out</sub>
0	0	0	0	0	2.0
1	0	0	0	1	1.95
2	0	0	1	0	1.9
3	0	0	1	1	1.85
4	0	1	0	0	1.8
5	0	1	0	1	1.75
6	0	1	1	0	1.7
7	0	1	1	1	1.65
8	1	0	0	0	1.6
9	1	0	0	1	1.55
10	1	0	1	0	1.5
11	1	0	1	1	1.45
12	1	1	0	0	1.4
13	1	1	0	1	1.35
14	1	1	1	0	1.3
15	1	1	1	1	1.25

Table 6: Jumper JU4 Functions

Shunt Location	MAX1636 OVP Pin	Over-Voltage Protection
OFF	VCC	Enabled
ON	GND	Disabled

Table 7: Jumper JU5 Functions

Shunt Location	MAX1636 SHDN Pin	MAX1636 Output
ON	GND	Shutdown mode, V <sub>out</sub> = 0V
OFF	VIN	Enabled

### Latched Fault Protection

The MAX1636 contains a latched fault-protection circuit that disables the IC when the output is over-voltage or under-voltage (or when thermal shutdown is triggered). Once disabled, the supply won't attempt to restart until input power is cycled or until SHDN(JU5) is cycled. A fault condition can be triggered by overloading the output, over-volting the output (which can happen when changing the DAC code settings), or by touching sensitive compensation or feedback nodes.

Fig 2. IRNBPS1 Schematic Diagram

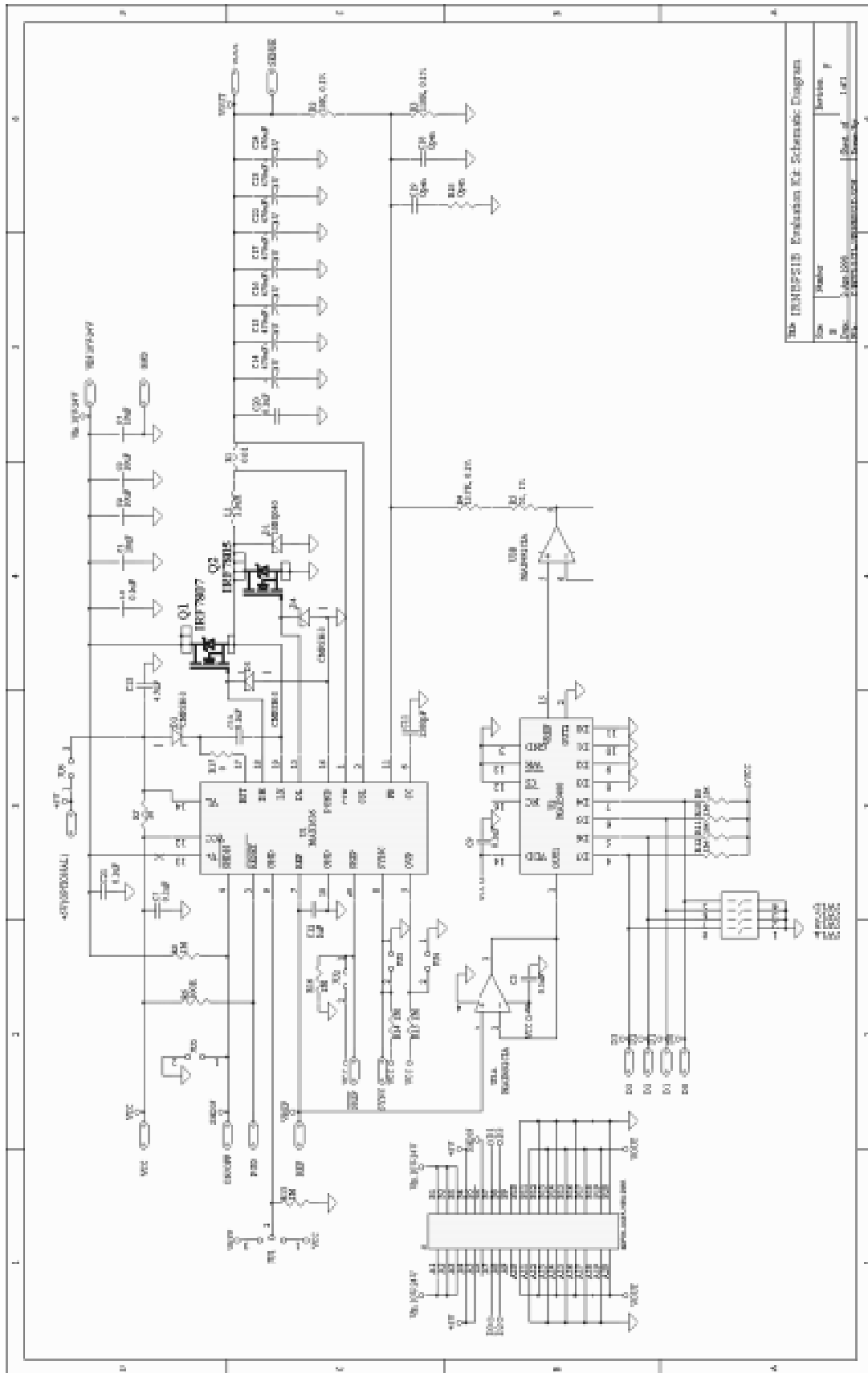

## Static Performance

### Efficiency

High efficiency is expected in a mobile CPU converter. Thanks to the application specific IRF7805 & IRF7807 MOSFETs, the efficiency is kept high throughout low load

to full load at  $V_{out} = 1.6V$  (Figure 3). Efficiency could be boosted up if the sense resistor was eliminated as in voltage mode schemes (Figure 4).

The efficiency also increases if the output voltage is raised to 1.8V, such as for existing CPU voltage rails (Figure 5).

Fig 3. Typical Efficiency, Constant Frequency PWM  
 $V_{out} = 1.6V$ ,  $f_s = 300kHz$ , +5V ext.

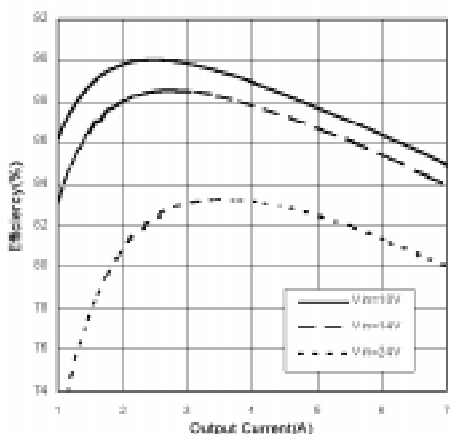

Fig 4. Calculated Efficiency with  $R_{SENSE}$  Removed, PWM  
 $V_{out} = 1.6V$ ,  $f_s = 300kHz$ , +5V ext.

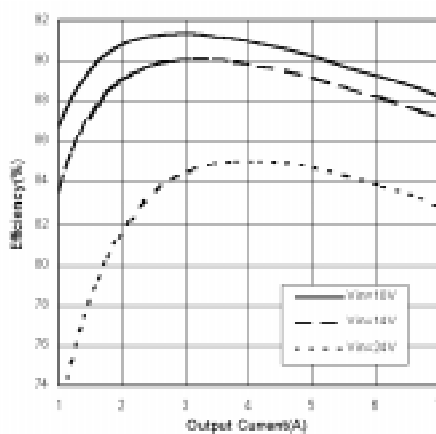

Fig 5. Typical Efficiency, Constant Frequency PWM  
 $V_{out} = 1.8V$ ,  $f_s = 300kHz$ , +5V ext.

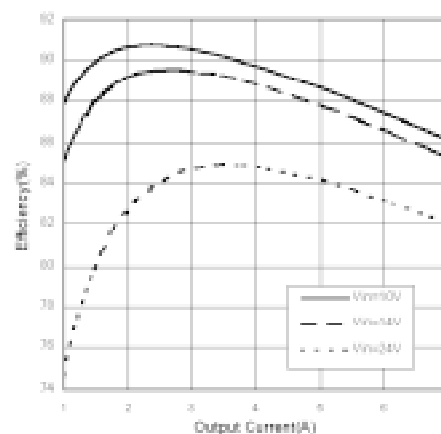
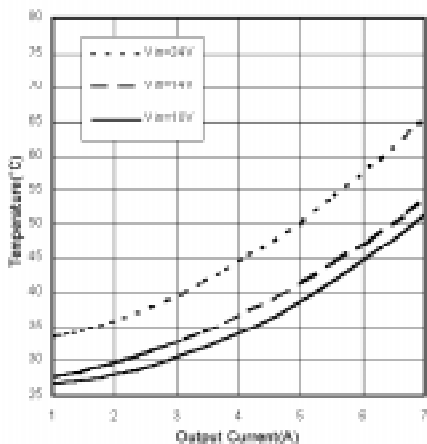

Fig 6. Typical  $T_j$  of Q1  $T_a = 25^\circ C$ ,  $V_{out} = 1.6V$   
(still air)



**Maximum Junction Temperature**  
Measurement of Q1 & Q2 junction temperatures shows that they remain low at an ambient temperature of 25°C, even in still air. Operation under 50°C ambient will maintain sufficient margin under the component temperature ratings.

Fig 7. Typical  $T_j$  of Q2  $T_a = 25^\circ C$ ,  $V_{out} = 1.6V$   
(still air)

