

PRODUCT NUMBER
SEE TABLE

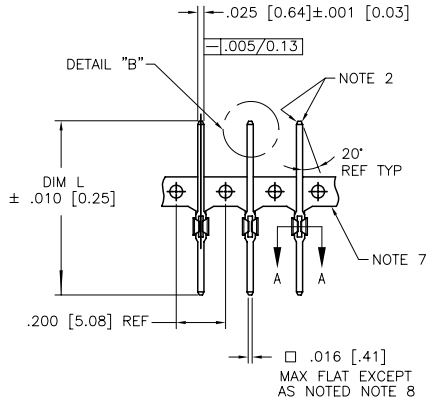

TWO SIDES OF LEAD-IN
NOT PLATED
TYP BOTH ENDS

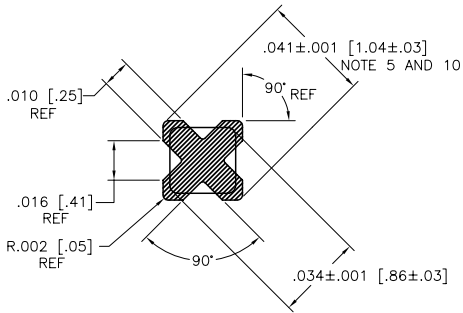
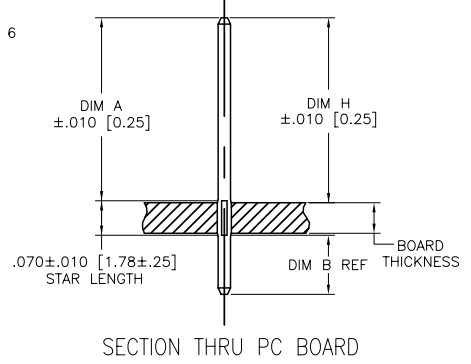
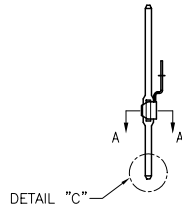

SECTION A-A
SCALE 10:1
(FERRULE REMOVED)

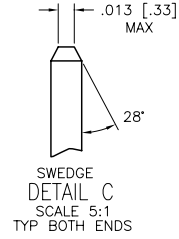
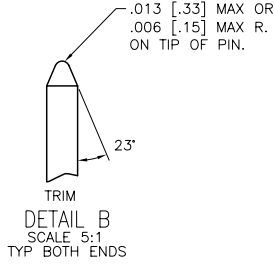

mat'l. code	surface	tolerance	projection	product family	
SEE NOTE 1	ASME Y14.5 ✓	ASME Y14.5		PIN PRODUCTS	
ltr	ec'n no	dr	date	tolerances unless otherwise specified	
AK	V07-0009	HTB	2007-01-05	angles	
AL	V08-0354	HTB	2008-08-21	XXX+01/XX+3	
-	-	-	-	XXX+005/XXX+3	
-	-	-	-	XXX+0020/XXX+051	
AF	V01594	JRW	2000-07-12	dr	
AG	V11062	CGD	2001-03-15	eng'r	
AH	V05-0375	VS	2005-04-22	chr	
AJ	V06-0684	HTB	2006-07-24	app'd	
sheet	revision	AL	AL	AL	AL
index	sheet	1	2	3	4

INCH/MM	scale	product family	title
INCH/MM	2:1	PIN PRODUCTS	BERGPIN® .200"[5.08]cc
			.041"[1.04] DIA. STAR
		dwg no	75481
		sheet	1 of 4
		size	A4
		type	CUSTOMER Drawing



PRODUCT NUMBER NOTE 12	PLATING	UNDERPLATING
75481-YYY	30μ" [0.76μ] MIN Au	50μ" [1.27μ] MIN Ni
75481-YYLFF		
75482-YYY	U N A S S I G N E D	
75483-YYY	50μ" [1.27μ] MIN Au	50μ" [1.27μ] MIN Ni
75483-YYLFF		
75484-YYY	120μ" [3.05μ] MIN 93/7 SnPb	50μ" [1.27μ] MIN Ni
75484-YYLFF	100μ" [2.54μ] MIN Sn	50μ" [1.27μ] MIN Ni
75485-YYY	30μ" [0.76μ] MIN GXT™	50μ" [1.27μ] MIN Ni
75485-YYLFF		
75486-YYY	15μ" [0.38μ] MIN GXT™	50μ" [1.27μ] MIN Ni
75486-YYLFF		
75487-YYY	U N A S S I G N E D	
75488-YYY	U N A S S I G N E D	
75489-YYY	15μ" [0.38μ] MIN Au	50μ" [1.27μ] MIN Ni
75489-YYLFF		

NOTE 14- OBSOLETE
NOTE 13

NOTES:

- ① PIN MATERIAL: PHOS BRONZE 3/4 HARD
ASTM-B-159-66
- ② BURNISH MARKS ON PIN PERMITTED, BURR
.003/.08 MAX BULGE .0005 [0.013] TYP.
3. SEE PRODUCT SPECIFICATION BUS-12-064 FOR
P.C. BOARD HOLE DIAMETER AND P.C. BOARD
HOLE PLATING INFORMATION.
4. PIN TO FERRULE RETENTION 1 LB [0.45 KG] MIN
TO 6 LBS [2.72 KG] MAX.
- ⑤ THE .041±.001 [1.04±.03] FEATURE SHALL
BE CONCENTRIC TO THE WIRE DIAGONAL WITHIN
.004 [0.10] TIR.
- ⑥ .002 [0.05] R MAX TYP 4X ON WIRE WRAP
PORTION OF PIN.
- ⑦ CARRIER STRIP FOR CONVEYING PURPOSES ONLY.
- ⑧ DOUBLE ENDED PINS AS MARKED MUST MEET
SPECS IN VIEWS B & C ON BOTH ENDS.
9. USE FIRST TWO DIGITS OF "H" DIMENSIONS
FOR DASH NUMBER OF PUNCH FROM MACHINE
EPL:
EXAMPLE:
P/N 75481-001 PUNCH P/N FROM EPL
BP161A-105396-028
"BD" = .062 [1.58] BP151-133632-028
"H" = .283 [7.19] BP171-133632-028
- ⑩ SPECIAL STAR .044 ±.002 [1.12 ±.05] WIDE X .060 [1.52] LONG
FOR DASH NUMBER [-048] ONLY.
11. CENTER LINE OF TERMINAL MUST BE IN A
TRUE POSITION WITHIN .016 [0.41] DIA WITH
RESPECT TO THE HOLE AXIS AFTER INSERTION
IN PC BOARD.
- ⑫ ADD AN LF SUFFIX TO PART NUMBER FOR PRODUCT THAT
MEETS EUROPEAN UNION DIRECTIVES AND OTHER COUNTRY
REGULATIONS AS DESCRIBED IN GS-022-008.
- ⑬ THIS PRODUCT HAS 100% TIN PLATING IN THE INTERFACE AND HAS NOT BEEN
TESTED FOR WHISKER GROWTH IN ALL INTERCONNECT ENVIRONMENTS.
- ⑭ 75484-YYY IS NOT RoHS COMPLIANT.

mat'l code	surface	tolerance	projection	product family
SEE NOTE 1	ASME Y14.5 ✓	ASME Y14.5		PIN PRODUCTS
tr ecn no dr date	tolerances unless otherwise specified		INCH/MM	title
AL	angles	XXX+01/XX+3	scale 1:1	BERGPIN® .200"[5.08]cc .041"[1.04] DIA. STAR
	0°±2'	XXXX+0020/XXX+051		dwg no 75481 sheet 2 of 4 size A4
	dr S. ROYER 1994-07-20			type CUSTOMER Drawing
	enrg L. FYE 1994-07-20			
	chr L. FYE 1994-07-20			
	appd L. FYE 1994-07-20			
sheet index	revision sheet			

Copyright FCJ



FCJconnect.com

PRODUCT NUMBER NOTE 12	CONTACT AREA		TERM. AREA		OVERALL LENGTH		DIM H FOR .062/1.58 BOARD		DIM H FOR .093/2.36 BOARD		DIM H FOR .125/3.18 BOARD		NOTES
	DIM A ENGLISH	DIM A METRIC	DIM B ENGLISH	DIM B METRIC	DIM L ENGLISH	DIM L METRIC	ENGLISH	METRIC	ENGLISH	METRIC	ENGLISH	METRIC	
7548X-001	0.278	7.06	0.042	1.07	0.390	9.91	0.283	7.19	0.268	6.81	0.253	6.43	-
7548X-002	0.308	7.82	0.042	1.07	0.420	10.67	0.313	7.95	0.298	7.57	0.283	7.19	-
7548X-003	0.285	7.24	0.075	1.91	0.430	10.92	0.290	7.37	0.275	6.99	0.260	6.60	-
7548X-004	0.315	8.00	0.055	1.40	0.440	11.18	0.320	8.13	0.305	7.75	0.290	7.37	-
7548X-005	0.315	8.00	0.075	1.91	0.460	11.68	0.320	8.13	0.305	7.75	0.290	7.37	-
7548X-006	0.368	9.35	0.042	1.07	0.480	12.19	0.373	9.47	0.358	9.09	0.343	8.71	-
7548X-007	0.375	9.53	0.055	1.40	0.500	12.70	0.380	9.65	0.365	9.27	0.350	8.89	-
7548X-008	0.315	8.00	0.125	3.18	0.510	12.95	0.320	8.13	0.305	7.75	0.290	7.37	NOTE 8
7548X-009	0.405	10.29	0.042	1.07	0.517	13.13	0.410	10.41	0.395	10.03	0.380	9.65	-
7548X-010	0.315	8.00	0.155	3.94	0.540	13.72	0.320	8.13	0.305	7.75	0.290	7.37	NOTE 8
7548X-011	0.428	10.87	0.042	1.07	0.540	13.72	0.433	11.00	0.418	10.62	0.403	10.24	-
7548X-012	0.475	12.07	0.055	1.40	0.600	15.24	0.480	12.19	0.465	11.81	0.450	11.43	-
7548X-013	0.405	10.29	0.135	3.43	0.610	15.49	0.410	10.41	0.395	10.03	0.380	9.65	NOTE 8
7548X-014	0.508	12.90	0.042	1.07	0.620	15.75	0.513	13.03	0.498	12.65	0.483	12.27	-
7548X-015	0.698	17.73	0.042	1.07	0.810	20.57	0.703	17.86	0.688	17.48	0.673	17.09	-
7548X-016	0.760	19.30	0.040	1.02	0.870	22.10	0.763	19.38	0.748	19.00	0.733	18.62	-
7548X-017	0.315	8.00	0.255	6.48	0.640	16.26	0.320	8.13	0.305	7.75	0.290	7.37	NOTE 8
7548X-018	0.405	10.29	0.055	1.40	0.530	13.46	0.410	10.41	0.395	10.03	0.380	9.65	-
7548X-019	0.443	11.25	0.315	8.00	0.828	21.03	0.448	11.38	0.433	11.00	0.418	10.62	NOTE 8
7548X-020	0.631	16.03	0.315	8.00	1.016	25.81	0.636	16.15	0.621	15.77	0.606	15.39	NOTE 8
7548X-021	0.315	8.00	0.179	4.55	0.564	14.33	0.320	8.13	0.305	7.75	0.290	7.37	NOTE 8
7548X-022	0.625	15.88	0.245	6.22	0.940	23.88	0.630	16.00	0.615	15.62	0.600	15.24	NOTE 8
7548X-023	0.230	5.84	0.045	1.14	0.345	8.76	0.235	5.97	0.220	5.59	0.205	5.21	-
7548X-024	0.575	14.61	0.045	1.14	0.690	17.53	0.580	14.73	0.565	14.35	0.550	13.97	-
7548X-025			U N A	S S I G	N E D								
7548X-026	0.625	15.88	0.355	9.02	1.050	26.67	0.630	16.00	0.615	15.62	0.600	15.24	NOTE 8
7548X-027			U N A	S S I G	N E D								

mat'l code	SEE NOTE 1	surface	tolerance	projection	product family
AL	ecm no	ASME Y14.5 ✓	ASME Y14.5		PIN PRODUCTS
	dr	tolerances unless otherwise specified		INCH/MM	title
	date	angles	XXX+01/XX+3	scale 1:1	BERGPIN® .200"[5.08]cc
		0°±2'	XXX+005/XX+3		.041"[1.04] DIA. STAR
			XXXX+0020/XXX+051		dwg no
		dr	S. ROYER		75481
		engr	L. FYE		sheet 3 of 4
		chr	L. FYE		size A4
		appd	L. FYE		type
sheet index	revision sheet				CUSTOMER Drawing

form A4mmXc

Copyright FCJ



FCJconnect.com

1 | 2

3 |

4

PRODUCT NUMBER	CONTACT AREA		TERM. AREA		OVERALL LENGTH		DIM H FOR .062/1.58 BOARD		DIM H FOR .093/2.36 BOARD		DIM H FOR .125/3.18 BOARD		NOTES
	DIM A	DIM A	DIM B	DIM B	DIM L	DIM L	ENGLISH	METRIC	ENGLISH	METRIC	ENGLISH	METRIC	
NOTE12	ENGLISH	METRIC	ENGLISH	METRIC	ENGLISH	METRIC	ENGLISH	METRIC	ENGLISH	METRIC	ENGLISH	METRIC	
7548X-028			U N A	S S I G	N E E D								
7548X-029	0.755	19.18	0.337	8.56	1.162	29.51	0.760	19.30	0.745	18.92	0.730	18.54	NOTE 8
7548X-030	0.490	12.45	0.140	3.56	0.700	17.78	0.495	12.57	0.480	12.19	0.465	11.81	NOTE 8
7548X-031	0.590	14.99	0.140	3.56	0.800	20.32	0.595	15.11	0.580	14.73	0.565	14.35	NOTE 8
7548X-032	0.298	7.57	0.052	1.32	0.420	10.67	0.303	7.70	0.288	7.32	0.273	6.93	-
7548X-033	0.398	10.11	0.042	1.07	0.510	12.95	0.403	10.24	0.388	9.86	0.373	9.47	-
7548X-034	0.468	11.89	0.042	1.07	0.580	14.73	0.473	12.01	0.458	11.63	0.443	11.25	-
7548X-035	0.468	11.89	0.502	12.75	1.040	26.42	0.473	12.01	0.458	11.63	0.443	11.25	NOTE 8
7548X-036	0.305	7.75	0.315	8.00	0.690	17.53	0.313	7.95	0.298	7.57	0.283	7.19	NOTE 8
7548X-037	0.448	11.38	0.042	1.07	0.560	14.22	0.453	11.51	0.438	11.13	0.423	10.74	-
7548X-038	0.228	5.79	0.042	1.07	0.340	8.64	0.233	5.92	0.218	5.54	0.203	5.16	-
7548X-039	0.628	15.95	0.042	1.07	0.740	18.80	0.633	16.08	0.618	15.70	0.603	15.32	-
7548X-040	0.288	7.32	0.042	1.07	0.400	10.16	0.293	7.44	0.278	7.06	0.263	6.68	-
7548X-041	0.308	7.82	0.142	3.61	0.520	13.21	0.313	7.95	0.298	7.57	0.283	7.19	NOTE 8
7548X-042	0.285	7.24	0.287	7.29	0.642	16.31	0.290	7.37	0.275	6.99	0.260	6.60	NOTE 8
7548X-043	0.308	7.82	0.212	5.38	0.590	14.99	0.313	7.95	0.298	7.57	0.283	7.19	NOTE 8
7548X-044	0.522	13.26	0.103	2.62	0.695	17.65	0.527	13.39	0.512	13.00	0.497	12.62	-
7548X-045	0.522	13.26	0.538	13.67	1.130	28.70	0.527	13.39	0.512	13.00	0.497	12.62	NOTE 8
7548X-046	0.595	15.11	0.353	8.97	1.018	25.86	0.600	15.24	0.585	14.86	0.570	14.48	NOTE 8
7548X-047	0.325	8.26	0.042	1.07	0.437	11.10	0.330	8.38	0.315	8.00	0.300	7.62	-
7548X-048	0.310	7.87	0.030	0.76	0.400	10.16	0.305	7.75	0.290	7.37	0.275	6.99	NOTE 10
7548X-049	0.310	7.87	0.470	11.94	0.850	21.59	0.315	8.00	0.300	7.62	0.285	7.24	-
7548X-050	0.390	9.91	0.018	0.46	0.478	12.14	0.395	10.03	0.380	9.65	0.365	9.27	-
7548X-051	0.300	7.62	0.018	0.46	0.388	9.56	0.305	25.71	0.290	7.37	0.275	6.99	-
7548X-052	0.309	7.85	0.026	0.66	0.405	10.29	0.314	7.98	0.299	7.59	0.284	7.21	-

mat'l code	SEE NOTE 1	surface	ASME Y14.5	tolerance	ASME Y14.5	projection	product family
ltr	ec'n no	dr	date	tolerances unless otherwise specified			PIN PRODUCTS
AL				angles	XX+01/XX+3	INCH/MM	title
				0'±2'	XXX+005/XXX+13	scale 1:1	BERGPIN® .200"[5.08]cc
				dr	XXXX+0020/XXX+051		.041"[1.04] DIA. STAR
				engr			dwg no
				chr	S. ROYER 1996-05-15		sheet 4 of 4
				appd	L. FYE 1996-05-15		size
					L. FYE 1996-05-15		75481
sheet index	revision sheet						A4
							type
							CUSTOMER Drawing

form A4mmXc

1 |

2 |

3 |

4