

Tous droits strictement réservés. Reproduction ou communication e des tiers
 Interdite sous quelque forme que ce soit sans autorisation écrite du
 Propriétaire de c FCI. Droits de reproduction FCI.
 All rights strictly reserved. Reproduction or issue to third parties in any
 form whatever is not permitted without written authority from the proprietor.
 Property of FCI. Copyright FCI.

PRODUCT NO.
69830

REVISIONS			
REV	DESCRIPTION	BY	DATE
B	ECR LB277	HS	5/12/86
C	EC T20212		10/22/92
D	N05-0038	Jason	2/17/05
E	N05-0056	Jason	3/1/05

PRODUCT NO.	COVER P/N	BASE ASSY P/N	NO. OF POSITION	A	B	C
69830-006(LF)	68118-006	69831-006(LF)	6	12.08	6.35	5.08
69830-008(LF)	68118-008	69831-008(LF)	8	14.62	8.89	7.62
69830-010(LF)	68118-010	69831-010(LF)	10	17.16	11.43	10.16
69830-014(LF)	68118-014	69831-014(LF)	14	22.24	16.51	15.24
69830-016(LF)	68118-016	69831-016(LF)	16	24.78	19.05	17.78
69830-018(LF)	68118-018	69831-018(LF)	18	27.32	21.59	20.32
69830-020(LF)	68118-020	69831-020(LF)	20	29.86	24.13	22.86
69830-024(LF)	68118-024	69831-024(LF)	24	34.94	29.21	27.94
69830-026(LF)	68118-026	69831-026(LF)	26	37.48	31.75	30.48
69830-030(LF)	68118-030	69831-030(LF)	30	42.56	36.83	35.56
69830-034(LF)	68118-034	69831-034(LF)	34	47.64	41.91	40.64
69830-040(LF)	68118-040	69831-040(LF)	40	55.26	49.53	48.26
69830-050(LF)	68118-050	69831-050(LF)	50	67.96	62.23	60.96
69830-060(LF)	68118-060	69831-060(LF)	60	80.56	74.93	73.66
69830-064(LF)	68118-064	69831-064(LF)	64	85.74	80.01	78.74

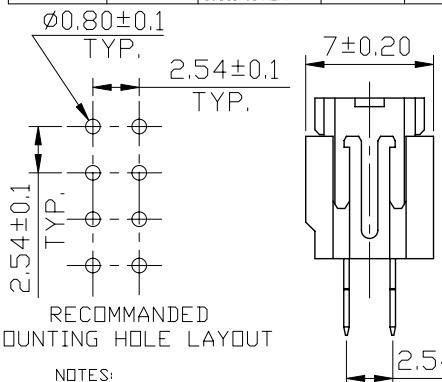
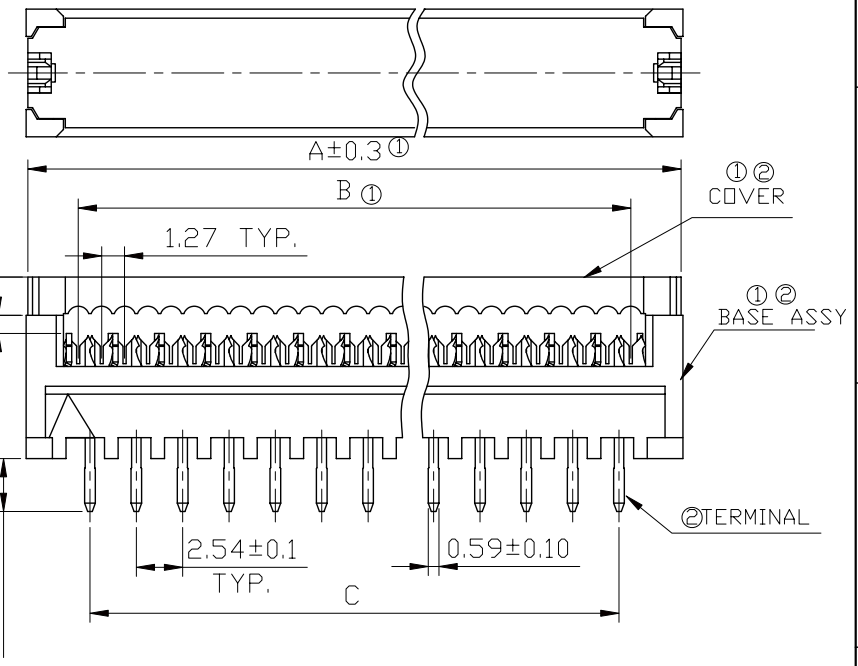

- NOTES:
- ⊕ SEE TABLE.
 - Ⓞ MATERIAL:
 - BASE POLYESTER (PET) GLASS
 - COVER 30% FILLED, UL94V-0. COLOR: BLUE.
 - TERMINAL PHOSPHOR BRONZE.
3. FINISH:
- 69830-***: ALL OVER SnPb PLATING 3.81um MIN. 1.27 um MIN. NI UNDER PLATING.
 - 69830-***LF: ALL OVER PURE Sn PLATING 3.81um MIN. 1.27 um MIN. NI UNDER PLATING.
4. APPLICABLE SPECIFICATIONS:
- PRODUCT SPEC 110-019
 - CRIMPING (I.D.C) SPEC 100-004.
5. CONTACT RETENSION FORCE:
- 400gf/pin MIN. AGAINST THIS DIRECTION.
6. THE HOUSING OF XXXX-XYLF WILL WITHSTAND EXPOSURE TO 260°C PEAK TEMPERATURE FOR 5 SECONDS IN A WAVE SOLDER APPLICATION.

mat'l. code		tolerances unless otherwise specified		CUSTOMER COPY	 www.fciconnect.com
ltr	ecn no	dr	date	linear	
D	N05-0038	ZC	2/17/05	.X ± 0.3	 MM
E	N05-0056	ZC	3/1/05	.XX ± 0.15	
				.XXX ± 0.05	 title QUICKIE DIL PCB CONNECTOR (.100 SHORT LEG)
				angles X±2°	product family QUICKIE code
		dr	Zhengcai Tao 2/17/05		size
		enr	Zhengcai Tao 2/17/05		A4
		chr	Zhengcai Tao 2/17/05	scale 1:1	69830
		appd	Jason Zhou 2/17/05		sheet 1 of 1
sheet index	revision sheet				

PDM: Rev:E STATUS Released Printed: Apr 12, 2011