

Ref. No. 000763

2000/10

SLP ~~_R/S-2~~
Specification
~~SC~~-SLP 01 B

Drawing No.

- ISA28250-2
- ISA28247-3
- ISA28246-3
- ISA28248-3
- ISA28249-3

FCI Japan K. K.

Electronics Division Engineering Section

Certified by *H. Takakura*

H. Takakura
Manager, Engineering Section

CAT. NO. & DIMENSIONS

NO. OF CONTACTS	STRAIGHT TYPE CAT. NO.	RIGHT ANGLE TYPE CAT. NO.	DIMENSIONS(NOTE1)	
			A ±0.3	B ±0.1
4	SLP 4S - 2	SLP 4R - 2	11.15	6.45
5	SLP 5S - 2	SLP 5R - 2	12.40	7.70
6	SLP 6S - 2	SLP 6R - 2	13.65	8.95
7	SLP 7S - 2	SLP 7R - 2	14.90	10.20
8	SLP 8S - 2	SLP 8R - 2	16.15	11.45
9	SLP 9S - 2	SLP 9R - 2	17.40	12.70
10	SLP 10S - 2	SLP 10R - 2	18.65	13.95
11	SLP 11S - 2	SLP 11R - 2	19.90	15.20
12	SLP 12S - 2	SLP 12R - 2	21.15	16.45
13	SLP 13S - 2	SLP 13R - 2	22.40	17.70
14	SLP 14S - 2	SLP 14R - 2	23.65	18.95
15	SLP 15S - 2	SLP 15R - 2	24.90	20.20
16	SLP 16S - 2	SLP 16R - 2	26.15	21.45
17	SLP 17S - 2	SLP 17R - 2	27.40	22.70
18	SLP 18S - 2	SLP 18R - 2	28.65	23.95
19	SLP 19S - 2	SLP 19R - 2	29.90	25.20
20	SLP 20S - 2	SLP 20R - 2	31.15	26.45

CAT. NO.

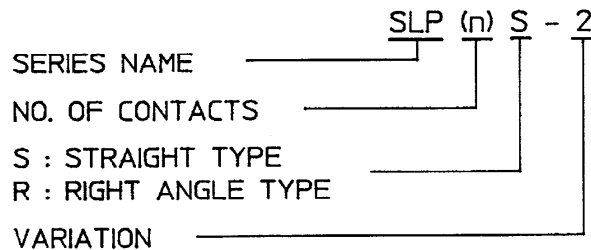

NOTES

1) SEE PART DRAWINGS FOR DIMENSIONS A & B

				SCALE	χ	CAT. NO. TABLE FOR LOW PROFILE ZIFLOK	
				DIM. IN	mm	CAT. NO.	
2	'94 8-26	REDRAWN	<i>m.w.</i>	DESIGNED	<i>S.Y.</i>	SLP__R/S - 2	
REV. DATE	DESCRIPTION	CKD.	DRAWN	<i>m.w. Harada</i>	DRAWING NO.	REV.	
MATERIAL			CHECKED		JSA 28250	2	
			APPROVED	<i>S. Ota</i>			
			DATE	<i>Aug. 26. 1994</i>			

SC SLP01 JSA23246, 28247, 28249, 28249

FILE

TOLERANCES
UNLESS OTHERWISE SPECIFIED : ±0.2

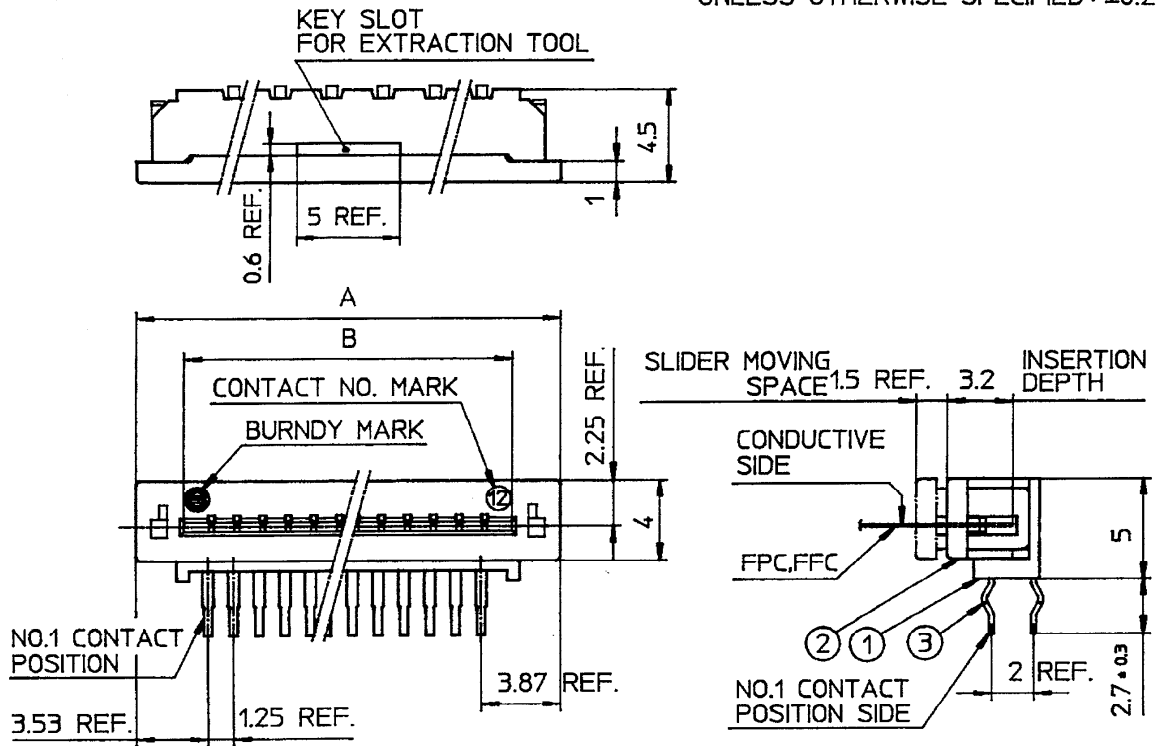

PT. NO.	PARTS NAME	MATERIAL	Q'TY	NOTE
1	HOUSING	PET RESIN GLASS REINFORCED	1	COLOR : BLACK
2	SLIDER	(UL94V-0)	1	COLOR : GRAY
3	CONTACT	PHOSPHOR BRONZE	n	PLATING : TIN ALLOY

n : NO. OF CONTACTS

RECOMMENDED PC BOARD

THICKNESS : 0.8-1.6
HOLE PATTERN (COMPONENT SIDE)

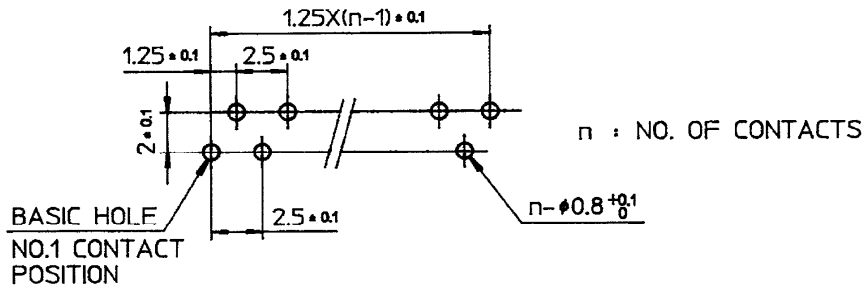

n : NO. OF CONTACTS

				SCALE	X	LOW PROFILE ZIFLOK (RIGHT ANGLE TYPE)	
				DIM. IN	mm	CAT. NO.	
3	'95 1-17	REDRAWN <i>m.o</i>	<i>SJ</i>	DESIGNED		SLP __ R - 2	
REV.	DATE	DESCRIPTION	CKD.	DRAWN	<i>M. Oka</i>	DRAWING NO.	REV.
		MATERIAL		CHECKED	<i>M. Harada</i>	JSA 28247	3
				APPROVED	<i>S.J.T.</i>		
				DATE	Jan. 17, 1995		

JSA28250

FILE

TOLERANCES
UNLESS OTHERWISE SPECIFIED : ±0.2

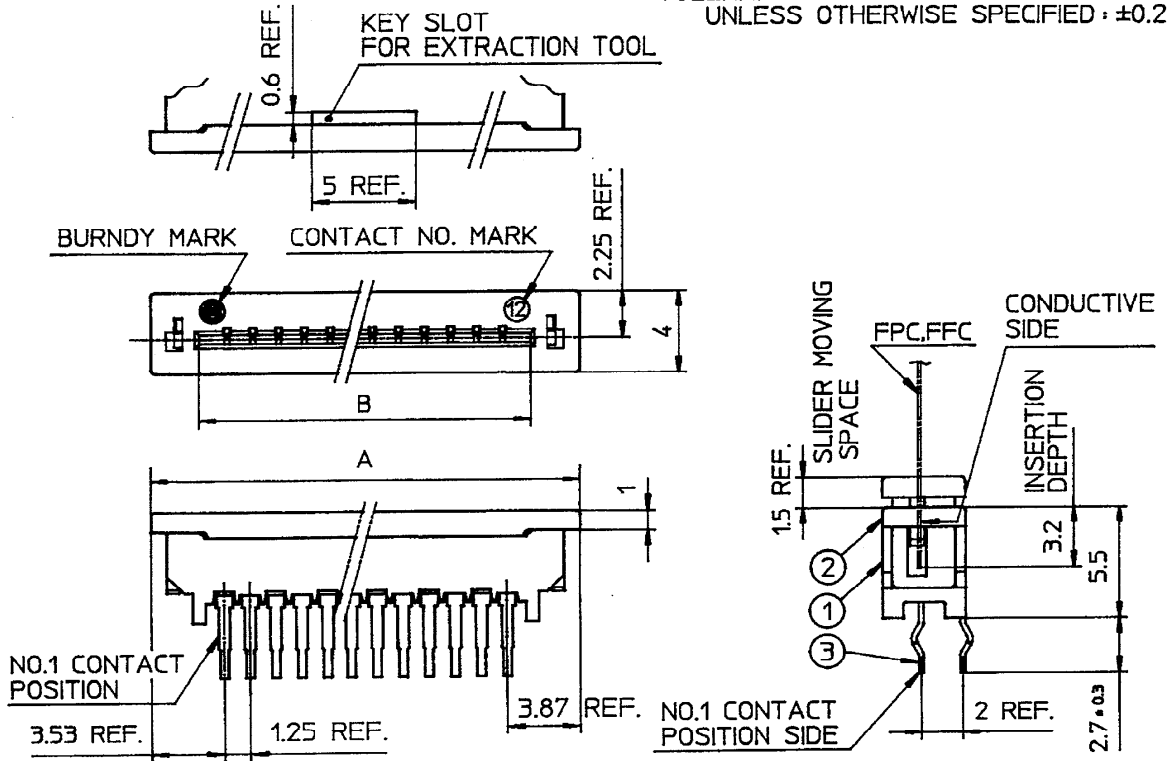

PT. NO.	PARTS NAME	MATERIAL	Q'TY	NOTE
1	HOUSING	PET RESIN GLASS REINFORCED (UL94V-0)	1	COLOR : BLACK
2	SLIDER		1	COLOR : GRAY
3	CONTACT	PHOSPHOR BRONZE	n	PLATING : TIN ALLOY

n : NO. OF CONTACTS

RECOMMENDED PC BOARD

THICKNESS : 0.8-1.6
HOLE PATTERN (COMPONENT SIDE)

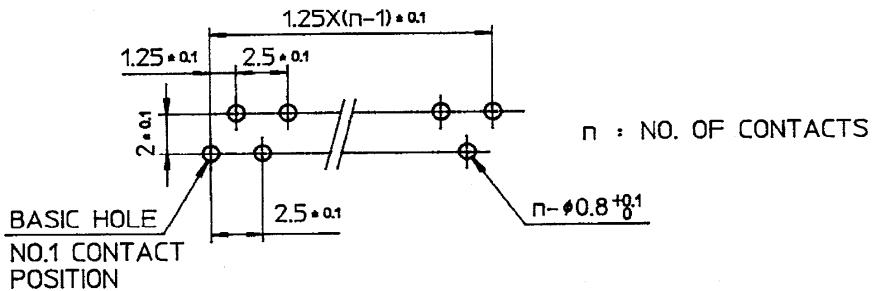

				SCALE	X	LOW PROFILE ZIFLOK (STRAIGHT TYPE)	
				DIM. IN	mm	CAT. NO.	
3	'95 1-17	REDRAWN	SM.0 SQ	DESIGNED	SLP __ S - 2		
REV.	DATE	DESCRIPTION	CKD.	DRAWN	SM. 980	DRAWING NO.	REV.
MATERIAL				CHECKED	mi. Harada	JSA 28246	3
				APPROVED	S. Yoo		
				DATE	JAN. 15, 1995		

JSA28250

FILE

RECOMMENDED CABLE (FPC)

n : NO. OF CONDUCTOR

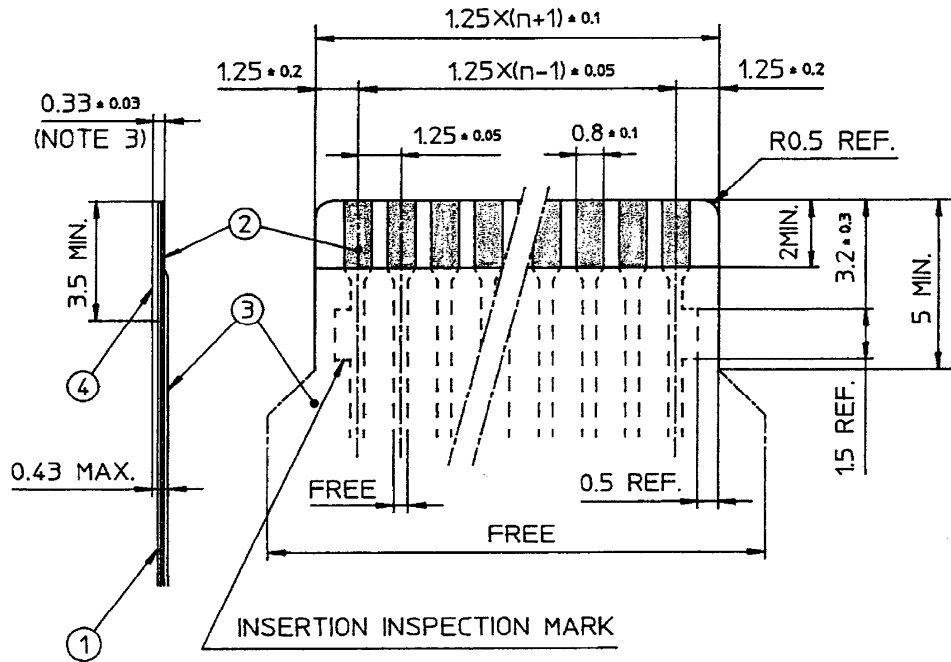

PT. NO.	PARTS NAME	MATERIAL	THICKNESS (μm)
1	BASE FILM	POLYIMIDE OR EQUAL	25
2	CONDUCTOR	COPPER FOIL (PLATING : SOLDER 1μm MIN. 12μm MAX.)	35
3	OVERLAY	POLYIMIDE OR EQUAL	—
4	SUPPORTING TAPE	POLYESTER OR POLYIMIDE OR EQUAL	188

NOTES.

1. NO BURR AT EACH PORTION.
2. NO PEELING IN COMMON USE.
3. TOTAL THICKNESS LIMIT OF EACH MATERIAL (INCLUDING ADHESIVE AGENT) IS SPECIFIED.

REV.	DATE	DESCRIPTION	CKD.	DRAWN	CHECKED	APPROVED	DATE	SCALE	RECOMMENDED CABLE
3	'99 11-29	PLATING THICKNESS CHANGED. M.I.M.Y	H.T	M.Oba	M.Harada	S.Ito	Jan. 13, 1995	SCALE X DIM. IN mm	CAT. NO.
2	'95 1-13	REDRAWN M.O	S.I	M.Oba	M.Harada	S.Ito	Jan. 13, 1995	DESIGNED	SLP__R/S-2
									DRAWING NO.
									JSA 28248
									REV.
									3



