

Tous droits strictement réservés. Reproduction ou communication à des tiers interdite sous quelque forme que ce soit sans autorisation écrite du propriétaire. Property of FCI. Copyright FCI.

All rights strictly reserved. Reproduction or issue to third parties in any form whatever is not permitted without written authority from the proprietor. Property of FCI. Copyright FCI.

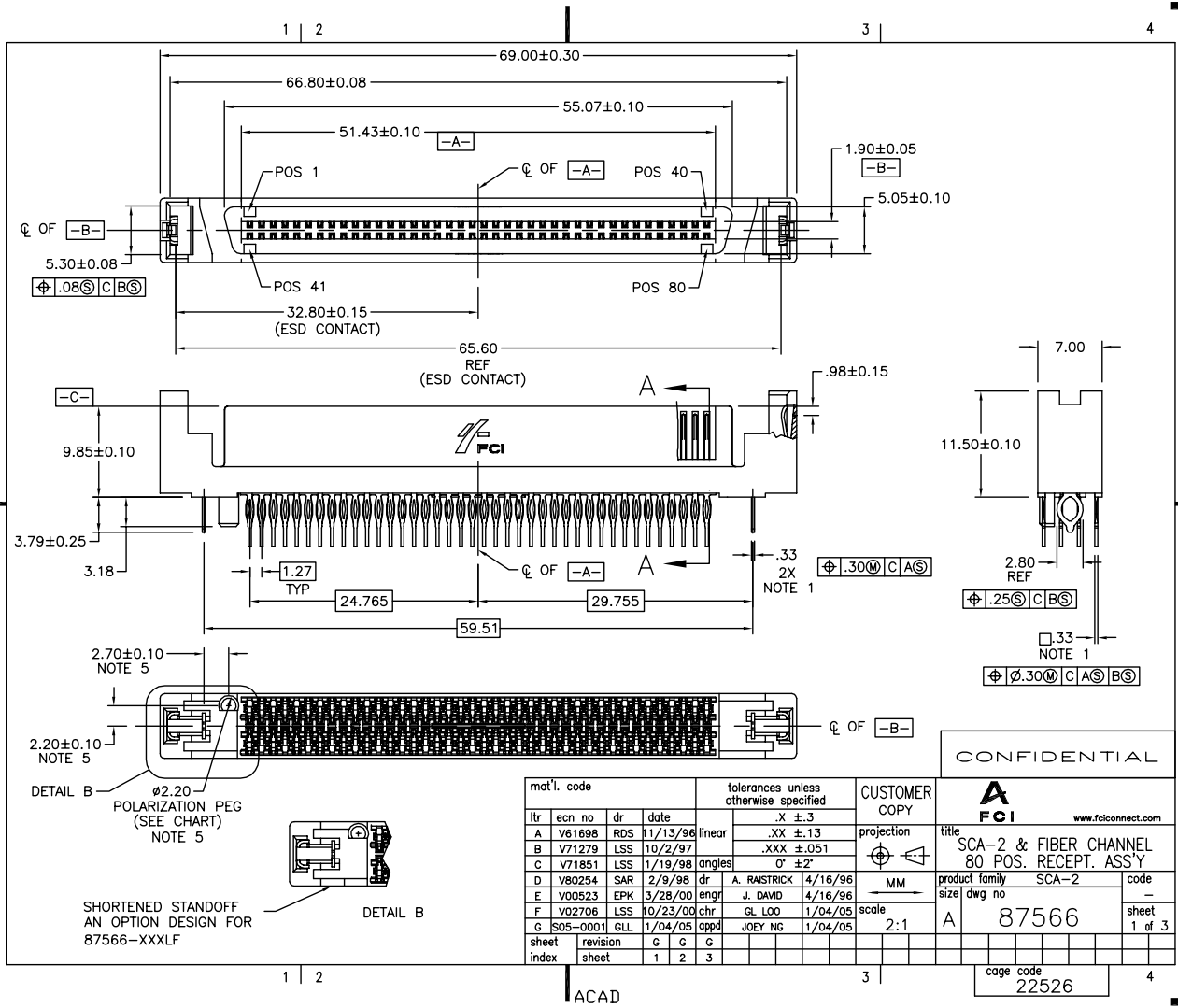

ltr	ecn no	dr	date	linear	tolerances unless otherwise specified
A	v81898	RDS	11/13/98		.X ±.3
B	v71279	LSS	10/2/97		.XX ±.13
C	v71851	LSS	1/19/98	angles	.XXX ±.051
D	v80254	SAR	2/9/98	dr	0° ±2°
E	v00523	EPK	3/28/00	engr	A. RAISTRICK 4/16/96
F	v02706	LSS	10/23/00	chr	J. DAVID 4/16/96
G	805-0001	GLL	1/04/05	appd	GL LOO 1/04/05
					JOEY NG 1/04/05

sheet index	revision	G	G	G
		1	2	3

CONFIDENTIAL	
 www.fciconnect.com	
title SCA-2 & FIBER CHANNEL 80 POS. RECEPT. ASSY	
product family SCA-2	code -
size A	dwg no 87566
	sheet 1 of 3
cage code 22526	

Tous droits strictement réservés. Reproduction ou communication à des tiers sans autorisation écrite de FCI est formellement interdite. Toute réimpression ou utilisation non autorisée sans la permission écrite du propriétaire. Propriété de FCI. Droits de reproduction FCI.



All rights strictly reserved. Reproduction or issue to third parties in any form or by any means without written authority from the proprietor. Property of FCI. Copyright FCI.

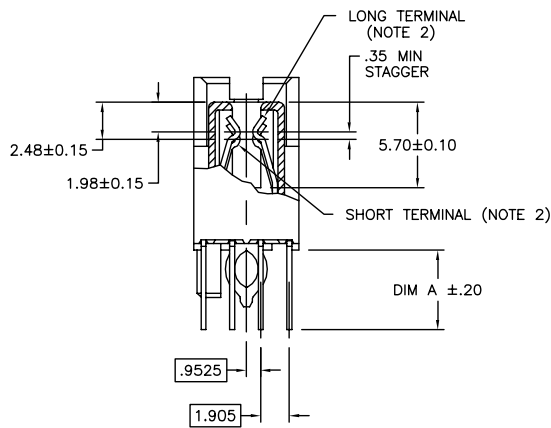

SECTION A-A

CONFIDENTIAL

mat'l. code		tolerances unless otherwise specified		CUSTOMER COPY		www.fciconnect.com		
ltr	ecn no	dr	date	linear	.X ±.3	projection	title	
G					.XX ±.13		SCA-2 & FIBER CHANNEL 80 POS. RECEPT. ASS'Y	
				angles	.XXX ±.051		product family	SCA-2
					0° ±2'	MM	size	code
				dr	A. RAISTRICK 4/16/96	scale	87566	sheet
				engr	J. DAVID 4/16/96	3:1	dwg no	2 of
				chr	GL LOO 1/04/05			
				appd	JOEY NG 1/04/05			
sheet index	revision sheet							

cage code 22526

ACAT

PDM: Rev:G

STATUS:Released

Printed: Mar 11, 2011

Tous droits strictement réservés. Reproduction ou communication e des tiers Interdite sous quelque forme que ce soit sans autorisation écrite du propriétaire. Propriete de c FCI. Droits de reproduction FCI.



All rights strictly reserved. Reproduction or issue to third parties in any form whatever is not permitted without written authority from the proprietor. Property of FCI. Copyright FCI.

PRODUCT NO.	"A" DIM	POLARIZATION PEG	PLATING	RECOMMENDED P.C. BOARD THICKNESS	PRODUCT NO.	PLATING	PRODUCT NO.	PLATING	PRODUCT NO.	PLATING
87566-001	3.79	YES	NOTE ④	2.36mm (0.093") AND 3.18mm (0.125")	87566-101	NOTE ⑥	87566-001LF	NOTE ⑧	87566-101LF	NOTE ⑦
-002	3.79	NO			-102		-002LF		-102LF	
-003	4.60	YES			-103		-003LF		-103LF	
87566-004	4.60	NO			87566-104		87566-004LF		87566-104LF	

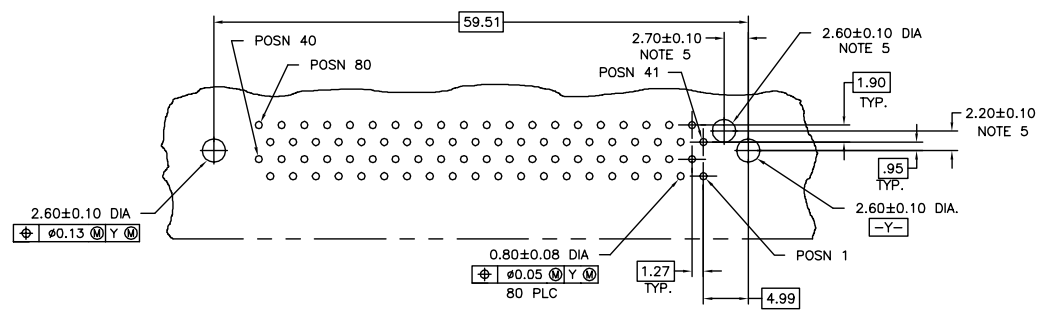

RECOMMENDED PC BOARD MOUNTING DIMENSIONS COMPONENT SIDE

NOTES :

- ① TRUE POSITION NOTES APPLY AT TERMINAL TIP.
- ② CONTACTS IN POSITIONS 2 THRU 35, 44 AND 47 THRU 74 ARE SHORT TERMINALS. CONTACTS IN POSITIONS 1, 36 THRU 43, 45, 46, AND 75 THRU 80 ARE LONG TERMINALS.
- ③ RAW MATERIALS: HOUSING: HTN, UL94V-0, COLOR: BLACK CONTACTS: PHOSPHOR-BRONZE
- ④ CONTACT PLATING: 30u" (0.76um) MIN. GXT PLATING OVER 50u" (1.27um) NICKLE UNDERPLATE IN CONTACT AREA. 20u" (0.5um) MIN. 60u" (1.5um) MAX TIN-LEAD PLATING OVER 50u" (1.27um) MIN. NICKLE UNDERPLATE IN P.C. BOARD LEG AREA. 50u" (1.27um) MIN. NICKLE UNDERPLATE OVER REMAINING AREA.
- ⑤ DIMENSIONS DO NOT APPLY TO CONNECTOR STYLES WITHOUT POLARIZATION PEG. (SEE CHART)
- ⑥ CONTACT PLATING: 30u" (0.76um) MIN GOLD PLATING OVER 50u" (1.27um) NICKLE UNDERPLATE IN CONTACT AREA. 20u" (0.5um) MIN-60u" (1.5um) MAX TIN-LEAD PLATING OVER 50u" (1.27um) MIN. NICKLE UNDERPLATE IN P.C. BOARD LEG AREA. 50u" (1.27um) MIN. NICKLE UNDERPLATE OVER REMAINING AREA.
- ⑦ CONTACT PLATING: 30u" (0.76um) GOLD PLATING OVER 50u" (1.27um) NICKLE UNDERPLATE IN CONTACT AREA. 20u" (0.5um) - 60u" (1.5um) TIN PLATING OVER 50u" (1.27um) - 100u" (2.54um) NICKEL UNDERPLATE IN P.C. BOARD LEG AREA. 50u" (1.27um) NICKEL UNDERPLATE OVER REMAINING AREA.
- ⑧ CONTACT PLATING: 30u" (0.76um) GXT PLATING OVER 50u" (1.27um) NICKLE UNDERPLATE IN CONTACT AREA. 20u" (0.5um) - 60u" (1.5um) TIN PLATING OVER 50u" (1.27um) - 100u" (2.54um) NICKEL UNDERPLATE IN P.C. BOARD LEG AREA. 50u" (1.27um) NICKEL UNDERPLATE OVER REMAINING AREA.
- ⑨ THE HOUSING WILL WITHSTAND EXPOSURE TO 260°C PEAK TEMPERATURE FOR 10 SECONDS IN A CONVECTION, INFRA RED VAPOR PHASE REFLOW OVEN.
- ⑩ THIS PRODUCT MEETS EUROPEAN UNION DIRECTIVES AND OTHER COUNTRY REGULATIONS AS DESCRIBED IN GS-22-008.

CONFIDENTIAL

mat'l. code		tolerances unless otherwise specified		CUSTOMER COPY		www.fciconnect.com	
ltr	ecn no	dr	date	linear	.X ±.3	projection	title
g				angles	.XX ±.13		SCA-2 & FIBER CHANNEL 80 POS. RECEPT. ASSY
					.XXX ±.051		product family
				dr	0 ±.2	MM	code
				enrg	A. RAISTRICK 4/16/96	scale	87566
				chr	J. DAVID 4/16/96	3:1	sheet
				appd	GL LOO 1/04/05		3 of 3
					JOEY NG 1/04/05		
sheet index	revision sheet						

1 | 2

3

4

ACAD

cage code 22526