

Phase Control Thyristor

$$V_{RRM} = 800-1600 \text{ V}$$

$$I_{T(RMS)} = 75 \text{ A}$$

$$I_{T(AV)M} = 48 \text{ A}$$

V_{RSM} V_{DSM} V	V_{RRM} V_{DRM} V	Type
900	800	CS 45-08 io1
1300	1200	CS 45-12 io1
1700	1600	CS 45-16 io1 CS 45-16 io1R

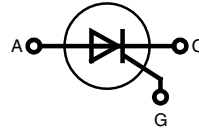
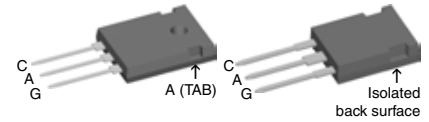
TO-247 AD
Version io1ISOPLUS247™
Version io1R

A = Anode, C = Cathode, G = Gate

Symbol	Conditions	Maximum Ratings
I_{TRMS}	$T_{VJ} = T_{VJM}$	75 A
$I_{T(AV)M}$	$T_C = 75^\circ\text{C}$, 180° sine	48 A
I_{TSM}	$T_{VJ} = 45^\circ\text{C}$	$t = 10 \text{ ms}$ (50 Hz), sine 520 A
	$V_R = 0 \text{ V}$	$t = 8.3 \text{ ms}$ (60 Hz), sine 560 A
	$T_{VJ} = T_{VJM}$	$t = 10 \text{ ms}$ (50 Hz), sine 460 A
	$V_R = 0$	$t = 8.3 \text{ ms}$ (60 Hz), sine 500 A
I^2t	$T_{VJ} = 45^\circ\text{C}$	$t = 10 \text{ ms}$ (50 Hz), sine 1350 A ² s
	$V_R = 0 \text{ V}$	$t = 8.3 \text{ ms}$ (60 Hz), sine 1300 A ² s
	$T_{VJ} = T_{VJM}$	$t = 10 \text{ ms}$ (50 Hz), sine 1050 A ² s
	$V_R = 0 \text{ V}$	$t = 8.3 \text{ ms}$ (60 Hz), sine 1030 A ² s
$(di/dt)_{cr}$	$T_{VJ} = T_{VJM}$ $f = 50 \text{ Hz}$; $t_p = 200 \mu\text{s}$	repetitive, $I_T = 40 \text{ A}$ 150 A/ μs
	$V_D = \frac{2}{3} V_{DRM}$ $I_G = 0.3 \text{ A}$ $di_G/dt = 0.3 \text{ A}/\mu\text{s}$	non repetitive, $I_T = I_{T(AV)M}$ 500 A/ μs
$(dv/dt)_{cr}$	$T_{VJ} = T_{VJM}$; $V_D = \frac{2}{3} V_{DRM}$ $R_{GK} = \infty$; method 1 (linear voltage rise)	1000 V/ μs
P_{GM}	$T_{VJ} = T_{VJM}$; $t_p = 30 \mu\text{s}$	10 W
P_{GAV}	$I_T = I_{T(AV)M}$; $t_p = 300 \mu\text{s}$	5 W
V_{RGM}		0.5 W
T_{VJ}		10 V
T_{VJM}		-40 ... +140 °C
T_{stg}		140 °C
M_d	Version io1: mounting torque M3	-40 ... 125 °C
F_C	Version io1R: mounting force with clip	0.8...1.2 Nm
V_{ISOL}^*	50/60 Hz, RMS, $t = 1 \text{ minute}$, leads-to-tab	20...120 N
Weight	typ.	2500 V~
		6 g

* Version io1R only

Data according to IEC 60747

Features

- Thyristor for line frequency
- International standard package JEDEC TO-247
- Planar passivated chip
- Long-term stability of blocking currents and voltages
- Version AR isolated and UL registered E153432
- Epoxy meets UL 94V-0

Applications

- Motor control
- Power converter
- AC power controller
- Switch-mode and resonant mode power supplies
- Light and temperature control

Advantages

- Easy to mount with 1 screw (isolated mounting screw hole)
- Space and weight savings
- Simple mounting
- Improved temperature and power cycling

Symbol	Conditions	Characteristic Values	
		min.	max.
I_R, I_D	$V_R = V_{RRM}; V_D = V_{DRM}; T_{VJ} = T_{VJM}$		5 mA
V_T	$I_T = 80 \text{ A}; T_{VJ} = 25^\circ\text{C}$		1.64 V
V_{TO}	For power-loss calculations only		0.85 V
r_T	$T_{VJ} = 125^\circ\text{C}$		11 mΩ
V_{GT}	$V_D = 6 \text{ V}; T_{VJ} = 25^\circ\text{C}$		1.5 V
	$T_{VJ} = -40^\circ\text{C}$		1.6 V
I_{GT}	$V_D = 6 \text{ V}; T_{VJ} = 25^\circ\text{C}$		100 mA
	$T_{VJ} = -40^\circ\text{C}$		200 mA
V_{GD}	$V_D = 2/3 V_{DRM}; T_{VJ} = T_{VJM}$		0.2 V
I_{GD}			10 mA
I_L	$t_p = 10 \mu\text{s}; T_{VJ} = 25^\circ\text{C}$ $I_G = 0.3 \text{ A}; di_G/dt = 0.3 \text{ A}/\mu\text{s}$		150 mA
I_H	$V_D = 6 \text{ V}; R_{GK} = \infty; T_{VJ} = 25^\circ\text{C}$		100 mA
t_{gd}	$V_D = 1/2 V_{DRM}; T_{VJ} = 25^\circ\text{C}$ $I_G = 0.3 \text{ A}; di_G/dt = 0.3 \text{ A}/\mu\text{s}$		2 μs
R_{thJC}	DC current		0.62 K/W
R_{thJH}	DC current		0.82 K/W
a	Max. acceleration; 50 Hz		50 m/s ²

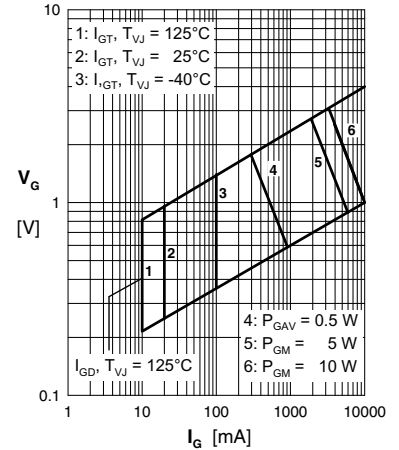

Fig. 1 Gate trigger range

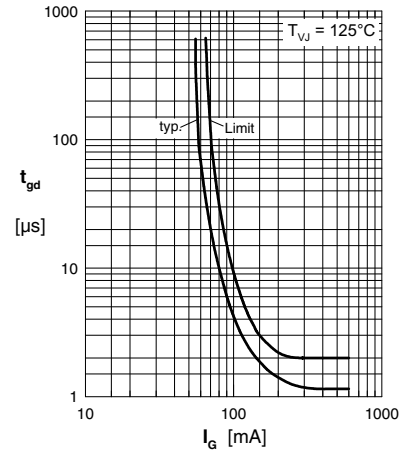
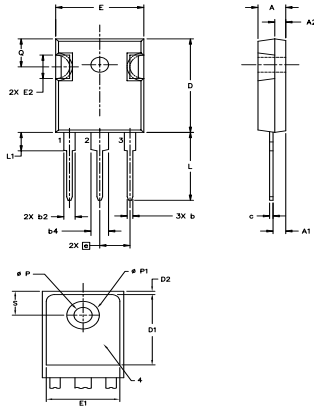

Fig. 2 Gate controlled delay time t_{gd}

TO-247 AD



Dim.	Millimeter		Inches	
	Min.	Max.	Min.	Max.
A	19.81	20.32	0.780	0.800
B	20.80	21.46	0.819	0.845
C	15.75	16.26	0.610	0.640
D	3.55	3.65	0.140	0.144
E	4.32	5.49	0.170	0.216
F	5.40	6.20	0.212	0.244
G	1.65	2.13	0.065	0.084
H	-	4.50	-	0.177
J	1.00	1.40	0.040	0.055
K	10.80	11.00	0.426	0.433
L	4.70	5.30	0.185	0.209
M	0.40	0.80	0.016	0.031
N	1.50	2.49	0.087	0.102

Dimensions (1 mm = 0.0394")

ISOPLUS 247™

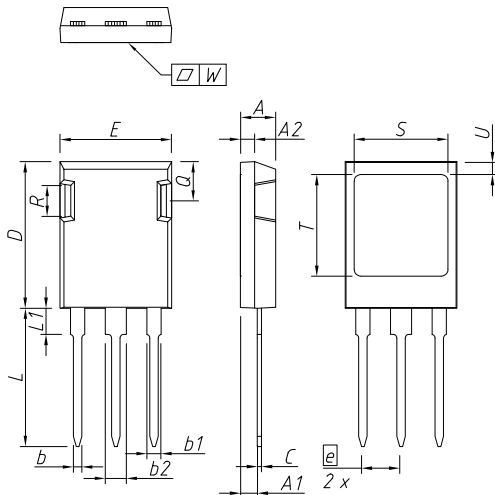

DIM.	MILLIMETER		INCHES	
	MIN	MAX	MIN	MAX
A	4,83	5,21	0,190	0,205
A1	2,29	2,54	0,090	0,100
A2	1,91	2,16	0,075	0,085
b	1,14	1,40	0,045	0,055
b1	1,91	2,15	0,075	0,085
b2	2,92	3,20	0,115	0,126
C	0,61	0,83	0,024	0,033
D	20,80	21,34	0,819	0,840
E	15,75	16,13	0,620	0,635
e	5,45 BSC		0,215 BSC	
L	19,81	20,60	0,780	0,811
L1	3,81	4,38	0,150	0,172
Q	5,59	6,20	0,220	0,244
R	4,32	4,85	0,170	0,191
S	13,21	13,72	0,520	0,540
T	15,75	16,26	0,620	0,640
U	1,65	2,03	0,065	0,080
W		0,10		0,004

Die konvexe Form des Substrates ist typ. < 0.04 mm über der Kunststoffoberfläche der Bauteilunterseite.
The convex bow of substrate is typ. < 0.04 mm over plastic surface level of device bottom side.

Die Gehäuseabmessungen entsprechen dem Typ TO-247 AD gemäß JEDEC außer Schraubloch und L_{max} .
This drawing will meet all dimensions requirement of JEDEC outline TO-247 AD except screw hole and except L_{max} .

IXYS reserves the right to change limits, test conditions and dimensions.

20100203a

© 2010 IXYS All rights reserved

2 - 3

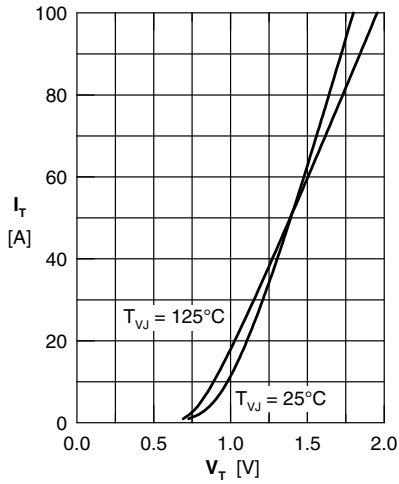

Fig. 3 Forward characteristics

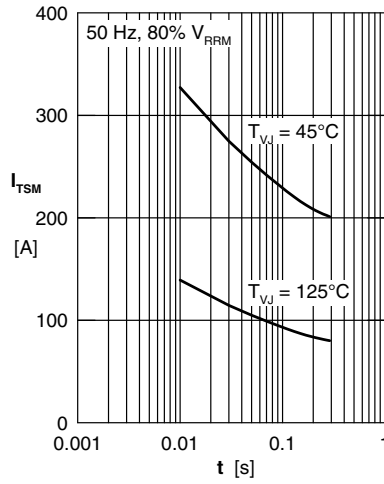

Fig. 4 Surge overload current
I_{TSM}: crest value, t: duration

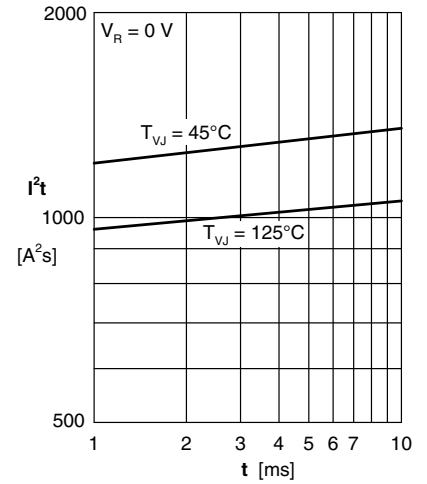

Fig. 5 I²t versus time (1-10 s)

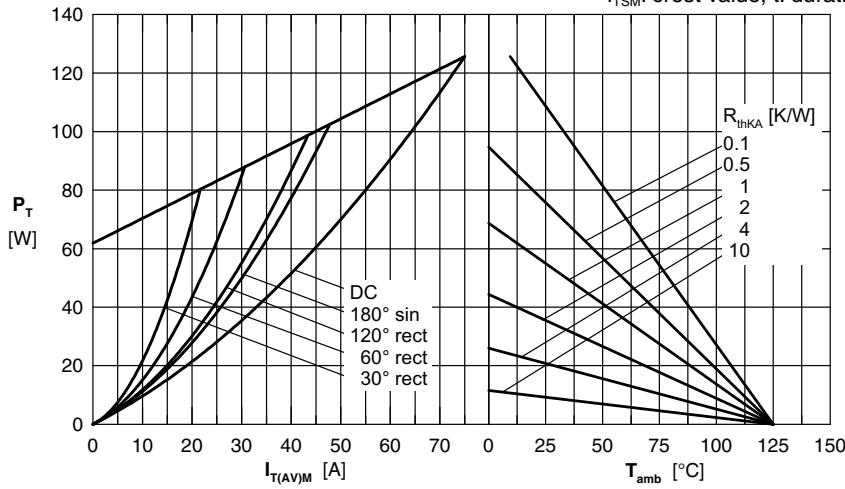

Fig. 6 Power dissipation versus forward current and ambient temperature

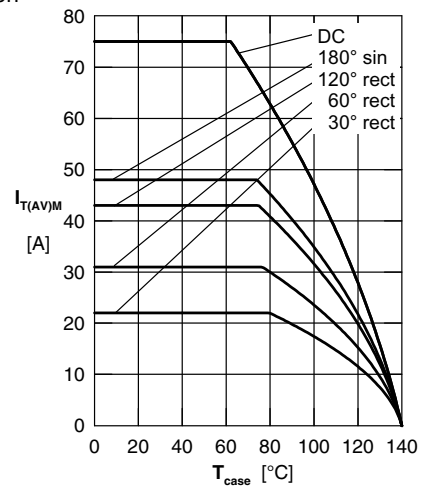

Fig. 7 Max. forward current at case temperature

R_{thJC} for various conduction angles d:

d	R _{thJC} (K/W)
DC	0.62
180°	0.71
120°	0.748
60°	0.793
30°	0.817

Constants for Z_{thJC} calculation:

i	R _{thi} (K/W)	t _i (s)
1	0.206	0.013
2	0.362	0.118
3	0.052	1.488

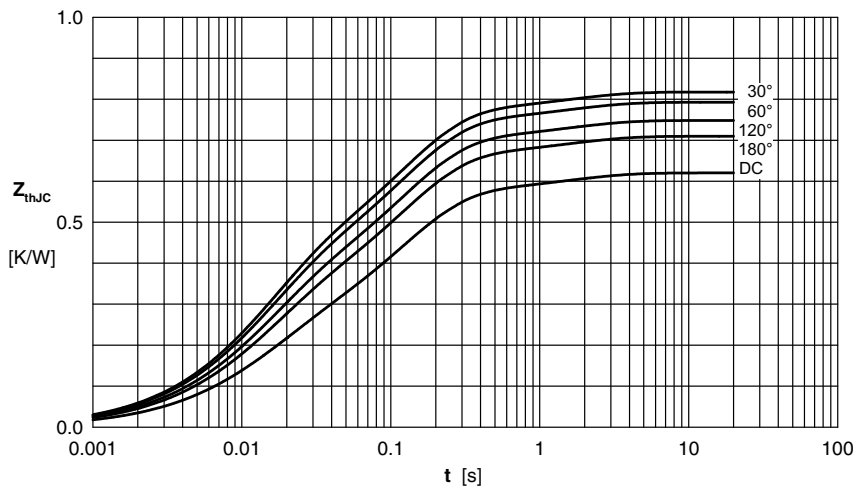

Fig. 8 Transient thermal impedance junction to case