



DM/F240-PCIU and DM/F300-PCIU Fax Boards

The DM/F240-PCIU and DM/F300-PCIU boards are high-density fax resource boards, each offering a full span of either 24 or 30 ports of feature-rich fax capabilities on a single board in a single Universal PCI slot. These boards make it easy for developers to add fax technology to their existing computer telephony (CT) and media server applications.



High-Density Fax Resource Boards

The DM/F240-PCIU and DM/F300-PCIU boards give fax-intensive applications robust processing power and flexibility. Users can take advantage of a span of 24 or 30 ports of feature-rich fax capabilities on a single board, deploying fewer boards per chassis and, ultimately, fewer and smaller chassis overall. This lowers the cost of ownership and enables more end users to deploy computer telephony (CT) applications. Up to eight DMF series fax boards (up to 196 or 240 ports of fax) can be combined in a single chassis.

Intel in
Communications

Features and Benefits

High density — The DM/F240-PCIU and DM/F300-PCIU boards provide 24 or 30 send and receive intelligent fax ports, in a single Universal PCI slot. This high density lowers per-slot costs and, by extension, overall system costs.

Short transmission time — Fast 14.4 KB/s fax transmission, both sending and receiving, concurrently on all channels, helps shorten transmission time and save on phone costs.

Worldwide compatibility — Compatibility with T.30 protocol and modifications helps ensure high compatibility with fax devices worldwide.

Fast throughput — On-board and on-the-fly MH, MR, and MMR compression mean fast throughput, maximizing the number of pages a user can fax per minute and minimizing the amount of time spent on the phone.

Operating system choice — These high-density fax boards support the Microsoft® Windows NT®, Windows® 2000, Windows XP®, and RedHat® Linux® operating systems.

Upgradable — These digital signal processor (DSP)-based boards provide maximum flexibility and future firmware upgradability.

Easy Multi-Media Integration — R4 API enables developers to easily integrate the fax resource board into multimedia applications.

Choice of Interfaces — Support for SCbus and H.100* compliant network interface products provides maximum flexibility.

Choice of Form Factors — Support for both PCI and CompactPCI* ensures maximum configurability with any system requirement or configuration

Color Fax Support — Color fax support ensures compatibility with state-of-the-art fax features and increased compatibility with newest multi-function fax devices.

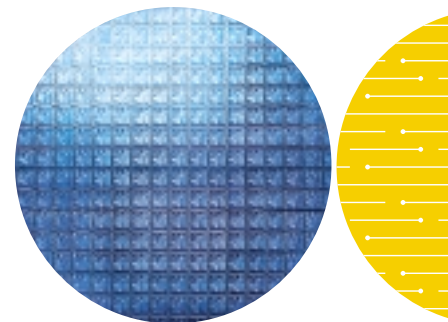

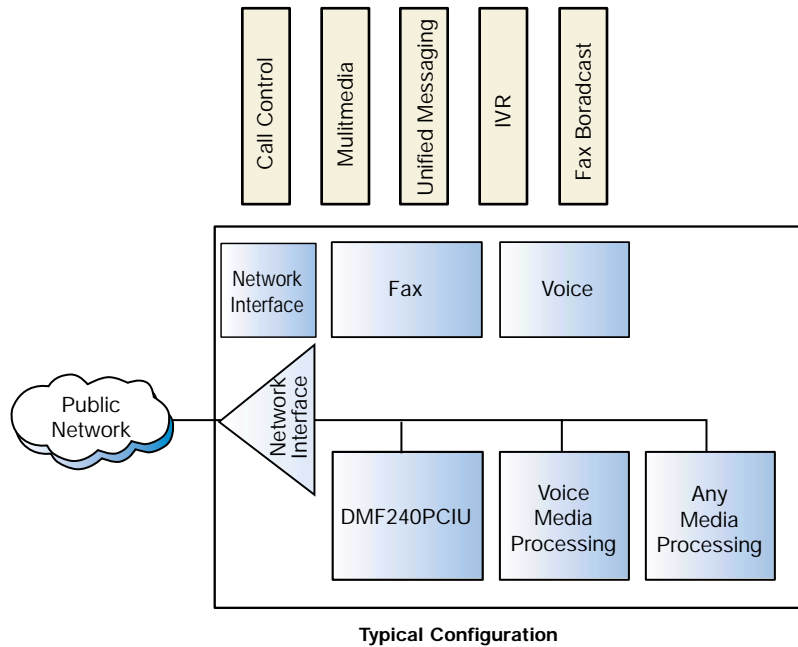

The DM/F240-PCIU and DM/F300-PCIU boards offer a rich set of full fax features and support state-of-the-art digital signal processing (DSP) technology and industry-standard Universal PCI and CT Bus technologies. Combined with other boards such as network interfaces and media processing boards, the DM/F240-PCIU and DM/F300-PCIU boards are positioned to fulfill the needs and demands of the fax server and unified messaging market segments.

Configurations

Use the DM/F240-PCIU and DM/F300-PCIU to add fax processing to your systems using network interfaces and media (e.g., voice) processing boards. Build sophisticated, converged communications systems to which you can easily add capabilities like fax-on-demand, fax broadcast, and unified messaging services.

The DM/F240-PCIU and DM/F300-PCIU boards share a common hardware and firmware architecture with the other CT Bus boards for maximum flexibility and scalability. You can add features and grow your systems while protecting your investment in hardware

and application code. With only minimum modifications, applications can be easily ported to lower- or higher-line-density platforms. The DM/F240-PCIU and DM/F300-PCIU boards install in any Universal PCI-based personal computer or server and compatible computers (PC platforms based on the Intel® Pentium® processor). The DM/F240-PCIU and DM/F300-PCIU boards provide everything required for adding high-density fax solutions to your media servers from one to eight PRI trunks. The maximum number of lines that can be supported depends on the application, the amount of disk I/O required, the host computer CPU, and the power supply.

The DM/F240-PCIU and DM/F300-PCIU boards can operate within a mixed chassis containing PCIU products from Intel. The boards' forward-looking design incorporates the H.100 connector to simplify connection to next-generation CT Bus products. They can also connect to existing SCbus products through the use of an optional CT Bus/SCbus adapter. The adapter provides both SCbus and H.100 physical connectors required to link the DM/F240-PCIU and DM/F300-PCIU boards to current SCbus products.

Applications

- **Fax broadcast** — A fax broadcast system, which sends out numerous fax messages such as press releases in one easy operation, is an efficient way to save money on communications costs.
- **Unified messaging** — With high densities that allow for maximum lines in a minimal footprint, these boards are the ideal choice for adding fax capabilities to open, modular unified messaging solutions.
- **Fax server** — Using these high-density boards in a fax server application makes it simple and affordable to add fax to the communications infrastructure.
- **Fax on demand** — It's easy to reach out to customers by giving them easy telephone access to faxed information with no operator involvement. This is an ideal way to stretch a company's communications budget.

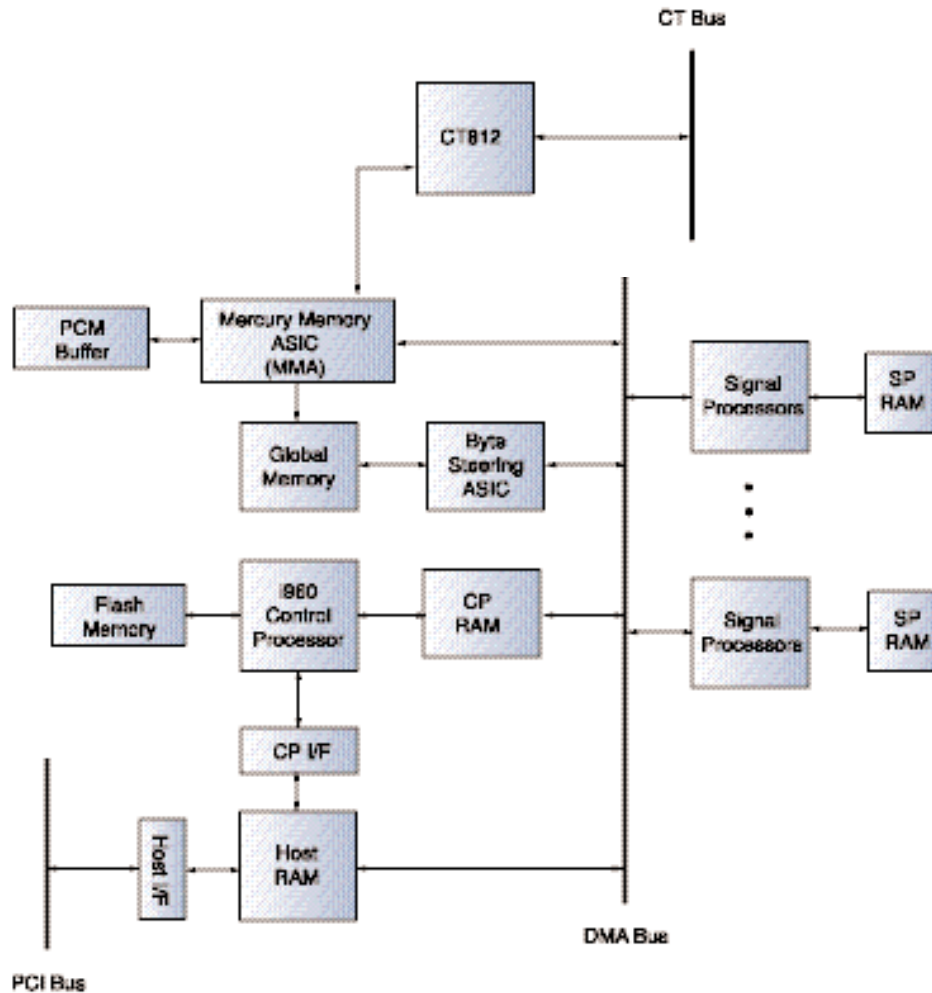

Functional Diagram

Software Support

The DM/F240-PCIU and DM/F300-PCIU fax boards support the Microsoft Windows NT 4.0, Windows 2000, Windows XP, and RedHat Linux operating systems.

The DM/F240-PCIU and DM/F300-PCIU fax boards include the R4 API for fax, which help to ensure a clear migration path and seamless integration into existing applications, protecting the developer's investment in code.

As an alternative, developers can choose the DM/F240-1T1-PCIU and DM/F300-1E1-PCIU fax-only boards with an on-board network interface, or the Intel® Dialogic® CPI/2400-1T1-PCIU and CPI/3000-1E1-PCIU fax boards, which can be programmed through the legacy GammaLink API.

The fax-only resource products are also available with a CompactPCI form factor with the DM/F240-CPCI and DM/F300-CPCI products.

Functional Description

The DM/F240-PCIU and DM/F300-PCIU fax boards support the Microsoft Windows NT 4.0, Windows 2000, Windows XP, and RedHat Linux operating systems.

The DM/F240-PCIU and DM/F300-PCIU fax boards include the R4 API for fax, which helps to ensure a clear migration path and seamless integration into existing applications, protecting the developer's investment in code.

As an alternative, developers can choose the DM/F240-1T1-PCIU and DM/F300-1E1-PCIU fax-only boards with an on-board network interface, or the Intel® Dialogic® CPI/2400-1T1-PCIU and CPI/3000-1E1-PCIU fax boards, which can be programmed through the legacy GammaLink API.

The fax-only resource products are also available with a CompactPCI form factor with the DM/F240-CPCI and DM/F300-CPCI products.

Technical Specifications**

Hardware

Form factor	Universal PCI (5 VDC or 3.3 VDC)
Size	Full size
Telephony bus	CT Bus, H.100 (fax resources are fully exportable.)
Power requirements	+5 VDC (19 watt) +12 VDC (N/A) -12 VDC (N/A) +3.3 VDC (N/A)
Cooling (per board)	50°C 2.3 CFM 40°C 1.5 CFM 30°C 1.1 CFM
Operating temperature	0°C to +50°C
Storage temperature	-20°C to +70°C
Humidity	8 to 80% non-condensing

Software

Operating system	Windows NT 4.0 Windows 2000 Windows XP RedHat Linux
API	R4 (fax)

Fax Features

ITU	T.30, T.4, T.6 V.17, V29, V27ter, V.21
Speed	14.4 Kbps with automatic fallback, send and receive, concurrently on all channels
TIFF	Single page, multi-page
Compression	MH (ITU T.4, 1D) MR (ITU T.4 2D) MMR (ITU T.6) On-board and on-the-fly
ASCII-to-TIFF	On-board and on-the-fly
Page headers	Generated on-board, on-the-fly
ECM	Supported
Width	A4, A3, B4
Polling	Normal and turnaround
Resolution	Standard (100 x 200) Fine (200 x 200) Superfine (200 x 400)
JPEG/JBIG	Color fax and grayscale fax pass through feature

Safety and EMC Certifications

FCC	Approved
C-UL	Approved
UL	Approved
CE	Approved

Hardware System Requirements

- SR 5.1.1 call-out minimum for DM3 is 200MHZ with 128M (2 or fewer boards) or 512M (3 or more boards)
- Windows NT 4.0, Windows 2000, Windows XP, or RedHat Linux operating system

To learn more, visit our site on the World Wide Web at <http://www.intel.com>.

1515 Route Ten
Parsippany, NJ 07054
Phone: 1-973-993-3000

INFORMATION IN THIS DOCUMENT IS PROVIDED IN CONNECTION WITH INTEL® PRODUCTS. NO LICENSE, EXPRESS OR IMPLIED, BY ESTOPPEL OR OTHERWISE, TO ANY INTELLECTUAL PROPERTY RIGHTS IS GRANTED BY THIS DOCUMENT. EXCEPT AS PROVIDED IN INTEL'S TERMS AND CONDITIONS OF SALE FOR SUCH PRODUCTS, INTEL ASSUMES NO LIABILITY WHATSOEVER, AND INTEL DISCLAIMS ANY EXPRESS OR IMPLIED WARRANTY, RELATING TO SALE AND/OR USE OF INTEL PRODUCTS INCLUDING LIABILITY OR WARRANTIES RELATING TO FITNESS FOR A PARTICULAR PURPOSE, MERCHANTABILITY, OR INFRINGEMENT OF ANY PATENT, COPYRIGHT OR OTHER INTELLECTUAL PROPERTY RIGHT. Intel products are not intended for use in medical, life saving, life sustaining applications.

Intel may make changes to specifications and product descriptions at any time, without notice.

¹Configurable to meet country-specific PTT requirements. Actual specification may vary from country to country for approved products.

Intel, Intel Dialogic, Intel NetStructure, Pentium, and the Intel logo are trademarks or registered trademarks of Intel Corporation or its subsidiaries in the United States and other countries.

*Other names and brands may be claimed as the property of others.

