

IrDA Low Power Option / Compact Feature Type

GP2W0110YP0F / GP2W0114YP0F

Technical Data

GP2W0114YP0F is the TOP View version  
of GP2W0110YP0F



**1. Features**

- ⇒ IrDA Low Power Option Compatibility for Telecommunication and Mobile terminals.
- ⇒ Industry Low Volume Package Design for a Low Power Transceiver  
( $W\ 7.6\ x\ D\ 2.65\ x\ H\ 2.0\ mm$ ,  $40.28\ mm^3$ )
- ⇒ Low Power Consumption by Built-in Shut-Down Mode (*typ.*  $0.2\ \mu A$ )
- ⇒ Low & Wide Range Operating Voltage ( $V_{dd} = 2.0V \sim 3.6V$ ,  $V_{LEDA} = 2.0 - 6.0V$ .)
- ⇒ Soldering Reflow Capable
- ⇒ SMD Lead-less Packages Enable both **Vertical Mount and Horizontal Mount** to PCBs
- ⇒ Replaces GP2W0102YP / GP2W0104YP / GP2W0106YP.
- ⇒ **Added features** include tri-state output and split-voltage supply capability.
- ⇒ **Fully compatible with Agilent / Avago HSDL 3201.**

**<Applications>**

*Telecommunication Products*

- Mobile Phones
- Pagers
- Smart Phones

*Mobile Products*

- PDAs
- Electric Wallets
- Mini-Notebook PCs

*Imaging Products*

- Portable Printers
- Portable Text Scanners

**2. Description**

The SHARP GP2W0110YP0F is a low-power, short-range infrared transceiver module. It meets the Mobile Communication **low power option** within the IrDA Specifications for 20-cm communication range. This unit provides the interface between logic and IR signals for through-air, serial, half-duplex IR wireless data links at rates up to 115 kbit/s, and is designed to satisfy the IrDA physical layer (PHY) specifications.

The SHARP GP2W0110YP0F infrared transceiver module contains a high speed, high efficiency, low power consumption AlGaAs LED, silicon PIN photodiode, and the low power driven bipolar integrated circuit. The IC contains a LED driver circuit and a receiver that provides the RX output supporting 2.4k to 115.2 kbit/s IrDA signals, meeting the IrDA low power option communication standard (link distance of 0.2m with low powered devices and 0.3m link with standard devices.)

The GP2W0110YP0F includes a constant-current source in the LED driver circuit that eliminates the need for an external current limiting resistor in the LED circuit.

The low power option specification is most suitable for telecommunication products and mobile terminals, such as cellular phones, paging devices, and PDA-cellular combined multimedia devices. The transceiver module provides capability for a wireless

data link for cellular phones and pagers, PDAs, or any other IrDA application already introduced to the market place.

This transceiver module receiver electronics can operate at 2.0V through 3.6V without any performance degradation. The split-voltage supply allows for the LED voltage to come from a separate supply. An example is cell phones where the LED may operate from the battery and the receiver and logic section is supplied from a lower voltage regulated supply.

This provides manufacturers with the advantage of an energy saving design in any application field, with alternatives for supply voltage and flexibility for other components. The GP2W0110YP0F transceiver module has a built-in 0.1- $\mu A$ -shutdown mode for those applications that are very conscious about current consumption. Additionally, the GP2W0110YP0F has a tri-state output, which allows its use in applications where one port connection may be connected to more than one device.

The shield is appropriate in applications where Electro-Magnetic Interference (EMI) is a concern. Infrared energy is immune to EMI, however the receiving PIN photodiode is somewhat sensitive to EMI. This is the case in all IR communication devices.

### 3. Package

The dimensional drawing and all packaging information is available on-line at [www.sharpsma.com](http://www.sharpsma.com). Select Products/Optoelectronics/IrDA. All available models will be shown and specifications and drawings provided in the available documents. These documents will have the most up-to-date information.

### 4. Absolute Maximum Ratings

Parameter	Symbol	Min.	Max.	Unit	Conditions
Supply Voltage	$V_{DD}$	0	6.0	V	
LED Supply Voltage	$V_{LEDA}$	0	7.0	V	
Operating Temperature	$T_{OP}$	-40	+85	°C	
Storage Temperature	$T_{ST}$	-40	+85	°C	
Soldering Temperature	$T_{SOL}$		230	°C	See Section 10 for soldering reflow profile
Peak Forward LED Current	$I_{FM}$		60	mA	

### 5. Recommended Operating Conditions

Parameter	Symbol	Min.	Max.	Unit	Conditions
Operating Temperature	$T_{OP}$	-25	+85	°C	typical 25° C
Supply Voltage	$V_{DD}$	2.0	3.6	V	
LED Supply Voltage	$V_{LEDA}$	2.0	6.0	V	
Logic High Shut-Down Terminal Input Voltage	$V_{IHSD}$	$V_{DD} \times 0.67$	$V_{DD}$	V	Shutdown mode
Logic Low Shut-Down Terminal Input Voltage	$V_{ILSD}$	0.0	$V_{DD} \times 0.1$	V	Normal mode
Logic High Transmitter Input Voltage (TXD)	$V_{IHTXD}$	$V_{DD} \times 0.75$	$V_{DD}$	V	LED on
Logic Low Transmitter Input Voltage (TXD)	$V_{ILTXD}$	0.0	$V_{DD} \times 0.2$	V	LED off
Logic High Receiver Input Irradiance	$E_{IH}$	9.0		$\mu\text{W}/\text{cm}^2$	Bit Rate = 2.4k ~ 115 kb/s (in-band signals) <sup>*1</sup>
Receiver Signal Rate	BR	2.4	115.2	kb/s	

1. An in-band optical signal is a pulse/sequence where the peak wavelength,  $\lambda_p$ , is defined as  $850 \text{ nm} \leq \lambda_p \leq 900 \text{ nm}$ , and the pulse characteristics are compliant with the IrDA Serial Infrared Physical Layer Link Specifications.

**6. Electrical and Optical Specifications**

Specifications hold over the Recommended Operating Conditions, unless otherwise noted. All typical values are at 25°C and V<sub>DD</sub> = 2.0 to 3.6V, unless otherwise noted. Refer to specifications for complete details and conditions.

Parameter	Symbol	Min.	Typ.	Max.	Unit	Conditions
Maximum Reception Distance	L	≥ 0.2	-	-	m	2θ <sub>1/2</sub> ≤ 15°, I <sub>E</sub> = 3.6 mW/sr
High Level Output Voltage	V <sub>OHRXD</sub>	V <sub>DD</sub> -0.4	-	-	V	I <sub>OH</sub> = 20 μA
Low Level Output Voltage	V <sub>OLRXD</sub>	-	-	0.45	V	I <sub>OL</sub> = 20 μA
Viewing Angle	2θ	30	-	-	degrees	
Low Level Pulse Width	t <sub>w</sub>	1.0	-	3.0	μsec	BR = 115.2 kb/s, 2θ <sub>1/2</sub> ≤ 15°
Current Consumption	I <sub>DD</sub>	-	90	120	μA	With no input signal, SD = 0V, Output Terminal OPEN
	I <sub>DD-S</sub>	-	0.01	2.0	μA	Shutdown Mode, no input signal, V <sub>IHSD</sub> = V <sub>DD</sub> - 0.5V, Output Terminal OPEN, Topr = 25° C, V <sub>DD</sub> = 3.3V.
Rise Time	t <sub>r</sub>	-	-	0.4	μsec	see below
Fall Time	t <sub>f</sub>	-	-	0.4	μsec	see below
Latency	t <sub>TAT</sub>	-	25	300	μsec	
Receiver wakeup time	t <sub>sdw</sub>	-	-	200	μsec	
Radiant Intensity	I <sub>E</sub>	3.6	-	25	mW/sr	2θ <sub>1/2</sub> ≤ 15°, BR = 115.2 kbit/s,
Peak Emission Wavelength	λ <sub>p</sub>	850	870	900	nm	V <sub>LEDA</sub> = 3.3V, V <sub>IHTXD</sub> = 2.8V, notes 4, 5, 6
Peak LED Current	I <sub>LED</sub>	-	32	-	mA	
Shutdown input current	I <sub>ISD</sub>	-0.02	0	+0.02	μA	Topr = 25° C, V <sub>DD</sub> = 3.3V.
TXD high level input current	I <sub>IHTXD</sub>	-	-	50	μA	
TXD low level input current	I <sub>IITXD</sub>	-	-	0.2	μA	

I<sub>OL</sub>: Current goes into IC while RXD is ON state (Low Level Output)

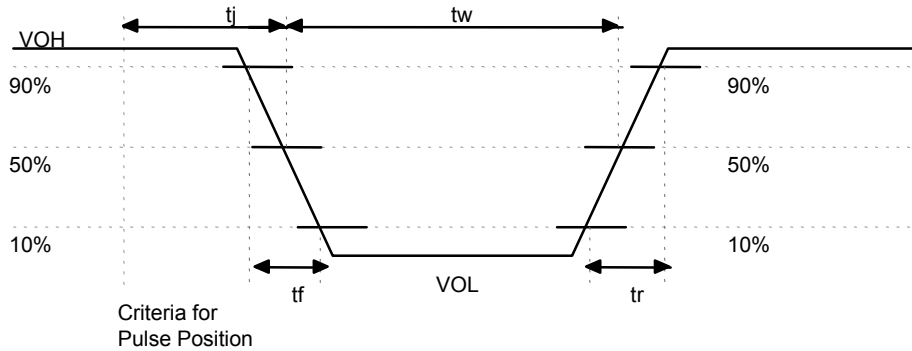

GP2W0110YP Infrared Transceiver Module Output Waveform

**7. Truth Table**

SD	TXD	LED	Receiver	TR1	TR2	RXD
Low	High	On	Don't Care	-	-	Not valid
	Low	Off	IrDA Signal	Off	On	Low
			No signal	On	Off	High
High	Don't care	Off	Don't care	Off	Off	Pull-up

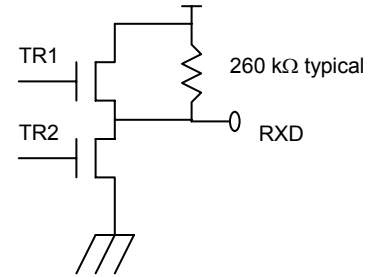

**8. Pinouts**

PIN #	Description	Symbol
1	No Connection	NC
2	No Connection	NC
3	Supply Voltage	VDD
4	Ground	GND
5	Shutdown	SD
6	Receiver Data Output	RXD
7	Transmitter Data Input	TXD
8	LED Anode	LEDA

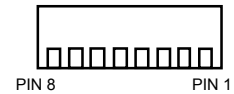
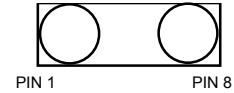

**9. Application Electrical Design Hints**

The only external component needed for the GP2W0110YP0F is a capacitor for filtering any power supply noise. See Section 11 for technical reference data in optical / electrical characteristics.

**9-1 Application Circuit and External Passives**

Following application circuit is recommended.

Component	Recommended Value
CX	10 μF / 6.3V (NOTE)

(NOTE)

Suitable CX value should be adjusted in accordance with the noise level and the power supply frequency.

$V_{LEDA}$  may be connected to  $V_{DD}$  or driven separately from a different voltage source that is within the allowed range. The recommended operating voltage range for  $V_{DD}$  is 2.0 to 3.6V, and the operating range for  $V_{LEDA}$  is 2.0 to 6.0V.

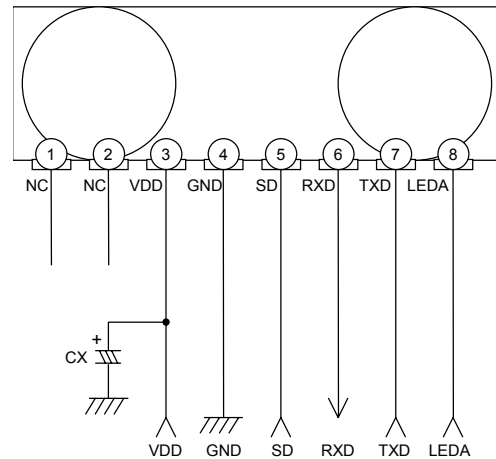

An example of the split voltage source design is shown below. In the drawing, the VDD pin is used to provide power to the receiver electronics. This interface can be at a lower potential than the voltage used to source the LED.

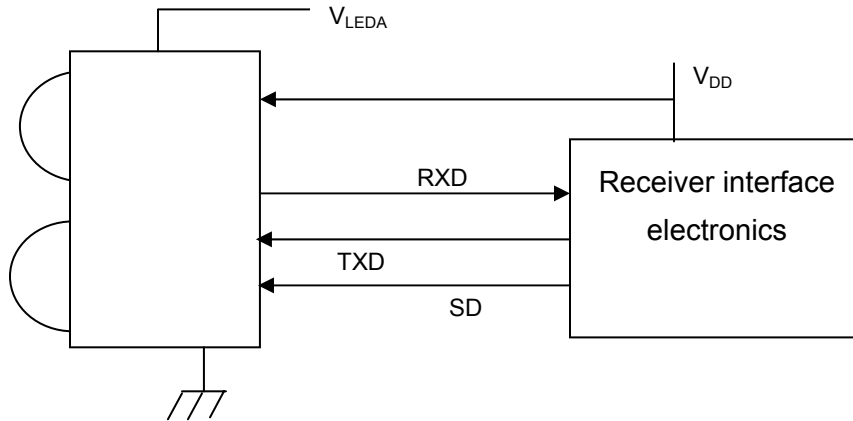

The  $V_{LEDA}$  voltage may be directly driven from the battery in the above design example. The  $V_{DD}$  associated with the Receiver interface electronics may be supported by a power regulator or other device providing an efficient regulated lower voltage source. This voltage may be as low as 2.0 Volts to 3.6 Volts, and the  $V_{LEDA}$  potential may range from 2.0 Volts to 6.0 Volts.

An alternative is to connect the  $V_{LEDA}$  and  $V_{DD}$  pins together as shown below. This arrangement allows the GP2W0110YP0F to go into previous applications where both of these voltage sources are connected. It is footprint and interface compatible with the previous Sharp GP2W0102YP, GP2W0104YP and GP2W0106YP

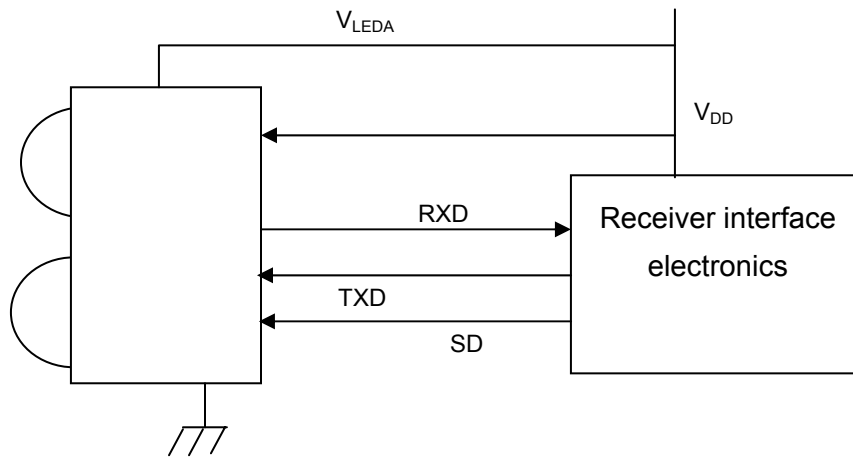

products.

**9-2 Shutdown Mode**

The "Shutdown" pinout is an active HIGH terminal, and performs the power saving function in accordance with following chart:

Input	Performance
HIGH	Shutdown Mode
LOW	Normal Operation Mode
OPEN	Normal Operation Mode

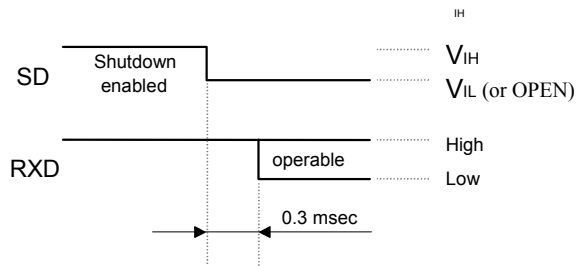

**9-3 Example of Signal Waveform**

The following drawing shows the waveform at each point in the block diagram to operate GP2W0110YP0F in a manner conforming to IrDA standards. The waveform example is only applicable as a design and evaluation reference to understand the GP2W0110YP0F hardware implementation and system measurement.

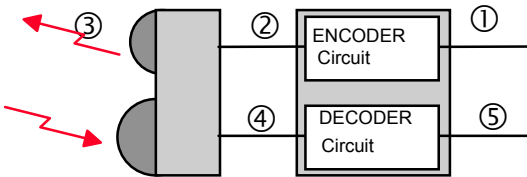

No.	Signal Description	Waveform
1	Transmitting Data Waveform	
2	Encoder Circuit Output Waveform	
3	Transmitter Output Optical Signal Waveform	
4	GP2W0110YP0F Receiver Output Waveform	
5	Receiving Data Waveform	

$T = 1 / \text{Data Rate}$

- Data Rate: 2.4 kbit/s, 9.6 kbit/s  
19.2 kbit/s, 38.4 kbit/s  
57.6 kbit/s, 115.2 kbit/s



**10-2. Designing IR Cosmetic Window**

Following figure and calculation explain the example and designing hints for cabinet and IR cosmetic window with  $\pm 18^\circ$  viewing angles, in vertical and horizontal axis. All values for the transceiver dimensions are applicable only for design reference, and in mm (UNIT). The IrDA specifications require a  $\pm 15^\circ$  viewing angle at the transceiver. The  $\pm 18^\circ$  angle shown is to provide a little extra clearance to allow for slight manufacturing variations and so that the required angle is always met.

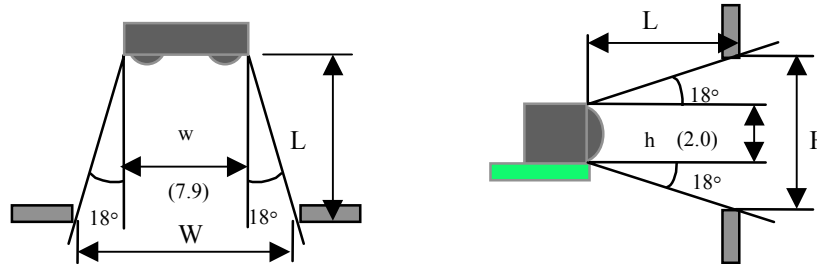

The optical window size should be the minimum size of W x H rectangular or elliptical in order not to reduce IrDA data transfer performance. The dimensions for W can be calculated by the formula of:

$$W = 2 \times L \times \tan 18^\circ + w$$

and the dimensions for H can be calculated by the formula of:

$$H = 2 \times L \times \tan 18^\circ + h$$

in case of having viewing angle of + 18, which conforms or exceeds the IrDA Serial Infrared Physical Layer Link Specifications. Any values to be calculated with above formula must be given in mm.

The dimension “7.9” as listed above is the physical length of the transceiver. This distance includes the side angles of the optical lenses to simplify the overall calculation. The height of the transceiver is 2.15 mm with the shield however the actual transceiver face in the optical resin is 2.0 mm. These dimensions are listed in the mechanical drawings.

**Product Packaging**

Many products that use infrared communication locate their reception component behind dark plastic. This often fits in with the overall design and coloring of the product, and has an intentional design purpose as well.

The photodiode that is used in optical receivers is sensitive to a range of light wavelengths, not only the wavelength intended for reception. Visible light has many component factors and sources in a room. The dark plastic used in product faceplates can be formulated to act as a highpass filter, reducing the amount of visible light and other wavelengths landing on the photodiode and raising the internal noise currents.

The reduction of unwanted wavelengths provides for a quieter and more sensitive receiver. The wavelength used for IrDA Data communication is 880 nm. The characteristic of any plastic used in a final product should keep this in mind and not attenuate this wavelength.

Glass and plastic filters are available on the market, and vendors carry plastic materials that may be cut, bent or molded. The key to selecting a plastics vendor is to ask them about the wavelength characteristics of their materials. The more they know, the more likely they will be able to help you in a knowledgeable manner when working on both the industrial design and wavelength pass characteristics of your IR window. If the vendor does not know what you are talking about, you need to find a more knowledgeable source for filter materials.



**Test and Evaluation Board**

Sharp Microelectronics has prepared an evaluation board for preliminary test of the GP2W0110YP0F transceiver. This board has also been developed to support the GP2W0112YPS transceiver, and that is why there are two resistor positions on the board. In the configuration for GP2W0110YP0F, R2 = 0 Ohms, and the R1 position is open. (The position for R1 will be loaded when the board is used for GP2W0112YP.)

The new low power 20 cm transceivers are so small that soldering directly to the contacts on the device is not an easy or effective connection method. Testing with an actual surface mount connection is the best method for evaluation. The PCB provides the electrical interface and a good ground-plane for test purposes. Connector J1 is the interface to the test system. The drawing shows that the device EMI shield should be connected to a good Ground in your final system.

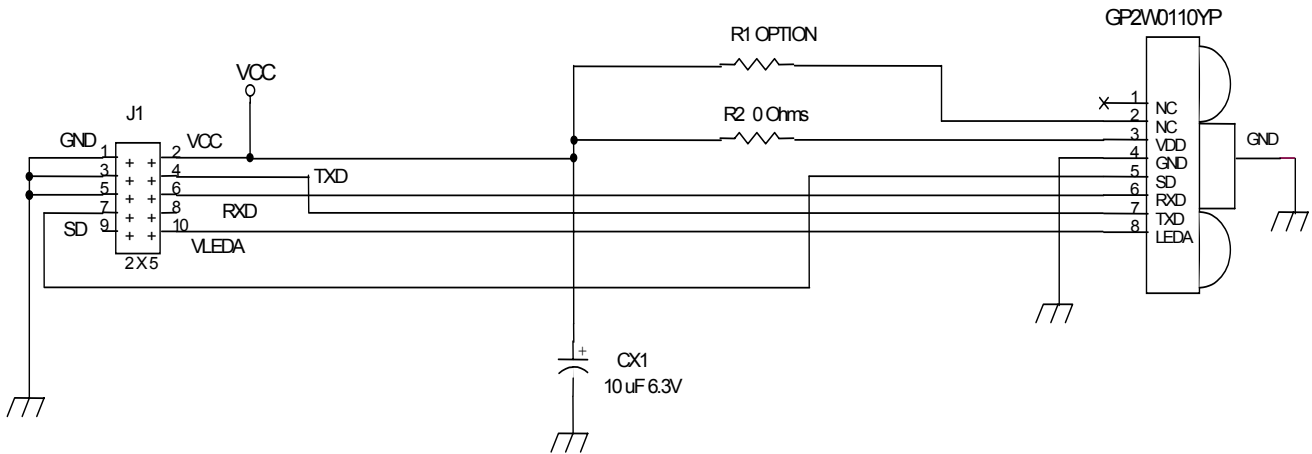

The value of capacitor CX1 is listed as 10  $\mu$ F. This value should be modified to meet your system electrical noise requirements. The decision should be based on the amount of system noise at the point where the IrDA transceiver will be powered. Both time-domain and frequency-domain noise issues should be considered. One common source of noise is switching power supplies, which need attention both on the power line and ground return paths.

As shown, capacitor CX1 is the only external component needed with the transceiver. If the power supply filtering in your system design is such that no capacitor is needed, there is no absolute requirement for it and that is a decision left to the design engineer.

**Note** that the  $V_{DD}$  connection and  $V_{LEDA}$  connections are now on separate pins. If  $V_{DD}$  and  $V_{LEDA}$  are to be powered from the same source, pins 2 and 10 needs to be externally connected.

Evaluation boards may be requested through any Sharp Microelectronics of the Americas Sales office.

**(Technical Information DISCLAIMER)**

This document is provided as a technical Guide for the Sharp GP2W0110YP0F Infrared Transceiver. Any of information under this document is applicable only for design reference purpose, and Sharp holds the right to change and alter information and prices at any time without notice. Contact SHARP, the Sharp web site or SHARP local representatives in order to obtain the latest version of the device Specification Sheets before using any SHARP's devices. In absence of confirmation by device Specification Sheets, SHARP takes no responsibility for any defects that occur in equipment using any of SHARP's device, shown in catalogues, data books, Preliminary Information, etc.

**LIFE SUPPORT POLICY**

SHARP components should not be used in medical devices with life support functions or in safety equipment (or similar applications where component failure result in loss of life or physical harm) without the written approval of an officer of the SHARP Corporation.

SHARP reserves the right to make changes in specifications at any time and without notice. SHARP does not

# SHARP

## **SHARP CORPORATION Japan**

INTERNATIONAL SALES & MARKETING GROUP  
-IC/ELECTRONIC COMPONENTS  
22-22 Nagaïke-cho, Abeno-Ku, OSAKA, 545, JAPAN  
PHONE: (81) 6-621-3129  
FAX: (81) 6-624-0163

## **NORTH AMERICA:**

### **SHARP MICROELECTRONICS OF THE AMERICAS**

5700 Northwest, Pacific Rim Boulevard #20  
Camas, WA 98607 U.S.A.  
PHONE: (1) 360-834-2500  
FAX: (1) 360-834-8903

## **EUROPE:**

### **SHARP ELECTRONICS (EUROPE) GmbH**

Microelectronics Division  
Sonninstrasse 3, 20097 Hamburg, Germany  
PHONE: (49) 40-2376-2286  
FAX: (49) 40-2376-2232

## **TAIWAN:**

### **SHARP ELECTRONIC COMPONENTS (TAIWAN) CORPORATION**

8 Fl., No. 16, Sec 4, Nanking E Rd.,  
Taipei, Taiwan, Republic of China  
PHONE: (886) 2-577-7341  
FAX: (886) 2-577-7326 / 2-577-7328

## **HONG KONG**

### **SHARP - ROXY (HONG KONG) LTD.**

3rd Business Division,  
Room 1701 - 1711, Admiralty Centre Tower 1,  
Harcourt Road, Hong Kong  
PHONE: (852) 28229311  
FAX: (852) 28660779

## **SINGAPORE:**

### **SHARP ELECTRONICS (SINGAPORE) PTE., LTD.**

438A, Alexandra Road, #05-01/02,  
Alexandra Technopark, Singapore 119967  
PHONE: (65) 271-3566  
FAX: (65) 271-3855

## **KOREA:**

### **SHARP ELECTRONIC COMPONENTS (KOREA) CORPORATION**

RM 501 Geosung B/D.  
541, Dohwa-dong, Mapo-ku, Seoul, Korea  
PHONE: (82) 2-711-5813 ~ 8  
FAX: (82) 2-711-5819