

HSDL-3021

IrDA® Data Compliant Low Power 4.0 Mbit/s
with Remote Control Infrared Transceiver

LITEON®

Data Sheet

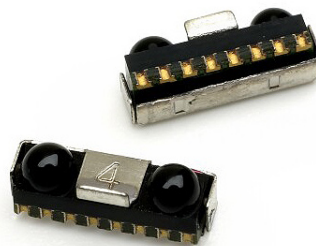

Description

The HSDL-3021 is a new generation low profile high speed enhanced infrared (IR) transceiver module that provides the capability of (1) interface between logic and IR signals for through-air, serial, half-duplex IR data link, and (2) IR remote control transmission for universal remote control applications. The HSDL-3021 can be used for IrDA as well as remote control application without the need of any additional external components for multiplexing.

The HSDL-3021 is fully compliant to IrDA® Physical Layer specification version 1.4 low power from 9.6 kbit/s to 4.0 Mbit/s (FIR) and IEC825 Class 1 eye safety standards.

The HSDL-3021 can be shut down completely to achieve very low power consumption. In the shut-down mode, the PIN diode will be inactive and thus produce very little photocurrent even under very bright ambient light. It is also designed to interface to input/output logic circuits as low as 1.5 V. These features are ideal for battery operated mobile devices such as PDAs and mobile phones that require low power consumption.

Applications

- Mobile data communication and universal remote control
 - Mobile phones
 - PDAs
 - Webpads

Features

General Features

- Operating temperature from -25°C ~ 85°C
 - Critical parameters are guaranteed over temperature and supply voltage
- V_{CC} supply 2.4 to 3.6 volts
- Miniature package
 - Height: 2.5 mm
 - Width: 8.0 mm
 - Depth: 3.0 mm
- Integrated remote control LED driver
- Input/output interface voltage of 1.5 V
- Integrated EMI shield
- LED stuck-high protection
- Designed to accommodate light loss with cosmetic windows
- IEC 825-Class 1 eye safe
- Interface to various super I/O and controller devices
- Lead free package

IrDA® Features

- Fully compliant to IrDA 1.4 Physical Layer Low Power Specifications from 9.6 kbit/s to 4.0 Mb/s
 - Link distance up to 50 cm typically
- Complete shutdown for TxD_IrDA, RxD_IrDA and PIN diode
- Low power consumption
 - Low shutdown current

Remote Control Features

- Wide angle and high radiant intensity
- Spectrally suited to remote control function at 890 nm typically
- Typical link distance up to 8 meters (on-axis)

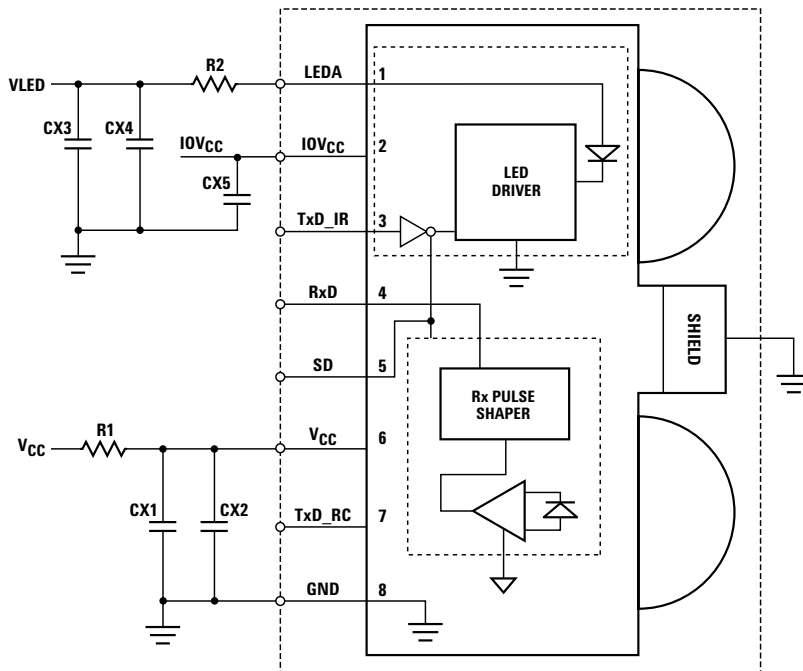

Figure 1. HSDL-3021 block diagram.

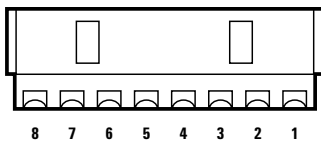

Figure 2. Pinout.

Application Support Information

The Application Engineering Group is available to assist you with the application design associated with HSDL-3021 infrared transceiver module. You can contact them through your local sales representatives for additional details.

Order Information

Part Number	Packaging Type	Package	Quantity
HSDL-3021-021	Tape and Reel	Front Option	2500

Marking Information

The unit is marked with "HYWLL" on the shield
 Y = Year
 W = Work week
 LL = Lot information

I/O Pins Configuration Table

Pin	Symbol	Description	I/O Type	Notes
1	LEDA	LED Anode		Note 1
2	IOV _{CC}	Input/Output ASIC Voltage		Note 2
3	TxD_IR	IrDA Transmitter Data Input	Input. Active High	Note 3
4	RxD	IrDA Receive Data	Output. Active Low	Note 4
5	SD	Shutdown	Input. Active High	Note 5
6	V _{CC}	Supply Voltage		Note 6
7	TxD_RC	RC Transmitter Data Input	Input. Active High	Note 7
8	GND	Ground		Note 8
–	Shield	EMI shield		Note 9

Notes:

1. Tied through external resistor, R2, to Vled. Refer to the table below for recommended series resistor value.
2. Connect to ASIC logic controller supply voltage or V_{CC}. The voltage at this pin should be equal to or less than V_{CC}.
3. This pin is used to transmit serial data when SD pin is low. If held high for longer than 50 μs, the LED is turned off. Do NOT float this pin.
4. This pin is capable of driving a standard CMOS or TTL load. No external pull-up or pull-down resistor is required. The pin is in tri-state when the transceiver is in shutdown mode.
5. Complete shutdown of IC and PIN diode. The pin is used for setting IR receiver bandwidth, range of IR LED current and RC drive programming mode. Refer to section on "Bandwidth Selection Timing" and "Remote Control Drive Modes" for more information. Do NOT float this pin. ***
6. Regulated, 2.4 V to 3.6 V.
7. Logic high turns on the RC LED. If held high longer than 50 μs, the RC LED is turned off. Do NOT float the pin.
8. Connect to system ground.
9. Connect to system ground via a low inductance trace. For best performance, do not connect directly to the transceiver GND pin.

Recommended Application Circuit Components

Component	Recommended Value	Note
R1	4.7 Ω, ± 5%, 0.25 watt	
R2	2.7 Ω, for 2.4 < VLED ≤ 2.7 V; 3.3 Ω, for 2.7 < VLED ≤ 3.0 V 3.9 Ω, for 3.0 < VLED ≤ 3.3 V 4.7 Ω, for 3.3 < VLED ≤ 3.6 V 5.6 Ω, for 3.6 < VLED ≤ 4.2 V 10 Ω, for 4.2 < VLED ≤ 5 V	
CX1, CX3, CX5	100 nF, ± 20%, X7R Ceramic	1
CX2, CX4	4.7 μF, ± 20%, Tantalum	1

Note:

1. CX1, CX2, CX3 & CX4 must be placed within 0.7 cm of HSDL-3021 to obtain optimum noise immunity.

CAUTIONS: The BiCMOS inherent to the design of this component increases the component's susceptibility to damage from electrostatic discharge (ESD). It is advised that normal static precautions be taken in handling and assembly of this component to prevent damage and/or degradation which may be induced by ESD.

Absolute Maximum Ratings

For implementations where case to ambient thermal resistance is $\leq 50^\circ\text{C}/\text{W}$.

Parameter	Symbol	Min.	Max.	Units	Conditions
Storage Temperature	T_S	-40	+100	$^\circ\text{C}$	
Operating Temperature	T_A	-25	+85	$^\circ\text{C}$	
LED Anode Voltage	V_{LEDA}	0	6.5	V	
Supply Voltage	V_{CC}	0	6	V	
Input Voltage: TXD, SD/Mode	V_I	0	5.5	V	
Input/Output Supply Voltage: RXD	IOV_{CC}	0	6	V	
IR LED Current Pulse Amplitude	$I_{(VLED)IR}$		190	mA	$\leq 25\%$ duty cycle, $\leq 90\ \mu\text{s}$ pulse width
RC LED Current Pulse Amplitude	$I_{(VLED)RC}$		400	mA	$\leq 10\%$ duty cycle, $\leq 90\ \mu\text{s}$ pulse width

Recommended Operating Conditions

Parameter	Symbol	Min.	Typ.	Max.	Units	Conditions
Operating Temperature	T_A	-25		+85	$^\circ\text{C}$	
Supply Voltage	V_{CC}	2.4		3.6	V	
Input/Output Voltage	IOV_{CC}	1.5		3.6	V	
Logic Input Voltage for TXD, SD/Mode	Logic High	V_{IH}		$IOV_{CC} - 0.5$	V	
	Logic Low	V_{IL}		0.5	V	
Receiver Input Irradiance	Logic High	E_{IH}	0.0090	500	mW/cm ²	For in-band signals $\leq 115.2\ \text{kbit/s}^{[3]}$
			0.0225	500		0.576 Mbit/s \leq in-band signals $\leq 4.0\ \text{Mbit/s}^{[3]}$
	Logic Low	E_{IL}		0.3	$\mu\text{W}/\text{cm}^2$	For in-band signals ^[3]
IR LED (Logic High) Current Pulse Amplitude – SIR Mode	I_{LEDA}		65		mA	
IR LED (Logic High) Current Pulse Amplitude – MIR/FIR Mode	I_{LEDA}		150		mA	
RC LED (Logic High) Current Pulse Amplitude	I_{LEDA}		250		mA	
Receiver Data Rate		0.0096		4.0	Mbit/s	
Ambient Light						See IrDA Serial Infrared Physical Layer Link Specification, Appendix A for ambient levels

Note:

- An in-band optical signal is a pulse/sequence where the peak wavelength, λ_p , is defined as $850 \leq \lambda_p \leq 900\ \text{nm}$, and the pulse characteristics are compliant with the IrDA Serial Infrared Physical Layer Link Specification v1.4.

Electrical and Optical Specifications

Specifications (Min. & Max. values) hold over the recommended operating conditions unless otherwise noted. Unspecified test conditions may be anywhere in their operating range. All typical values (Typ.) are at 25°C with V_{CC} set to 3.0 V and IOV_{CC} set to 1.8 V unless otherwise noted.

Parameter		Symbol	Min.	Typ.	Max.	Units	Conditions
Receiver							
Viewing Angle		2θ _{1/2}	30			°	
Peak Sensitivity Wavelength λ _p			885			nm	
RxD_IrDA Output Voltage	Logic High	V _{OH}	IOV _{CC} - 0.5		IOV _{CC}	V	I _{OH} = -200 μA, E _I ≤ 0.3 μW/cm ²
	Logic Low	V _{OL}	0		0.4	V	
RxD_IrDA Pulse Width (SIR) ^[4]		t _{RPW} (SIR)	1		4	μs	θ _{1/2} ≤ 15°, C _L = 9 pF
RxD_IrDA Pulse Width (MIR) ^[4]		t _{RPW} (MIR)	100		500	ns	θ _{1/2} ≤ 15°, C _L = 9 pF
RxD_IrDA Pulse Width (Single) (FIR) ^[4]		t _{RPW} (FIR)	80		175	ns	θ _{1/2} ≤ 15°, C _L = 9 pF
RxD_IrDA Pulse Width (Double) (FIR) ^[4]		t _{RPW} (FIR)	200		290	ns	θ _{1/2} ≤ 15°, C _L = 9 pF
RxD_IrDA Rise & Fall Times	t _r , t _f		40			ns	C _L = 9 pF
Receiver Latency Time ^[5]		t _L			100	μs	E _I = 9.0 μW/cm ²
Receiver Wake Up Time ^[6]		t _{RW}			200	μs	E _I = 10 mW/cm ²
Infrared (IR) Transmitter							
IR Radiant Intensity (SIR Mode)		I _{EH}	4			mW/sr	IR_I _{LEDA} = 65 mA, θ _{1/2} ≤ 15°, TxD_IR ≥ V _{IH} , T _A = 25°C
IR Radiant Intensity (MIR/FIR Mode)		I _{EH}	10			mW/sr	IR_I _{LEDA} = 150 mA, θ _{1/2} ≤ 15°, TxD_IR ≥ V _{IH} , T _A = 25°C
IR Viewing Angle		2θ _{1/2}	30		60	°	
IR Peak Wavelength		λ _p		885		nm	
TxD_IrDA Logic Levels	High	V _{IH}	IOV _{CC} - 0.5		IOV _{CC}	V	
	Low	V _{IL}	0		0.5	V	
TxD_IrDA Input Current	High	I _H		0.02		μA	V _I ≥ V _{IH}
	Low	I _L		-0.02		μA	0 ≤ V _I ≤ V _{IL}
Wake Up Time ^[7]		t _{TW}		180		ns	
Maximum Optical Pulse Width ^[8]		t _{PW} (max)		25	50	μs	
TXD Pulse Width (SIR)		t _{PW} (SIR)		1.6		μs	t _{PW} (TXD_IR) = 1.6 μs at 115.2 kbit/s
TXD Pulse Width (MIR)		t _{PW} (MIR)		217		ns	t _{PW} (TXD_IR) = 217 ns at 1.152 Mbit/s
TXD Pulse Width (FIR)		t _{PW} (FIR)		125		ns	t _{PW} (TXD_IR) = 125 ns at 4.0 Mbit/s
TxD Rise & Fall Times (Optical)		t _r , t _f			600	ns	t _{PW} (TXD_IR) = 1.6 μs at 115.2 kbit/s
					40	ns	t _{PW} (TXD_IR) = 125 ns at 4.0 Mbit/s

Electrical and Optical Specifications (Cont'd.)

Parameter	Symbol	Min.	Typ.	Max.	Units	Conditions
IR LED Anode On-State Voltage (SIR Mode)	V_{ON} (IR_LEDA)		2.19		V	IR_I _{LEDA} = 65 mA, IR V _{LED} = 3.6 V, R = 13 Ω, V _I (TxD) ≥ V _{IH}
IR LED Anode On-State Voltage (MIR/FIR Mode)	V_{ON} (IR_LEDA)		2.22		V	IR_I _{LEDA} = 150 mA, IR V _{LED} = 3.6 V, R = 13 Ω, V _I (TxD_IR) ≥ V _{IH}

Remote Control (RC) Transmitter

RC Radiant Intensity		I_{EH}		50		mW/sr	RC_I _{LEDA} = 250 mA, θ _{1/2} ≤ 15°, TxD_RC ≥ V _{IH} , T _A = 25°C
RC Viewing Angle		2θ _{1/2}	30		60	°	
RC Peak Wavelength		λ _p		885		nm	
TxD_RC Logic Levels	High	V _{IH}	IOV _{CC} - 0.5		IOV _{CC}	V	
	Low	V _{IL}	0		0.5	V	
TxD_RC Input Current	High	I _H		0.02	1	μA	V _I ≥ V _{IH}
	Low	I _L		-0.02	1	μA	0 ≤ V _I ≤ V _{IL}
RC LED Anode On-State Voltage		V_{ON} (RC_LEDA)		2.08		V	RC_I _{LEDA} = 250 mA, RC V _{LED} = 3.6 V, R = 3.9 Ω, V _I (TxD_RC) ≥ V _{IH}

Transceiver

Input Current	High	I _H		0.01	1	μA	V _I ≥ V _{IH}
	Low	I _L	-1	-0.02	1	μA	0 ≤ V _I ≤ V _{IL}
Supply Current	Shutdown	I _{CC1}			1	μA	V _{SD} ≥ V _{CC} - 0.5, T _A = 25°C
	Idle (Standby)	I _{CC2}		2.0	2.9	mA	V _I (TxD) ≤ V _{IL} , EI = 0
	Active	I _{CC3}		3.5		mA	V _I (TxD) ≥ V _{IL} , EI = 10 mW/cm ²

Notes:

- An in-band optical signal is a pulse/sequence where the peak wavelength, λ_p, is defined as 850 nm ≤ λ_p ≤ 900 nm, and the pulse characteristics are compliant with the IrDA Serial Infrared Physical Layer Link Specification version 1.4.
- For in-band signals 115.2 kbit/s where 9 μW/cm² ≤ EI ≤ 500 mW/cm².
- For in-band signals 1.152 Mbit/s where 22 μW/cm² ≤ EI ≤ 500 mW/cm².
- For in-band signals 4 Mbit/s where 22 μW/cm² ≤ EI ≤ 500 mW/cm².
- Latency is defined as the time from the last TxD_IrDA light output pulse until the receiver has recovered full sensitivity.
- Receiver Wake Up Time is measured from V_{CC} power ON to valid RxD_IrDA output.
- Transmitter Wake Up Time is measured from V_{CC} power ON to valid light output in response to a TxD_IrDA pulse.
- The Max Optical PW is defined as the maximum time which the IR LED will turn on. This is to prevent the long Turn On time for the IR LED.

Timing Waveforms

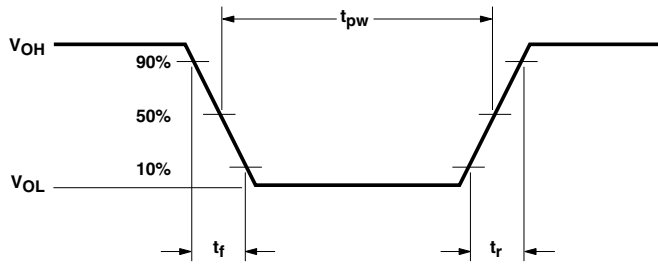

Waveform 1. RXD output waveform

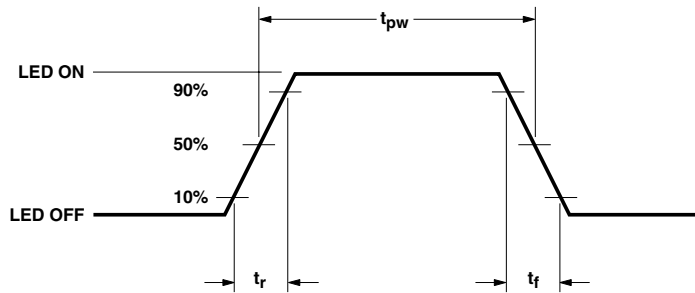

Waveform 2. LED optical waveform

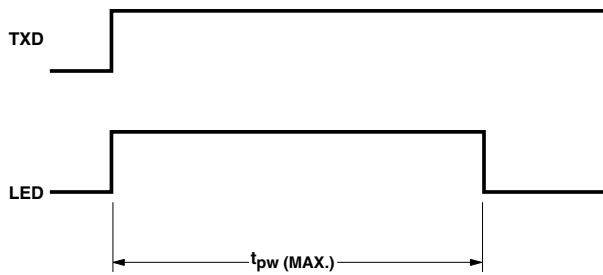

Waveform 3. TXD "stuck on" protection waveform

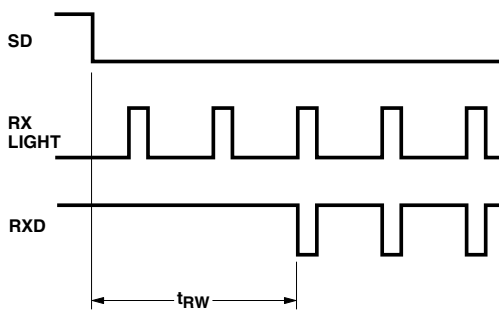

Waveform 4. Receiver wakeup time waveform

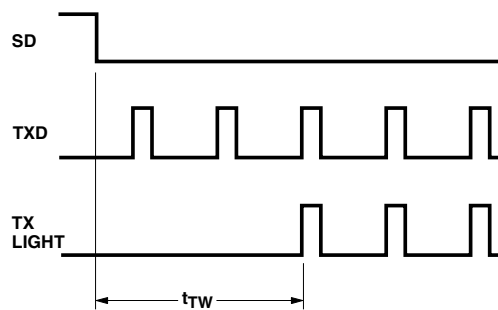

Waveform 5. TXD wakeup time waveform

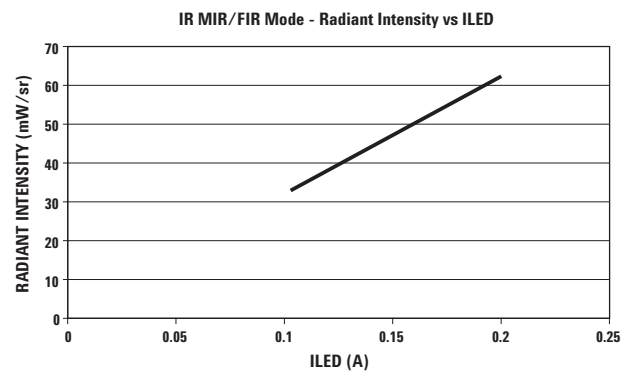
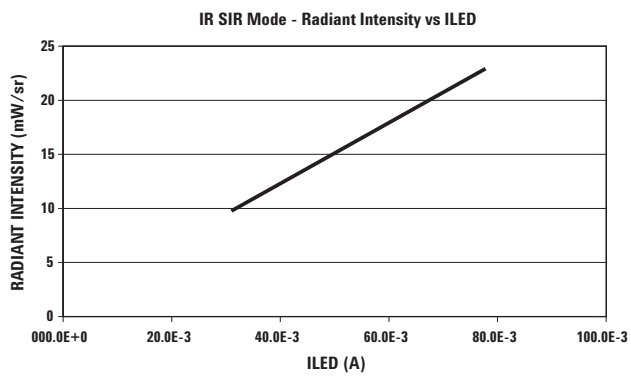
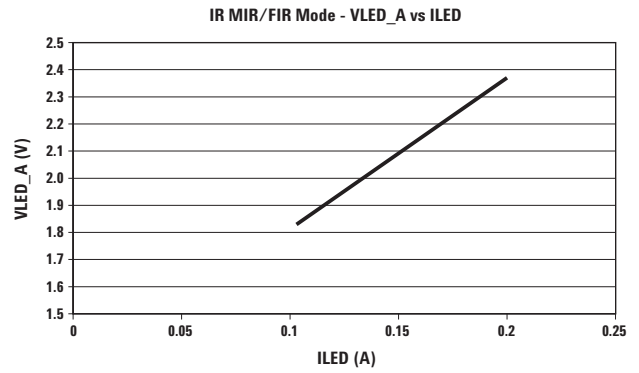
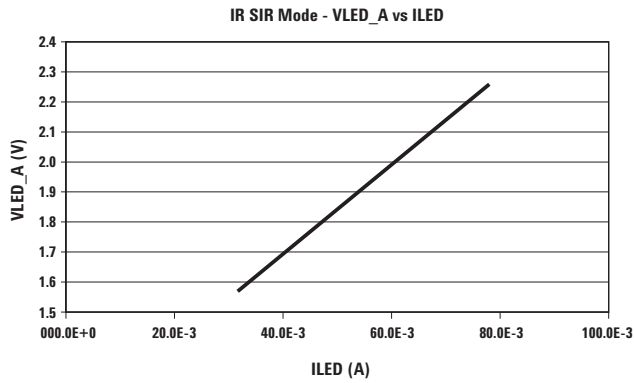

HSDL-3021 Package Dimensions

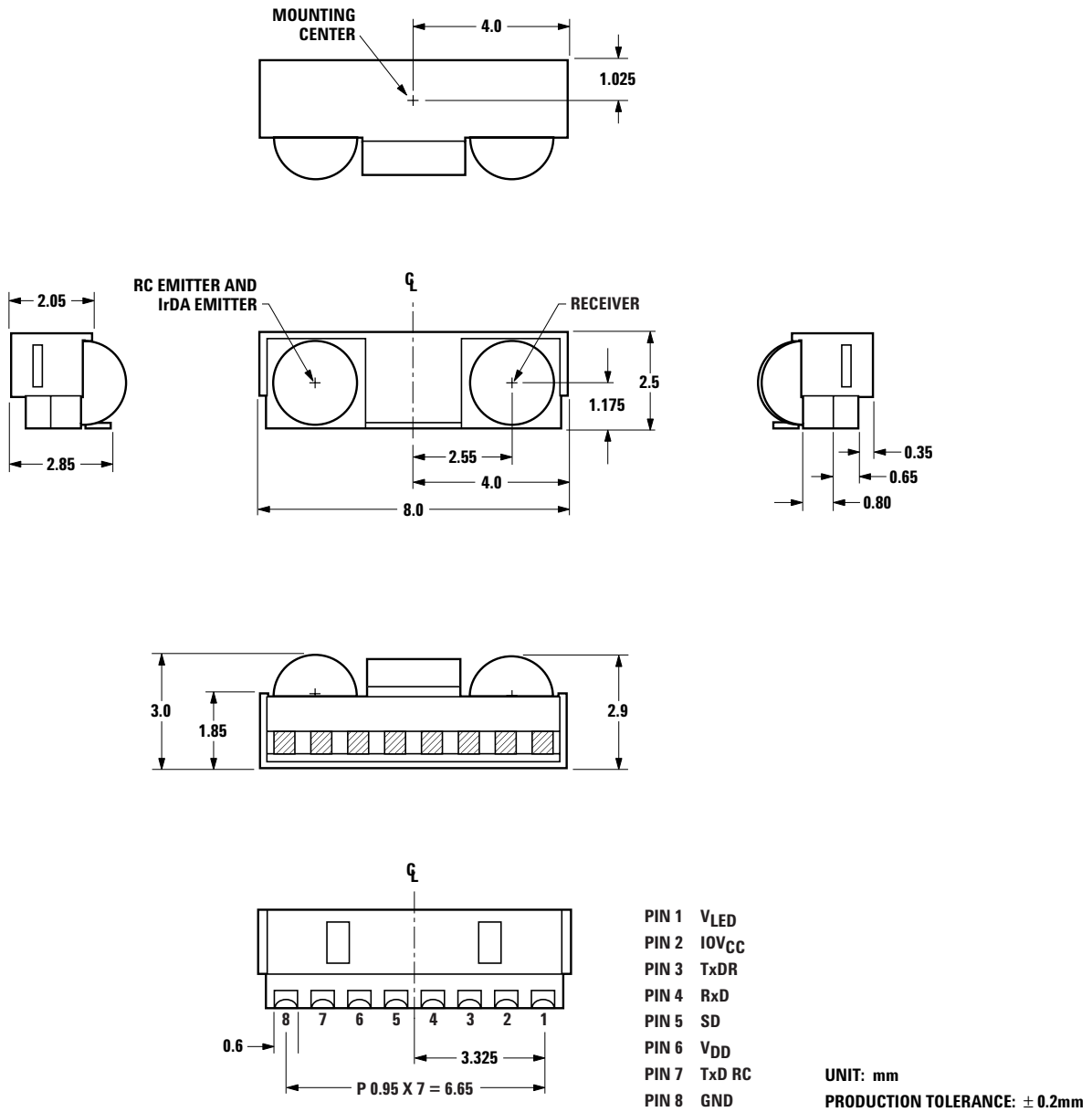

HSDL-3021 Tape and Reel Dimensions

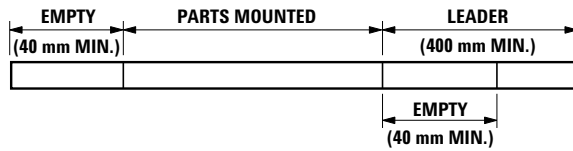
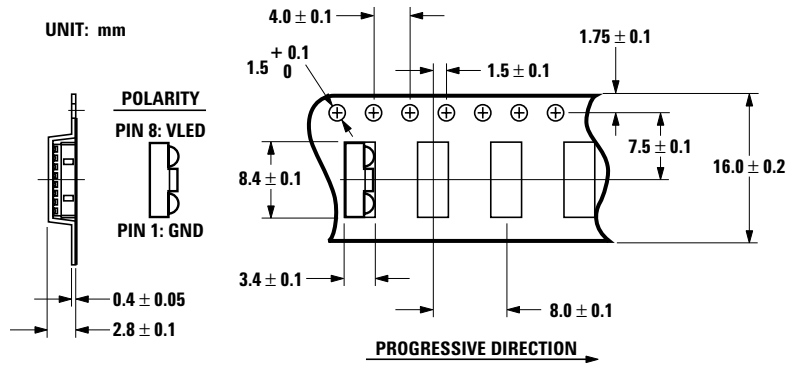

OPTION #	"B"	"C"	QUANTITY
001	178	60	500
021	330	80	2500

UNIT: mm

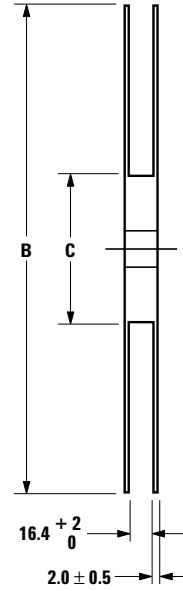
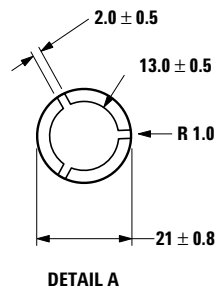
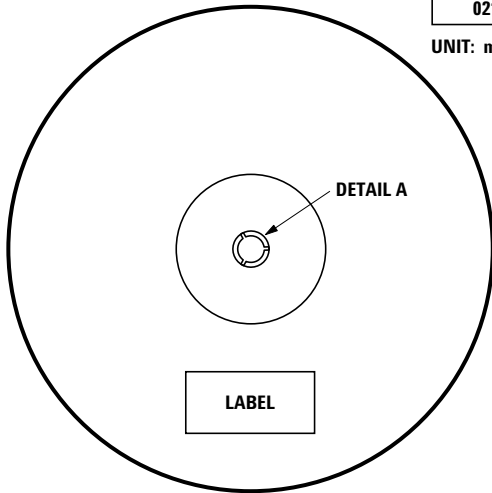

HSDL-3021 Moisture Proof Packaging

All HSDL-3021 options are shipped in moisture proof package. Once opened, moisture absorption begins.

This part is compliant to JEDEC Level 4.

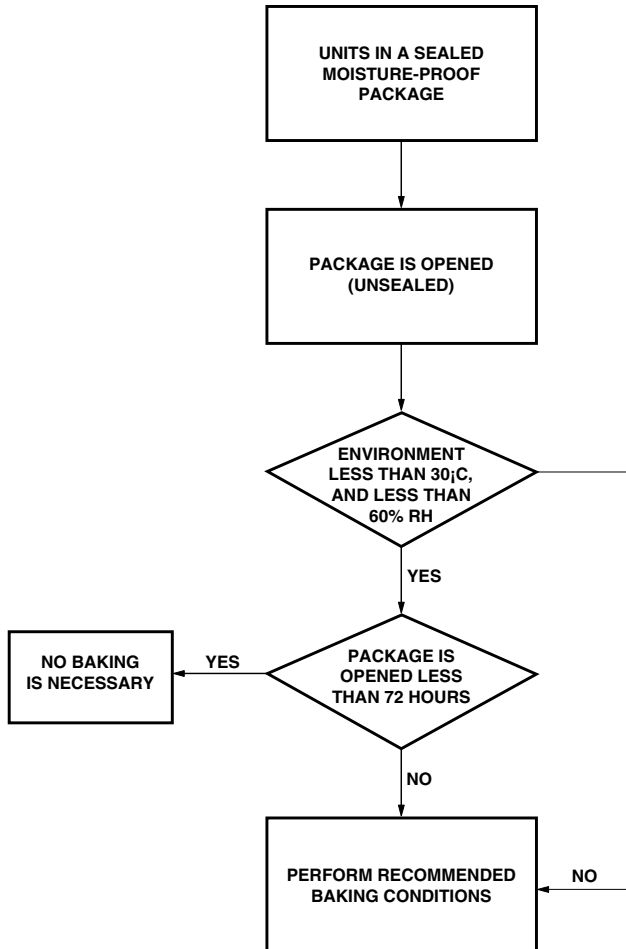

Figure 3. Baking conditions chart.

Recommended Storage Conditions

Storage Temperature 10°C to 30°C

Relative Humidity Below 60% RH

Time From Unsealing To Soldering

After removal from the bag, the parts should be soldered within three days if stored at the recommended storage conditions. When MBB (Moisture Barrier Bag) is opened and the parts are exposed to the recommended storage conditions more than three days but less than 15 days, the parts must be baked before reflow to prevent damage to the parts.

Note: Using the parts that are exposed for more than 15 days is not recommended.

Baking Conditions

Package	Temp	Time
In reels	60°C	≥ 48 hours
In bulk	100°C	≥ 4 hours
	125°C	≥ 2 hours

Note: Baking should only be done once.

Recommended Reflow Profile

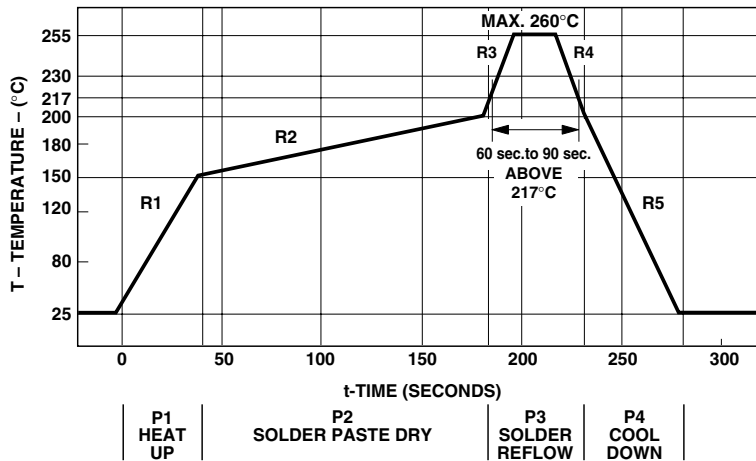

Process Zone	Symbol	ΔT	Maximum $\Delta T/\Delta$ Time or Duration
Heat Up	P1, R1	25°C to 150°C	3°C/s
Solder Paste Dry	P2, R2	150°C to 200°C	100s to 180s
Solder Reflow	P3, R3	200°C to 260°C	3°C/s
	P3, R4	260°C to 200°C	-6°C/s
Cool Down	P4, R5	200°C to 25°C	-6°C/s
Time maintained above liquidus point, 217°C		>217°C	60s to 90s
Peak Temperature		260°C	-
Time within 5°C of actual Peak Temperature		-	20s to 40s
Time 25°C to Peak Temperature		25°C to 260°C	8 mins

The reflow profile is a straight-line representation of a nominal temperature profile for a convective reflow solder process. The temperature profile is divided into four process zones, each with different $\Delta T/\Delta$ time temperature change rates, or duration. The $\Delta T/\Delta$ time rates, or duration, are detailed in the above table. The temperatures are measured at the component to printed circuit board connections.

In **process zone P1**, the PC board and HSDL-3021 pins are heated to a temperature of 150°C to activate the flux in the solder paste. The temperature ramp up rate, R1, is limited to 3°C per second to allow for even heating of both the PC board and HSDL-3021 pins.

Process zone P2 should be of sufficient time duration (100 to 180 seconds) to dry the solder paste. The temperature is raised to a level just below the liquidus point of the solder.

Process zone P3 is the solder reflow zone. In zone P3, the temperature is quickly raised above the liquidus point of solder to 260°C (500°F) for optimum results. The dwell time above the liquidus point of solder should be between 60 and 90 seconds. This is to assure proper coalescing of the solder paste into liquid solder and the formation of good solder connections. Beyond the recommended dwell time, the intermetallic growth within the solder connections becomes excessive, resulting in the formation of weak and unreliable connections. The temperature is then rapidly reduced to a point below the solidus temperature of the solder to allow the solder within the connections to freeze solid.

Process zone P4 is the cool down after solder freeze. The cool down rate, R5, from the liquidus point of the solder to 25°C (77°F) should not exceed 6°C per second maximum. This limitation is necessary to allow the PC board and HSDL-3021 pins to change dimensions evenly, putting minimal stresses on the HSDL-3021.

It is recommended to perform reflow soldering no more than twice.

Appendix A: HSDL-3021 SMT Assembly Application Note

Solder Pad, Mask and Metal Stencil

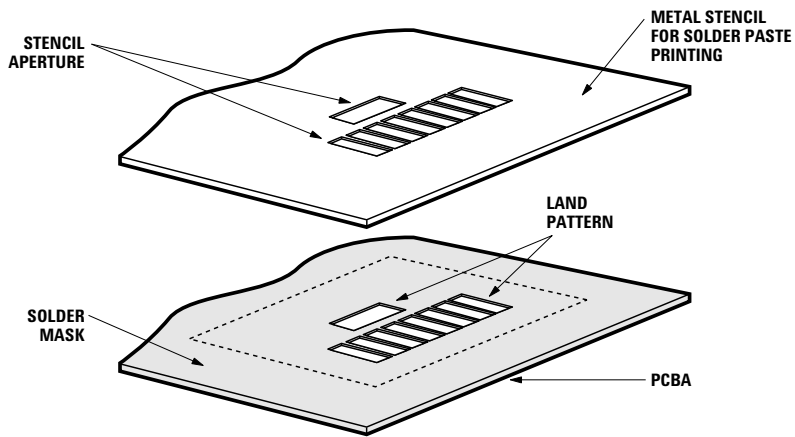

Figure 1. Stencil and PCBA.

Recommended Land Pattern

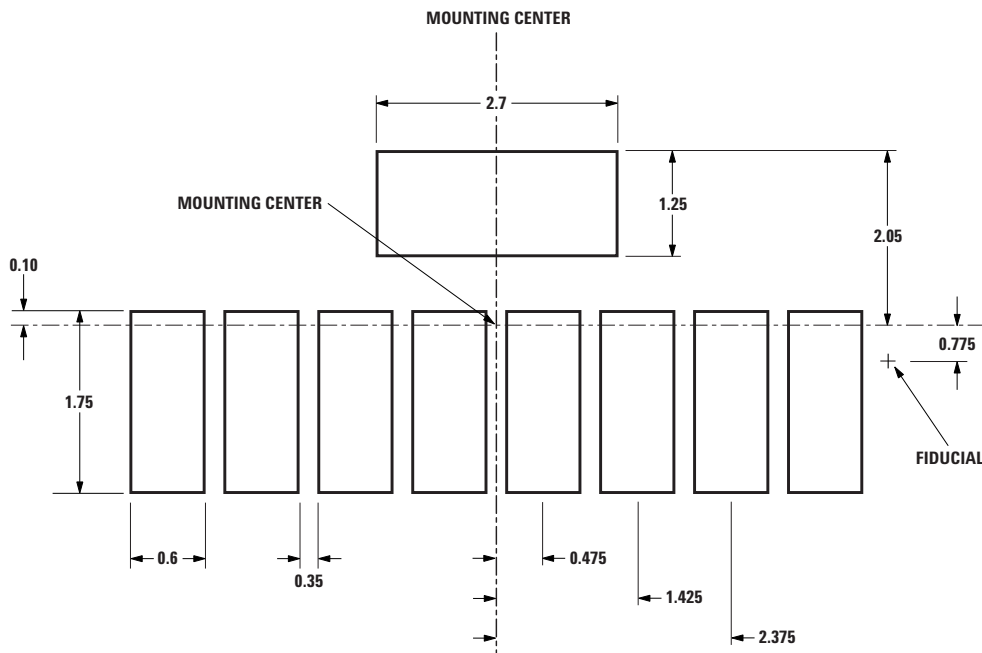

Figure 2.

Recommended Metal solder Stencil Aperture

It is recommended that only a 0.152 mm (0.006 inch) or a 0.127 mm (0.005 inch) thick stencil be used for solder paste printing. This is to ensure adequate printed solder paste volume and no shorting. See Table 1 below the drawing for combinations of metal stencil aperture and metal stencil thickness that should be used. Aperture opening for shield pad is 3.05 mm x 1.1 mm as per land pattern.

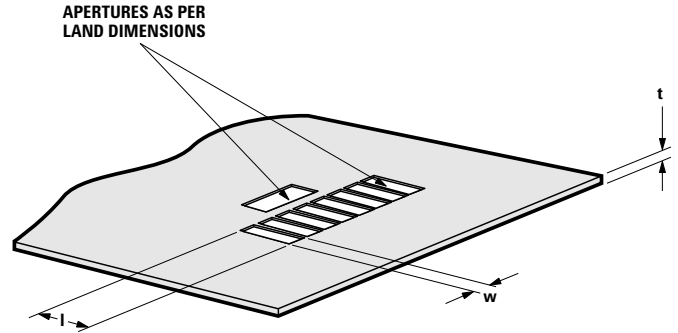

Figure 3. Solder stencil aperture.

Table 1.

Stencil Thickness, t (mm)	Aperture Size(mm)	
	Length, l	Width, w
0.127 mm	1.75 ± 0.05	0.55 ± 0.05
0.11 mm	2.4 ± 0.05	0.55 ± 0.05

Adjacent Land Keepout and Solder Mask Areas

Adjacent land keepout is the maximum space occupied by the unit relative to the land pattern. There should be no other SMD components within this area. The minimum solder resist strip width required to avoid solder bridging adjacent pads is 0.2 mm. It is recommended that two fiducial crosses be placed at mid length of the pads for unit alignment.

Note: Wet/Liquid Photo-imaginable solder resist/mask is recommended.

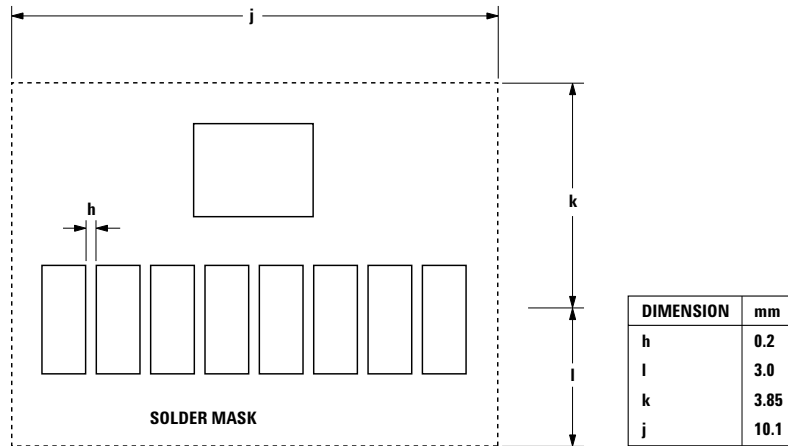

Appendix B: PCB Layout Suggestion

The effects of EMI and power supply noise can potentially reduce the sensitivity of the receiver, resulting in reduced link distance. The PCB layout played an important role to obtain a good PSRR and EM immunity resulting in good electrical performance. Things to note:

1. The ground plane should be continuous under the part, but should not extend under the shield trace.
2. The shield trace is a wide, low inductance trace back to the system ground. CX1, CX2, CX3, CX4 and CX5 are optional supply filter capacitors; they may be left out if a clean power supply is used.
3. VLED can be connected to either unfiltered or unregulated power supply. The bypass capacitors should be connection before the current limiting resistor R2 respectively. In a noisy environment, including capacitor CX3 and CX4 can enhance supply rejection. CX3 that is generally a ceramic capacitor of low inductance providing a wide frequency response while CX4 is tantalum capacitor of big volume and fast frequency response. The use of a tantalum capacitor is more critical on the VLED line, which carries a high current.
4. V_{CC} pin can be connected to either unfiltered or unregulated power supply. The Resistor, R1 together with the capacitors, CX1 and CX2 acts as the low pass filter.
5. IOV_{CC} is connected to the ASIC voltage supply or the VCC supply. The capacitor, CX5 acts as the bypass capacitor.
6. Preferably a multi-layered board should be used to provide sufficient ground plane. Use the layer underneath and near the transceiver module as V_{cc}, and sandwich that layer between ground connected board layers. The diagram below demonstrate an example of a 4 layer board:

- **Top Layer:** Connect the metal shield and module ground pin to bottom ground layer; Place the bypass capacitors within 0.5 cm from the V_{CC} and ground pin of the module.
- **Layer 2:** Critical ground plane zone. 3 cm in all directions around the module. Connect to a clean, noiseless ground node (e.g., bottom layer).
- **Layer 3:** Keep data bus away from critical ground plane zone.
- **Bottom layer:** Ground layer. Ground noise <75 mVp-p. Should be separated from ground used by noisy sources.

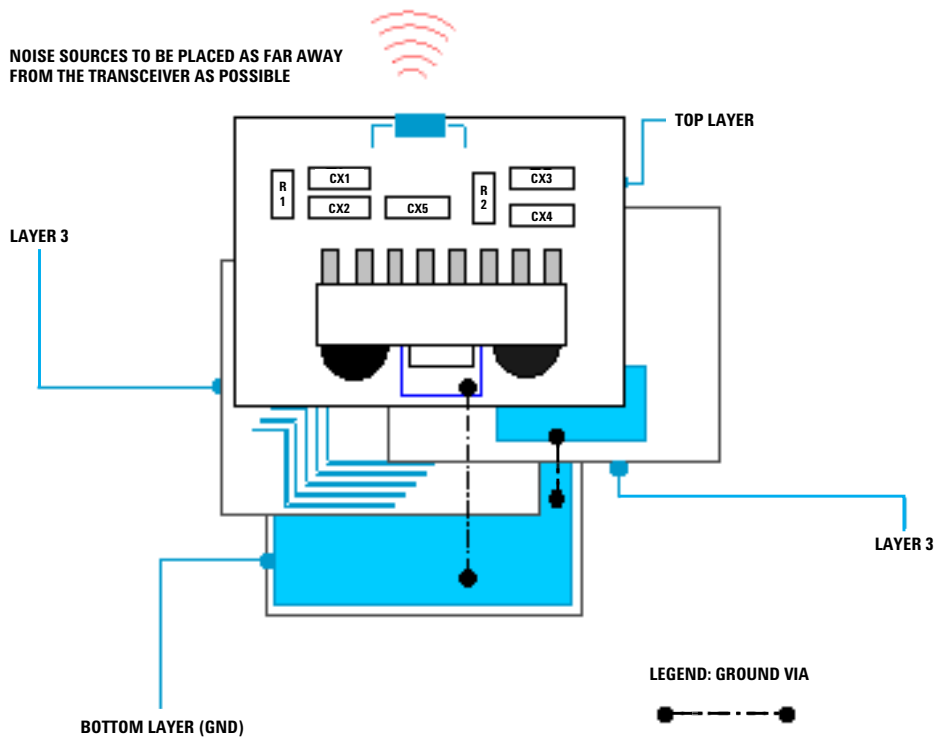

The area underneath the module at the second layer, and 3 cm in all directions around the module, is defined as the critical ground plane zone. The ground plane should be maximized in this zone. Refer to application note AN1114 or the *Lite-On IrDA Data Link Design Guide* for details. The layout below is based on a 2-layer PCB.

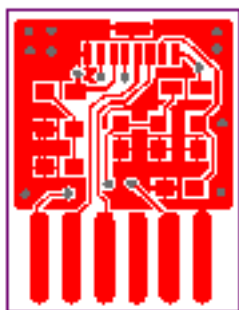

Top Layer



Bottom Layer

Appendix C: General Application Guide for the HSDL-3021 infrared IrDA Compliant 4 Mb/s Transceiver

Description

The HSDL-3021, a wide-voltage operating range infrared transceiver is a low-cost and small form factor device that is designed to address the mobile computing market such as PDAs, as well as small embedded mobile products such as digital cameras and cellular phones. It is spectrally suited to universal remote control transmission function at 940 nm typically. It is fully compliant to IrDA 1.4 low power specification up 4Mb/s and support most remote control codes. The design of HSDL-3021 also includes the following unique features :

- Spectrally suited to universal remote control transmission function at 940 nm typically
- Low passive component count
- Shutdown mode for low power consumption requirement
- Direct interface with I/O logic circuit

Interface to the Recommended I/O Chip

The HSDL-3021's TXD data input is buffered to allow for CMOS drive levels. No peaking circuit or capacitor is required. Data rate from 9.6 kb/s to 4 Mb/s is available at RXD pin. The TXD_RC, pin 7, together with LEDA, pin1, is used to select the remote control transmit mode. Alternatively, the TXD_IR, pin 3, together with LEDA, pin 1, is used for infrared transmit selection.

Following shows the hardware reference design with HSDL-3021.

* Detailed configuration of HSDL-3021 with the controller chip is shown in Figure 3.

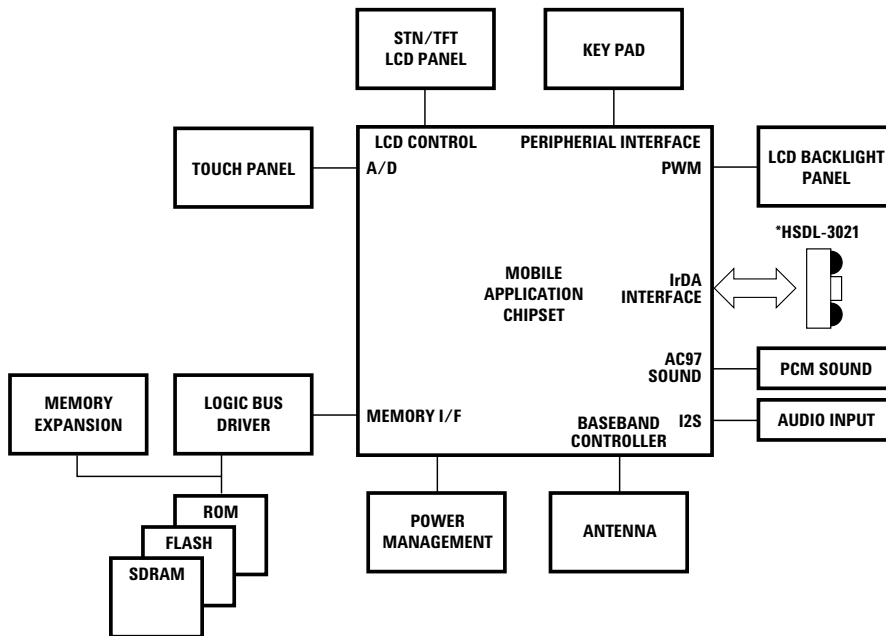

Figure 2: Mobile application platform.

Selection of Resistor R2

Resistor R2 should be selected to provide the appropriate peak pulse IR and RC LED current respectively at different ranges of V_{CC} as shown on page 3 under "Recommended Application circuit components."

The use of the infrared techniques for data communication has increased rapidly lately and almost all mobile application processors have built in the IR port. This does away with the external Endec and simplifies the interfacing to a direct connection between the processor and the transceiver. The next section discusses interfacing configuration with a general processor.

General Mobile Application Processor

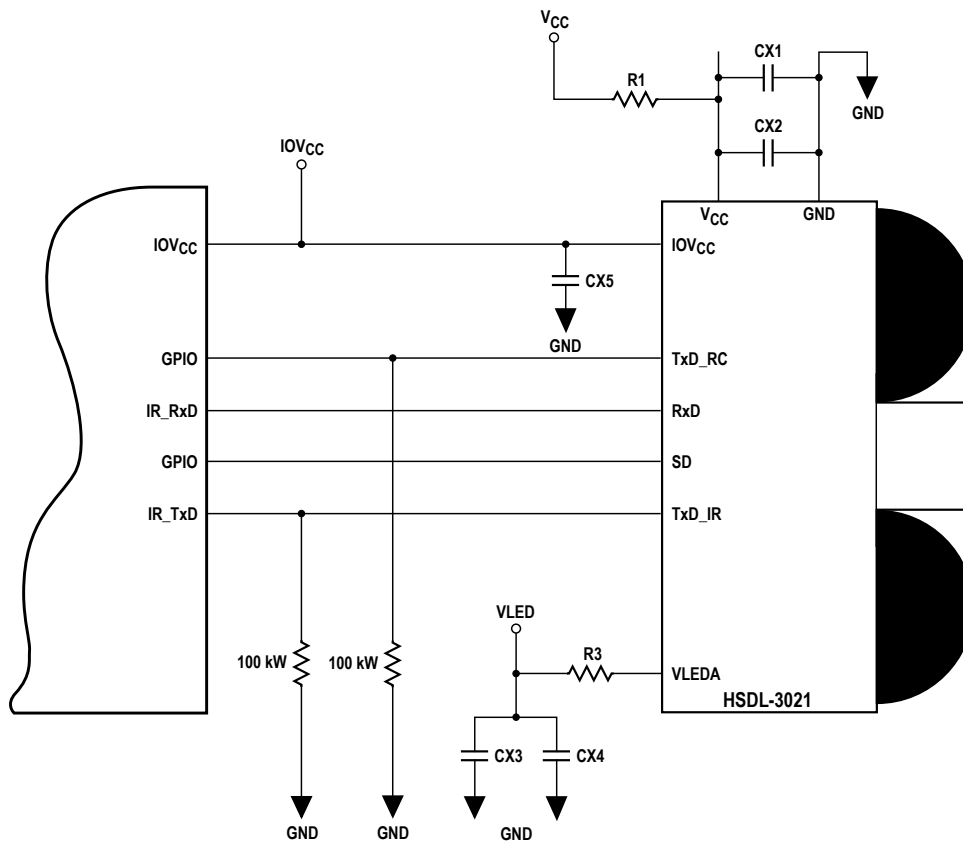

Figure 3: HSDL-3021 configuration with general mobile architecture processor.

The transceiver is directly interfaced with the microprocessor provided its support infrared communication commonly known as Infrared Communications Port (ICP). The ICP supports both SIR data rates up to 115.2 kps and sometimes FIR data with data rates up to 4 Mbps. The remote control commands can be sent to one of the available General Purpose IO pins or the UART block with IrDA functionality. It should be observed that although both

IrDA data transmission and Remote control transmission is possible simultaneously by the hardware, the software is required to resolve this issue to prevent the mixing and corruption of data while being transmitted over the free air. The above Figure 3 illustrates a reference interfacing to implement both IR and RC functionality with HSDL-3021.

Remote Control Operation

The HSDL-3021 is spectrally suited to universal remote control transmission function at 940 nm typically. Remote control applications are not governed by any standards, owing to which there are numerous remote codes in market. Each of those standards results in receiver modules with different sensitivities, depending on the carrier frequencies and responsively to the incident light wavelength. Remote control carrier frequencies are in the range of 30 KHz to 60 KHz (for details of some the frequently used carrier frequencies, please refer to AN1314). Some common carrier frequencies and the corresponding SA-1110 UART frequency and baud rate divisor are shown in Table 3.

Table 3.

Remote Control Carrier Frequency (kHz)	SA-1110 UART Frequency (kHz)	Baud Rate Divisor
30	28.8	8
32, 33	32.9	7
36, 36.7, 38, 39.2, 40	38.4	6
56	57.6	4

Appendix D: Window Design for HSDL-3021

Optical Port Dimensions for HSDL-3021

To ensure IrDA compliance, some constraints on the height and width of the window exist. The minimum dimensions ensure that the IrDA cone angles are met without vignetting. The maximum dimensions minimize the effects of stray light. The minimum size corresponds to a cone angle of 30° and the maximum size corresponds to a cone angle of 60° .

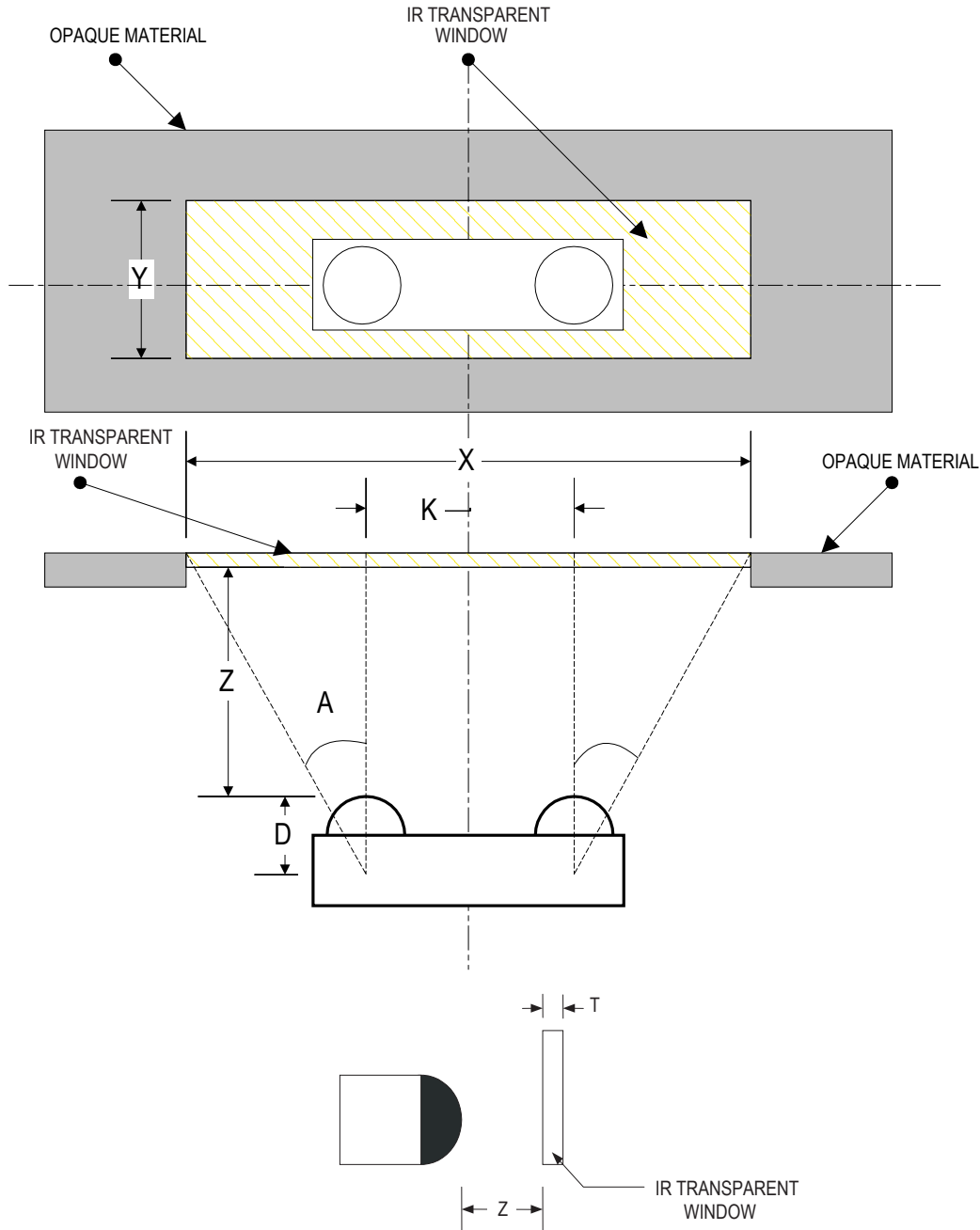

In the figure above, X is the width of the window, Y is the height of the window and Z is the distance from the HSDL-3021 to the back of the window. The distance from the center of the LED lens to the center of the photodiode lens, K, is 5.1mm. The equations for computing the window dimensions are as follows:

$$X = K + 2*(Z+D)*\tan A$$

$$Y = 2*(Z+D)*\tan A$$

The above equations assume that the thickness of the window is negligible compared to the distance of the module from the back of the window (Z). If they are comparable,

$$W1 = 0.33*T,$$

$$W2 = 0.66*T,$$

where T is the window thickness and the refractive index of the window material is 1.586.

The depth of the LED image inside the HSDL-3021, D, is 3.17mm. 'A' is the required half angle for viewing. For IrDA compliance, the minimum is 15° and the maximum is 30°. The equations result in the following tables and graphs. The graphs are plotted assuming that the thickness of the window is negligible.

Module Depth (Z) mm	Aperture Width (X, mm)		Aperture height (Y, mm)	
	Min	Max	Min	Max
0	6.80 + W1	8.76 + W2	1.70 + W1	3.66 + W2
1	7.33 + W1	9.92 + W2	2.23 + W1	4.82 + W2
2	7.87 + W1	11.07 + W2	2.77 + W1	5.97 + W2
3	8.41 + W1	12.22 + W2	3.31 + W1	7.12 + W2
4	8.94 + W1	13.38 + W2	3.84 + W1	8.28 + W2
5	9.48 + W1	14.53 + W2	4.38 + W1	9.43 + W2
6	10.01 + W1	15.69 + W2	4.91 + W1	10.59 + W2
7	10.55 + W1	16.84 + W2	5.45 + W1	11.74 + W2
8	11.09 + W1	18.00 + W2	5.99 + W1	12.90 + W2
9	11.62 + W1	19.15 + W2	6.52 + W1	14.05 + W2

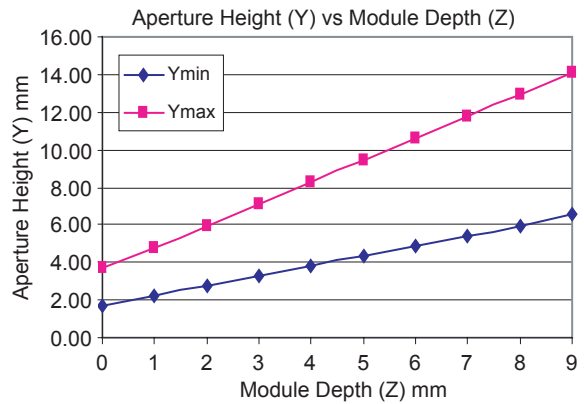
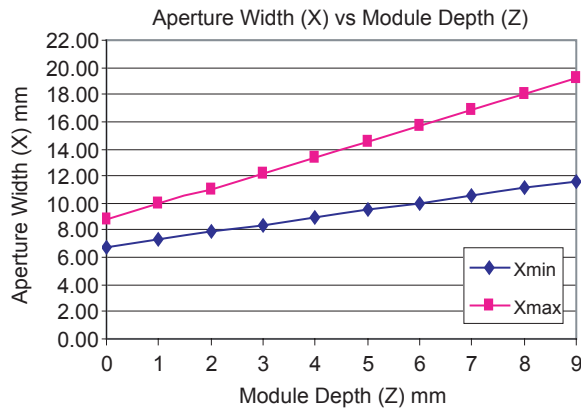

It is recommended that the tolerance for assembly be considered as well. The recommended minimum window size which will take into account of the assembly tolerance is defined as:

$$X_{min} + \text{assembly tolerance} = X_{min} + 2*(\text{assembly tolerance}) \text{ (Dimensions are in mm)}$$

$$Y_{min} + \text{assembly tolerance} = Y_{min} + 2*(\text{assembly tolerance}) \text{ (Dimensions are in mm)}$$

Window Material

Almost any plastic material will work as a window material. Polycarbonate is recommended. The surface finish of the plastic should be smooth, without any texture. An IR filter dye may be used in the window to make it look black to the eye, but the total optical loss of the window should be 10% or less for best optical performance. Light loss should be measured at 875 nm. The recommended plastic materials for use as a cosmetic window are available from General Electric Plastics.

Recommended Plastic Materials:

Material #	Light Transmission	Haze	Refractive Index
Lexan 141	88%	1%	1.586
Lexan 920A	85%	1%	1.586
Lexan 940A	85%	1%	1.586

Note: 920A and 940A are more flame retardant than 141.
Recommended Dye: Violet #21051 (IR transmissant above 625 nm)

Shape of the Window

From an optics standpoint, the window should be flat. This ensures that the window will not alter either the radiation pattern of the LED, or the receive pattern of the photodiode. If the window must be curved for mechanical or industrial design reasons, place the same curve on the backside of the window that has an identical radius as the front side. While this will not completely eliminate the lens effect of the front curved surface, it will significantly reduce the effects. The amount of change in the radiation pattern is dependent upon the material chosen for the window, the radius of the front and back curves, and the distance from the back surface to the transceiver. Once these items are known, a lens design can be made which will eliminate the effect of the front surface curve. The following drawings show the effects of a curved window on the radiation pattern. In all cases, the center thickness of the window is 1.5 mm, the window is made of polycarbonate plastic, and the distance from the transceiver to the back surface of the window is 3 mm.

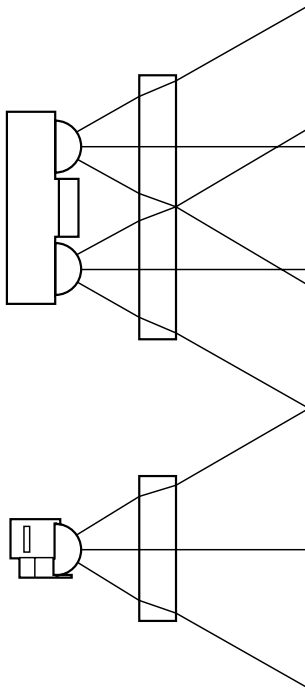

**Flat Window
(First Choice)**

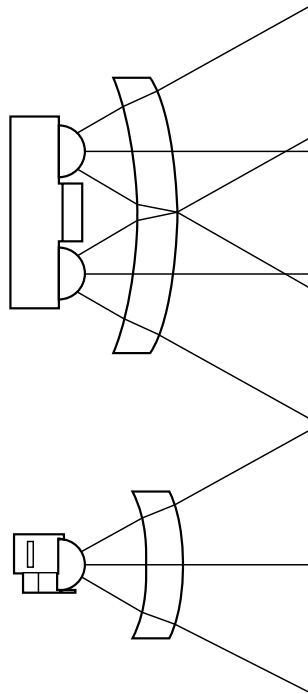

**Curved Front and Back
(Second Choice)**

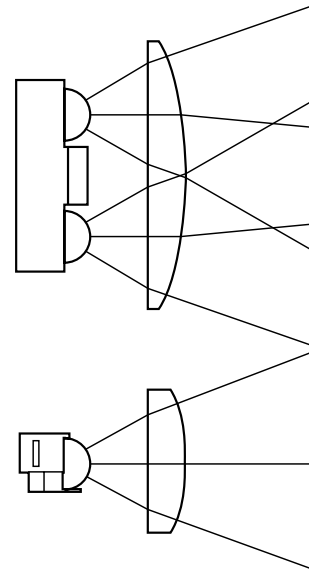

**Curved Front, Flat Back
(Do not use)**

Appendix E: General Application Guide for the HSDL-3021

Remote Control Drive Modes

The HSDL-3021 can operate in the *single-TxD programmable mode* or the *two-TxD direct transmission mode*.

Single-TxD Programmable Mode

In the single-TxD programmable mode, only one input pin (TxD_IR input pin) is used to drive the LED in both IrDA mode as well as Remote Control mode of operation. This mode can be used when the external controller uses only one transmit pin for both IrDA as well RC mode of operation.

The transceiver is in default mode (IrDA-SIR) when powered up. The user needs to apply the following programming sequence to both the TxD_IR and SD inputs to enable the transceiver to operate in either the IrDA or remote control mode.

Two-TxD Direct Transmission Mode

In the two-TxD direct transmission mode, the LED can be driven separately for IrDA and RC mode of operation through the TxD_IR and TxD_RC pins respectively. This mode can be used when the external controller utilizes separate transmit pins for IrDA and RC operation modes, thereby eliminating the need for external multiplexing.

Please refer to the Transceiver I/O truth table for more detail.

Transceiver Control I/O Truth Table for Two-TxD Direct Transmission Mode

SD	TxIR	TxRC	LED	Remarks
0	0	0	OFF	IR Rx enabled. Idle mode
0	0	1	ON	Remote control operation
0	1	0	ON	IrDA Tx operation
0	1	1	-	Not recommended (both transmitters off)
1	0	0	OFF	Shutdown mode*

*The shutdown condition will set the transceiver to the default mode (IrDA-SIR)

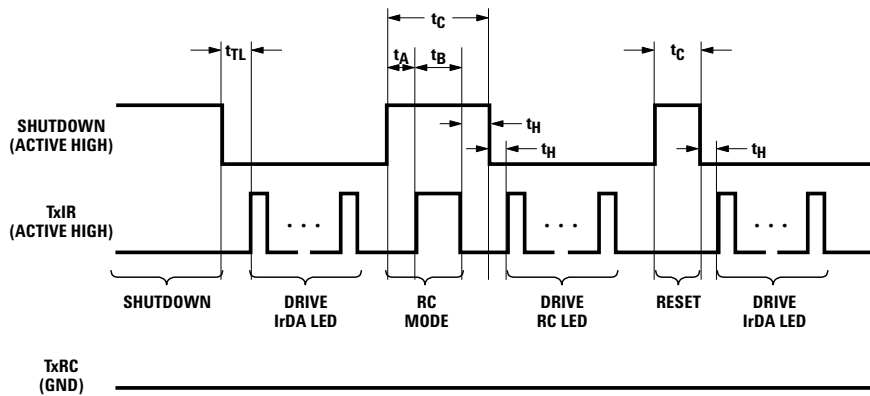

Mode Programming Timing Table

Parameter	Symbol	Min	Typ	Max	Unit	Notes
The following timings describe input constraints required using the active serial interface for mode programming with pins SD, TxIR, and TxRC:						
Shutdown Input Pulse Width, at Pin SD	t_{SDPW}	30	-	∞	μs	Will activate complete shutdown
SD Mode Setup Time	t_A	200	-	-	ns	Setup for mode programming
TxIR Pulse Width for RC Mode	t_B	200	-	-	ns	RC drive enabled with pin TxIR
SD Programming Pulse Width Note: ($t_A + t_B$) < t_C < t_{SDPW}	t_C	-	-	5.0	μs	Pulse width mode programming
TxIR Setup Time for SIR or MIR/FIR Mode	t_S	50	-	-	ns	Setup time for IrDA bandwidth selection
TxIR or SD Hold Time to Latch SIR, MIR/FIR or RC Mode	t_H	50	-	-	ns	Hold time for IrDA or RC modes

Bandwidth Selection Timing

The power on state should be the IrDA SIR mode. The data transfer rate must be set by a program-ming sequence using the TxD_IR and SD inputs as described below.

Note: SD should not exceed the maximum, $t_C \leq 5 \mu\text{s}$, to prevent shutdown.

Setting to the High Bandwidth MIR/FIR Mode (0.576 Mbits/s to 4 Mbits/s)

1. Set SD input to logic "HIGH." Wait $t_A \geq 200 \text{ ns}$.
2. Set TxD_IR input to logic "HIGH." Wait $t_S \geq 50 \text{ ns}$.
3. Set SD to logic "LOW" (this negative edge latches state of TxD_IR, which determines speed setting).
4. After waiting $t_H \geq 50 \text{ ns}$ TxD_IR can be set to logic "LOW." TxD_IR is now re-enabled as normal IrDA transmit input for the High Bandwidth MIR/FIR mode.

Setting to the Low Bandwidth SIR Mode (2.4 kbits/s to 115.2 kbits/s)

1. Set SD input to logic "HIGH."
2. Set TxIR input to logic "LOW." Wait $t_S \geq 50 \text{ ns}$.
3. Set SD to logic "LOW" (this negative edge latches state of TxIR, which determines speed setting).
4. TxIR must be held for $t_S \geq 50 \text{ ns}$. TxIR is now re-enabled as normal IrDA transmit input for the Low Bandwidth SIR mode.

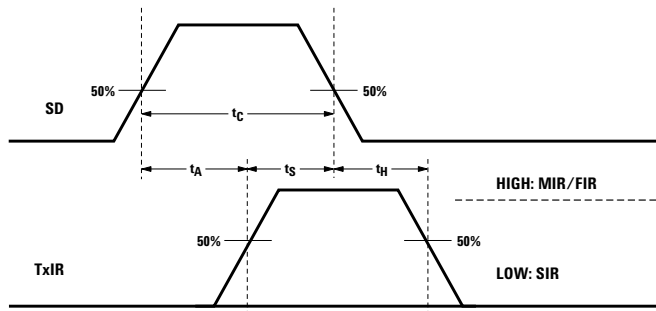

Power-Up Sequencing

To have a proper operation for HSDL-3201, the following power-up sequencing must be followed.

- a) It is strongly recommended that V_{CC} must come prior to IOV_{CC} .

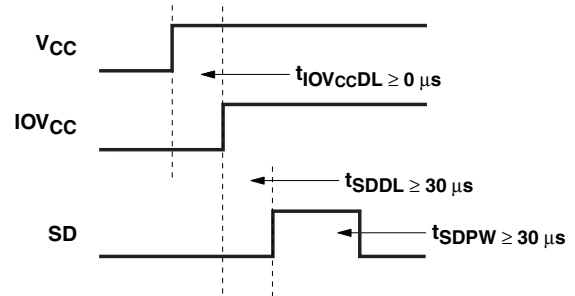

- b) It is not recommended to turn on IOV_{CC} before V_{CC} while SD is low. However, for application that IOV_{CC} comes prior to V_{CC} while SD is low, SD pin has to be set high to assure proper functionality.

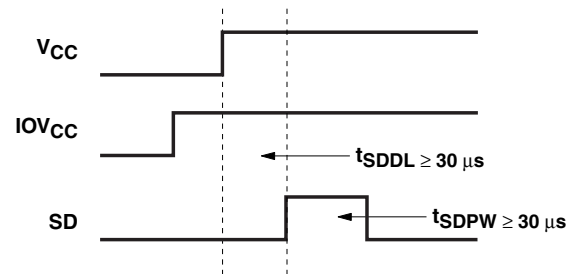

- c) Setting IOV_{CC} high before V_{CC} while SD is high is forbidden.

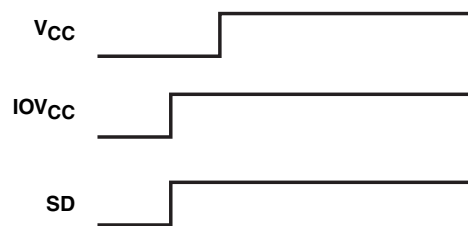

Note:

$t_{IOV_{CC}DL}$ = IOV_{CC} delay time

t_{SDDL} = SD delay time

t_{SDPW} = shutdown input pulse width

For company and product information, please go to our web site: WWW.liteon.com or <http://optodatabook.liteon.com/databook/databook.aspx>

Data subject to change. Copyright © 2007 Lite-On Technology Corporation. All rights reserved.

LITEON®