

Revolutionary High-performance High-quality Sensor with Built-in Amp



- Optical axis can be adjusted in seconds because the optical axis coincides with the mounting axis.
- Highly visible spot on white paper (except 10-cm and 70-cm Diffuse Reflective Sensors).
- Two-turn sensitivity adjustment with consistent scale reading to enable setting multiple sensors without adjusting each individually (for Diffuse Reflective Sensors).
- Stable detection at a distance of from 0.2 to 70 cm (E3S-Adj 2, E3S-Adj 7).
- Washable in water (IP67, NEMA 4X enclosure rating).
- A total of 72 different modes to match essentially every need.
- Built-in mutual interference prevention function. E39-E6/E8 Filters for mutual interference prevention available.



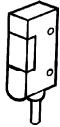

Ordering Information

■ E3S-A General-purpose Sensors

Connections	Appearance	Sensing method	Sensing distance	Operating modes	Output/timer functions	Model		
						NPN output	PNP output	
Prewired	 Horizontal	Through-beam	7 m	Light-ON Dark-ON (selectable)	---	E3S-AT11	E3S-AT31	
						With timer and self-diagnostic functions	E3S-AT21	E3S-AT41
		Retroreflective	0.1 to 2 m (polarized)		---	E3S-AR11	E3S-AR31	
						With timer and self-diagnostic functions	E3S-AR21	E3S-AR41
		Diffuse reflective	10 cm (light source: infrared)		---	E3S-AD13	E3S-AD33	
							With timer and self-diagnostic functions	E3S-AD23
			20 cm		---	E3S-AD11	E3S-AD31	
							With timer and self-diagnostic functions	E3S-AD21
			70 cm (light source: infrared)		---	E3S-AD12	E3S-AD32	
							With timer and self-diagnostic functions	E3S-AD22

Connections	Appearance	Sensing method	Sensing distance	Operating modes	Output/timer functions	Model		
						NPN output	PNP output	
Prewired		Through-beam	7 m	Light-ON Dark-ON (selectable)	---	E3S-AT61	E3S-AT81	
			Retroreflective		0.1 to 2 m (polarized)	With timer and self-diagnostic functions	E3S-AT71	E3S-AT91
					Diffuse reflective	10 cm (light source: infrared)	---	E3S-AR61
		20 cm	With timer and self-diagnostic functions				E3S-AR71	E3S-AR91
		70 cm (light source: infrared)	---			E3S-AD63	E3S-AD83	
			With timer and self-diagnostic functions		E3S-AD73	E3S-AD93		
		---	E3S-AD61		E3S-AD81			
		With timer and self-diagnostic functions	E3S-AD71		E3S-AD91			
		---	E3S-AD62		E3S-AD82			
		With timer and self-diagnostic functions	E3S-AD72		E3S-AD92			
Connector		Through-beam	7 m	---	---	E3S-AT16	E3S-AT36	
			Retroreflective			0.1 to 2 m (polarized)	E3S-AR16	E3S-AR36
		Diffuse reflective					10 cm (light source: infrared)	E3S-AD18
						20 cm	E3S-AD16	E3S-AD36
		70 cm (light source: infrared)	E3S-AD17			E3S-AD37		
			Through-beam			7 m	E3S-AT66	E3S-AT86
						Retroreflective	0.1 to 2 m (polarized)	E3S-AR66
	Diffuse reflective		10 cm (light source: infrared)		E3S-AD68			E3S-AD88
			20 cm		E3S-AD66		E3S-AD86	
	70 cm (light source: infrared)		E3S-AD67		E3S-AD87			

■ E3S-B Miniature Sensors





Connections	Appearance	Sensing method	Sensing distance	Operating modes	Output/timer functions	Model	
						NPN output	PNP output
Prewired		Through-beam	2 m	Light-ON Dark-ON (selectable)	---	E3S-BT11	E3S-BT31
			Retroreflective			0.1 to 1 m (polarized)	E3S-BR11
		Diffuse reflective					20 cm
		Through-beam	2 m			E3S-BT61	E3S-BT81
			Retroreflective			0.1 to 1 m (polarized)	E3S-BR61
		Diffuse reflective					20 cm

■ Accessories (Order Separately)

E3S-A General-purpose Sensor Accessories

Name	Model	Remarks
Slit for Through-beam Sensor	E39-S46	2-mm, 1-mm, and 0.5-mm slits are sold in pairs, one each for the receiver and emitter of a through-beam model
Mounting Bracket for Vertical Sensor	E39-L59	Purchase two brackets for each through-beam model
	E39-L81	
Filter for Mutual Interference Prevention (for Through-beam Sensor)	E39-E6	4 filters are sold together for two through-beam models (2 filters each for the emitters and receivers)
Reflector for Optical Axis Adjustment (for Through-beam Sensor)	E39-R5	One only

Plugs (for Sensors with Connector Terminals)

Cord	Appearance	Cord length	Model
Standard	Straight (3 conductor)	 2 m	XS2F-D421-DC0-A
		5 m	XS2F-D421-GC0-A
	L-shape (3 conductor)	 2 m	XS2F-D422-DC0-A
		5 m	XS2F-D422-GC0-A
Robot (vibration-proof)	Straight (4 conductor)	 2 m	XS2F-D421-D80-R
		5 m	XS2F-D421-G80-R
	L-shape (4 conductor)	 2 m	XS2F-D422-D80-R
		5 m	XS2F-D422-G80-R

E3S-B Miniature Sensor Accessories

Name	Model	Remarks
Slit for Through-beam Sensor	E39-S47 (sealed tape type)	2-mm dia., 1-mm dia., and 0.5-mm dia. slits are sold in pairs, one each for the receiver and emitter of a through-beam model
	E39-S53 (stainless steel type)	
Pin-hole Slit for Through-beam Sensor	E39-S48 (sealed tape type)	2-mm dia., 1-mm dia., and 0.5-mm dia. slits are sold in pairs, one each for the receiver and emitter of a through-beam model
	E39-S54 (stainless steel type)	
Filter for Mutual Interference Prevention (for Through-beam Sensor)	E39-E8	4 filters are sold together for two through-beam models (2 filters each for the emitters and receivers)

E3S-A/E3S-B Sensor Accessories

Name	Model	Remarks
Mini-reflector	E39-R4	One
Small Reflector	E39-R3	One
Reflector Tape	E39-RSA, -RSB	One (sealed type)

Specifications

Model	E3S-A			
	Without self-diagnostic functions			
Sensing method	Through-beam, Retroreflective (polarized)	Diffuse reflective: 10 cm	Diffuse reflective: 20 cm	Diffuse reflective: 70 cm
NPN output	E3S-AT11, -AR11 E3S-AT16, -AR16 E3S-AT61, -AR61 E3S-AT66, -AR66	E3S-AD13 E3S-AD63 E3S-AD18 E3S-AD68	E3S-AD11 E3S-AD16 E3S-AD61 E3S-AD66	E3S-AD12 E3S-AD17 E3S-AD62 E3S-AD67
PNP output	E3S-AT31, -AR31 E3S-AT36, -AR36 E3S-AT81, -AR81 E3S-AT86, -AR86	E3S-AD33 E3S-AD83 E3S-AD38 E3S-AD88	E3S-AD31 E3S-AD36 E3S-AD81 E3S-AD86	E3S-AD32 E3S-AD37 E3S-AD82 E3S-AD87
Wavelength of LED light source	700 nm (red)	880 nm (infrared)	700 nm (red)	880 nm (infrared)
Sensitivity adjustment	Two-turn (endless) sensitivity adjustor with indicator			
Self-diagnostic functions	---			
Timer	---			
Turbo function	---			
Method of connection	Prewired/connector			
Weight	Prewired type: 60 g; connector type: 11 g			
Operation mode	Dark-ON or Light-ON (switchable)			
Output	Open collector current output (NPN or PNP)			
Circuit protection	Load short-circuit protection, reverse connection protection, mutual interference prevention (except for through-beam models)			
Indicators	Light indicator (red) and stability indicator (green); emission indicator (red) for the emitter of through-beam models			
Materials	Case: Polybutylene terephthalate Lens: Denaturated polyallylate Mounting bracket: Stainless steel (SUS304)			
Attachments	Mounting bracket, sensitivity adjustor knob, screws, sensitivity adjustor cover, close-mounting plate (only for Sensors with connector terminals) and reflector (E39-R1: only for retroreflective Sensors)			

Model	E3S-A				E3S-B
	With self-diagnostic functions (timer and turbo)				Through-beam, Retroreflective (polarized), Diffuse reflective
Sensing method	Through-beam, Retroreflective (polarized)	Diffuse reflective: 10 cm	Diffuse reflective: 20 cm	Diffuse reflective: 70 cm	
NPN output	E3S-AT21, E3S-AR21, E3S-AT71, E3S-AR71	E3S-AD23, E3S-AD73	E3S-AD21, E3S-AD71	E3S-AD22, E3S-AD72	E3S-BT11, -BR11, E3S-BD11, -BT61, E3S-BR61, -BD61
PNP output	E3S-AT41, E3S-AR41, E3S-AT91, E3S-AR91	E3S-AD43, E3S-AD93	E3S-AD41, E3S-AD91	E3S-AD42, E3S-AD92	E3S-BT31, -BR31, E3S-BD31, -BT81, E3S-BR81, -BD81
Wavelength of LED light source	700 nm (red)	880 nm (infrared)	700 nm (red)	880 nm (infrared)	700 nm (red)
Sensitivity adjustment	Two-turn (endless) sensitivity adjustor with indicator				One-turn sensitivity adjustor with indicator
Self-diagnostic functions	Self-diagnostic output, External diagnostic input	Self-diagnostic output			---
Timer	0 to 100 ms OFF-delay variable adjustor				---
Turbo function	Yes (with turbo switch)			---	---
Method of connection	Prewired				
Weight	60 g				56 g
Operation mode	Dark-ON or Light-ON (switchable)				Dark-ON or Light-ON (wire-selectable)
Output	Open collector current output (NPN or PNP)				
Circuit protection	Load short-circuit protection, reverse connection protection, mutual interference prevention (except for through-beam models) functions				
Indicators	Light indicator (red) and stability indicator (green); emission indicator (red) for the emitter of the through-beam model				
Materials	Case: Polybutylene terephthalate Lens: Denaturation polyallylate Mounting bracket: Stainless steel (SUS304)				
Attachments	Mounting bracket, sensitivity adjustor knob, screws, sensitivity adjustor cover, close-mounting plate (only for Sensors with connector terminals) and reflector (E39-R1: only for retroreflective Sensors)				Mounting bracket, sensitivity adjustor knob, screws, sensitivity adjustor cover, close-mounting plate and reflector (E39-R1: only for retroreflective Sensors)

■ Ratings/Characteristics

E3S-A General-purpose Sensors

Item		Through-beam	Retroreflective (polarized)	Diffuse reflective		
		E3S-AT11, 16, 21, 31, 36, 41, 61, 66, 71, 81, 86, 91	E3S-AR11, 16, 21, 31, 36, 41, 61, 66, 71, 81, 86, 91	E3S-AD23, 43, 73, 93	E3S-AD13, 18, 33, 38, 63, 68, 83, 88	E3S-AD11, 16, 21, 31, 36, 41, 61, 66, 71, 81, 86, 91
Power supply voltage		10 to 30 VDC, ripple: 10% max.				
Current consumption		40 mA max. (emitter and receiver) plus approx. 15 mA with turbo function	30 mA max. plus approx. 15 mA with turbo function	35 mA max.	30 mA max. plus approx. 15 mA with turbo function	35 mA max.
Rated sensing distance	White mat paper	0 to 7 m	0.1 to 2 m	0.1 to 10 cm	0.1 to 20 cm	0 to 70 cm
	Black mat paper	0 to 7 m	0.1 to 2 m	0.3 to 2.5 cm	0.5 to 2.3 cm	0.15 to 33 cm
Standard sensing object (white mat paper)		7 mm min.	30 mm min.	10 x 10 cm		20 x 20 cm
Variation in sensing distance		---		30%/ _{-0%} max.		
Hysteresis		---		20% max.	10% max.	20% max.
Sensing distance with attachment		E39-E6: 2.4 m 2-mm slit: 2.5 m 1-mm slit: 1.1 m 0.5-mm slit: 0.5 m	E39-R3: 10 to 130 cm E39-R4: 7 to 60 cm E39-RSA: 10 to 60 cm E39-RSB: 10 to 30 cm	---		
Min. sensing object		without slit: 2.0 mm 2-mm slit: 0.8 mm 1-mm slit: 0.4 mm 0.5-mm slit: 0.2 mm	E39-R1 Reflector: 10 mm E39-R3: 3 mm E39-R4: 1.0 mm	---		
Difference in direction between optical axis and mounting direction		±2° max. (checked along extended line in the mounting direction)		±2° max.		
Response time		0.5 ms max. for both operation and release				
Control output		30 VDC, 100 mA max. (residual voltage: 1 V max.) Open collector (residual voltage: 0.4 V max. at 16 mA)				
Self-diagnostic output		Only Sensors with self-diagnostic function: 50 mA max, 30 VDC (residual voltage: 1 V max.), open collector (residual voltage: 0.4 V max. 16 mA)				
External-diagnostic input	Input voltage	With emitter OFF: NPN: 0 V short-circuit or 1.5 V max. (push current: 1 mA max.) PNP: DC short-circuit or -1.5 VDC max. (pull current: 3 mA max.) With emitter ON: NPN/PNP Open (max. input voltage: 30 V max. with 0.1 mA current leakage)		---		
	Response time	0.5 ms max.				
Ambient illumination		Incandescent lamp: Illumination on optical spot: 5,000 lx max. Sunlight: Illumination on optical spot: 10,000 lx max.				
Ambient temperature		Operating: -25°C to 55°C (with no icing) Storage: -40°C to 70°C (with no icing)				
Ambient humidity		Operating: 35% to 85% Storage: 35% to 95%				
Insulation resistance		20 MΩ min. (at 500 VDC)				
Dielectric strength		1,000 VAC, 50/60 Hz for 1 min				
Vibration resistance		Destruction: 10 to 55 Hz, 1.5-mm double amplitude (30G) 2 hrs each in three directions				
Shock resistance		Destruction: Approx. 50G, 3 times each in three directions				
Enclosure ratings		IEC: IP67; NEMA: 4X				

E3S-B Miniature Sensors

Item		Through-beam	Refle reflective (polarized)	Diffuse reflective
		E3S-BT11, 31, 61, 81	E3S-BR11, 31, 61, 81	E3S-BD11, 31, 61, 81
Power supply voltage		12 to 24 VDC \pm 10%; ripple: 10% max.		
Current consumption		35 mA max. (emitter and receiver)	25 mA max.	
Rated sensing distance	White mat paper	0 to 2 m	0.1 to 1 m	0 to 20 cm
	Black mat paper	0 to 2 m	0.1 to 1 m	0.2 to 6 cm
Standard sensing object (white mat paper)		5.5 mm min.	3 cm min.	10 x 10 cm
Variation in sensing distance		---		30%/ _{-0%} max.
Hysteresis		---		20% max.
Sensing distance with attachment		E39-E8: 0.6 m 2-mm slit: 1 m 1-mm slit: 0.5 m 0.5-mm slit: 0.25 m 2-mm dia. slit: 0.6 m 1-mm dia. slit: 0.17 m 0.5-mm dia. slit: 0.04 m	E39-R3: 10 to 60 cm E39-R4: 7 to 35 cm E39-RSA: 10 to 20 cm E39-RSB: 10 to 30 cm	---
Min. sensing object		without slit: 2 mm 2-mm slit: 0.8 mm 1-mm slit: 0.4 mm 0.5-mm slit: 0.25 mm 2-mm dia. slit: 0.7 mm 1-mm dia. slit: 0.4 mm 0.5-mm dia. slit: 0.2 mm	E39-R1: 9 mm E39-R3: 2.5 mm E39-R4: 1.0 mm	---
Difference in direction between optical axis and mounting direction		\pm 2° max. (checked along the extended line in the mounting direction)		\pm 2° max.
Response time		0.5 ms max. for both operation and release		
Control output		26.4 VDC, 100 mA max. (residual voltage: 1 V max.); Open collector (residual voltage: 0.4 V max. at 16 mA)		
Ambient illumination		Incandescent lamp: Illumination on optical spot: 5,000 lx max. Sunlight: Illumination on optical spot: 10,000 lx max.		
Ambient temperature		Operating: -25°C to 55°C (with no icing) Storage: -40°C to 70°C (with no icing)		
Ambient humidity		Operating: 35% to 85% Storage: 35% to 95%		
Insulation resistance		20 M Ω min. (at 500 VDC)		
Dielectric strength		1,000 VAC, 50/60 Hz for 1 min		
Vibration resistance		Destruction: 10 to 55 Hz, 1.5-mm double amplitude (30G) 2 hrs each in three directions		
Shock resistance		Destruction: Approx. 50G, 3 times each in three directions		
Enclosure ratings		IEC: IP67; NEMA: 4X		

Engineering Data

■ E3S-A Type

**Parallel Operating Range (Typical)
E3S-ATj 1**

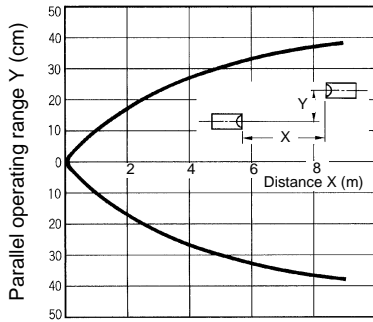

**Operating Range (Typical)
E3S-ADj (Left and Right)**

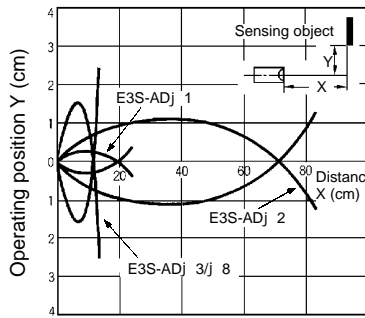

E3S-ADj (Up and Down)

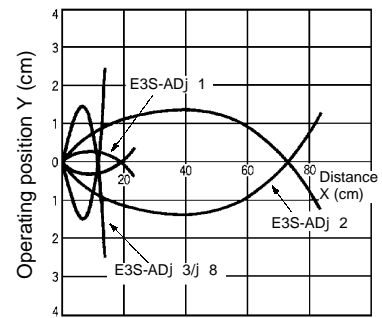

**Sensing Distance vs. Object Size
E3S-ADj**

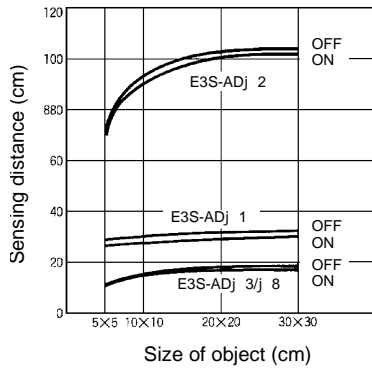

**Reflector Parallel Movement
(Typical) E3S-ARj 1**

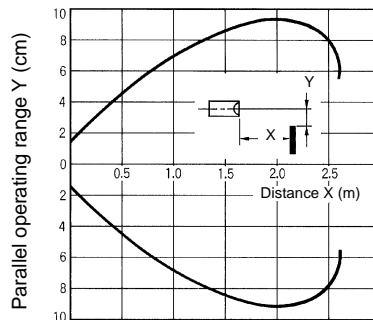

**Excess Gain vs. Set Distance
(Typical) E3S-ATj 1**

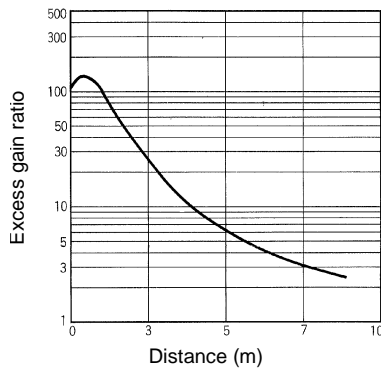

E3S-ADj 1, -ADj 2, -ADj 3, -ADj 8 (Detection of White Paper) E3S-ADj 1, -ADj 2, -ADj 3, -ADj 8 (Detection of Black Paper)

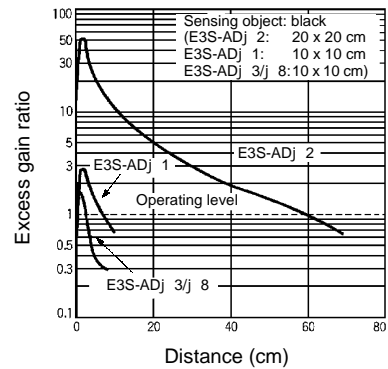
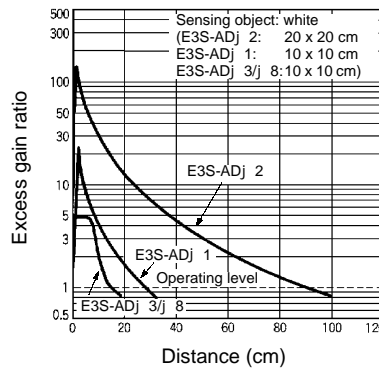

E3S-ARj 1 (With Reflector: E39-R1)

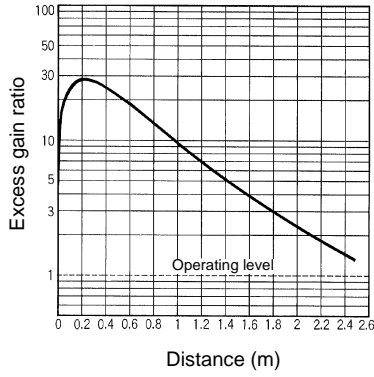

■ E3S-B Type

**Parallel Operating Range (Typical)
E3S-BTj 1 (Left and Right)**

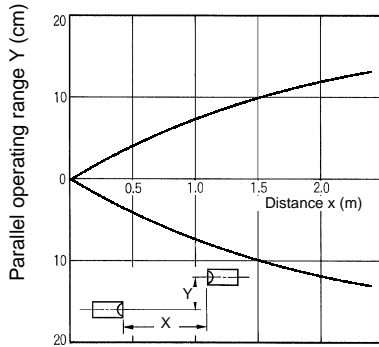

E3S-BTj 1 (Up and Down)

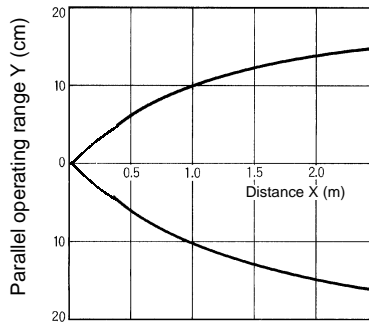

E3S-BDj 1 (Left and Right)

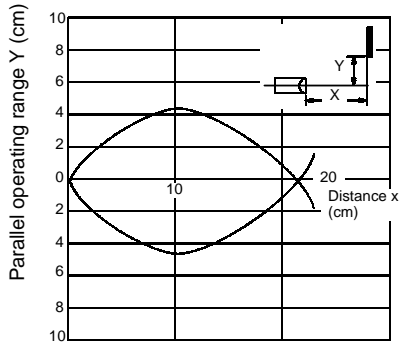

E3S-BDj 1 (Up and Down)

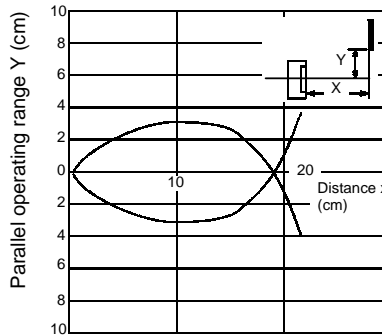

Reflector Parallel Operating Range (Typical)
E3S-BRj 1

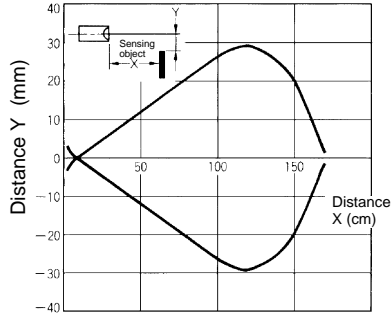

Sensing Distance vs. Set Distance (Typical) E3S-BD11

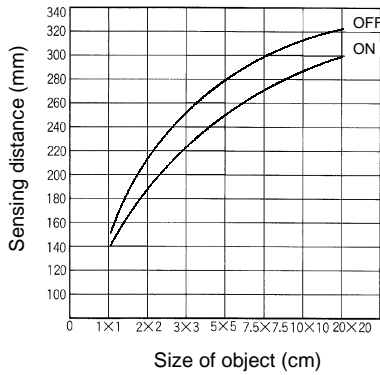

Excess Gain vs. Set Distance (Typical) E3S-BTj 1

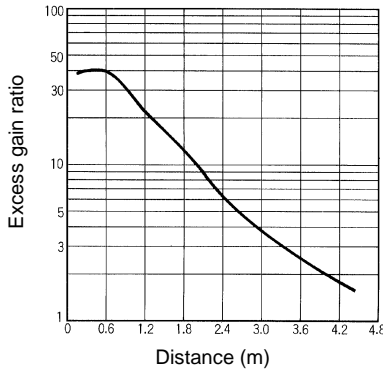

E3S-BRj 1 (With Reflector: E39-R1)

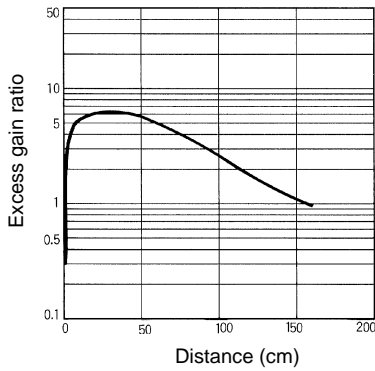

E3S-BDj 1 (Detection of White Paper)

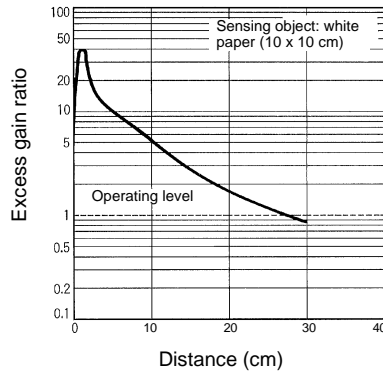

E3S-BDj 1 (Detection of Black Paper)

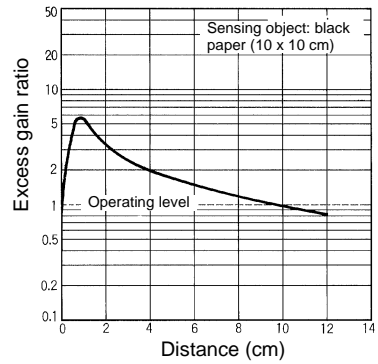

Operation

■ Replacing the E3H with the E3S-B

The following is the conversion table for changing from the E3H to the E3S-B.

Models

Old models	New models
E3H-1C1, E3H-1C2	E3S-BT11
E3H-1C13, E3H-1C23	E3S-BT61
E3H-DS5C1, E3H-DS5C2	E3S-BD11
E3H-DS5C13, E3H-DS5C23	E3S-BD61

Comparison

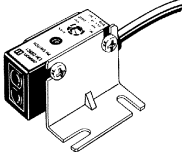
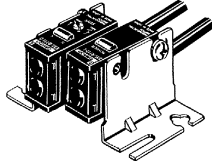
Item		E3H	E3S-B
Appearance			
Sensing distance		Through-beam: 1 m Diffuse reflective: 5 cm	Through-beam: 2 m Diffuse reflective: 20 cm
Response time		Through-beam: 4 ms Diffuse reflective: 3 ms	Through-beam: 0.5 ms Diffuse reflective: 0.5 ms
Enclosure rating		IP65	IP67
Selection of operation mode (see note)		3 exclusive cables each for dark-ON and light-ON (different part No.)	With common lead wires (to be re-connected for mode selection) (4 cables)
LED for emitter		Infrared	Red
Indicator		Light indicator (red)	Light indicator (red) Stability indicator (green)
Mounting		Two M3 holes	One M3 hole
Mounting pitch * (see note)		Through-beam: 16 mm Reflective: 20 mm	16 mm for both through-beam and reflective models (same as that of the E3H with the mounting bracket)
Dimensions * (see note)	Through-beam	Horizontal: 12 x 15 x 29 mm Vertical: 12 x 12 x 25 mm	10 x 16 x 28 mm
	Reflective	Horizontal: 12 x 15 x 33 mm Vertical: 12 x 12 x 29 mm	
Difference in direction of optical axis		---	Coincides with the mounting bracket (attachments) (approx. 1 mm without mounting bracket)
Difference in direction between optical axis and mounting direction		Not specified	±2° max.
Variation in sensing distance		Not specified	Reflective: +30%/-0% max.
Mounting bracket		Iron	Stainless steel



Note: The items marked with an asterisk are particularly important when replacing the E3H with the E3S-B.

■ Replacing the E3S with the E3S-A

The following is the conversion table for when replacing the E3S with the E3S-A.

Old models	New models
E3S-2E4 E3S-2C4	E3S-AT11
E3S-2E41 E3S-2C41	E3S-AT61
E3S-2B4	E3S-AT31
E3S-2B41	E3S-AT81
E3S-DS10E4 E3S-DS10C4	E3S-AD12
E3S-DS10E41 E3S-DS10C41	E3S-AD62
E3S-DS10B4	E3S-AD32
E3S-DS10B41	E3S-AD82

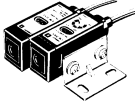
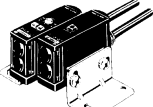
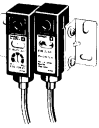
Comparison

Item	E3S (old model with plastic casing)	E3S-A
Appearance		
Sensing distance	Through-beam: 2 m Retroreflective: --- Diffuse reflective: 10 cm	Through-beam: 7 m Retroreflective: 2 m (MSR) Diffuse reflective: 70 cm (infrared) 20 cm (red)
Response time	Reflective: 1 ms max. Through-beam: 3 ms max.	0.5 ms max.
Enclosure rating	IP65 (mounting bracket: iron)	IP67 (mounting bracket: stainless steel)
Vertical operating panel with sensitivity adjustor (see note 1)	The sensitivity adjustor, indicators, and lenses are located on the same panel. 	The sensitivity adjustor and indicators are located on top of the model. 
Output	Voltage and current outputs	Open collector
Power supply voltage	12 to 24 VDC ±10%	10 to 30 VDC
LED for emitter	Infrared	Red (except for 70-cm type)
Sensitivity dispersion of diffuse reflective model	Not specified (approx. 150% max.)	30% max.
Difference in direction between optical axis and mounting direction	Not specified (approx. 12° max.)	±2° max.
Selection of operation mode* (see note 1)	Dark-ON and light-ON selectable by changing the polarity of the power cable.	Dark-ON and light-ON selectable with a selector.
Dimensions * (see note 1)	Through-beam: 18.8 x 15.4 x 40 mm Diffuse reflective: 21 x 15.4 x 40 mm	21 x 12 x 40 mm
Dimensions with Mounting Bracket * (see note 1)	Through-beam	Horizontal: The same as the height of the model (25.1 mm) Vertical: From the mounting holes of the mounting bracket (16 mm)
	Diffuse reflective	Horizontal: The same as the height of the model (27.3 mm) Vertical: From the mounting holes of the mounting bracket (16 mm)
Mounting Bracket	Iron	Stainless steel
Material (lens)	Polycarbonate	Deuterated polyallylate (U polymer)

Note: 1. The items marked with an asterisk are particularly important when replacing the E3S with the E3S-A.

2. When connecting the E3S-A to a timer or counter with voltage input terminals, be sure to connect a resistor between the output and positive power supply terminals (e.g., 4.7-kΩ resistor that withstands 1/4 W for a supply voltage of 12 VDC and 10-kΩ resistor that withstands 1/4 W for a supply voltage of 24 VDC), in which case the sensor may output a pulse signal the moment power is supplied to the E3S-A.

■ Output Circuits
E3S-A

Type	Model	Mode switch	Output transistor	Output circuit
NPN	E3S-AT11 E3S-AT16 E3S-AT61 E3S-AT66 E3S-AR11 E3S-AR16 E3S-AR61 E3S-AR66 E3S-AD13 E3S-AD63 E3S-AD18 E3S-AD68 E3S-AD11 E3S-AD16 E3S-AD61 E3S-AD66 E3S-AD12 E3S-AD17 E3S-AD62 E3S-AD67	Light ON	ON when light is received.	
		Dark ON	ON when light is not received.	
				<p>Connector Type</p> <p>Emitter</p> <p>Reflective/Receiver</p> <p>Pin No. 2 is open.</p>
	E3S-AT21 E3S-AT71 E3S-AD23 E3S-AD73 E3S-AD21 E3S-AD71 E3S-AD22 E3S-AD72	Light ON	ON when light is received.	
		Dark ON	ON when light is not received.	
	E3S-AR21 E3S-AR71	Light ON	ON when light is received.	
		Dark ON	ON when light is not received.	

Type	Model	Mode switch	Output transistor	Output circuit
PNP	E3S-AT31 E3S-AT36 E3S-AT81 E3S-AT86 E3S-AR31 E3S-AR36 E3S-AR81 E3S-AR86 E3S-AD33 E3S-AD83 E3S-AD38 E3S-AD88 E3S-AD31 E3S-AD36 E3S-AD81 E3S-AD86 E3S-AD32 E3S-AD37 E3S-AD82 E3S-AD87	Light ON	ON when light is received.	
		Dark ON	ON when light is not received.	
E3S-AT41 E3S-AT91 E3S-AD43 E3S-AD93 E3S-AD41 E3S-AD91 E3S-AD42 E3S-AD92	Light ON Dark ON	Light ON	ON when light is received.	
		Dark ON	ON when light is not received.	
E3S-AR41 E3S-AR91	Light ON Dark ON	Light ON	ON when light is received.	
		Dark ON	ON when light is not received.	

E3S-B

Type	Model	Connection method	Output transistor	Output circuit
NPN	E3S-BT11 E3S-BT61 E3S-BR11 E3S-BR61 E3S-BD11 E3S-BD61	Short-circuit the pink and the brown cords	ON when light is received.	<p>Emitter E3S-BT11/BT61</p>
		Short-circuit the pink and the blue cords, or open the pink cord	ON when light is not received.	<p>$Z_D : V_Z = 38 \text{ V}$</p>
PNP	E3S-BT31 E3S-BT81 E3S-BR31 E3S-BR81 E3S-BD31 E3S-BR81	Short-circuit the pink and the brown cords	ON when light is received.	<p>Emitter E3S-BT31/BT81</p>
		Short-circuit the pink and the blue cords, or open the pink cord	ON when light is not received.	<p>$Z_D : V_Z = 38 \text{ V}$</p>

■ Timing Charts

E3S-A









Type	Model	Mode switch	Output transistor	Timing chart		
NPN	E3S-AT11 E3S-AT16 E3S-AT61 E3S-AT66 E3S-AR11 E3S-AR16 E3S-AR61 E3S-AR66 E3S-AD13 E3S-AD63 E3S-AD18 E3S-AD68 E3S-AD11 E3S-AD16 E3S-AD61 E3S-AD66 E3S-AD12 E3S-AD17 E3S-AD62 E3S-AD67	Light ON	ON when light is received.	Light received Light not received		
		Dark ON	ON when light is not received.	Light received Light not received		
		Light ON	ON when light is received.	Light received Light not received T: Off-delay timer (0 to 100 ms)		
		Dark ON	ON when light is not received.	Light received Light not received T: Off-delay timer (0 to 100 ms)		
		PNP	E3S-AT31 E3S-AT36 E3S-AT81 E3S-AT86 E3S-AR31 E3S-AR36 E3S-AR81 E3S-AR86 E3S-AD33 E3S-AD83 E3S-AD38 E3S-AD88 E3S-AD31 E3S-AD36 E3S-AD81 E3S-AD86 E3S-AD32 E3S-AD37 E3S-AD82 E3S-AD87	Light ON	ON when light is received.	Light received Light not received
				Dark ON	ON when light is not received.	Light received Light not received
	E3S-AT41 E3S-AT91 E3S-AD43 E3S-AD93 E3S-AD41 E3S-AD91 E3S-AD42 E3S-AD92 E3S-AR41 E3S-AR91		Light ON	ON when light is received.	Light received Light not received T: Off-delay timer (0 to 100 ms)	
			Dark ON	ON when light is not received.	Light received Light not received T: Off-delay timer (0 to 100 ms)	

E3S-B

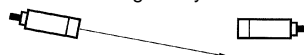
Type	Model	Connection method	Output transistor	Timing chart
NPN	E3S-BT11 E3S-BT61 E3S-BR11 E3S-BR61 E3S-BD11 E3S-BD61	Short-circuit the pink and the brown cords	ON when light is received.	Light received Light not received Light indicator (Red) ON OFF Output transistor ON OFF Load (relay) Operate Release (Between brown and black)
		Short-circuit the pink and the blue cords, or open the pink cord	ON when light is not received.	Light received Light not received Light indicator (Red) ON OFF Output transistor ON OFF Load (relay) Operate Release (Between brown and black)
PNP	E3S-BT31 E3S-BT81 E3S-BR31 E3S-BR81 E3S-BD31 E3S-BD81	Short-circuit the pink and the brown cords	ON when light is received.	Light received Light not received Light indicator (Red) ON OFF Output transistor ON OFF Load (relay) Operate Release (Between blue and black)
		Short-circuit the pink and the blue cords, or open the pink cord	ON when light is not received.	Light received Light not received Light indicator (Red) ON OFF Output transistor ON OFF Load (relay) Operate Release (Between blue and black)

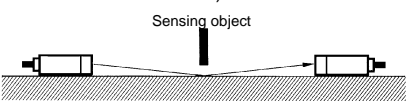
■ Self-diagnostic Function

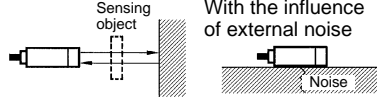
With this function, the E3S-A/B checks changes in environmental conditions (especially a change in the ambient temperature) and self-diagnoses the resistance against the changes. The result is shown by the indicators or an output signal.

Amount of incident light	Incident light indicator (red)	Indicator	Green indicator	Self-diagnostic function	Self-diagnostic example
1.2 or more	With light incident (red indicator: ON)	 Green Red	Stable operating state with incident light: Stable operation is expected in the rated temperature range with the green indicator ON.	---	---
1.0 to 1.2	Without light incident (red indicator: OFF)	 Green Red	Conditional operating state with incident light: Stable operation is expected if the temperature fluctuation is within $\pm 10\%$ of the primary temperature.	The self-diagnostic alarm output alerts the user to this state if it continues for 0.3 s.	<p>The optical axis misaligned by vibration.</p>  <p>Light decreased by dust.</p> 
0.8 to 1.0		 Green Red			<p>With light leakage (through-beam and retroreflective Sensors)</p>  <p>Light reflected from the floor or the background (diffuse reflective Sensors)</p>  <p>With the influence of external noise</p> 
0.8 or less		 Green Red	Stable operating state with no incident light: Stable operation is expected in the rated temperature range with the green indicator ON.	---	---

■ External Diagnostic Input Function

To switch the emission off, short-circuit the pink and the blue cords of the emitter of the E3S-ATj or the E3S-ARj with the NPN output feature. For the E3S-ATj or the E3S-ARj with the PNP output feature, short-circuit the pink and the brown cords.

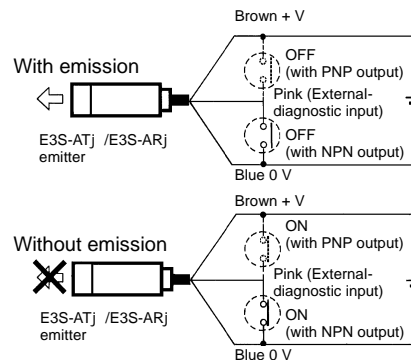

With this function, the operating status can be checked before operation.

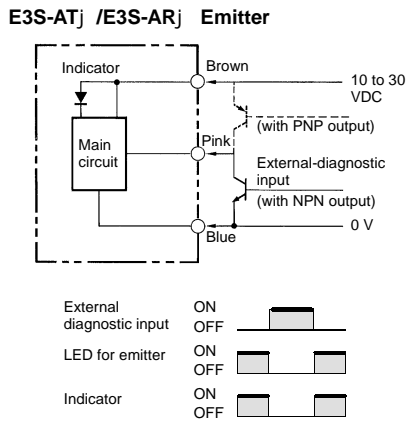

The sensor is normal if the control output varies when the self-diagnostic external input is ON and OFF. The sensor is abnormal if the control output does not vary when the self-diagnostic external input is turned ON or OFF.

Note: Before using the self-diagnostic external input function, the incident light beam to the sensor must not be blocked by an object.

■ Timer and Turbo Switch (Sensors with Self-diagnostic Output Function)

The E3S-A Sensor equipped with the self-diagnostic feature incorporates an OFF-delay timer that can be adjusted within a range of 0 to 100 ms.

The emitter of the through-beam sensor with the self-diagnostic feature incorporates a turbo switch. When this switch is on, the intensity of the red LED light source can be increased to make a brighter spot. The OFF-delay time adjuster of the retroreflective and the 20-cm diffuse reflective sensor is used as a turbo switch. When the adjuster is pressed, it functions as a turbo switch to automatically increase the power of the light source to create a brighter light spot. Do not press the adjuster when turning it.

■ Sensitivity Adjustment (Reflective Sensors)

Item	Position A	Position B	Setting
Sensing condition			---
Sensitivity adjustor			
Indicators	OFF STABILITY (green) ON LIGHT (red)	OFF STABILITY (green) OFF LIGHT (red)	OFF STABILITY (green) ON LIGHT (red)
Procedure	Locate a sensing object at the sensing distance, set the sensitivity adjustor to the minimum scale position, and gradually increase sensitivity by turning the sensitivity adjustor clockwise until the incident light indicator (red LED) is ON. Position A is where the indicator has turned ON. Regard the maximum scale position as Position A if the indicator does not turned ON at full sensitivity.	Remove the sensing object and gradually decrease sensitivity by turning the sensitivity adjustor counterclockwise from the maximum scale position until the incident light indicator (red LED) is OFF. Position B is where the indicator has turned off. Regard the minimum scale position as Position B if the indicator does not turned ON at minimum sensitivity.	Set the sensitivity indicator to the position between Positions A and B (in some cases, Positions A and B are opposite of the above example). The photoelectric sensor will then work normally if the stability indicator (green) is lit with and without the sensing object. If it is not lit, stable operation cannot be expected, in which case a different detection method must be applied.

Unlike conventional photoelectric sensors, the variation in the sensitivity of E3S photoelectric sensors is minimal. This means the sensitivity can be adjusted on only a single photoelectric sensor, and then the adjustors on the other photoelectric sensors can be set to the same scale position. There is no need to adjust the sensitivity of each photoelectric sensor individually.

■ Turbo Function (Turbo Switch)

With the turbo function switched ON, the light spot is visible even at a distance of 20 cm, making it easy to check the sensing position and the angle of the optical axis.

1. After using the turbo function, readjust the OFF-delay time that had been set, since the OFF-delay time could have been changed when the turbo switch (which is on the OFF-delay time adjuster) was pressed.

2. Press the OFF-delay time adjuster to switch ON the turbo function with a maximum force of 1 kg and within a maximum period of 3 min. (The photoelectric sensor, however, will not malfunction even if the turbo function is switched on for more than 3 min.)

With Turbo Switch ON

The turbo function is effective with the turbo switch pressed, and the function is reset automatically when released.



Normal Operating Condition

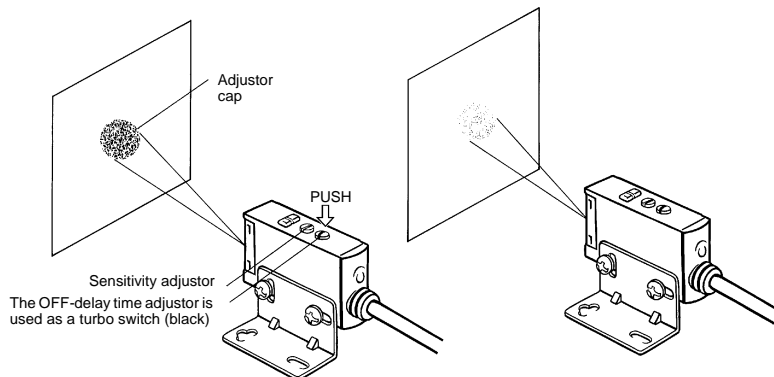

■ Operating Mode Selection

E3S-A

As shown in the following illustration, the E3S-A has an operating mode selector on the panel where the Receiver connector is located. With this operating mode selector, the E3S-A is in either dark-ON or light-ON mode.

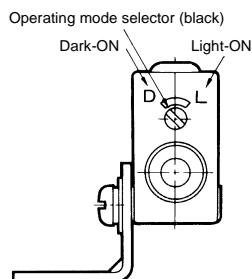

E3S-B

The operating mode of the E3S-B is determined with the connecting method of the Receiver cords as shown in the output circuit diagram on page 15.

Dimensions

Note: All units are in millimeters unless otherwise indicated.

■ E3S-A Prewired Sensors

E3S-AT11, E3S-AT31 (Receiver)

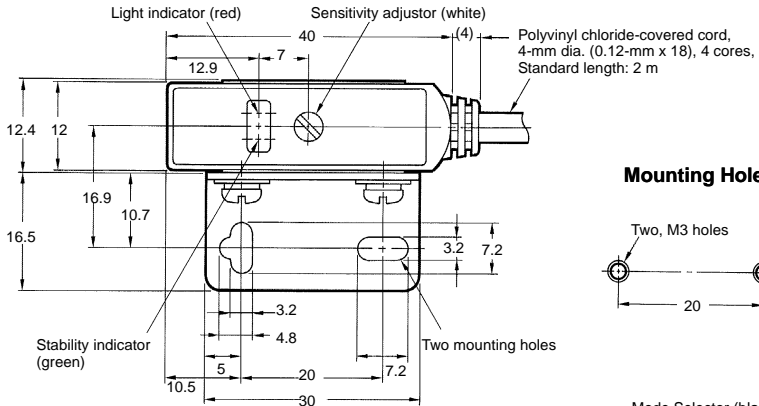
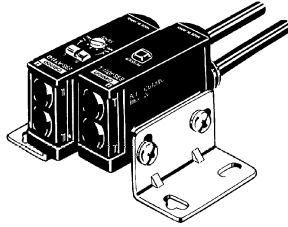

Mounting Holes

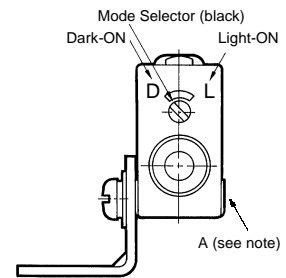
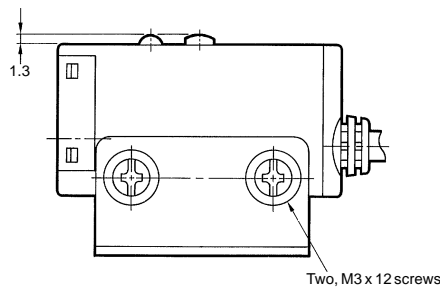
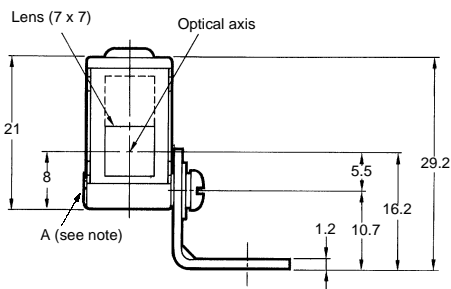
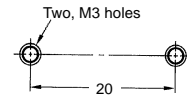

Note: The mounting bracket can be attached to side A.

E3S-AT11, E3S-AT31 (Emitter)

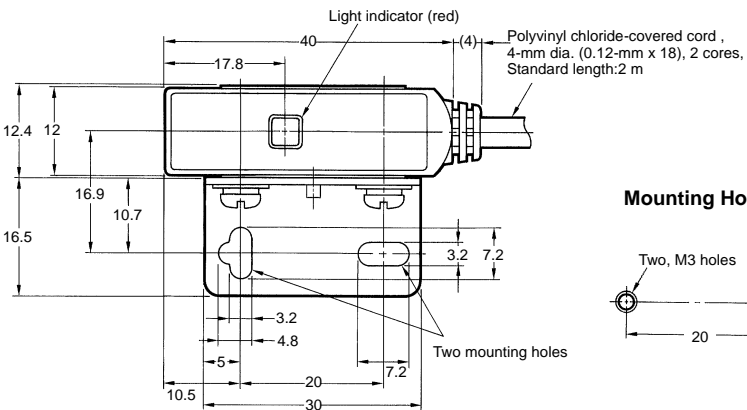

Mounting Holes

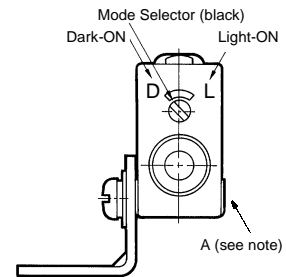
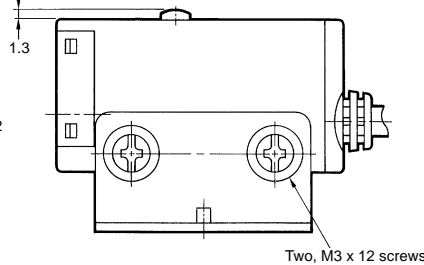
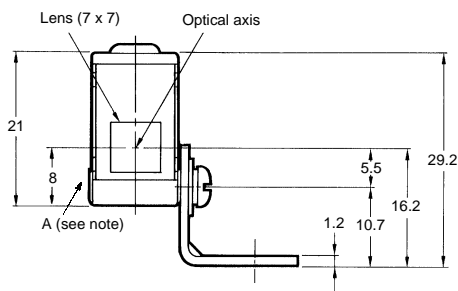
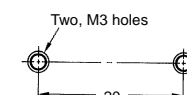

Note: The mounting bracket can be attached to side A.

**E3S-AT21, E3S-AT41
(Receiver)**

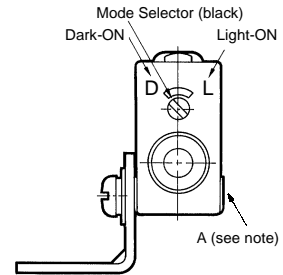
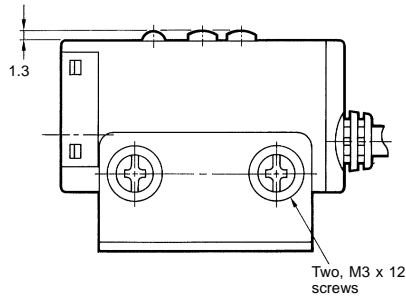
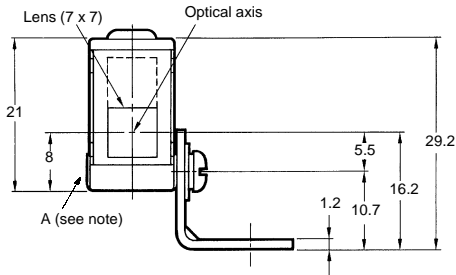
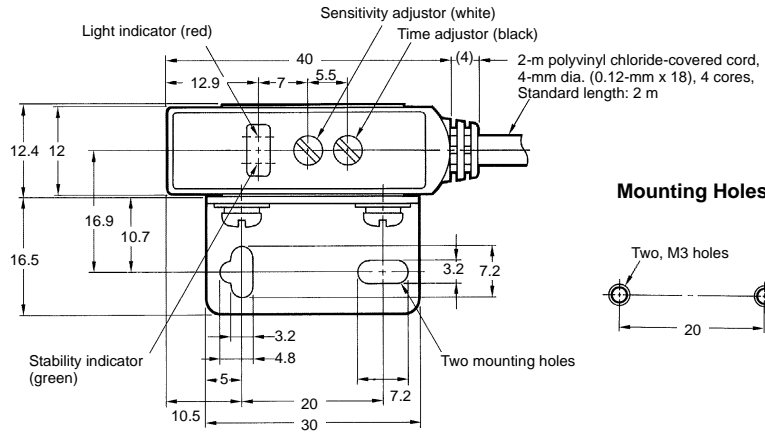
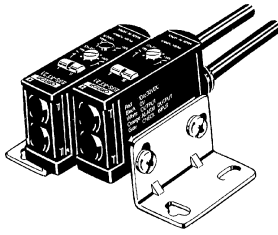

Note: The mounting bracket can be attached to side A.

**E3S-AT21, E3S-AT41
(Emitter)**

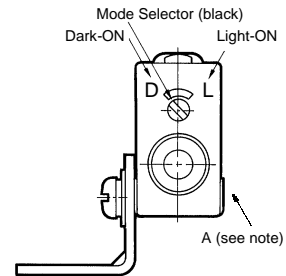
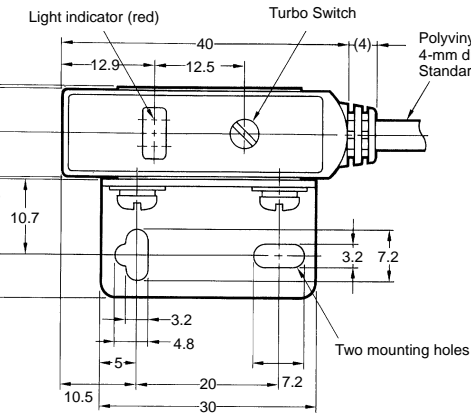
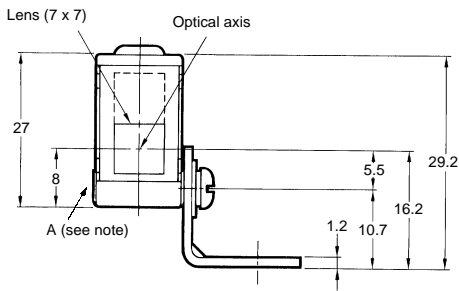

Note: The mounting bracket can be attached to side A.

Two, M3 x 12 screws

E3S-AR11, E3S-AR31
E3S-AR21, E3S-AR41

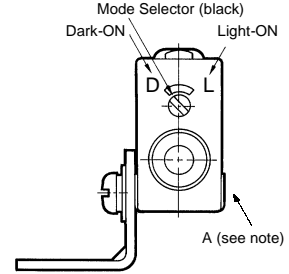
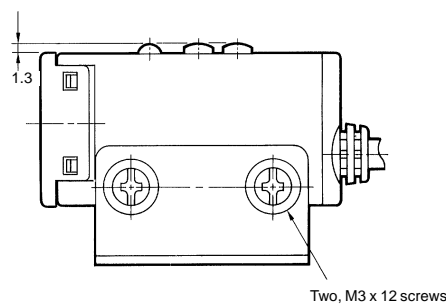
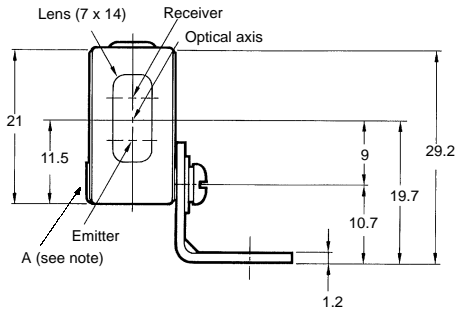
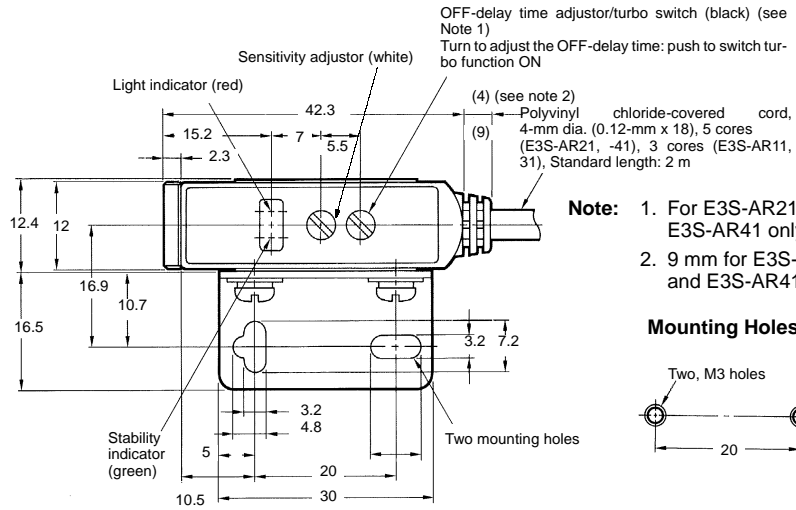
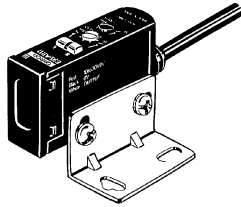

Note: The mounting bracket can be attached to side A.

E3S-AD11, E3S-AD31
E3S-AD13, E3S-AD31
E3S-AD12, E3S-AD32

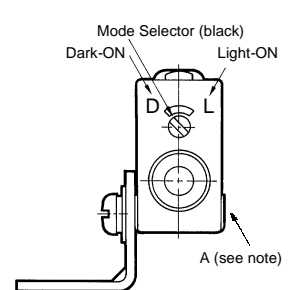
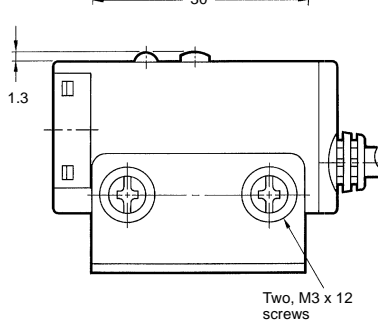
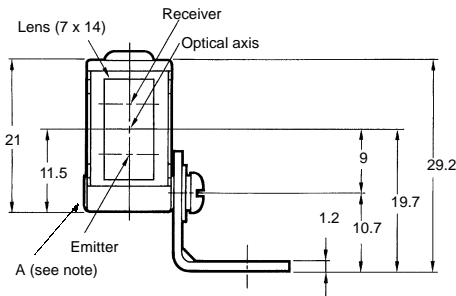
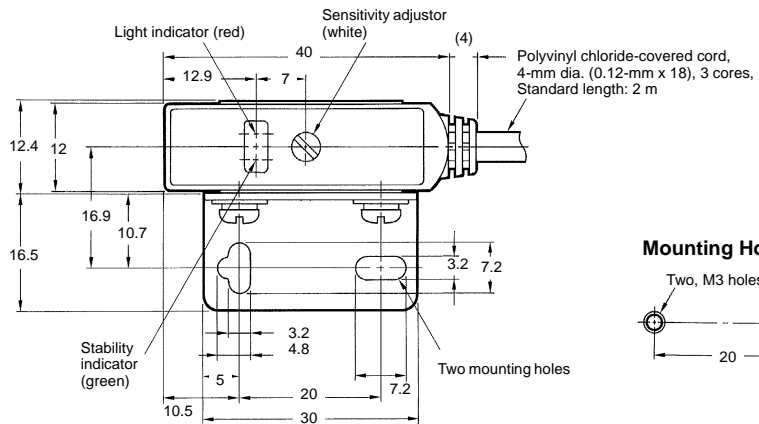
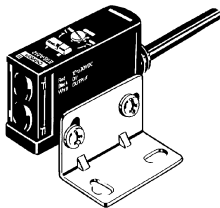

Note: The mounting bracket can be attached to side A.

E3S-AD21, E3S-AD41
E3S-AD23, E3S-AD43
E3S-AD22, E3S-AD42

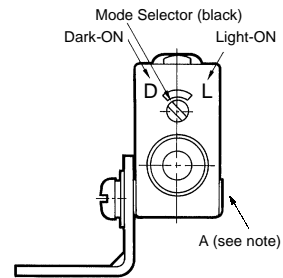
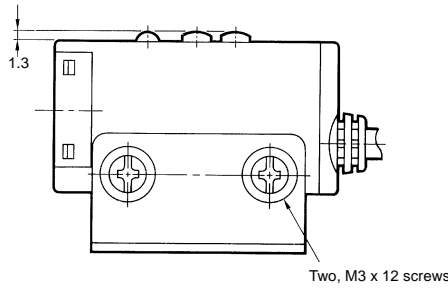
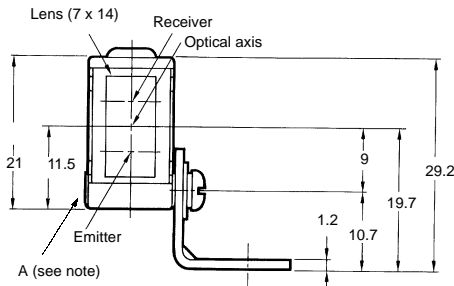
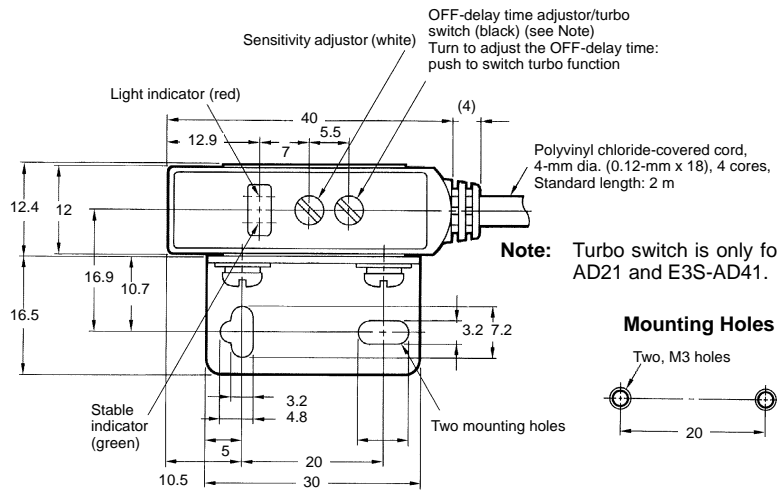
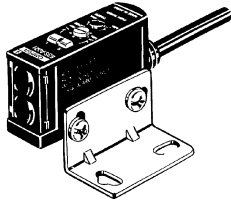

Note: The mounting bracket can be attached to side A.

E3S-AT61, E3S-AT81
(Receiver)

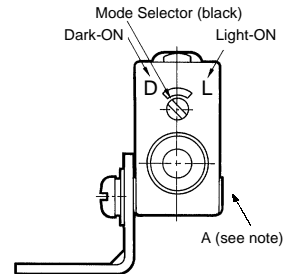
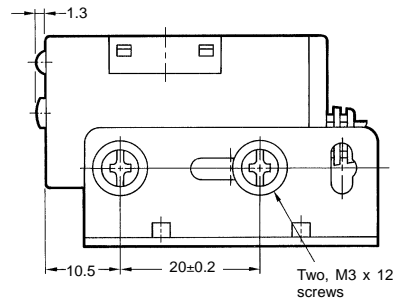
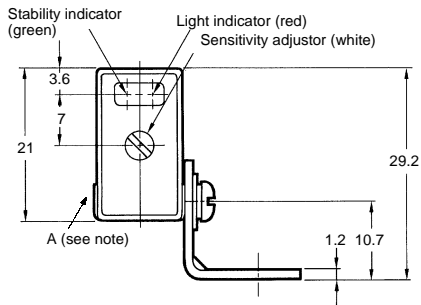
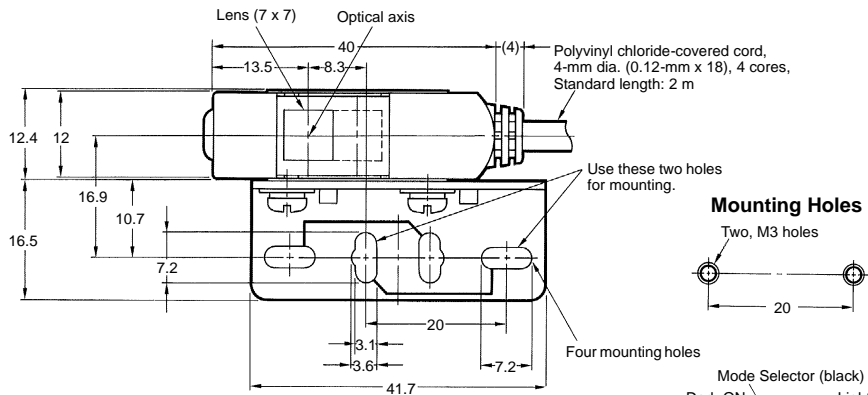
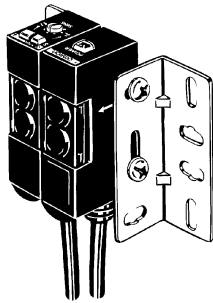

Note: The mounting bracket can be attached to side A.

**E3S-AT61, E3S-AT81
(Emitter)**

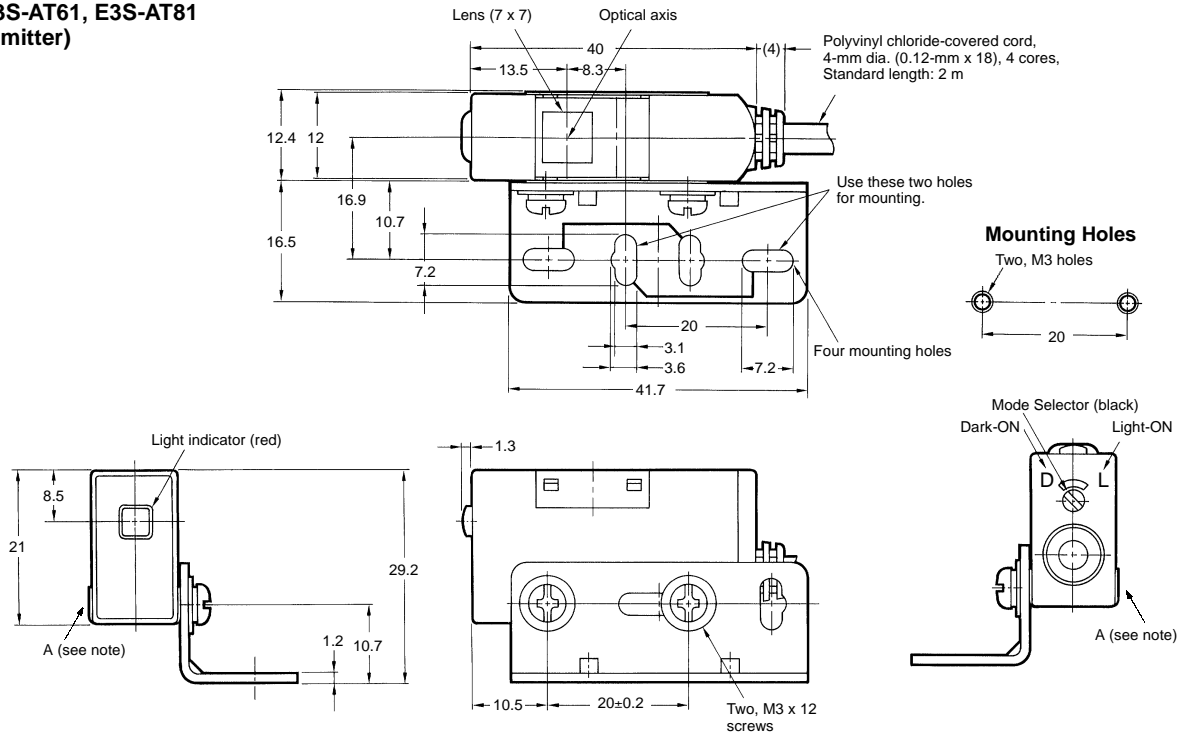

Note: The mounting bracket can be attached to side A.

**E3S-AT71, E3S-AT91
(Receiver)**

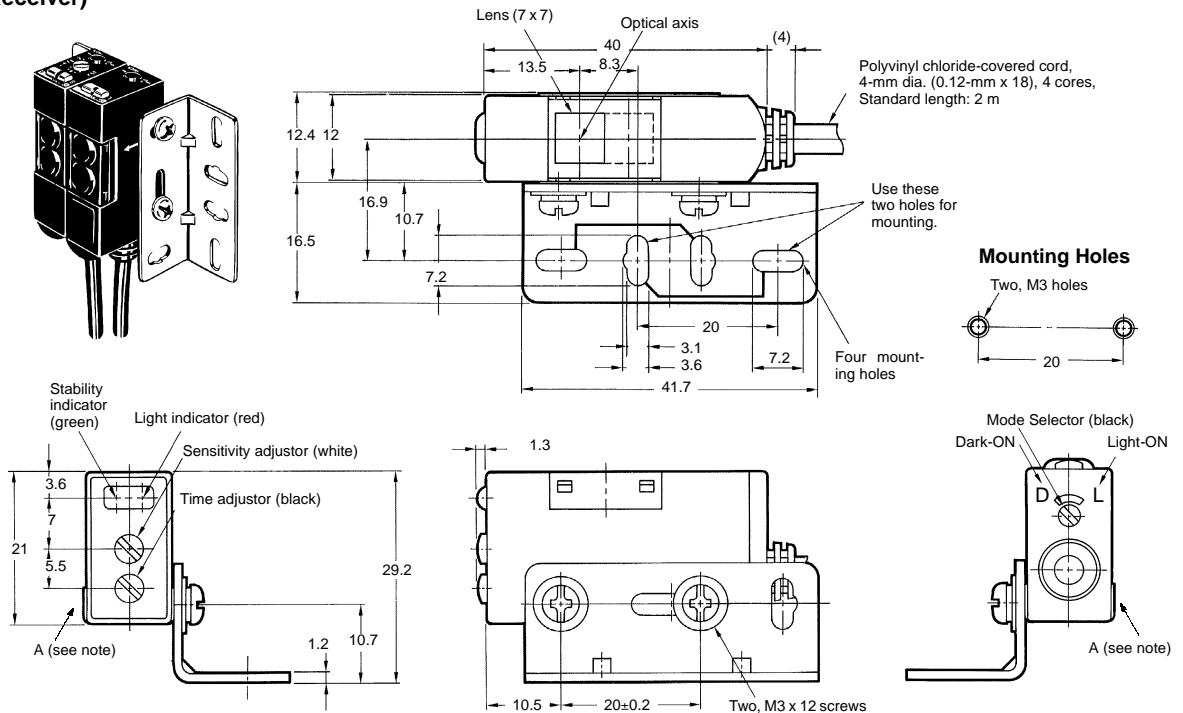

Note: The mounting bracket can be attached to side A.

**E3S-AT71, E3S-AT91
(Emitter)**

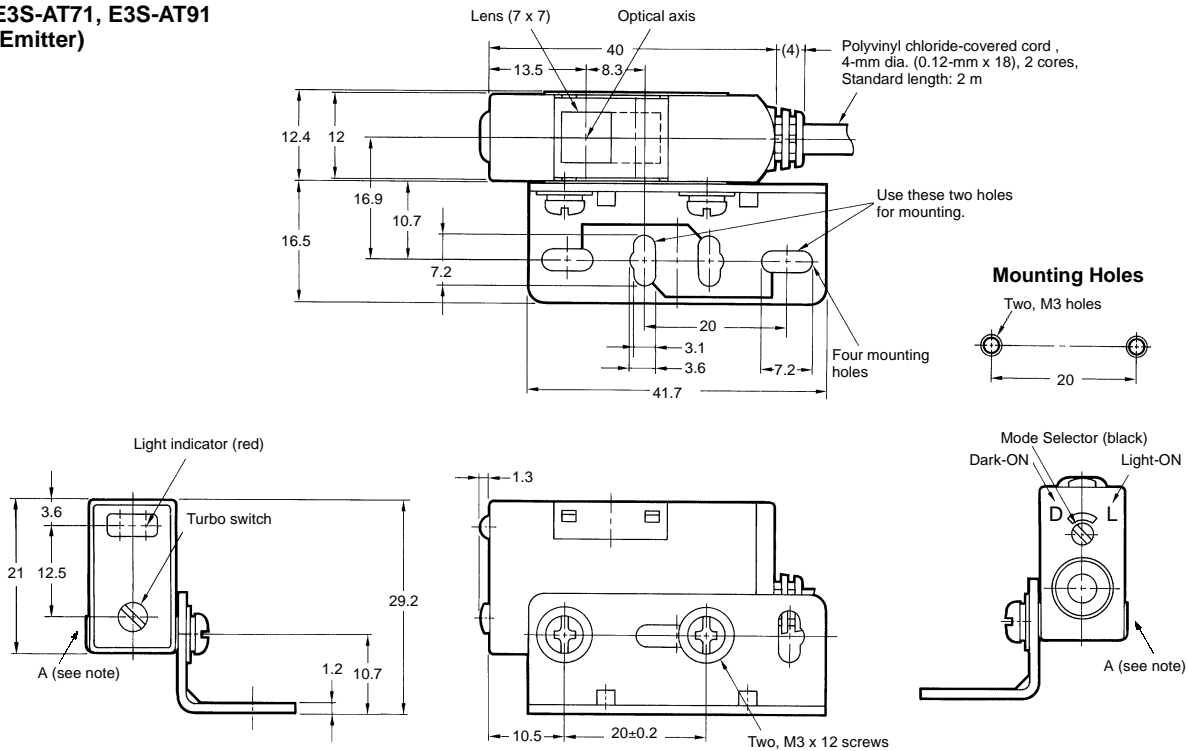

Note: The mounting bracket can be attached to side A.

**E3S-AR61, E3S-AR81
E3S-AR71, E3S-AR91**

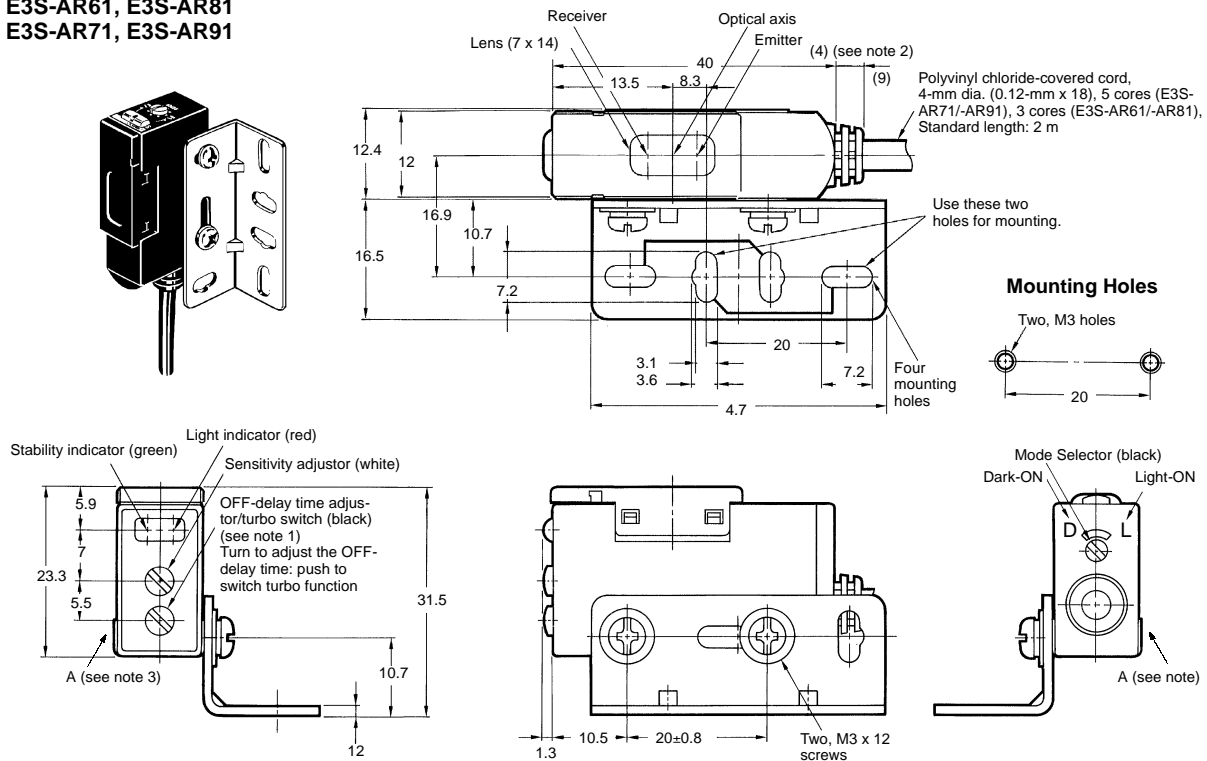

- Note:**
1. Turbo switch is only for E3S-AR71 and E3S-AR91.
 2. 9.7 mm for E3S-AR71/-AR91.
 3. The mounting bracket can be attached to side A.

E3S-AD61, E3S-AD81
E3S-AD63, E3S-AD83
E3S-AD62, E3S-AD82

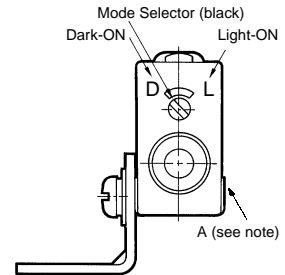
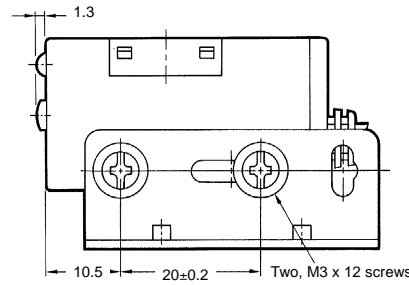
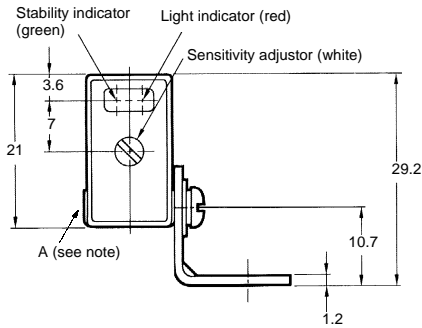
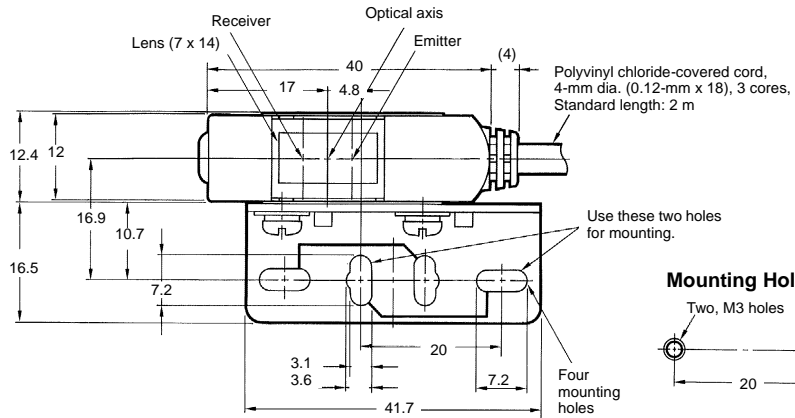
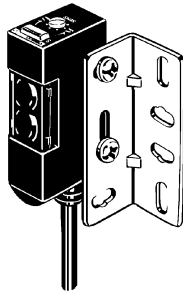

Note: The mounting bracket can be attached to side A.

E3S-AD71, E3S-AD91
E3S-AD73, E3S-AD93
E3S-AD72, E3S-AD92

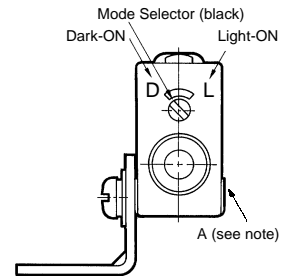
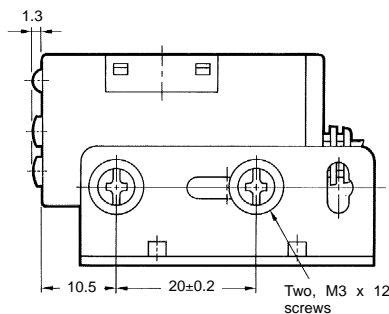
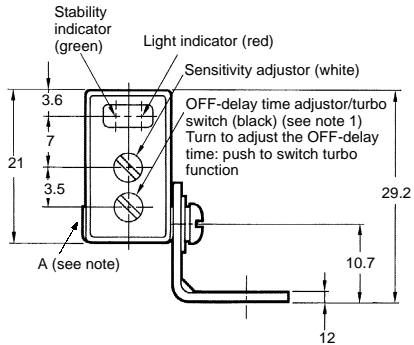
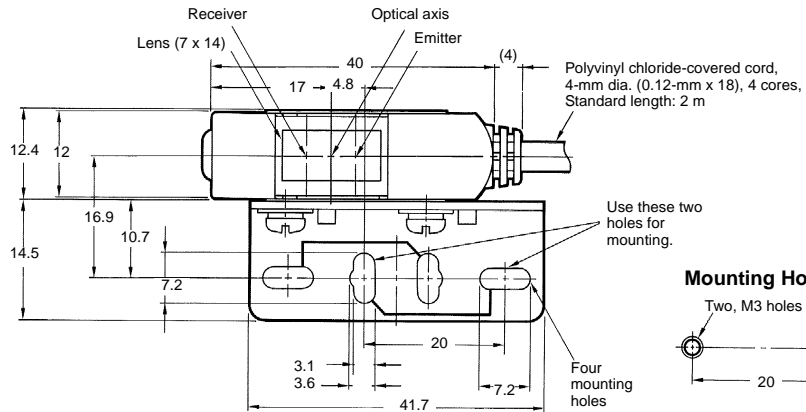
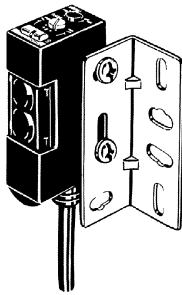

Note: 1. Turbo switch is only for E3S-AD71 and E3S-AD91.
 2. The mounting bracket can be attached to side A.

■ E3S-A Connector Type

E3S-AT16, E3S-AT36
(Receiver)

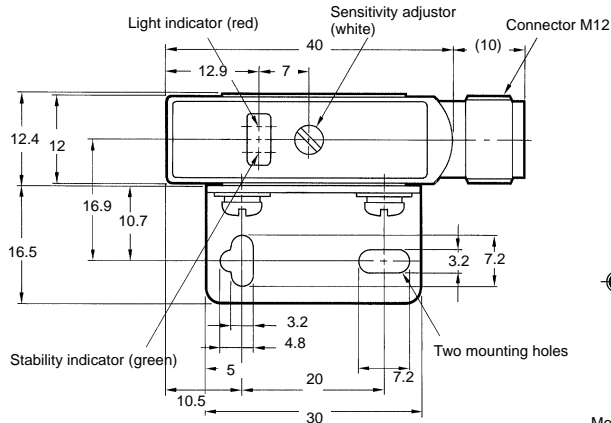
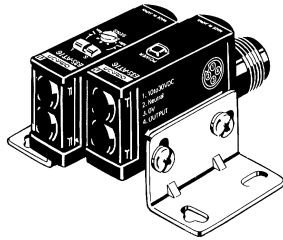

Mounting Holes

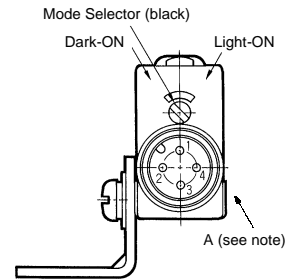
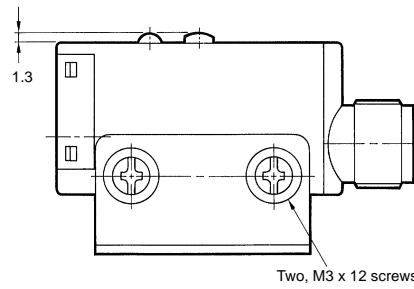
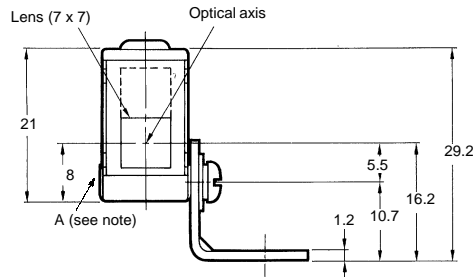
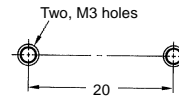

Note: The mounting bracket can be attached to side A.

E3S-AT16, E3S-AT36
(Emitter)

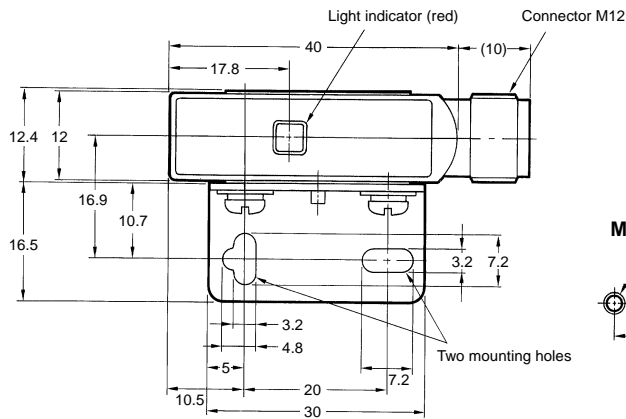

Mounting Holes

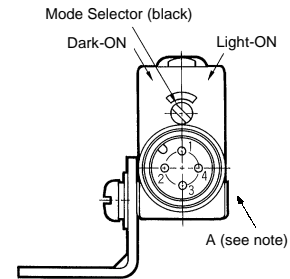
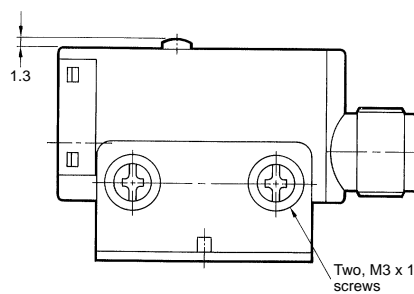
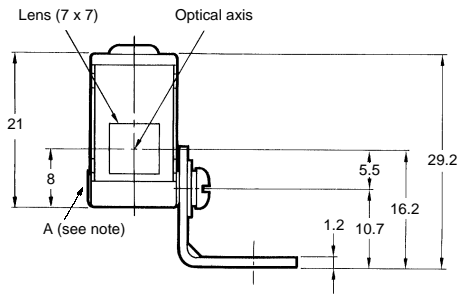
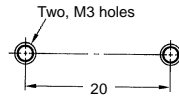

Note: The mounting bracket can be attached to side A.

E3S-AR16, E3S-AR36

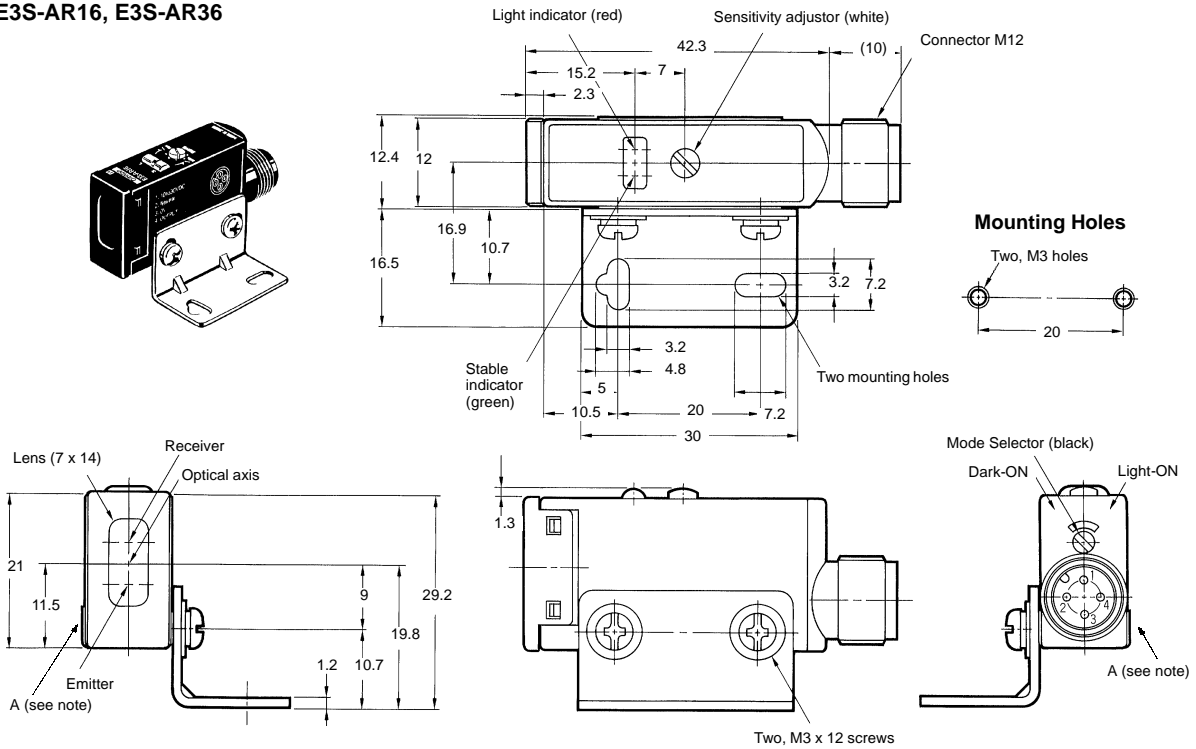

Note: The mounting bracket can be attached to side A.

E3S-AD16, E3S-AD36
E3S-AD18, E3S-AD38
E3S-AD17, E3S-AD37

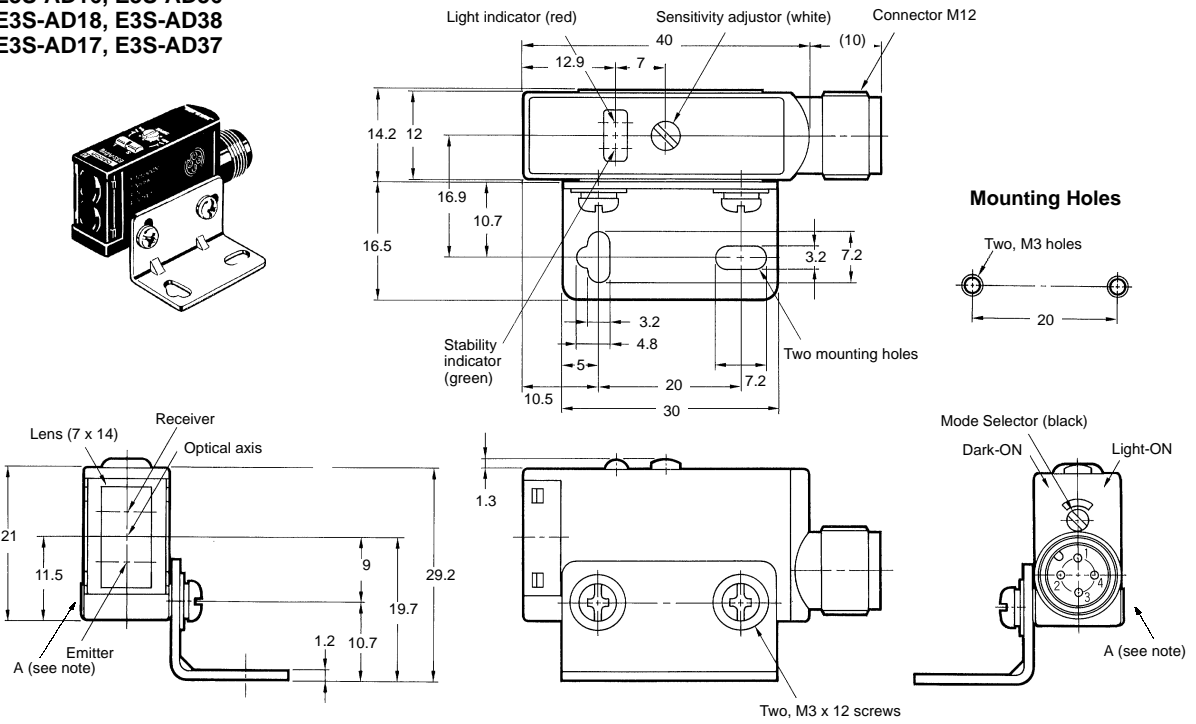

Note: The mounting bracket can be attached to side A.

**E3S-AT66, E3S-AT86
(Receiver)**

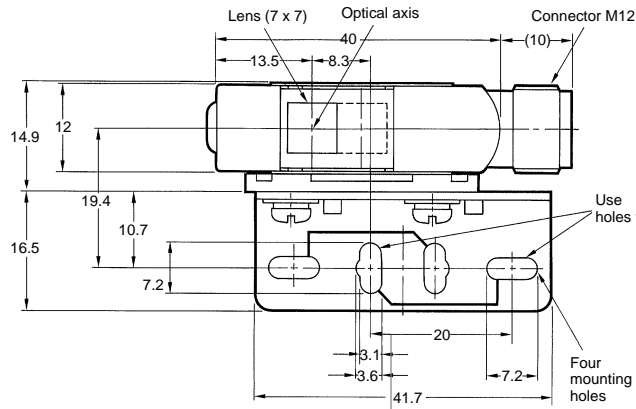
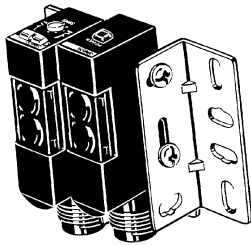

Mounting Holes

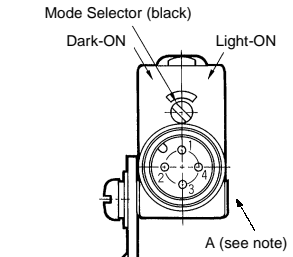
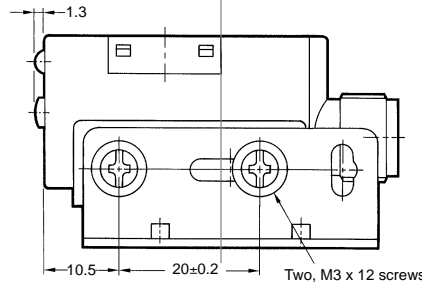
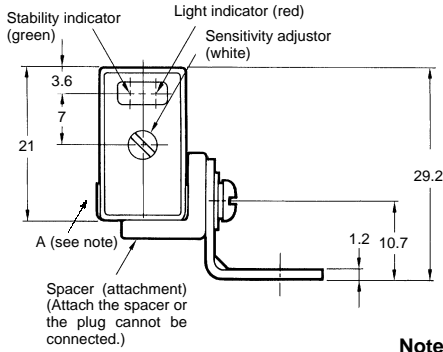
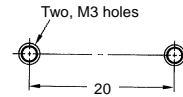

Note: The mounting bracket can be attached to side A.

**E3S-AT66, E3S-AT86
(Emitter)**

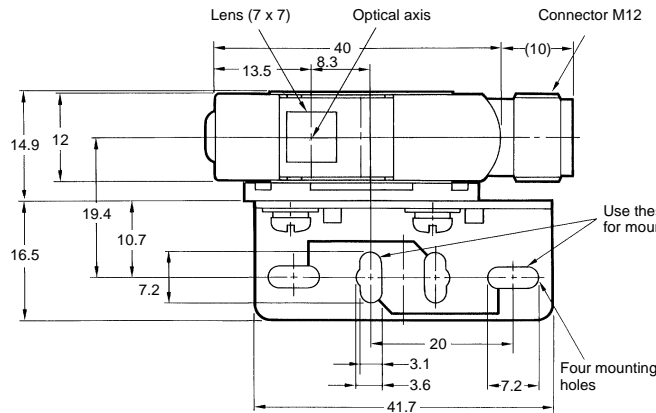

Mounting Holes

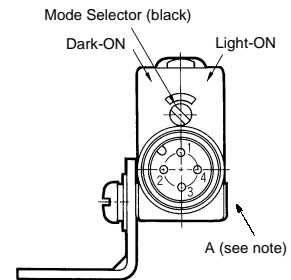
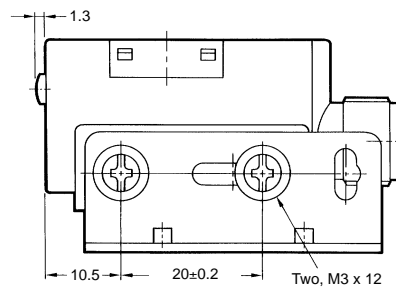
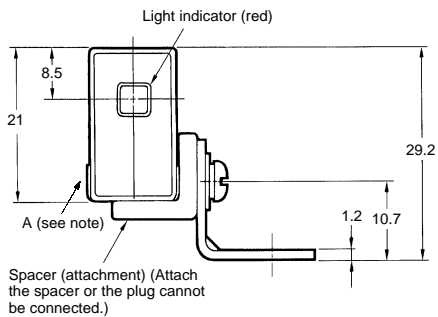
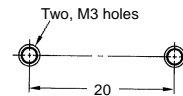

Note: The mounting bracket can be attached to side A.

E3S-AR66, E3S-AR86

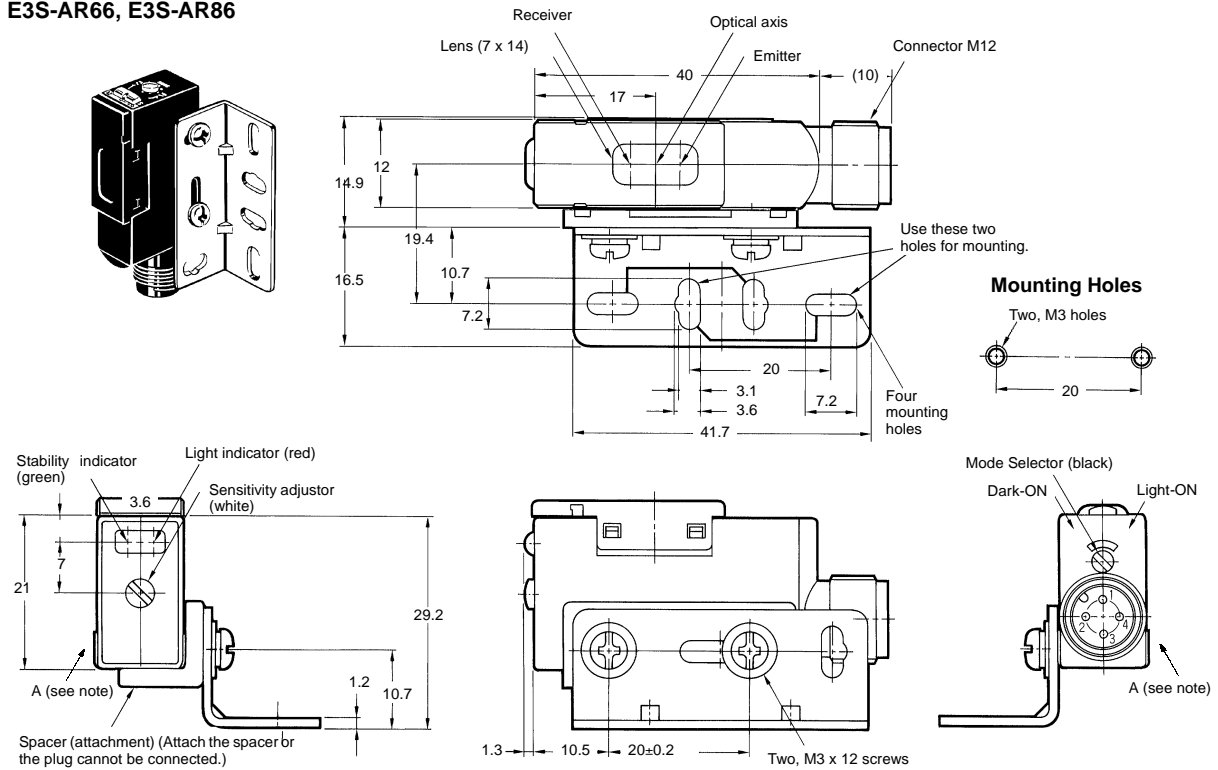

Note: The mounting bracket can be attached to side A.

E3S-AD66, E3S-AD86
E3S-AD68, E3S-AD88
E3S-AD67, E3S-AD87

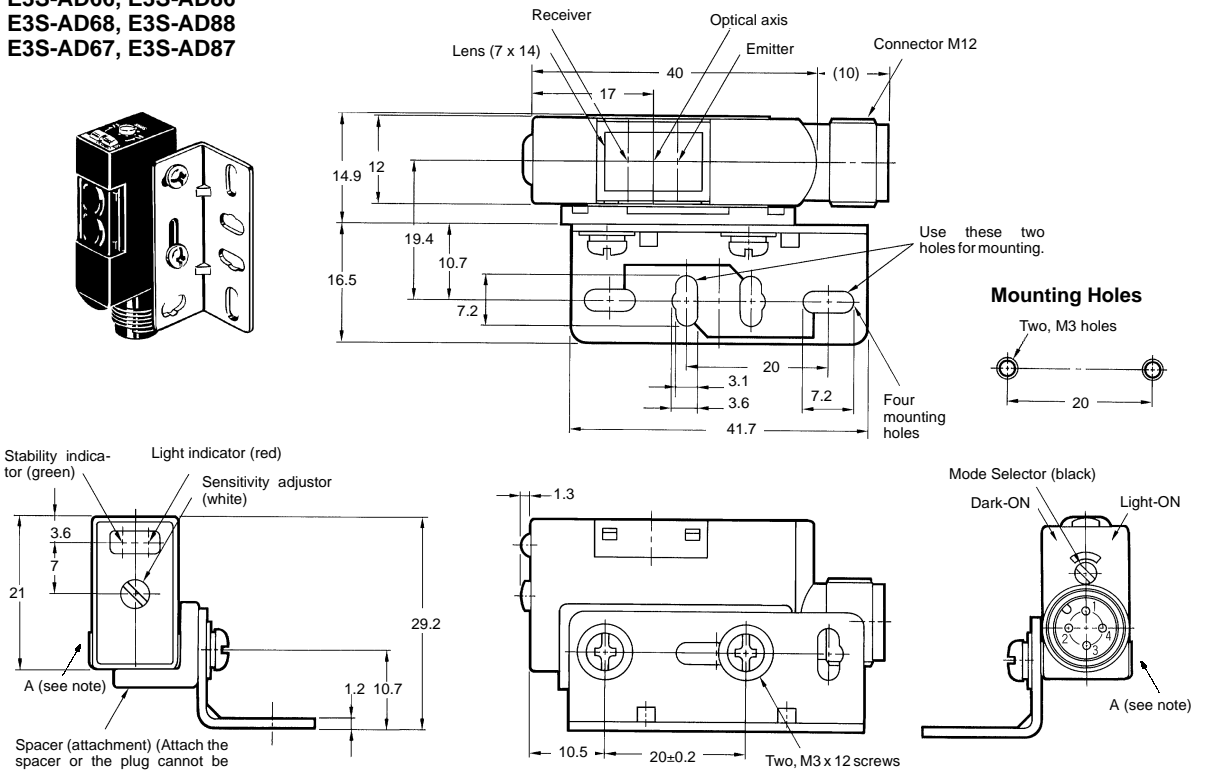

Note: The mounting bracket can be attached to side A.

■ E3S-B Lead Wire Output Type

E3S-BT11, E3S-BT31
(Receiver)

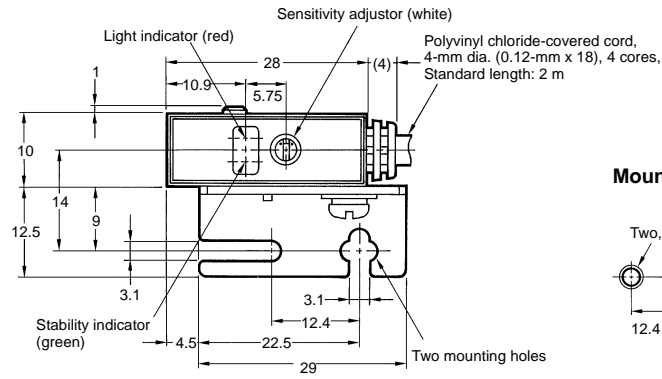
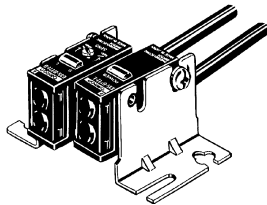

Mounting Holes

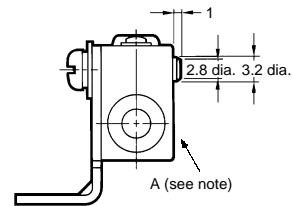
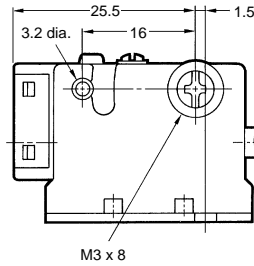
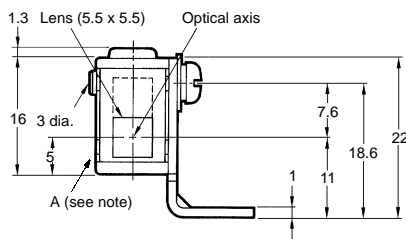
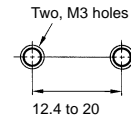

Note: The mounting bracket can be attached to side A.

E3S-BT11, E3S-BT31
(Emitter)

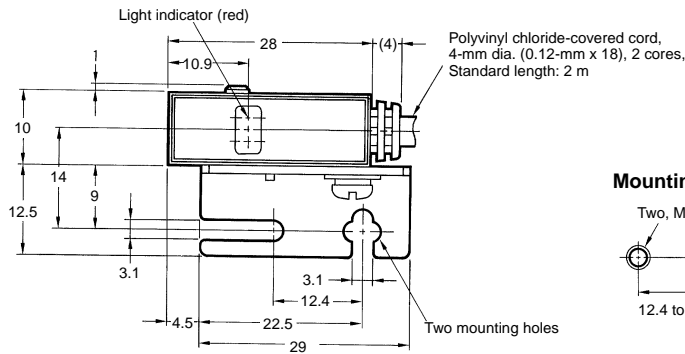

Mounting Holes

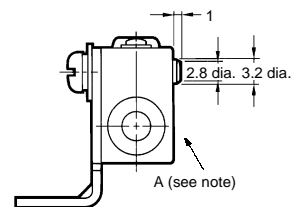
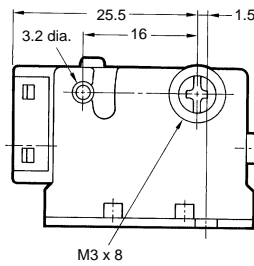
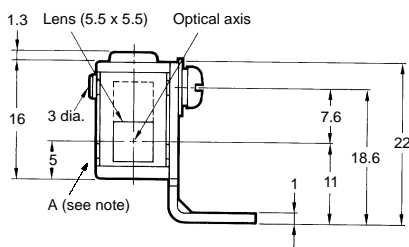
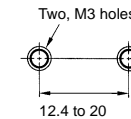

Note: The mounting bracket can be attached to side A.

E3S-BR11, E3S-BR31

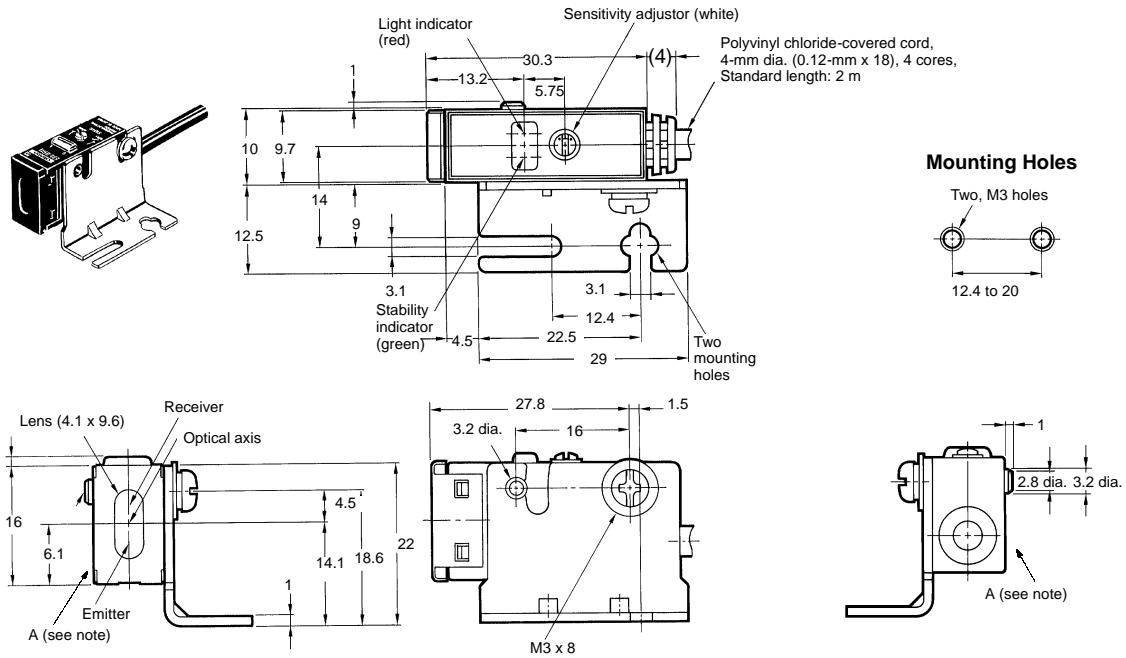

Note: The mounting bracket can be attached to side A.

E3S-BD11, E3S-BD31

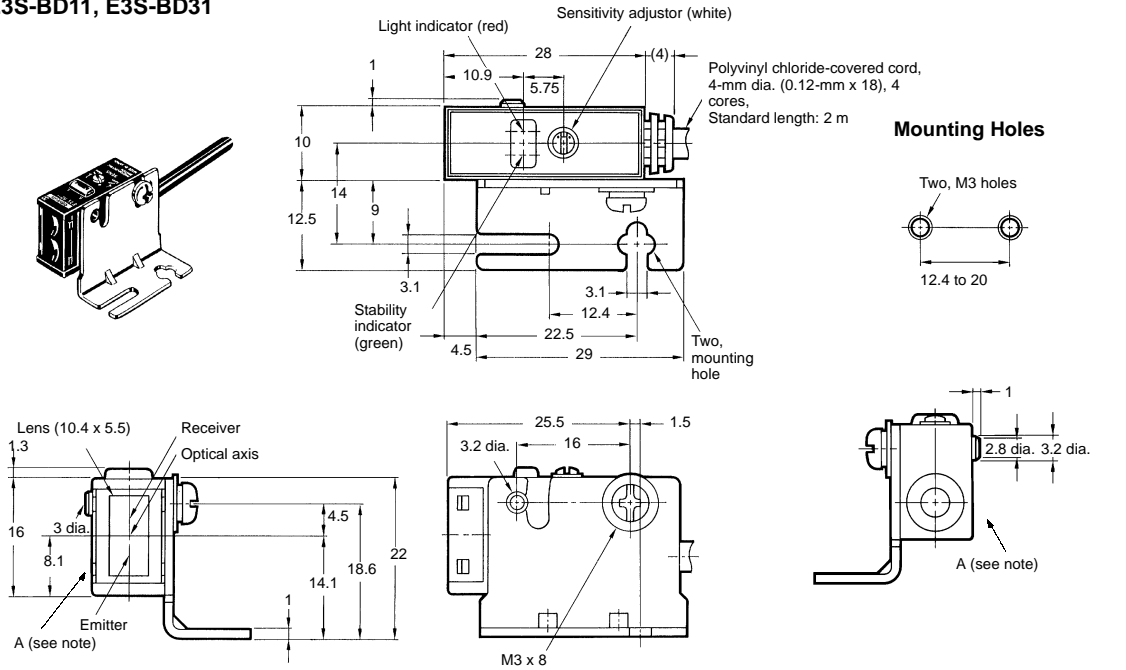

Note: The mounting bracket can be attached to side A.

**E3S-BT61, E3S-BT81
(Receiver)**

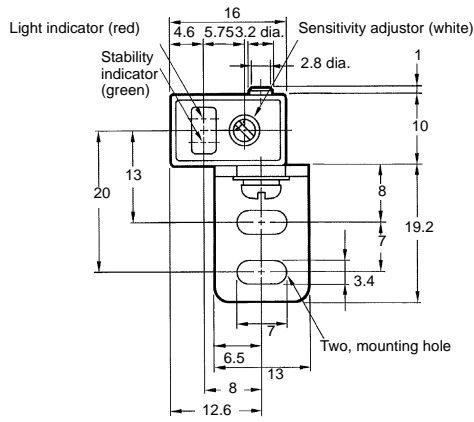
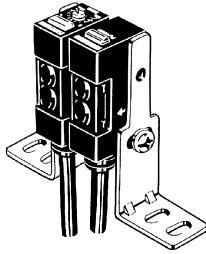

Mounting Holes

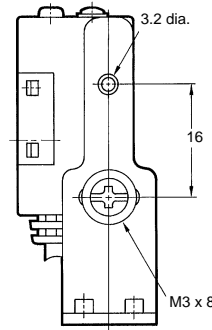
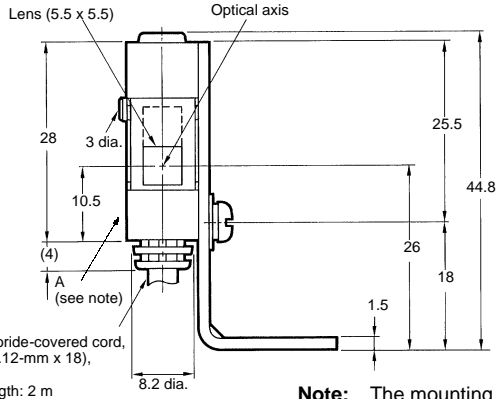
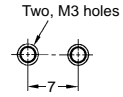

Note: The mounting bracket can be attached to side A.

**E3S-BT61, E3S-BT81
(Emitter)**

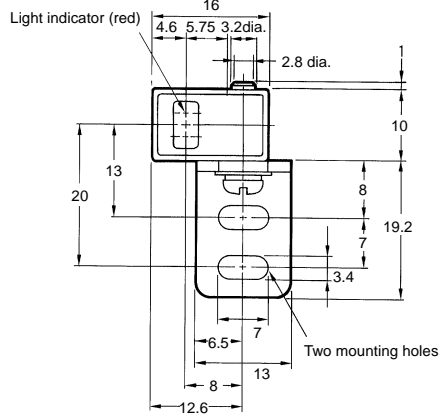

Mounting Holes

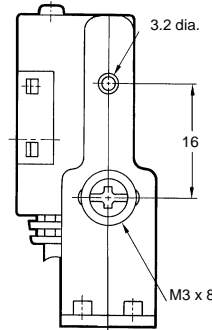
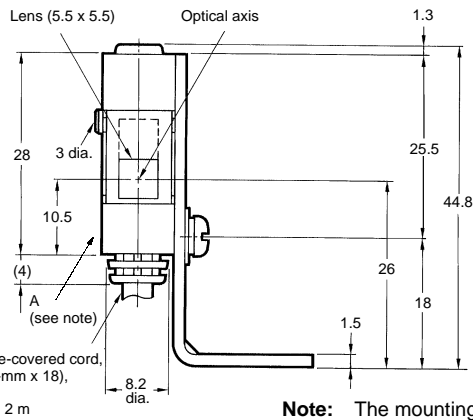
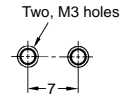

Note: The mounting bracket can be attached to side A.

E3S-BR61, E3S-BR81

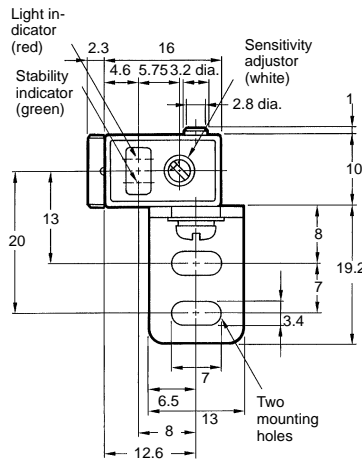
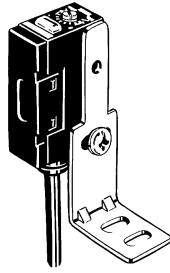

Mounting Holes

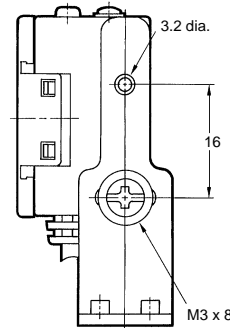
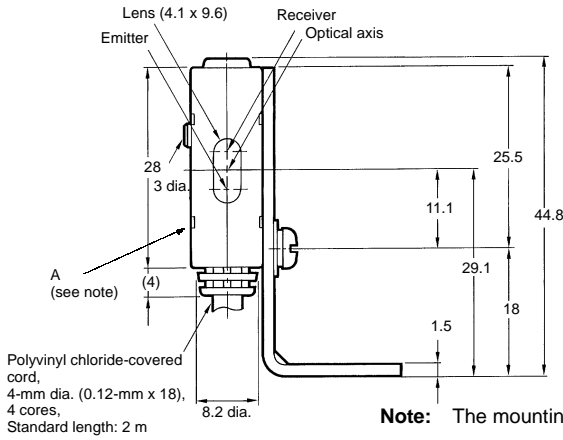
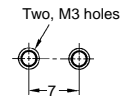

Note: The mounting bracket can be attached to side A.

E3S-BD61, E3S-BD81

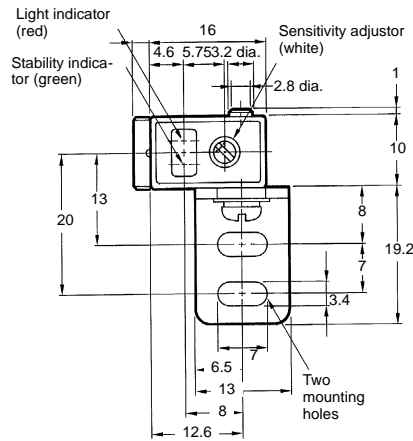
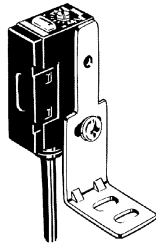

Mounting Holes

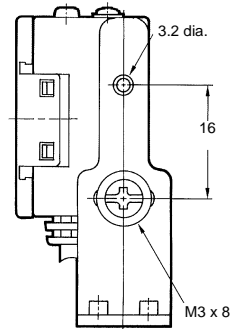
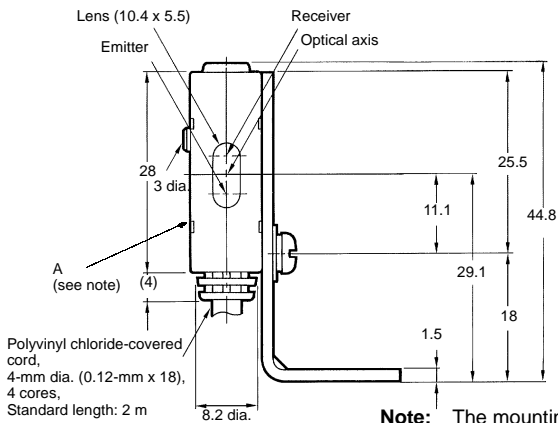
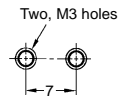

Note: The mounting bracket can be attached to side A.

■ Plug (for E3S-A Connector Type)

Straight Type
XS2F-D421-DC0-A

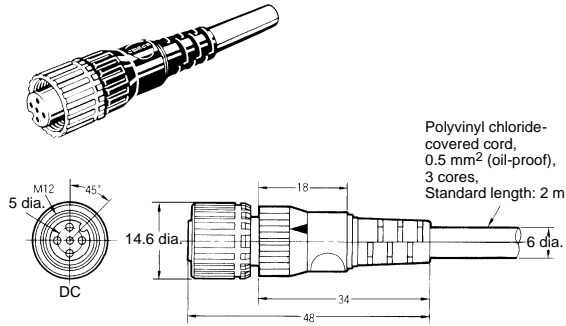

The XS2F-D421 Straight Cable Connector is also available. Refer to the output circuit diagram on page 13.

Cable drawing direction	No. of conductors	Cord length	Model
Straight	3	2 m	XS2F-D421-DC0-A
	4		XS2F-D421-D80-A
	3	5 m	XS2F-D421-GC0-A
	4		XS2F-D421-G80-A

■ Attachments

Standard Mounting Bracket
(for E3S-A Horizontal Sensor)
E39-L69

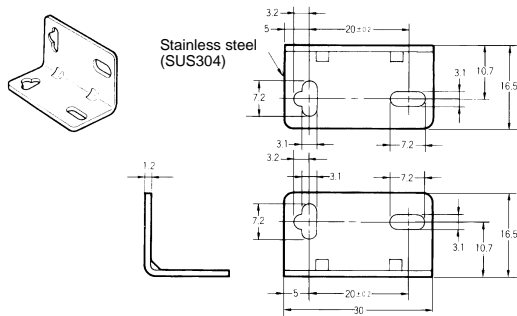

Standard Mounting Bracket
(for E3S-A Vertical Sensor) E39-L70

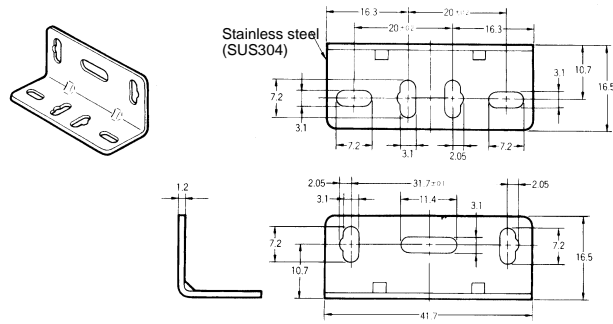

Standard Mounting Bracket
(for E3S-B Horizontal Sensor)
E39-L71

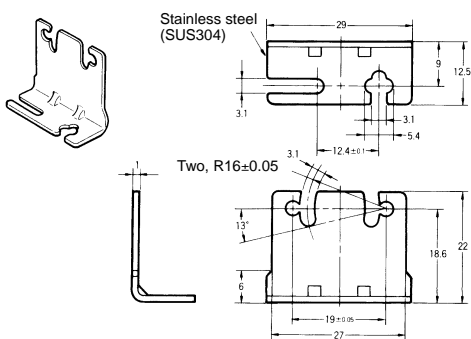

Standard Mounting Bracket
(for E3S-B Vertical Sensor) E39-L72

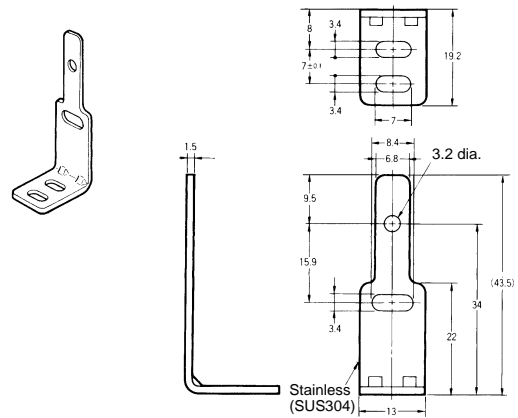

Close Mounting Plate (for E3S-A Connector Type) E39-L60

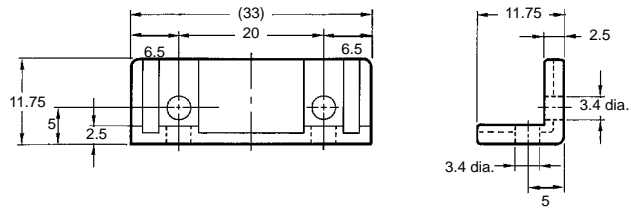
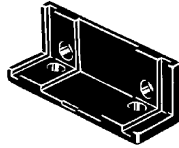

Close Mounting Plate (for E3S-B) E39-L61

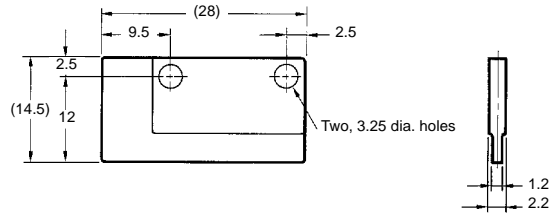
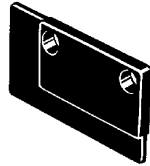

Sensitivity Adjustor Knob (for E3S-A) E39-G2

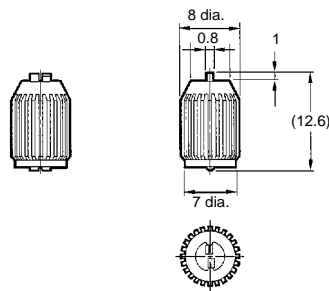

Retroreflector (Included with E3S-j Rj j) E39-R1

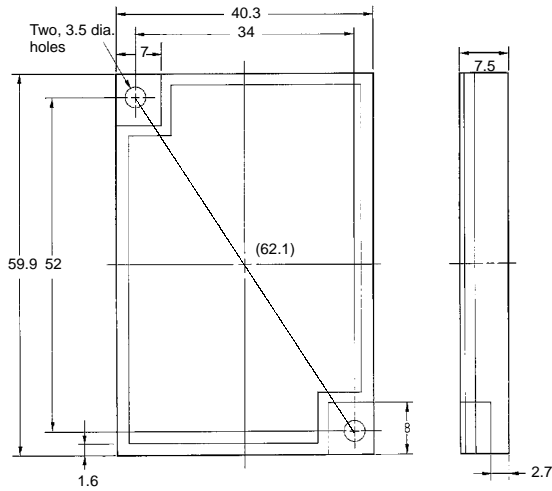
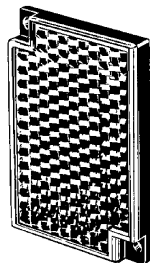

■ Accessories (Order Separately)

Vertical Mounting Bracket
(for E3S-A) E39-L59

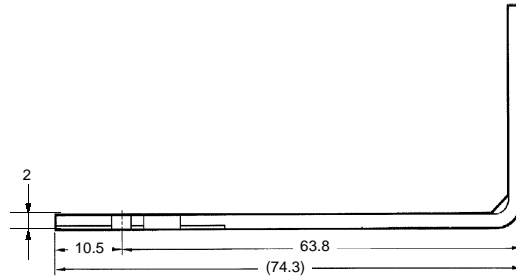
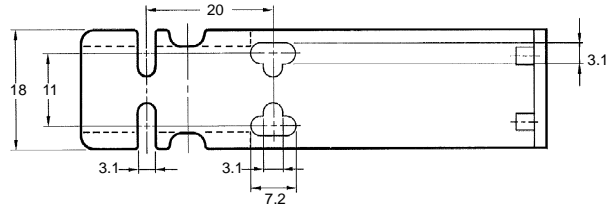
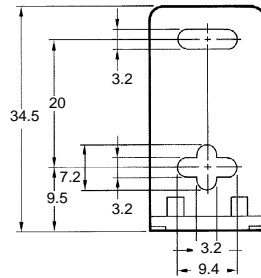
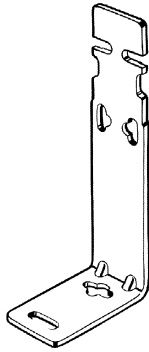

Mounting Example of E3S-A on
E39-L59

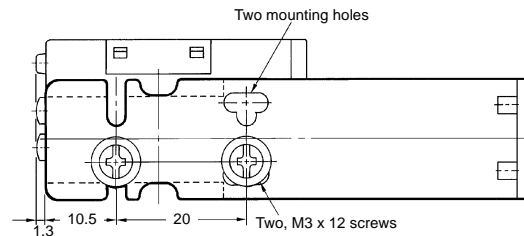
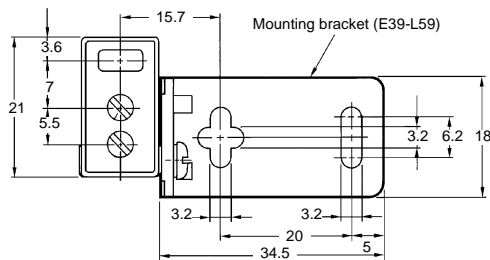
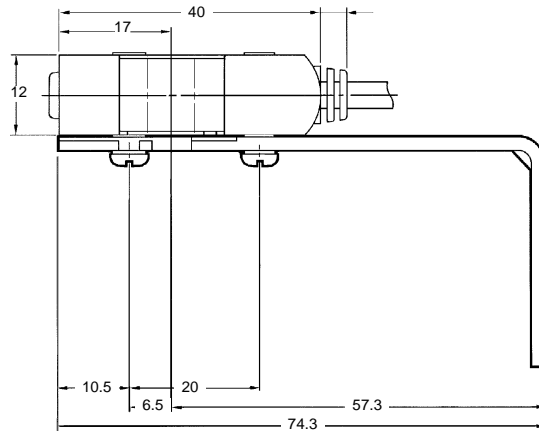

Mounting Example of E3S-A on E39-L81

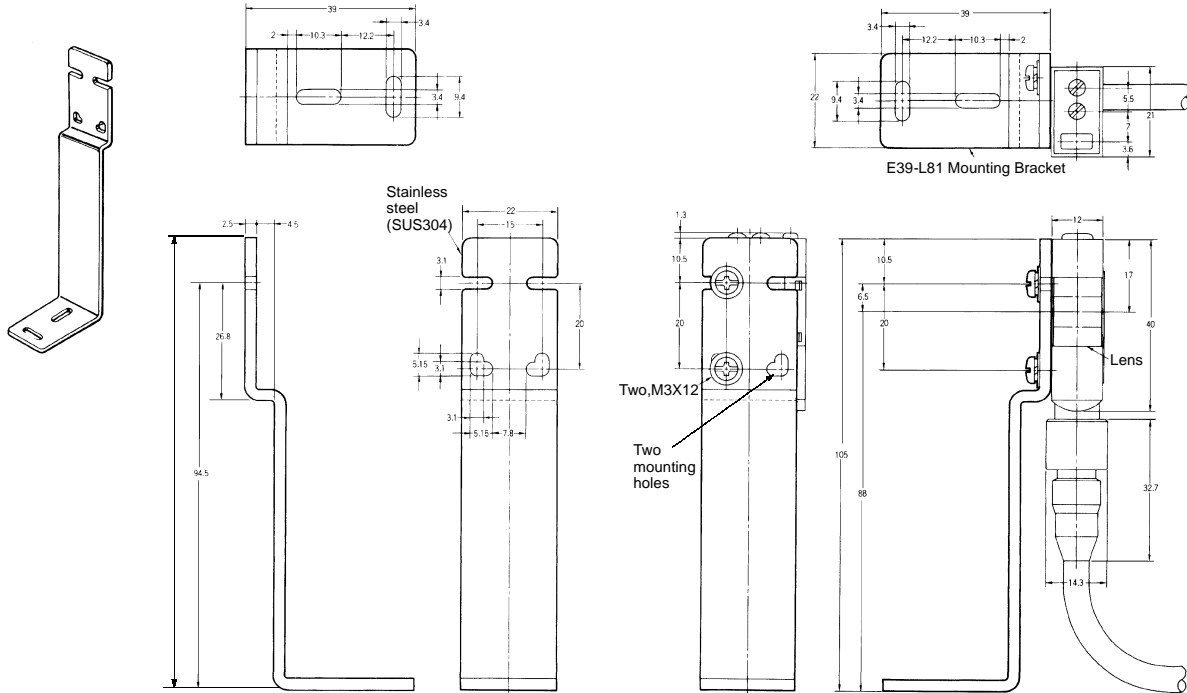

Slit (for E3S-A) E39-S46

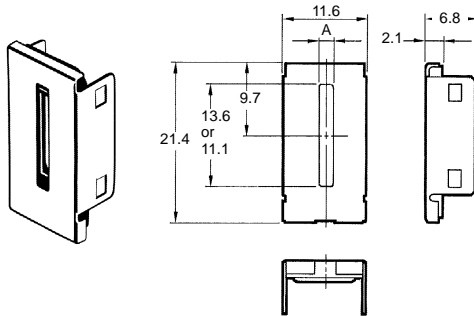

Note: The width of A is 0.5 mm, 1 mm, or 2 mm depending on the model.

Slit (for E3S-B) E39-S47

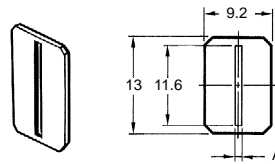

Note: 1. The width of A is 0.5 mm, 1 mm, or 2 mm depending on the model.
2. The Slit has an adhesive back.

Slit (for E3S-B) E39-S48

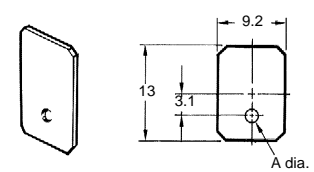

Note: 1. The width of A is 0.5 mm, 1 mm, or 2 mm depending on the model.
2. The Slit has an adhesive back.

Slit (for E3S-B) E39-S53

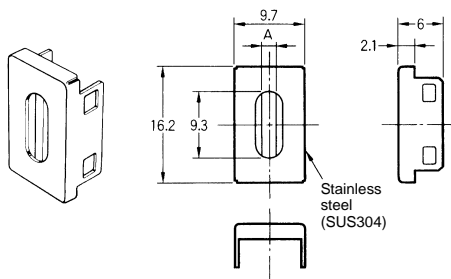

Note: The width of A is 0.5 mm, 1 mm, or 2 mm depending on the model.

Slit (for E3S-B) E39-S54

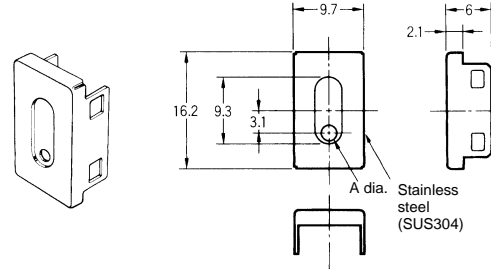

Note: The width of A is 0.5 mm, 1 mm, or 2 mm depending on the model.

**Filters for Mutual Interference Prevention
(for E3S-A) E39-E6**

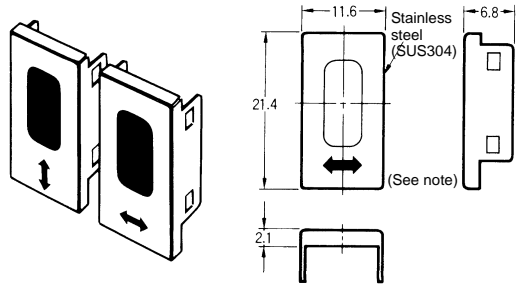

**Filters for Mutual Interference Prevention
(for E3S-B) E39-E8**

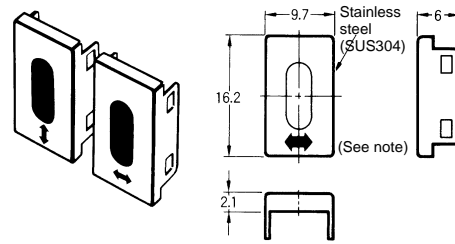

Note: Two vertical filters and two horizontal filters are sold together.

Mini-reflector E39-R4

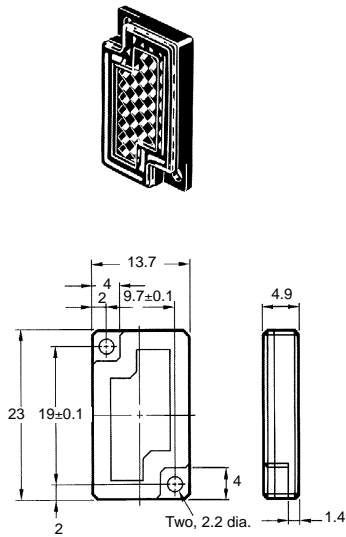

**Optical Axis Confirmation Reflector
(for E3S-A) E39-R5**

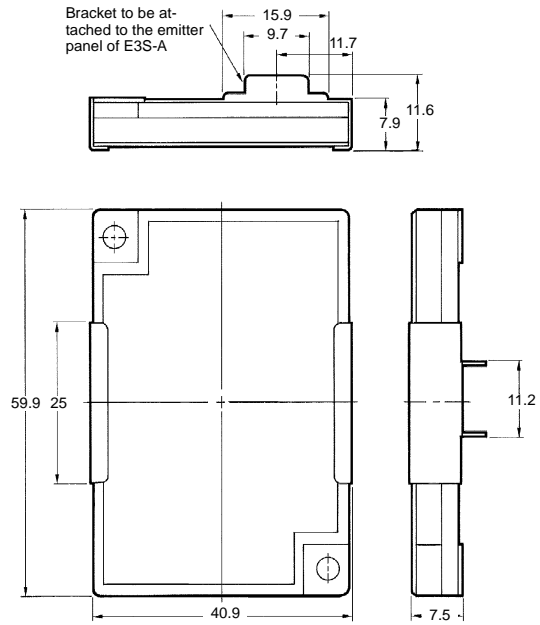

Small Reflector E39-R3

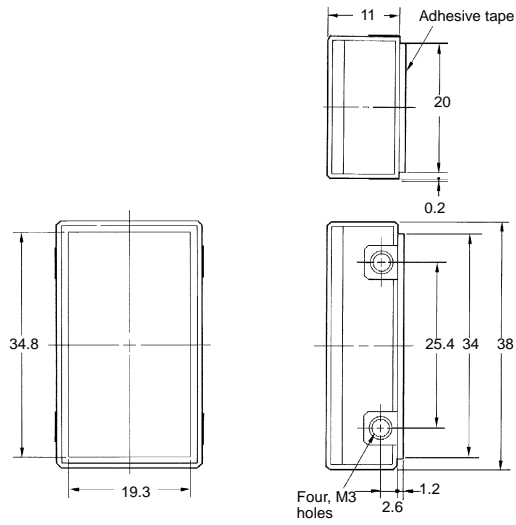
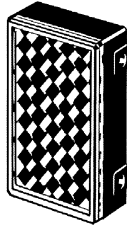

With Enclosed Mounting Bracket

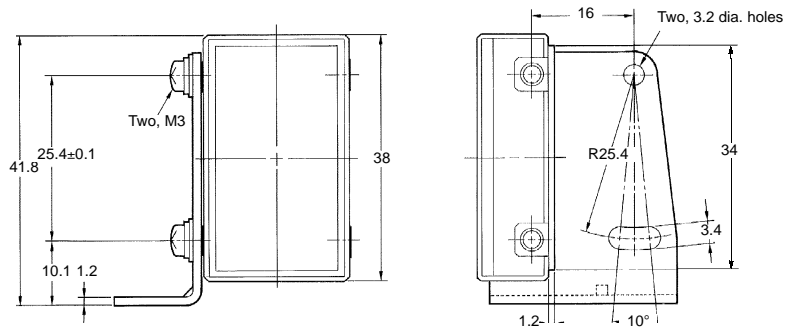
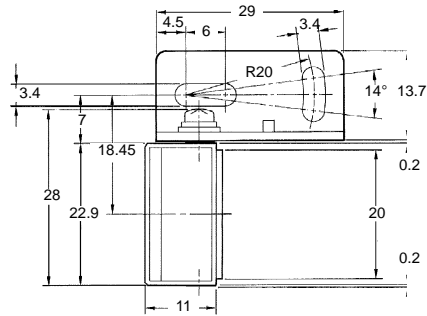

Reflecting Tape E39-RSA

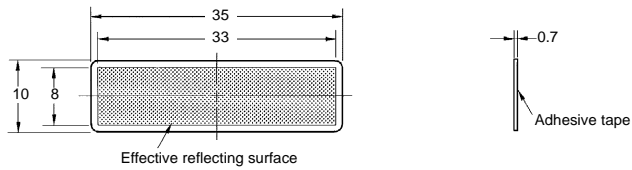

Reflecting Tape E39-RSB

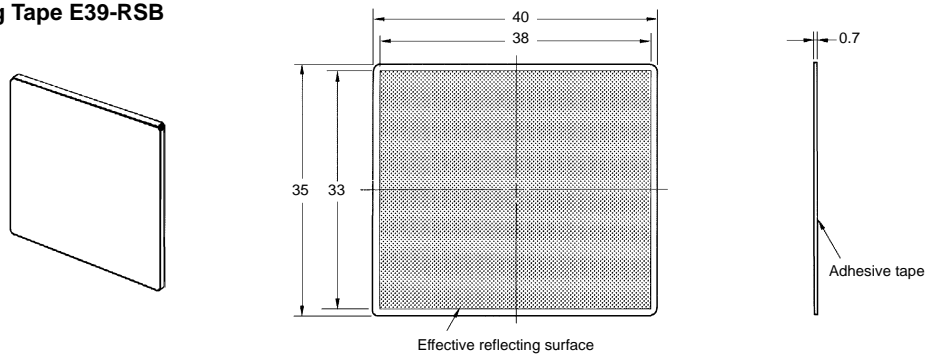

Item	E39-R3	E39-RSA	E39-RSB	E39-R4
Directional angle	30° min.			
Ambient temperature	Operating: -25°C to 55°C Storage: -40°C to 70°C			
Ambient humidity	Operating: 35% to 85% Storage: 35% to 95%			
Enclosure rating	IP67			

The above reflector tapes are polarizing.

Installation

■ Connections (Without Self-diagnostic Function)

Load (Relay)

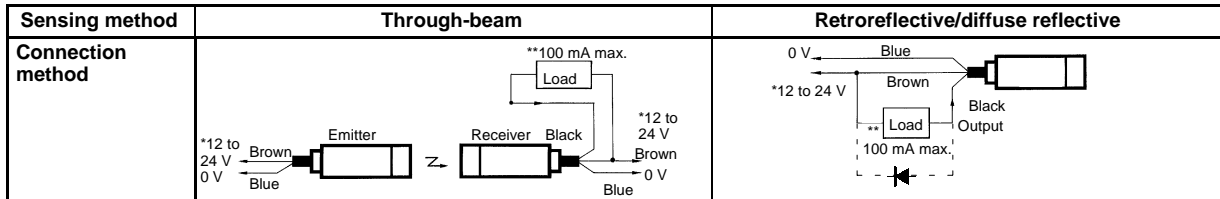

*10 to 30 V for the E3S-A

**If the load is a relay, insert a surge absorbing diode between the coils of the relay.

***The connection examples are for sensors with the NPN output.

With Sensor Controller (S3D2)

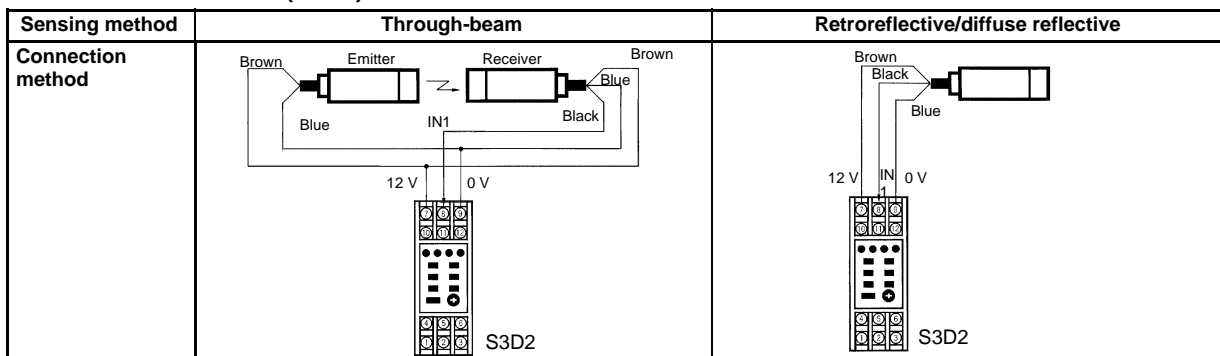

■ Plug (for E3S-A with Connector)

Internal Connection

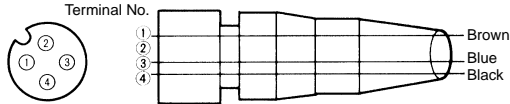

Item	Color of cord	Coonection pin No.	Application
For DC	Brown	1	Power supply (+V)
	Black	4	Output
	Blue	3	Power supply (0 V)

Note: Pin No. 2 and 4 are connected internally.

External Connections

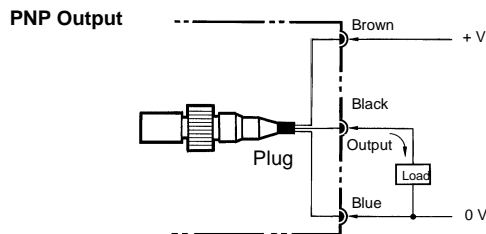
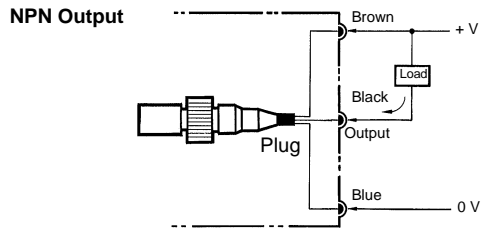

Tightening the Plug

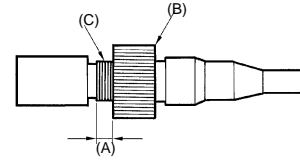

Turn part B by hand (do not use a pliers or the plug will be damaged) and tighten it with part C so that length A is nearly zero. Part B must be tightened properly with part C, or otherwise part B could be loosen by vibration and the sensor will not maintain the specified enclosure ratings.

Note: Use the spacer (sold together) to mount the photoelectric sensor with or without the enclosed mounting bracket (refer to *Dimensions*).

Precautions

■ E3S-A/B

The supplied voltage must be within the rated voltage range. Unregulated full- or half-wave rectifiers must not be used as power supplies.

If the input/output lines of the photoelectric sensor are placed in the same conduit or duct as power lines or high-voltage lines, the photoelectric sensor could be induced to malfunction, or even be damaged, by electrical noise. Either separate the wiring, or use shielded lines as input/output lines to the photoelectric sensor.

Do not use a hammer to hit the amplifier when mounting or the amplifier will loose watertightness.

Note the following when using the E39-R3, E39-RSA, or E39-RSB reflector (tape):

1. Before applying adhesive tape to the reflector, make sure that the reflector is free from oil or dust, or otherwise the adhesive tape will not stick to the reflector properly.
2. Do not cut the reflector or the reflector will loose watertightness.
3. Do not press the reflector with a metal object or a nail, or otherwise the reflector will not function properly.

Position of Optical Axis of Through-beam Model

Unlike conventional through-beam models, the E3S Through-beam Photoelectric Sensor incorporates 2 lenses. But the lens actually in use is the one marked with an arrow indicating the position of the optical axis. When using a slit, attach it to the lens marked with the arrow.

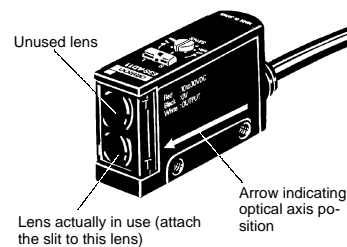

Position of Arrow Indicating Optical Axis

Model	Position of lens in use
E3S-A (vertical)	Top
E3S-A (horizontal)	Bottom
E3S-B (vertical)	
E3S-B (horizontal)	

Adjustor Cap

In order to prevent the sensitivity or OFF-delay time that has been set from changing accidentally enclosed, cover the adjustors with the adjustor cap (enclosed).

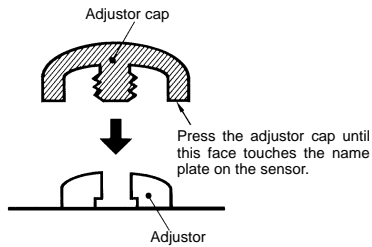

Mutual Interference Filter (E39-E6/-E8)

A set of 4 filters are sold together for two through-beam models (for 2 each of emitters and receivers).

For mounting, refer to the figure of the slit for the E3S-A Photoelectric Sensor.

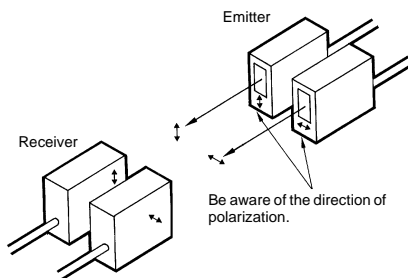

The arrow printed on the cover indicates the direction of polarization. By attaching the filters opposite to each other in polarization to the emitters and the receivers (refer to the figure) in rows, mutual interference can be prevented (in any case, the filter attached to an emitter and to the corresponding receiver must be the same in direction of polarization or the photoelectric sensor will not function).

Mounting Bracket

The direction of the optical axis coincides with the mounting direction of the E3S when the mounting screw is inserted into the lock hole of the mounting bracket. Unlike conventional photoelectric sensors, if the sensing object (or the retroreflector in the case of a through-beam sensor) is in the mounting direction of the photoelectric sensor, the object is detected with the incident light without the time-consuming adjustment of the optical axis (but if the mounting surface is not flat, the adjustment of the optical axis may still be required).

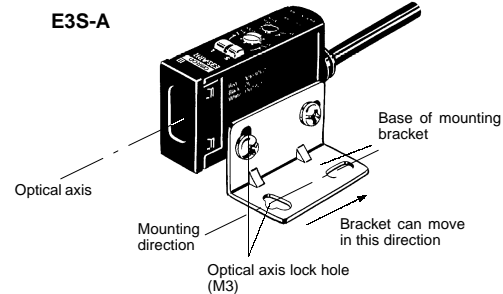

Note: The maximum tightening torque applied to the screw is 5.5 kgf S cm (0.53 N S m).

E3S-B

Align the upper side of the photoelectric sensor with that of the mounting bracket so that the photoelectric sensor will be parallel to the base of the mounting bracket.

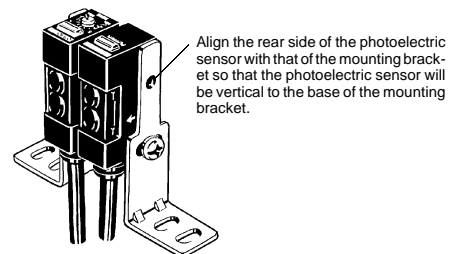
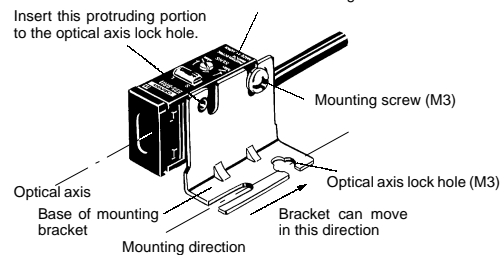

Note: The maximum tightening torque applied to the screw is 5.5 kgf S cm (0.53 N S m).

■ E3S-A

Installation of Accessories

Sensitivity Adjustor Knob (Attachment)

To temporarily use the knob to adjust the sensitivity of the photoelectric sensor, insert side A into the shaft of the sensitivity adjustor.

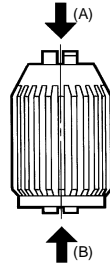

To permanently use the knob to adjust the sensitivity of the photoelectric sensor, insert side B into the shaft (the knob cannot be removed if once side B is inserted into the shaft).

Slit (E39-S46 Order Separately) for E3S-A

Use the rubber attachment with the metal cover if a slit width of 2 mm is required. Insert the 0.5- or 1-mm slit between the metal cover and rubber attachment if a slit width of 0.5 or 1 mm is desired. These slits fit into the rubber attachment.

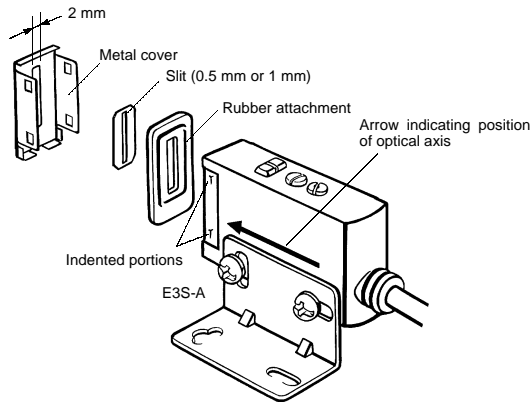

Note: Apply the slit to the lens of the photoelectric sensor marked with an arrow indicating the position of the optical axis (apply it to the bottom lens of horizontal sensors and the top lens of vertical sensors).

Optical Axis Reflector (E39-R5 Order Separately)

Use this attachment when the set distance is long and adjustment is mechanically difficult with a sensing object.

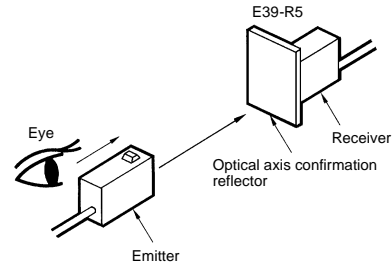

Attach the reflector to the receiver (refer to the figure).

Look at the reflector from right behind the emitter. The reflector should be bright with red light when the optical beam strikes the reflector. If the emitter has a turbo function, the reflector looks brighter with the function switched on.

When the reflector is removed, the light beam strikes the receiver.

■ E3S-B

Mounting Methods

The E3S-B Miniature Photoelectric Sensor is mounted and secured with a single mounting screw and the protruding portion on the sensor.

1. For direct mounting

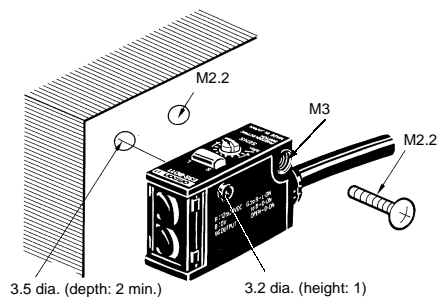
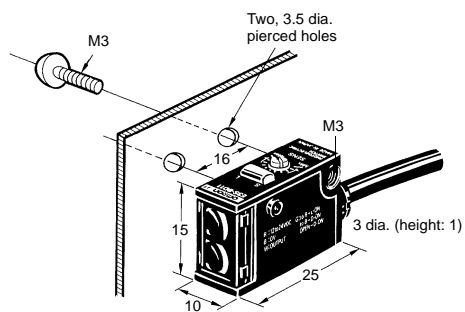

2. With mounting bracket (attachment)

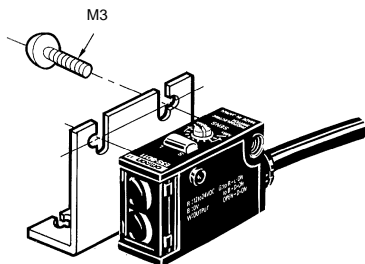

3. For close mounting of photoelectric sensors

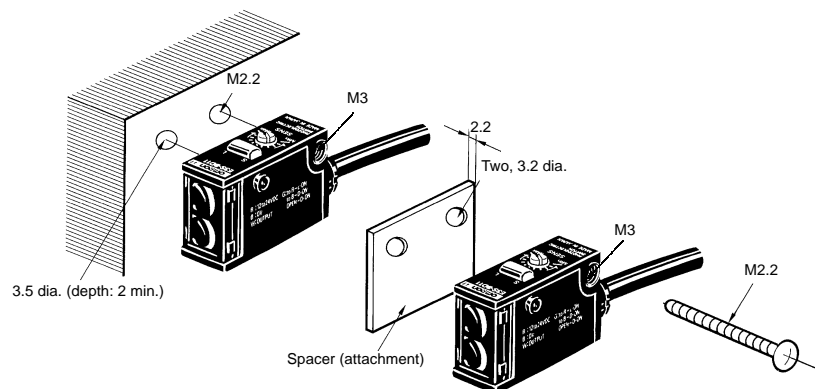

Installation of Accessories

Slit (E39-S47, -S48 Attachment)

Peel off the protective sheet and attach the slit seal to the emitter panel of the photoelectric sensor. Do not touch the panel or the lens by hand in order to avoid oil sticking on the panel surface. Remove any oil on the panel or the slit will not stick properly.

Note: Like the E3S-A Photoelectric Sensor, apply the slit to the lens of the E3S-B Photoelectric Sensor marked with an arrow indicating the position of the optical axis (apply it to the bottom side lens of both the horizontal and the vertical models).

ALL DIMENSIONS SHOWN ARE IN MILLIMETERS.

To convert millimeters into inches, multiply by 0.03937. To convert grams into ounces, multiply by 0.03527.

Cat. No. E220-E1-3 **In the interest of product improvement, specifications are subject to change without notice.**

OMRON Corporation

Industrial Sensors Division
Sensing Devices and Components Division H.Q.
28th Fl., Crystal Tower Bldg.,
1-2-27, Shiromi, Chuo-ku,
Osaka 540-6028 Japan
Phone: (81)6-949-6012 Fax: (81)6-949-6021

Printed in Japan
1198-1M (0991) a