

Mounting Brackets

Model	Fitting materials	Count	Accessories			Applicable sensor (mounting pitch on sensor side)	Page Dimensions
			Description	Material	Count		
E39-L2	Iron, zinc plating	1	Hexagonal bolts M4 × 12 (with spring and plain washers)	Iron, zinc plating	2	E3S-RS30E4□ (25.4) E3S-R1E4□ (25.4)	5
E39-L4	Iron, zinc plating	1	Slotted/Phillips screws M3 × 12 (with spring and plain washers)	Iron, zinc plating	2	E32-T16 (20)	
E39-L5	Iron, zinc plating	1	Hexagonal bolts M4 × 20 (with spring and plain washers) Nuts M4	Iron, zinc plating Iron, zinc plating	2 2	E3L-DS50E4	
E39-L6	Iron, zinc plating	1	Hexagonal bolts M4 × 12 (with spring and plain washers)	Iron, zinc plating	2	E3L-2RC4 (25.4) E3S-RS30E4□ (25.4) E3S-R1E4□ (25.4)	
E39-L31	Iron, zinc plating	1	Slotted/Phillips screws, M3 × 12 (with spring washers)	Iron, zinc plating	2	E3C-S50 (8)	
E39-L40	Iron, zinc plating	1	Phillips screws M4 × 25 (with spring and plain washers) Nuts M4	Iron, zinc plating Iron, zinc plating	2 2	E3JK	
E39-L41	Iron, zinc plating	2	Phillips screws M3 × 14 (with spring washers) Plain washer M3	Iron, zinc plating Iron, zinc plating	4 4	E3C-1 (10)	
E39-L42	Iron, black coating	2	Phillips screws M3 × 10 (with spring washers) Plain washer M3	Iron, zinc plating Iron, zinc plating	4 4	E3C-2 (20) E3C-DS10 (19) E3C-VS1G (19) E3C-VS3R (19)	
E39-L43	Stainless steel (SUS304)	1	Slotted/Phillips screws M3 × 8 (with spring and plain washers)	Stainless steel (SUS304)	2	E3Z pre-wired model (25.4)	6
E39-L44	Stainless steel (SUS304)	1	Slotted/Phillips screws M3 × 8 (with spring and plain washers)	Stainless steel (SUS304)	2	E3Z pre-wired model (25.4)	
E39-L51	Iron, zinc plating	1	Slotted/Phillips screws M4 × 30 (with spring and plain washers) Nuts M4	Iron, zinc plating Iron, nickel plating	2 2	E3JM (40)	
E39-L53	Iron, zinc plating	1	---	---	---	E3JM (40)	
E39-L54V	Stainless steel (SUS304)	1	---	---	---	E32-T54V	6
E39-L69	Stainless steel (SUS304)	1	Slotted/Phillips screws M3 × 12 (with spring and plain washers)	Stainless steel (SUS304)	2	E3S-R1□ (20) E3S-R3□ (20)	
E39-L70	Stainless steel (SUS304)	1	Slotted/Phillips screws M3 × 12 (with spring and plain washers)	Stainless steel (SUS304)	2	E3S-R6□ (20) E3S-R8□ (20)	
E39-L83	Stainless steel	1	---	---	---	E32-T24S E32-A03	
E39-L85	Stainless steel (SUS304)	1	Hexagonal bolts M4 × 12 (with spring and plain washers)	Iron, zinc plating	2	E3S-C (25.4)	
E39-L86	Stainless steel (SUS304)	1	Hexagonal bolts M4 × 12 (with spring and plain washers)	Iron, zinc plating	2	E3S-C (25.4)	
E39-L87	Stainless steel (SUS304)	1	Hexagonal bolts M4 × 12 (with spring and plain washers)	Iron, zinc plating	2	E3S-C (25.4) E3S-CR62/67 (25.4)	

Note: Applicable models that appear shaded come with the Mounting Brackets at left as accessories.

Model	Fitting materials	Count	Accessories			Applicable sensor (mounting pitch on sensor side)	Page Dimensions
			Description	Material	Count		
E39-L93FH	Stainless steel (SUS304)	1	Holder (upper)	Heat-resistant ABS resin	1	E3Z (25.4) E3S-R1□/R3□ /R6□/R8□ (20) E39-R1/E39-R3	8
			Holder (lower)	66 nylon	1		
			Pipe	Stainless steel (SUS304)	1		
E39-L93FV	Stainless steel (SUS304)	1	Bolts M4 × 12 with Hexagonal holes	Iron, nickel plating	2		
			Bolts M4 × 30 with hexagonal holes	Iron, nickel plating	1		
E39-L93H	Stainless steel (SUS304)	1	Phillips screws M3 × 12 (with spring and plain washers)	Stainless steel (SUS304)	2		
E39-L93V	Stainless steel (SUS304)	1	Spring washer M4	Iron, nickel plating	1		
			Plain washer M4	Iron, nickel plating	1		
			Nuts M4	Iron, nickel plating	3		
E39-L93XY	---	---	Holder	66 nylon	1		
			Pipe	Stainless steel (SUS304)	1		
			Bolts M5 × 16 with hexagonal holes	Stainless steel (SUS304)	2		
			Nuts M5	Stainless steel (SUS304)	2		
E39-L94	Iron, zinc plating	2	Phillips screws M3 × 10 Nuts M3	Iron, zinc plating Iron, zinc plating	4 4	E32-T16P (19)	9
E39-L96	Stainless steel (SUS304)	1	Phillips screws M3 × 6 (with spring and plain washers)	Iron, nickel plating	2	E39-R1	
E39-L97			Slotted/Phillips screws M3 × 12 (with spring and plain washers)	Stainless steel (SUS304)	2	E3S-R1□/R3□ (20)	
E39-L98	Stainless steel (SUS304)	1	Slotted/Phillips screws M3 × 12 (with spring and plain washers)	Stainless steel (SUS304)	2	E3Z pre-wired model (25.4) E3S-R6□/R8□ (20)	10
E39-L102	Stainless steel (SUS304)	1	Hexagonal bolts M4 × 12 (with spring and plain washers)	Iron, zinc plating	2	E3S-C (horizontal type) (25.4)	
E39-L103	Stainless steel (SUS304)	1	Hexagonal bolts M4 × 12 (with spring and plain washers)	Iron, zinc plating	2	E3S-C (vertical type) (25.4) E3S-CR62/67 (25.4)	
E39-L104	Stainless steel (SUS304)	1	Slotted/Phillips screws M3 × 8 (with spring and plain washers)	Stainless steel (SUS304)	2	E3Z pre-wired model (25.4) E32-R21 (for installation of E39-R3) (25.4)	11
E39-L109	Stainless steel (SUS430)	1	---	---	---	E32-S15-□ (13.2)	
E39-L114	Stainless steel (SUS430)	2	Phillips screws M5 × 10	Iron, zinc plating	4	E3MC (28)	
E39-L115	Stainless steel (SUS304)	1	Phillips screws M5 × 8	Iron, zinc plating	4	E3MC	
E39-L116			Slotted/Phillips screws M3 × 8	Iron, nickel plating	2		
E39-L117	Stainless steel (SUS304)	1	---	---	---	E3T-S (9/15)	
E39-L118	Stainless steel (SUS304)	1	---	---	---	E3T-S (9/15)	
E39-L119	Stainless steel (SUS304)	1	---	---	---	E3T-F (8)	
E39-L120	Stainless steel (SUS304)	1	---	---	---	E3T-F (8)	
E39-L127-T1	Iron, zinc plating	1	Phillips screws M2.3 × 8	Iron, zinc plating	4	E3C-S10 (7.5)	
E39-L127-T2			Spring washer M2.3	Iron, zinc plating	4		
E39-L127-T3			Phillips screws M2.3 × 8	Iron, zinc plating	4		
	Spring washer M2.3	Iron, zinc plating	4				

Note: Applicable models that appear shaded come with the Mounting Brackets at left as accessories.

Model	Fitting materials	Count	Accessories			Applicable sensor (mounting pitch on sensor side)	Page Dimensions
			Description	Material	Count		
E39-L131	Stainless steel (SUS304)	1	Slotted/Phillips screws M4 × 25	Stainless steel (SUS304)	2	E3G-R1□ (25) E3G-L7□ (25)	12
			Spring washer M4	Stainless steel (SUS304)	2		
			Plain washer M4	Stainless steel (SUS304)	2		
			Nuts M4	Stainless steel (SUS304)	2		
E39-L132	Stainless steel (SUS304)	1	Slotted/Phillips screws M4 × 25	Stainless steel (SUS304)	2	E3G-R1□ (25) E3G-L7□ (25)	
			Spring washer M4	Stainless steel (SUS304)	2		
			Plain washer M4	Stainless steel (SUS304)	2		
			Nuts M4	Stainless steel (SUS304)	2		
E39-L135	Stainless steel (SUS304)	1	Slotted/Phillips screws M4 × 35	Stainless steel (SUS304)	2	E3G-MR19 (T) E3G-ML79 (T)	
			Spring washer M4	Stainless steel (SUS304)	2		
			Plain washer M4	Stainless steel (SUS304)	2		
			Nuts M4	Stainless steel (SUS304)	2		
E39-L136	Stainless steel (SUS304)	1	Slotted/Phillips screws M4 × 35	Stainless steel (SUS304)	2	E3G-MR19 (T) E3G-ML79 (T)	
			Spring washer M4	Stainless steel (SUS304)	2		
			Plain washer M4	Stainless steel (SUS304)	2		
			Nuts M4	Stainless steel (SUS304)	2		
E39-L142	Stainless steel (SUS304)	1	Slotted/Phillips screws M3 × 8 (with spring and plain washers)	Stainless steel (SUS304)	2	E3Z pre-wired model (25.4)	
E39-L143	Stainless steel (SUS304)	1	None	---	---	E3X-DA-S/MDA E3X-NA E3C-LDA E2C-EDA	
E39-L144	Stainless steel (SUS304)	1	Slotted/Phillips screws M3 × 12 (with spring and plain washers)	Stainless steel (SUS304)	2	E3Z pre-wired model (25.4)	
E39-L148	Stainless steel (SUS304)	1	None	---	---	E3X-NA	
E39-L149	Iron, black coating	1	None	---	---	E3Z-G	
E39-L150	Stainless steel (SUS304)	1	Holder/bracket	PBT (polybutylene terephthalate)	1	E3Z (25.4) E3S-R6□/R8□ (20) E39-R3	13
			Shaft (brace)	Stainless steel (SUS304)	1		
			Bolt with hexagonal hole	Stainless steel (SUSXM7)	1		
			Nut	Stainless steel (SUS304)	1		
			Phillips screw	Stainless steel (SUSXM7)	1		
			Slotted/Phillips screws	Stainless steel (SUS304)	2		
E39-L151	Stainless steel (SUS304)	1	Holder/bracket	PBT (polybutylene terephthalate)	1	E3Z (25.4) E3S-R6□/R8□ (20) E39-R3	
			Shaft (brace)	Stainless steel (SUS304)	1		
			Bolt with hexagonal hole	Stainless steel (SUSXM7)	1		
			Nut	Stainless steel (SUS304)	1		
			Phillips screw	Stainless steel (SUSXM7)	1		
			Slotted/Phillips screws	Stainless steel (SUS304)	2		
E39-L153	Stainless steel (SUS304)	1	Slotted/Phillips screws M3 × 8 (with spring and plain washers)	Stainless steel (SUSXM7) Stainless steel (SUS304)	2	E3Z pre-wired model (25.4)	
F39-L1	Iron, zinc plating	4	Phillips screws M4 × 20	Brass, nickel-plated	8	F3W-B	
			Nuts M4	Brass, nickel-plated	8		
F39-L2	Iron, zinc plating	4	Phillips screws M4 × 25	Brass, nickel-plated	8	F3W-B	
			Phillips screws M4 × 20	Brass, nickel-plated	8		
			Nuts M4	Brass, nickel-plated	8		
			Mounting Spacer	Heat-resistant ABS resin	4		
F39-L3	Iron, zinc plating	4	---	---	---	F3W-A	
F39-L4	Iron, zinc plating	4	---	---	---	F3W-C	
F39-L5	Iron, zinc plating	4	---	---	---	F3W-C	
F39-L9	Stainless steel (SUS304)	1	Slotted/Phillips screws M3 × 25	Iron, zinc plating	2	F3UV-A	
			Plain washer M3	Iron, zinc plating	2		
F39-L10	Iron	2	Phillips screws M4 × 15	Iron	4	F3W-D	
			Nuts M4	Iron	4		
F39-L11	Iron	2	Phillips screws M4 × 15	Iron	4	F3W-D	
			Nuts M4	Iron	4		
F39-L12	Iron	2	Phillips screws M4 × 15	Iron	4	F3W-D	
			Nuts M4	Iron	4		

Note: Applicable models that appear shaded come with the Mounting Brackets at left as accessories.

Contact Mounting Plates

Model	Material	Count	Applicable type	Page
				Dimensions
E39-L60	PBT (polybutylene terephthalate)	1	E3S-R□6	15

Note: Applicable models that appear shaded come with the Mounting Brackets at left as accessories.

Slits

Model	Slit width	Installation procedure	Applicable type
E39-S39	Width 1 × 20 mm	Seal type	E3JM-10□4 (T) E3JK-5□□
E39-S60	Width 0.5, 1 × 15 mm	Seal type	E32-T16
E39-S61	Width 0.5, 1, 2, 4 × 11 mm	Plug-in type	E3S-CT□1
E39-S63	0.5-mm dia., 1 mm		E3T-ST1□
E39-S64	0.5-mm dia., 1 mm		E3T-FT1□
E39-S65A	0.5 mm dia.		E3Z-T□□
E39-S65B	1-mm dia.		
E39-S65C	2-mm dia.		
E39-S65D	Width 0.5 × 10 mm		
E39-S65E	Width 1 × 10 mm		
E39-S65F	Width 2 × 10 mm		

Note: Applicable models that appear shaded come with the Slits at left as accessories

Reflectors (Refer to Dimensions on page 16.)

Item	Name Model	Reflectors		Non-fogging reflective plate	Reflectors			Special Reflector for E3ZM-B
		E39-R1	E39-R1S	E39-R1K	E39-R2	E39-R6	E39-R10	E39-RP1
Directional angle		30° min. *1			30° min. *2	30° min.		
Ambient operating temperature range		-25 to 55°C						-40 to 60°C
Ambient storage temperature range		-40 to 70°C		-40 to 55°C		-40 to 70°C		
Ambient operating humidity range		35% to 85%					35% to 95%	35% to 85%
Ambient storage humidity range		35% to 95%						
Degree of protection		IEC IP67						
Accessories		---						

*1. 40° or higher for E3JM-R and E3JK-R.

*2. 40° or higher for E3G-R.

Item	Name Model	Small reflector				Tape reflector		
		E39-R9	E39-R3	E39-R4	E39-R37-CA	E39-RS1 E39-RS1-CA	E39-RS2 E39-RS2-CA	E39-RS3 E39-RS3-CA
Directional angle		30° min.		2° to 20° min.	30° min.			
Ambient operating temperature range		-25 to 55°C						
Ambient storage temperature range		-40 to 70°C			0 to 40°C			
Ambient operating humidity range		35% to 95%	35% to 85%					
Ambient storage humidity range		35% to 95%			35% to 85%			
Degree of protection		IEC IP67						
Accessories		---	Mounting Brackets E39-L104 (with screws)	---	Phillips screws M3 × 3, spring washers M3, nuts M3	---		

Item	Name Model	Laser Reflectors				
		Standard		Short-distance transparent object detection	Sheets	
		E39-R12	E39-R13	E39-R14	E39-RS4	E39-RS5
Ambient operating temperature range		-10 to 55°C (No icing)				
Ambient storage temperature range		-25 to 70°C (No icing)				
Ambient operating humidity range		35 to 85% (No condensation)				
Ambient storage humidity range		35 to 85% (No condensation)				

E39-L/F39-L/E39-S/E39-R

Mounting Bracket Dimensions

(Unit: mm)

Tolerance class IT16 applies to dimensions in this datasheet unless otherwise specified.

E39-L2

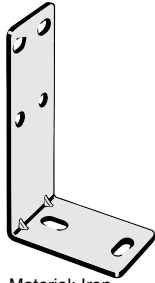

Material: Iron

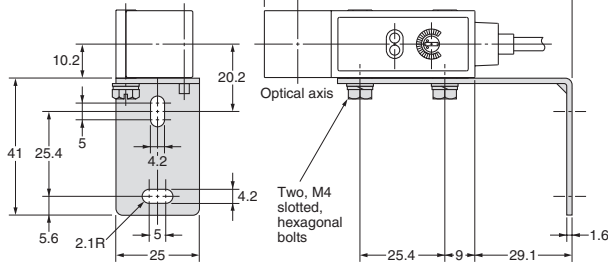

E39-L4

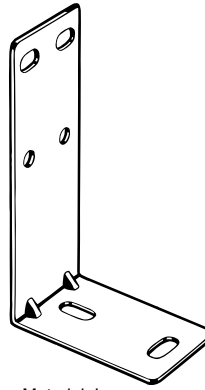

Material: Iron

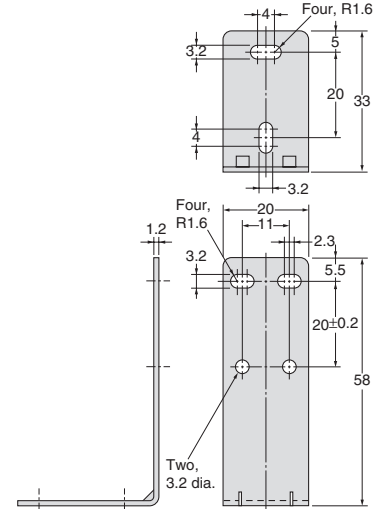

E39-L5

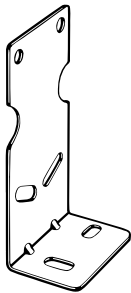

Material: Iron

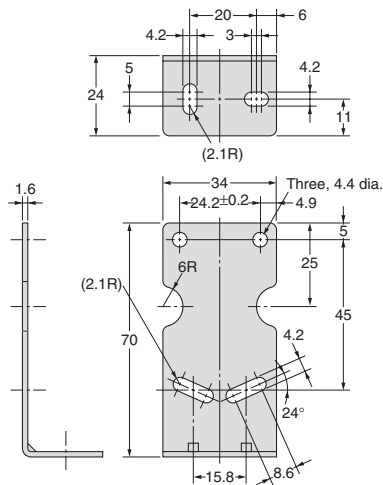

E39-L6

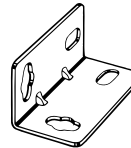

Material: Iron

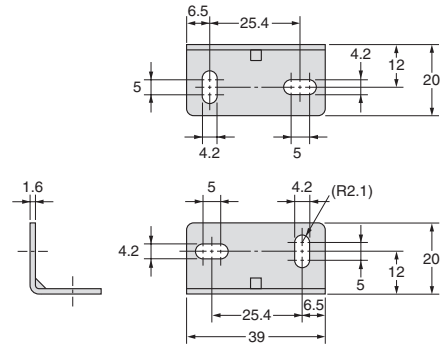

E39-L31

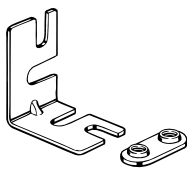

Material: Iron

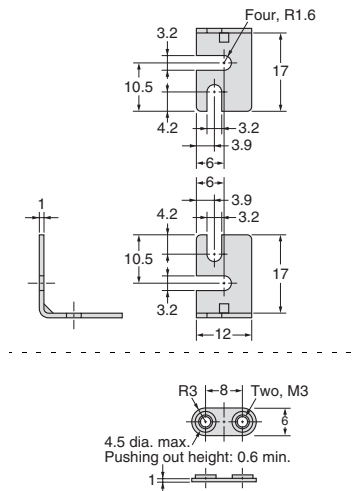

E39-L40

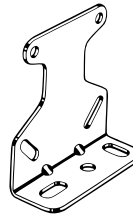

Material: Iron

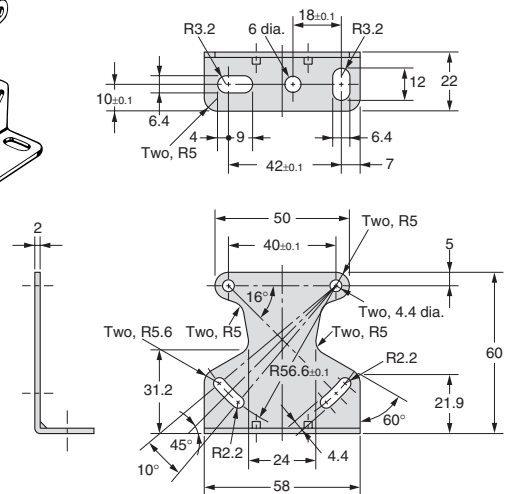

E39-L41

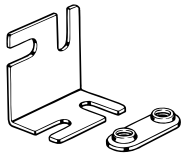

Material: Iron

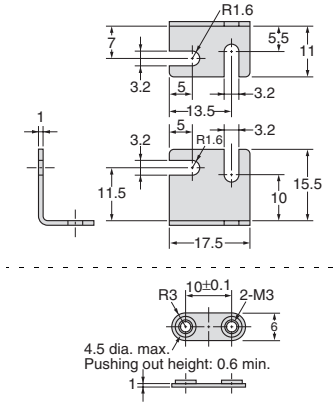

E39-L42

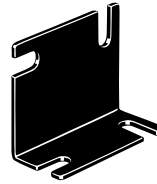

Material: Iron

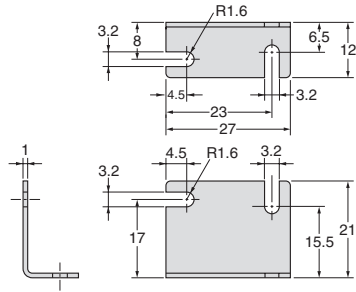

E39-L43

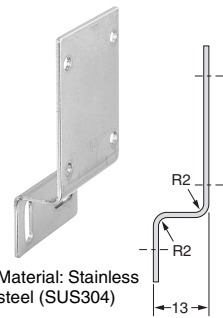

Material: Stainless steel (SUS304)

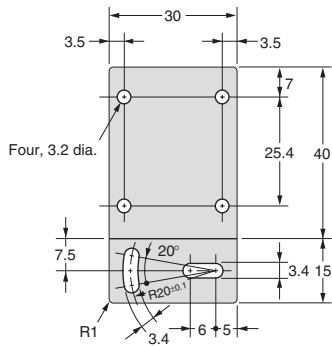

E39-L44



Material: Stainless steel (SUS304)

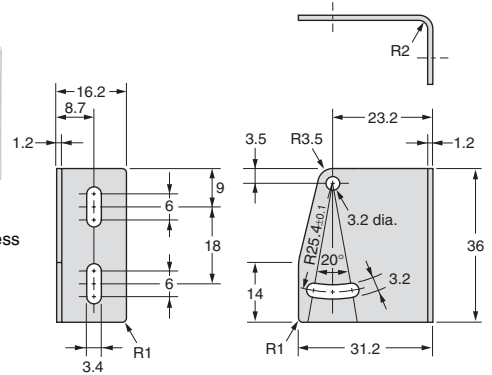

E39-L51



Material: Iron

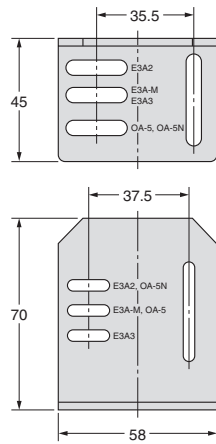

E39-L53

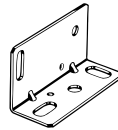

Material: Iron

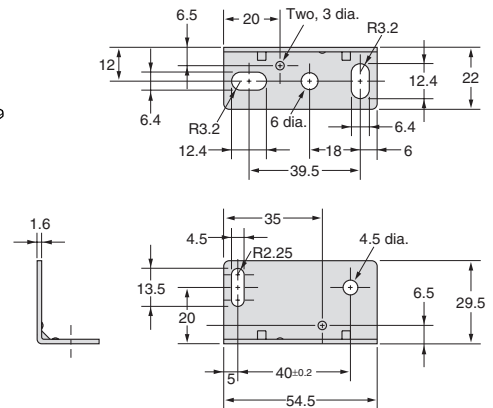

E39-L54V

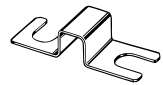

Material: Stainless steel (SUS304)

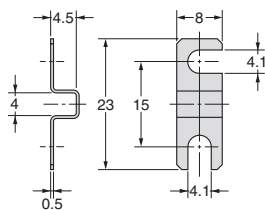

E39-L69

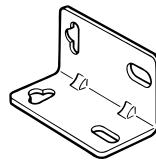

Material: Stainless steel (SUS304)

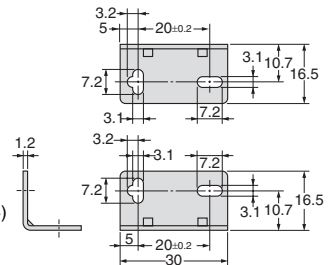

E39-L70

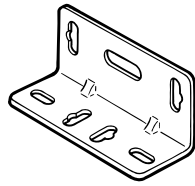

Material: Stainless steel (SUS304)

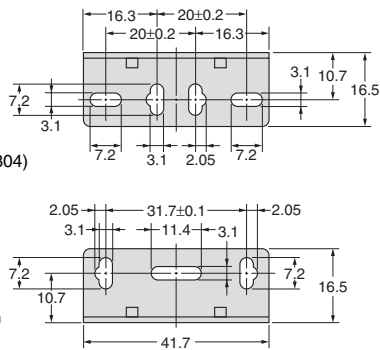

E39-L83

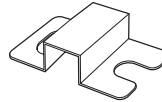

Material: Stainless steel

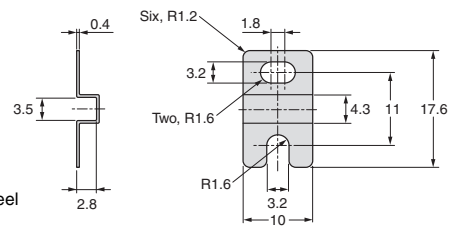

E39-L85

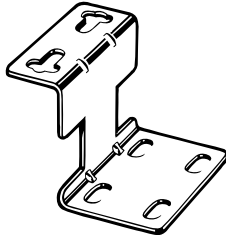

Material: Stainless steel (SUS304)

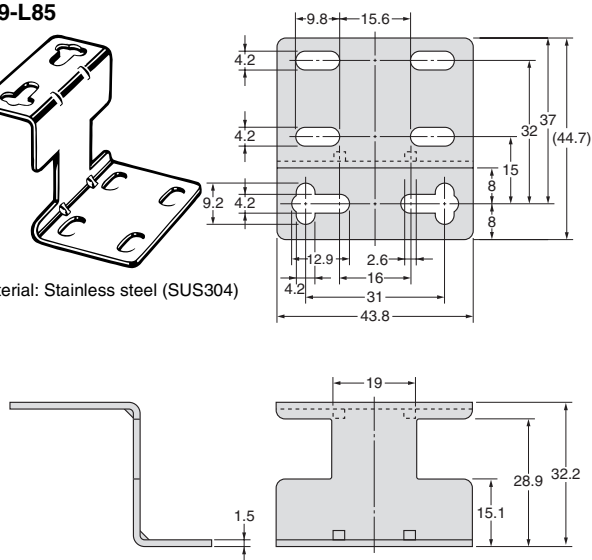

E39-L86

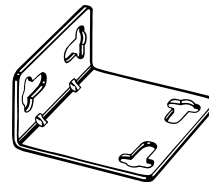

Material: Stainless steel (SUS304)

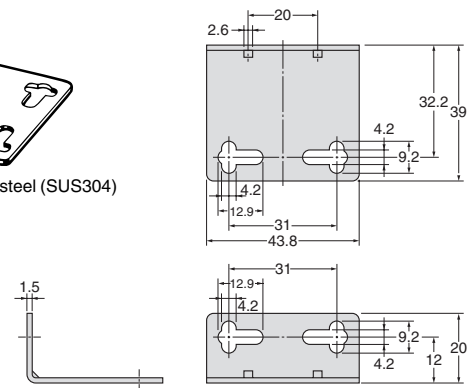

E39-L87

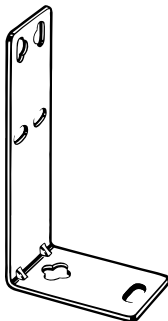

Material: Stainless steel (SUS304)

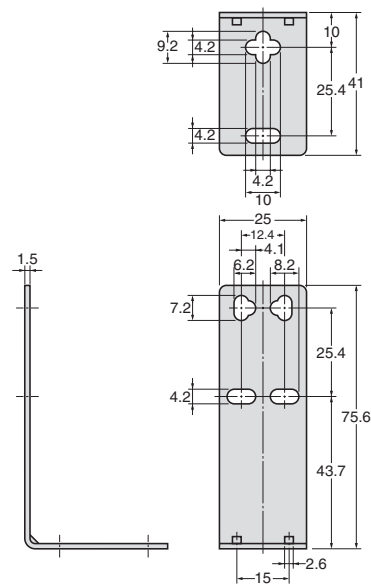

E39-L93FH

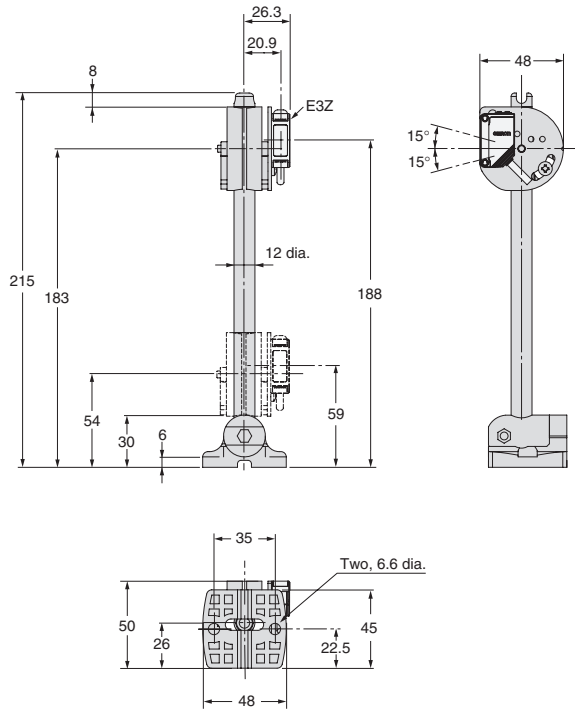

E39-L93FV

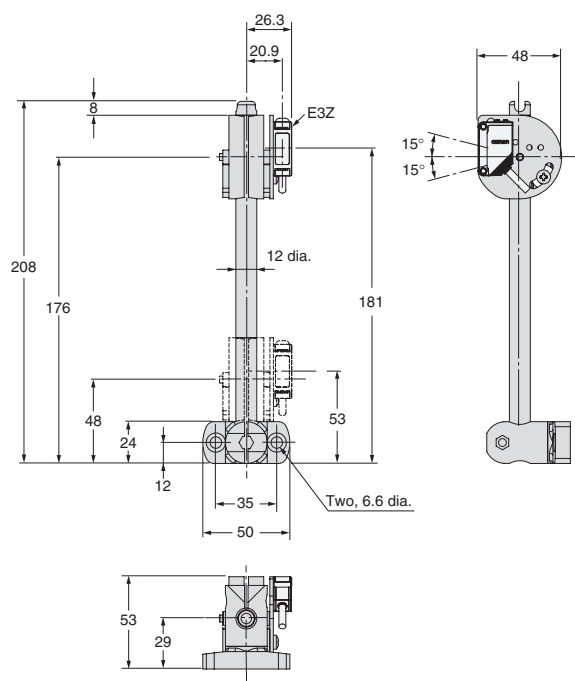

E39-L93H

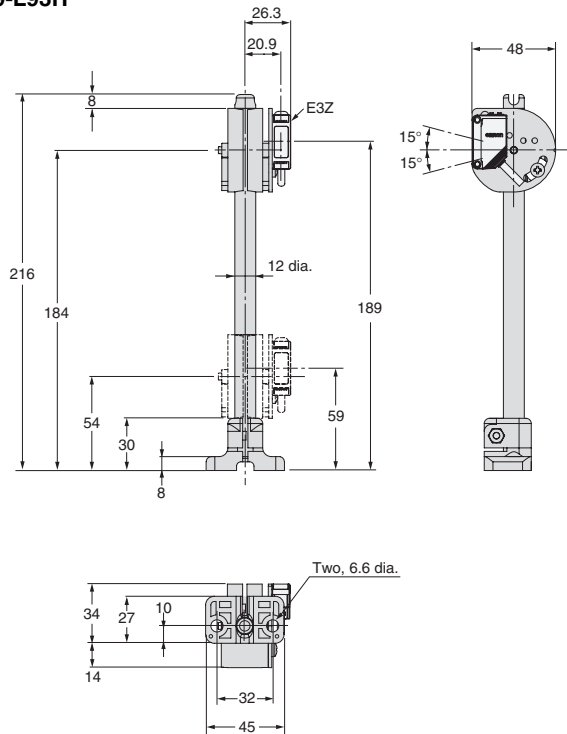

E39-L93V

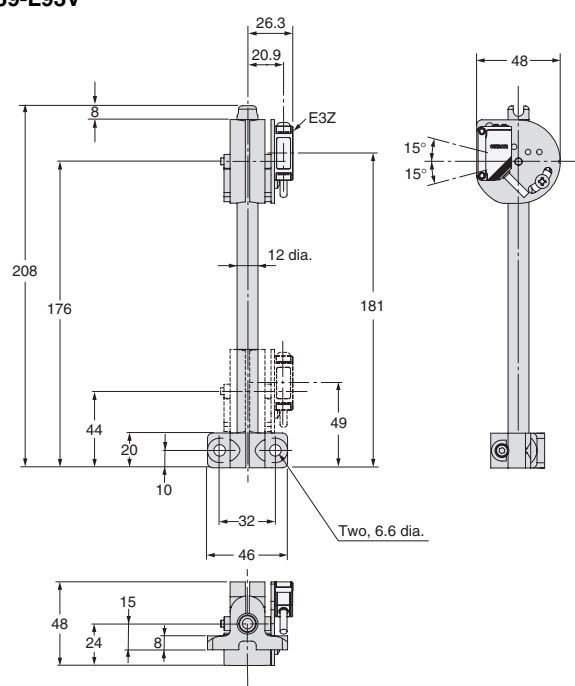

E39-L93XY

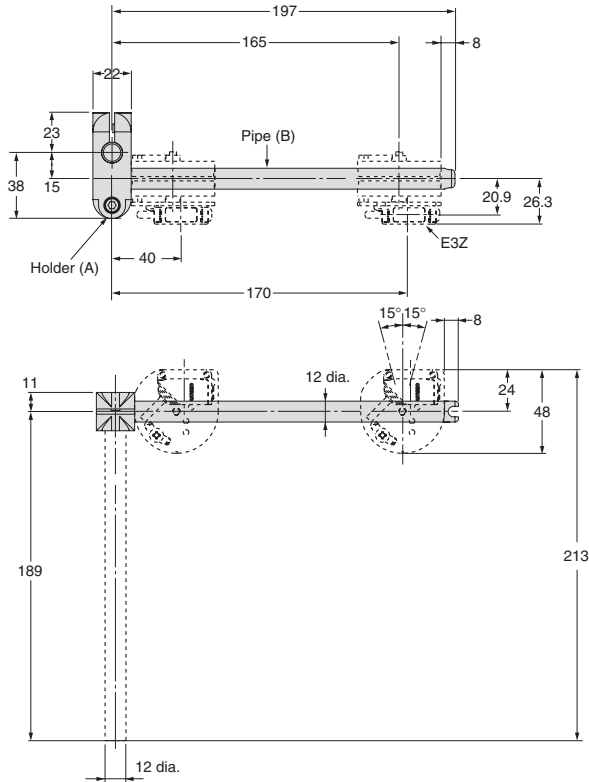

Note: The E39-L93XY consists of only the one joint holder (A) and pipe, and the two hexagonal bolts and nuts. It cannot be mounted to the Sensor alone.

E39-L94

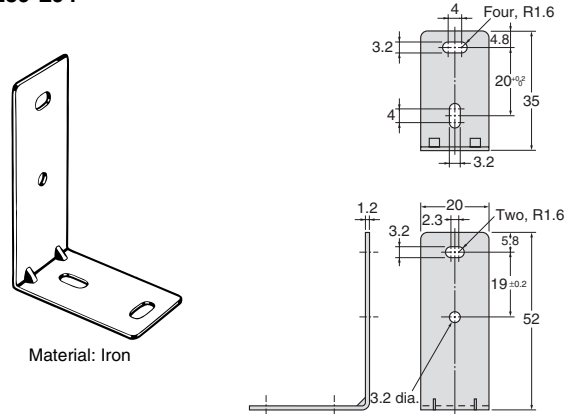

E39-L96

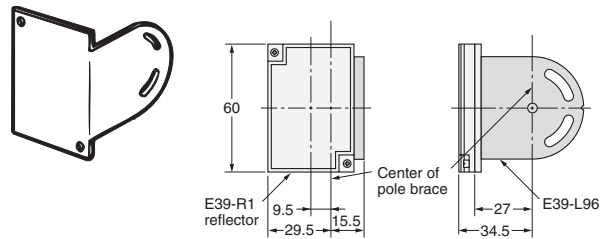

E39-L97

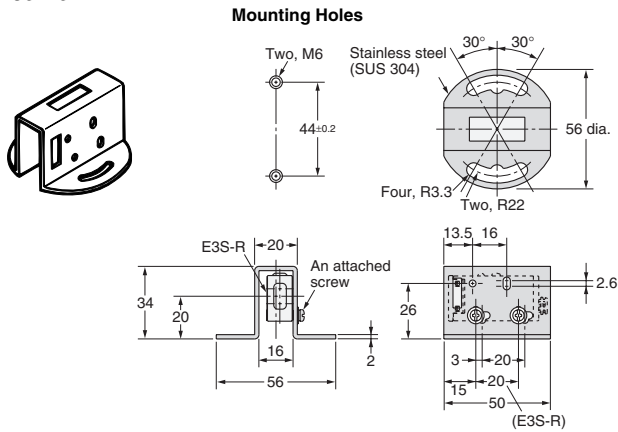

E39-L98

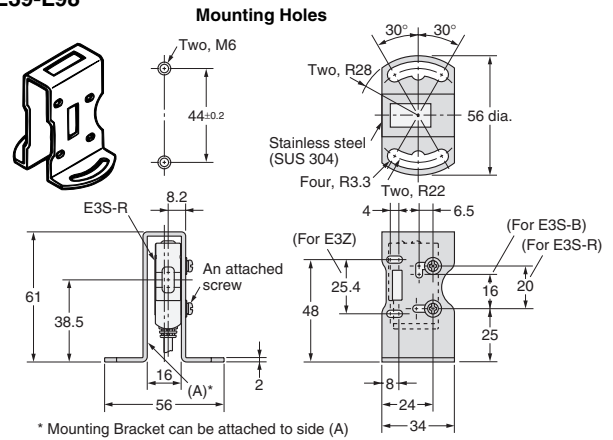

E39-L102

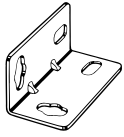

Material:
Stainless steel (SUS304)

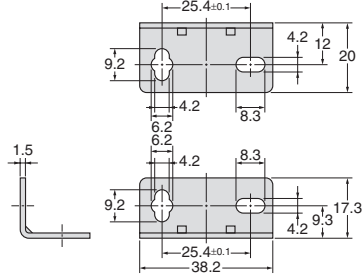

E39-L103

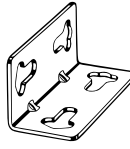

Material:
Stainless steel (SUS304)

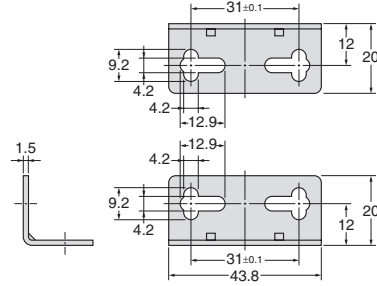

E39-L104



Material:
Stainless steel (SUS304)

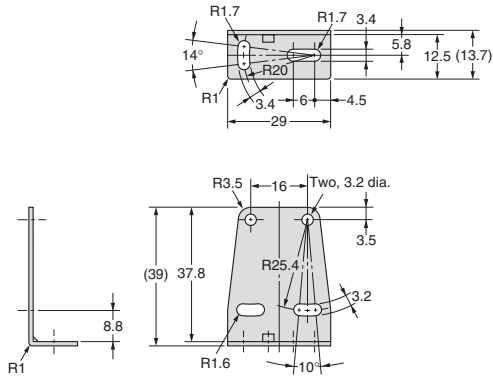

E39-L109

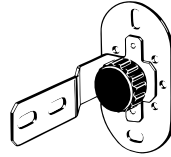

Material:
Stainless steel (SUS430)

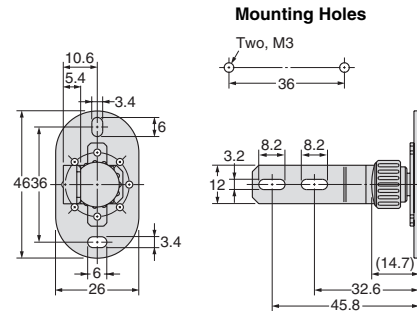

E39-L114

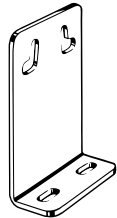

Material:
Stainless steel (SUS430)

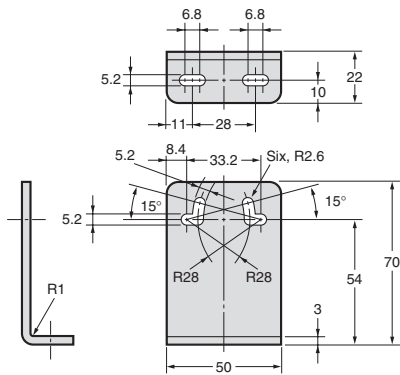

E39-L115

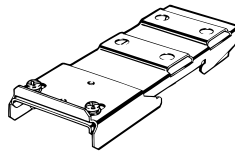

Material: Stainless steel (SUS304)

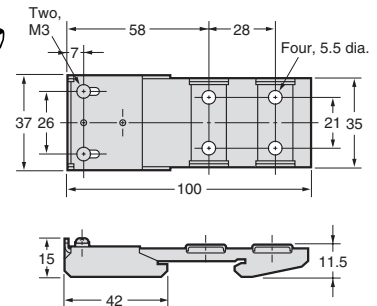

E39-L116

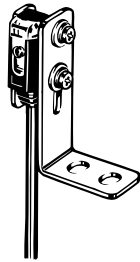

Material:
Stainless steel (SUS304)
1.2-mm-thick

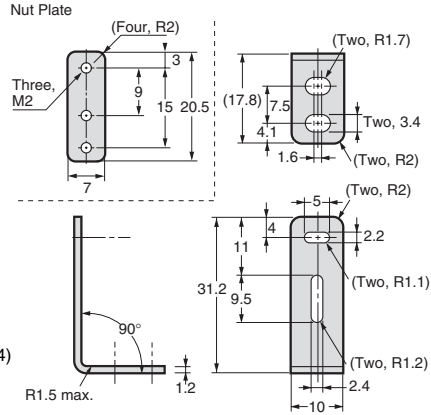

E39-L117

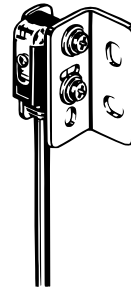

Material:
Stainless steel (SUS304)
1.2-mm-thick

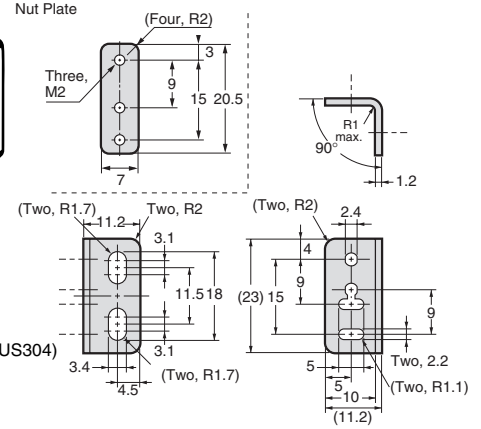

E39-L118



Material:
Stainless steel (SUS304)
1.2-mm-thick

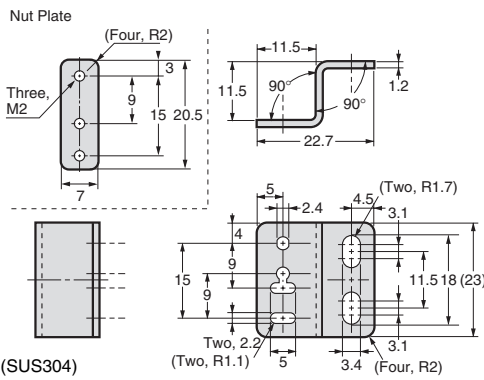

E39-L119

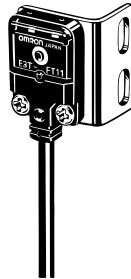

Material:
Stainless steel (SUS304)
1.2-mm-thick

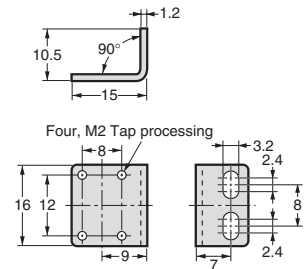

E39-L120

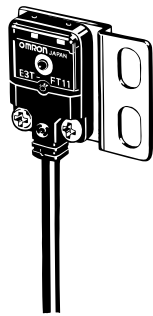

Material: Stainless steel (SUS304)
1.2-mm-thick

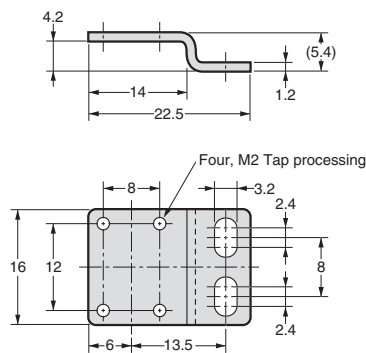

E39-L127-T1 E39-L127-T2 E39-L127-T3

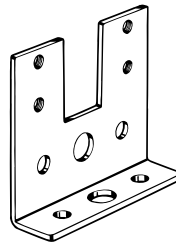

Material: Iron

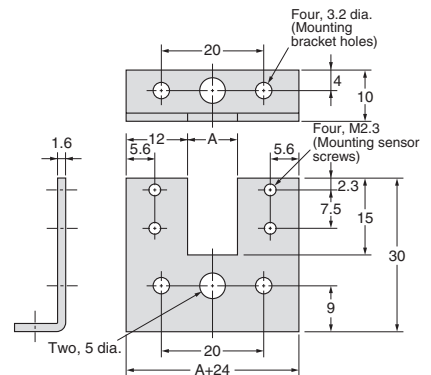

Model	Dimension A (mm)
E39-L127-T1	10
E39-L127-T2	20
E39-L127-T3	30

E39-L131

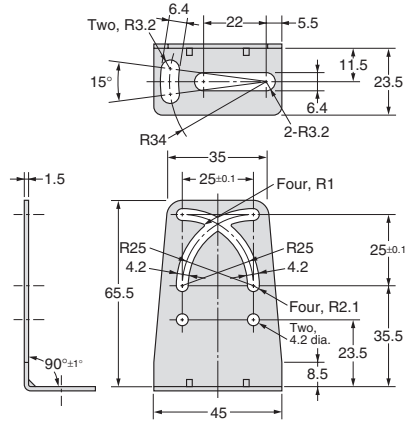
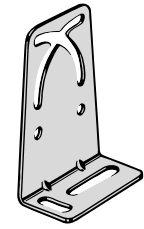

Material:
Stainless steel (SUS304)

E39-L132

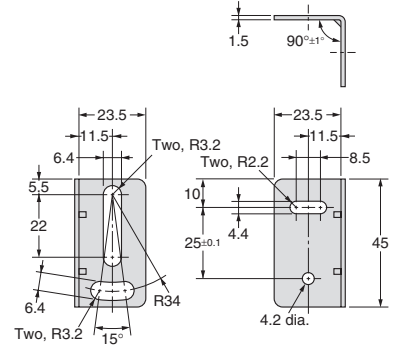
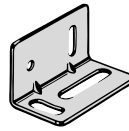

Material: Stainless steel (SUS304)

E39-L135

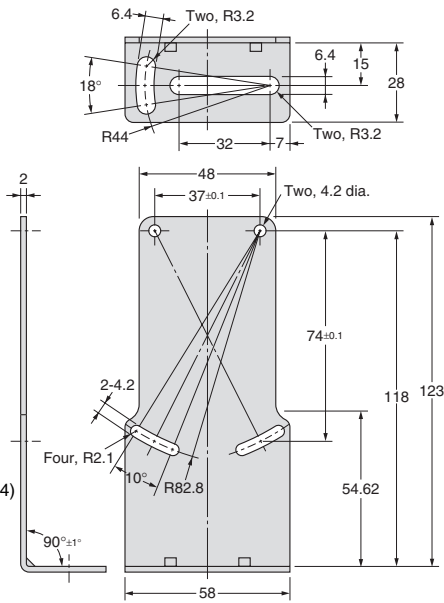
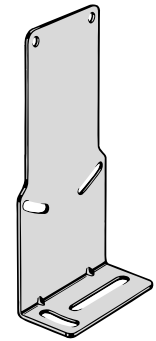

Material:
Stainless steel (SUS304)

E39-L136

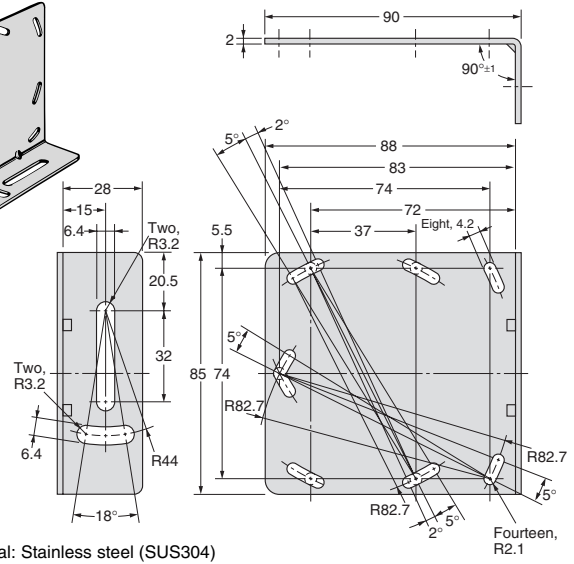
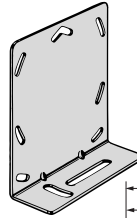

Material: Stainless steel (SUS304)

E39-L142

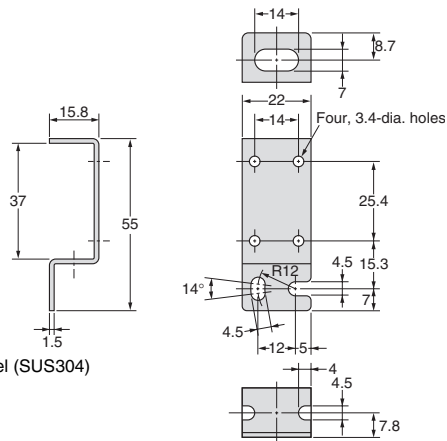

Material: Stainless steel (SUS304)

E39-L143

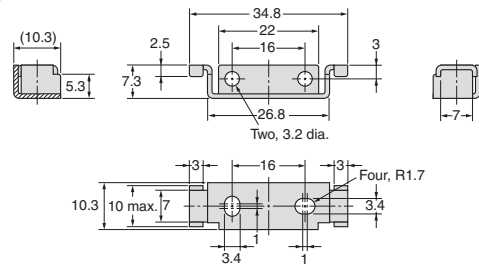
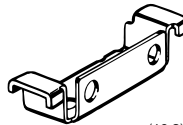

Material: Stainless steel (SUS304)

E39-L144

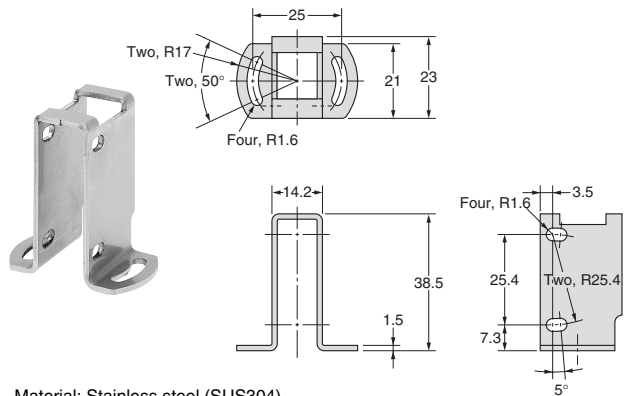

Material: Stainless steel (SUS304)

E39-L148

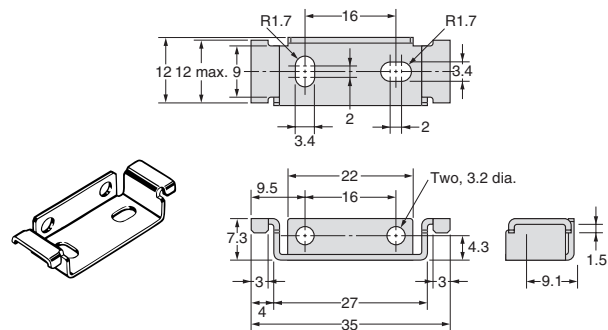

Material: Stainless steel (SUS304)

E39-L149

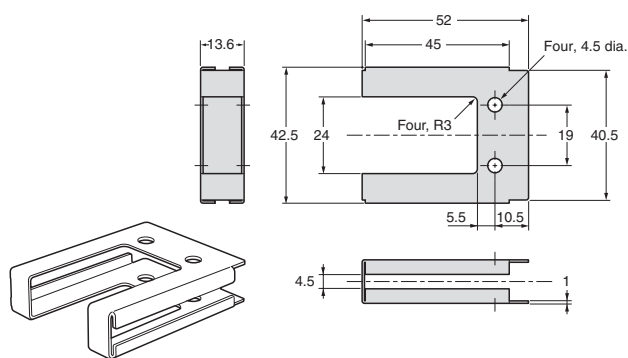

E39-L150

E39-L151

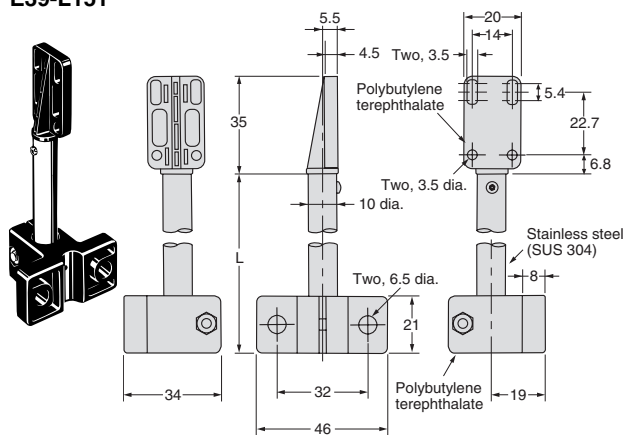

Length (mm)

Model	L
E39-L150	65
E39-L151	165

E39-L153

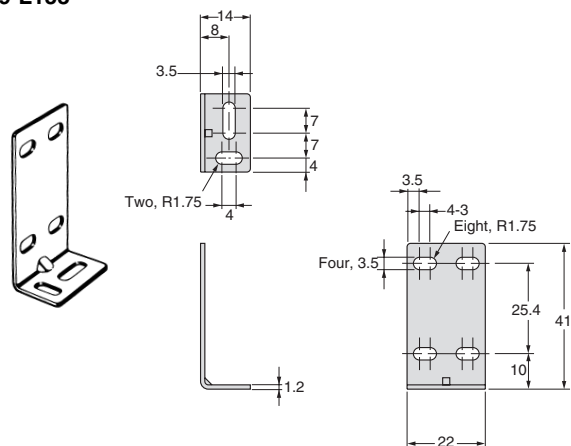

F39-L1

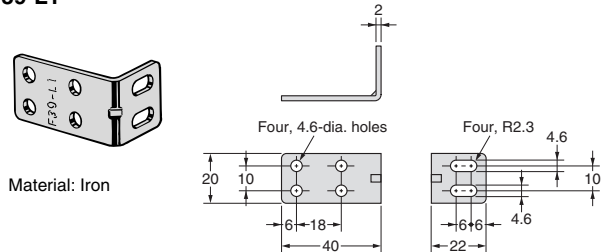

Material: Iron

F39-L2

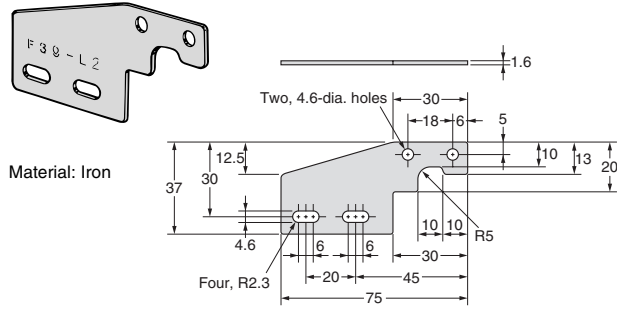

F39-L3

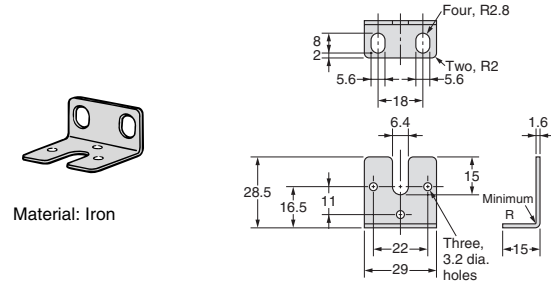

**F39-L4
C Type (Receiver, Top)**

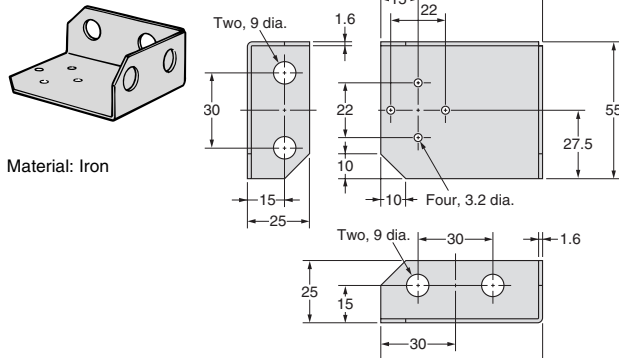

**F39-L4
D Type (Receiver, Bottom)**

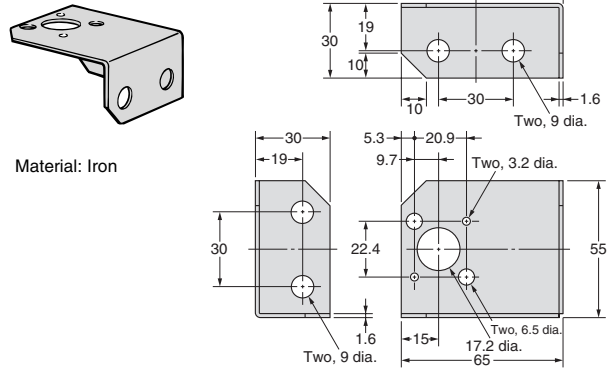

**F39-L5
A Type (Emitter, Top)**

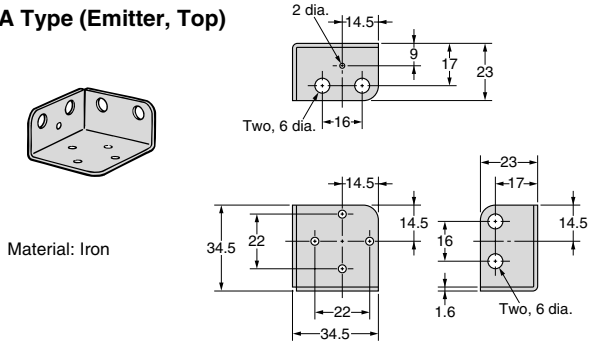

**F39-L5
B Type (Emitter, Bottom)**

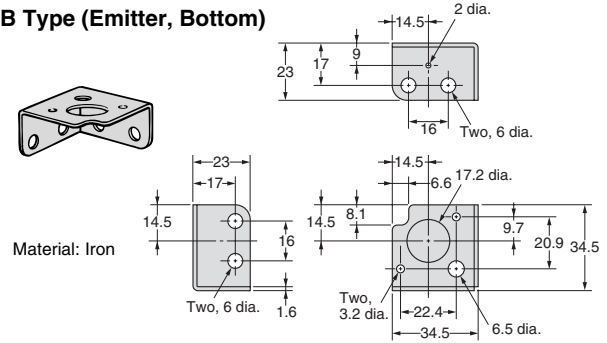

**F39-L5
C Type (Receiver, Top)**

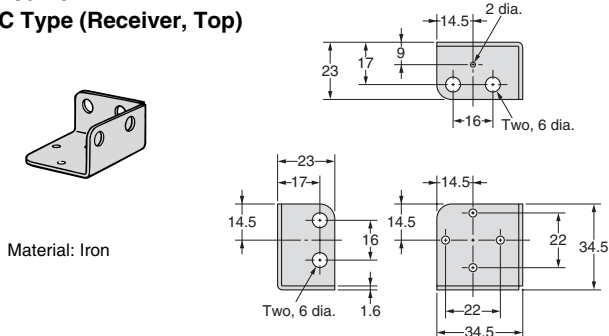

**F39-L5
D Type (Receiver, Bottom)**

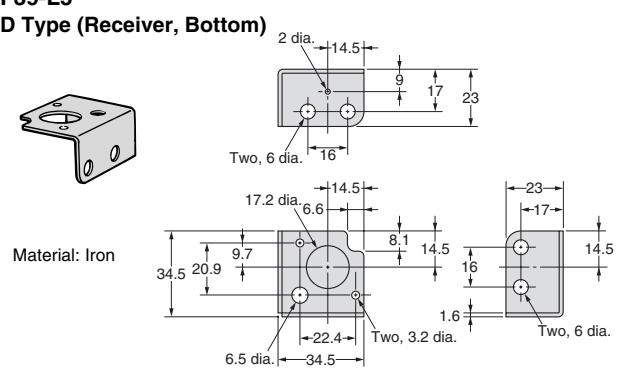

F39-L9

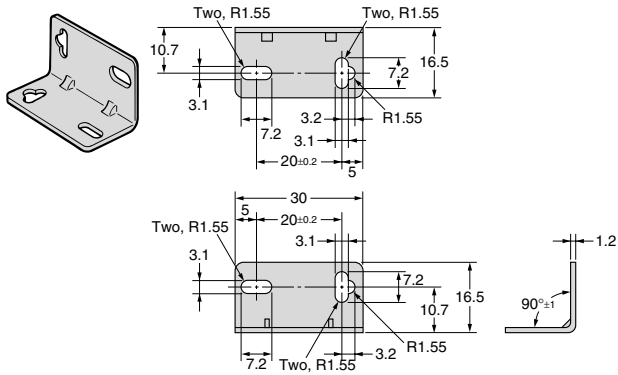

Material: Stainless steel (SUS304-CP)

F39-L10 (L-shaped)

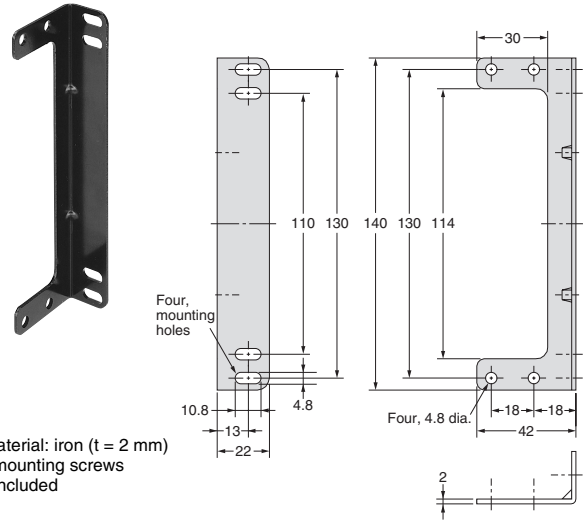

Material: iron (t = 2 mm)
* mounting screws included

F39-L11 (Flat)

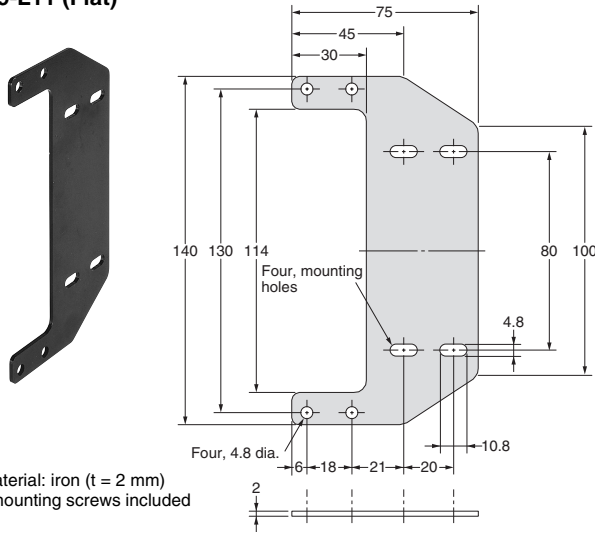

Material: iron (t = 2 mm)
* mounting screws included

F39-L12 (Receiver)



Material: iron (t = 2 mm)
* mounting screws included

Note: The Receiver sees a mirror-image of the Emitter.

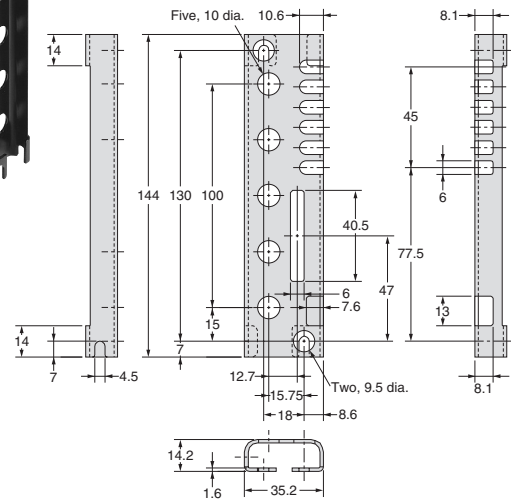

Contact Mounting Plate

(Unit: mm)
Tolerance class IT16 applies to dimensions in this datasheet unless otherwise specified.

E39-L60

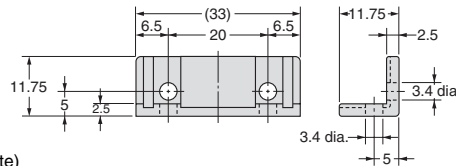
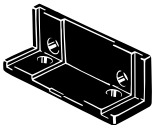

Material: PBT (polybutylene terephthalate)

E39-L/F39-L/E39-S/E39-R

Reflector dimensions

(Unit: mm)
Tolerance class IT16 applies to dimensions in this datasheet unless otherwise specified.

E39-R1
E39-R1S
E39-R1K *

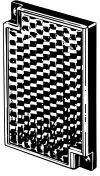

Material,
reflective surface: acrylic
Rear surface: ABS

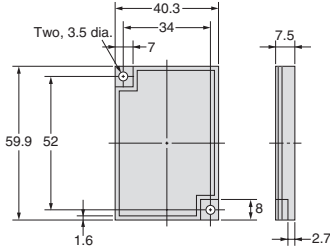

* E39-R1K only
Coating on reflective surface

E39-R2

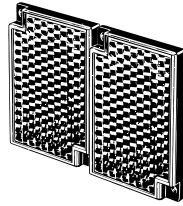

Material,
reflective surface: acrylic
Rear surface: ABS

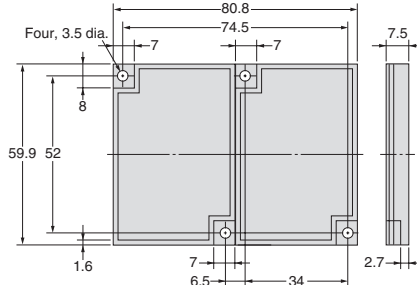

E39-R9



Material,
reflective surface: acrylic
Rear surface: ABS

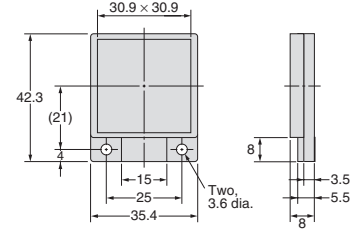

E39-R10



Material,
reflective surface: acrylic
Rear surface: ABS

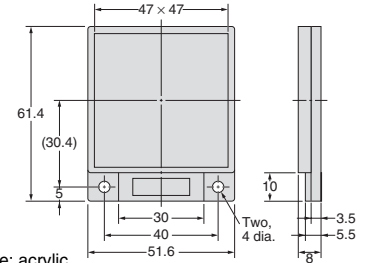

E39-R3



Material,
reflective surface: acrylic
Rear surface: ABS

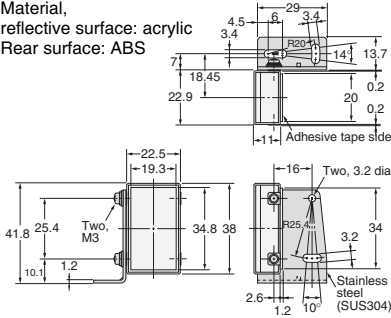

E39-R4



Material,
reflective surface: acrylic
Rear surface: ABS

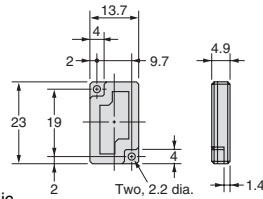

E39-R6

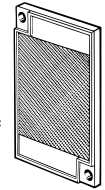

Material,
reflective surface: acrylic
Rear surface: ABS

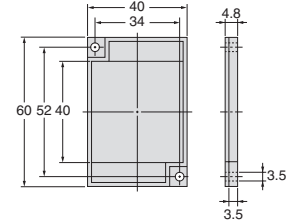

E39-R37-CA



Material:
Mounting plate: stainless steel (SUS301)
Reflective surface: acrylic

Note: The reflective plate and mounting plate (1) come as a set.

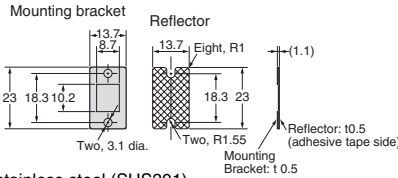

Retroreflector for E3ZM-B
E39-RP1

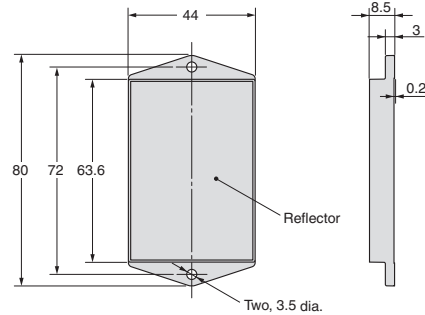

E39-RS1
E39-RS1-CA

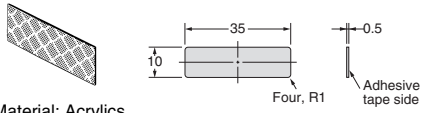

Material: Acrylics

E39-RS2
E39-RS2-CA

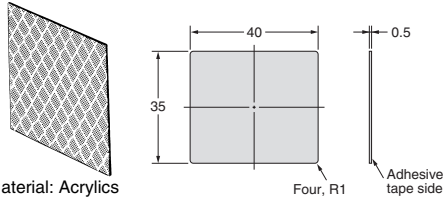

Material: Acrylics

E39-RS3
E39-RS3-CA

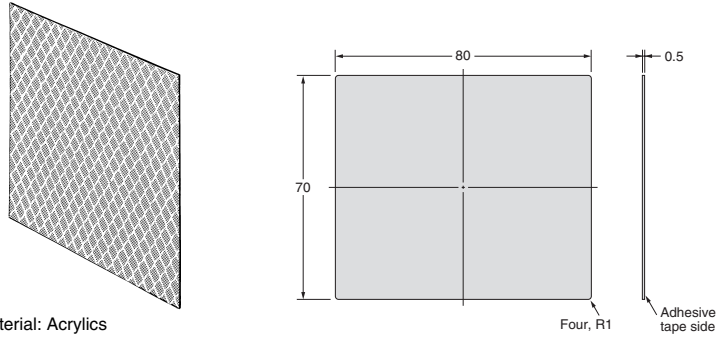

Material: Acrylics

E39-R12/R14

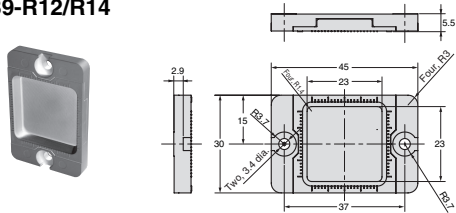

E39-R13

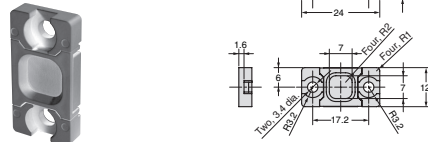

E39-RS4

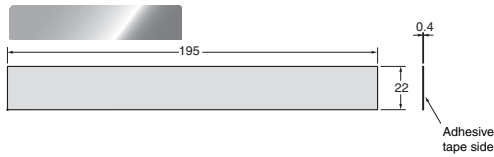

E39-RS5

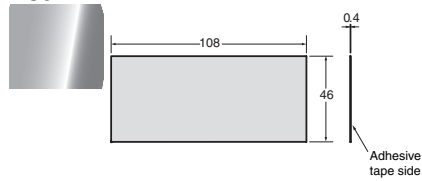

Sensitivity Adjuster

(Unit: mm)
Tolerance class IT16 applies to dimensions in this datasheet unless otherwise specified.

E39-G1



Material: Polycarbonate

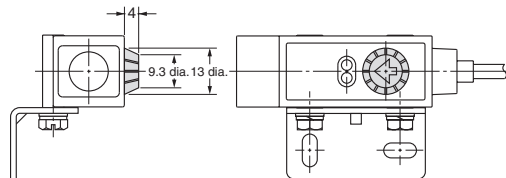

Sensitivity Adjustment Driver

(Unit: mm)
Tolerance class IT16 applies to dimensions in this datasheet unless otherwise specified.

E39-G2



Material: Polycarbonate

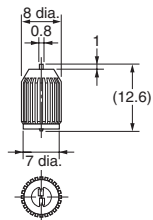

Protective Cover

(Unit: mm)
Tolerance class IT16 applies to dimensions in this datasheet unless otherwise specified.

E39-G9

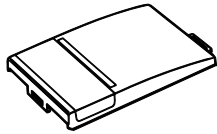

Material: Polycarbonate

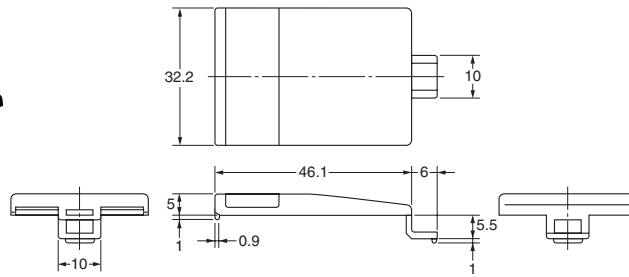

Lens Unit

(Unit: mm)
Tolerance class IT16 applies to dimensions in this datasheet unless otherwise specified.

E39-F1V

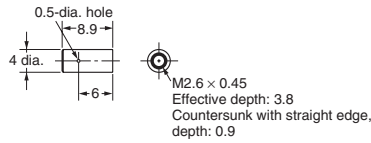

Connection Sockets

(Unit: mm)
Tolerance class IT16 applies to dimensions in this datasheet unless otherwise specified.

Front Connection Socket PF113A

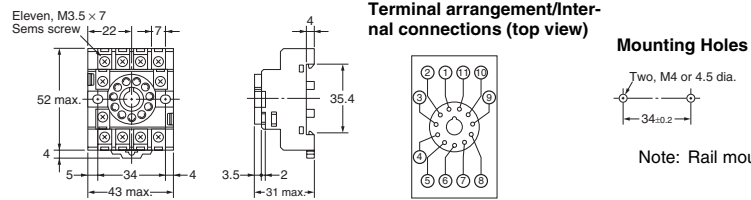
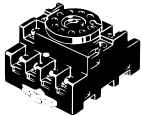

Front Connection Socket PYF08A

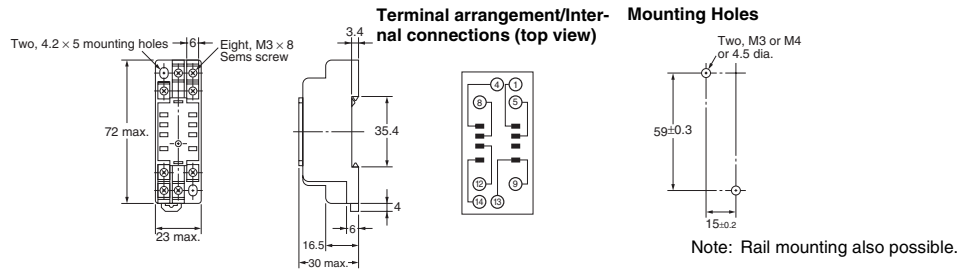
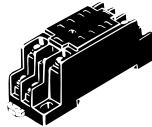

Front Connection Socket PY08

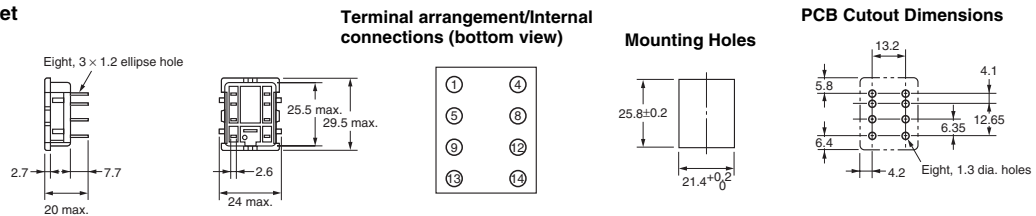
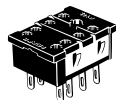

Read and Understand This Catalog

Please read and understand this catalog before purchasing the products. Please consult your OMRON representative if you have any questions or comments.

Warranty and Limitations of Liability

WARRANTY

OMRON's exclusive warranty is that the products are free from defects in materials and workmanship for a period of one year (or other period if specified) from date of sale by OMRON.

OMRON MAKES NO WARRANTY OR REPRESENTATION, EXPRESS OR IMPLIED, REGARDING NON-INFRINGEMENT, MERCHANTABILITY, OR FITNESS FOR PARTICULAR PURPOSE OF THE PRODUCTS. ANY BUYER OR USER ACKNOWLEDGES THAT THE BUYER OR USER ALONE HAS DETERMINED THAT THE PRODUCTS WILL SUITABLY MEET THE REQUIREMENTS OF THEIR INTENDED USE. OMRON DISCLAIMS ALL OTHER WARRANTIES, EXPRESS OR IMPLIED.

LIMITATIONS OF LIABILITY

OMRON SHALL NOT BE RESPONSIBLE FOR SPECIAL, INDIRECT, OR CONSEQUENTIAL DAMAGES, LOSS OF PROFITS OR COMMERCIAL LOSS IN ANY WAY CONNECTED WITH THE PRODUCTS, WHETHER SUCH CLAIM IS BASED ON CONTRACT, WARRANTY, NEGLIGENCE, OR STRICT LIABILITY.

In no event shall the responsibility of OMRON for any act exceed the individual price of the product on which liability is asserted.

IN NO EVENT SHALL OMRON BE RESPONSIBLE FOR WARRANTY, REPAIR, OR OTHER CLAIMS REGARDING THE PRODUCTS UNLESS OMRON'S ANALYSIS CONFIRMS THAT THE PRODUCTS WERE PROPERLY HANDLED, STORED, INSTALLED, AND MAINTAINED AND NOT SUBJECT TO CONTAMINATION, ABUSE, MISUSE, OR INAPPROPRIATE MODIFICATION OR REPAIR.

Application Considerations

SUITABILITY FOR USE

OMRON shall not be responsible for conformity with any standards, codes, or regulations that apply to the combination of products in the customer's application or use of the products.

At the customer's request, OMRON will provide applicable third party certification documents identifying ratings and limitations of use that apply to the products. This information by itself is not sufficient for a complete determination of the suitability of the products in combination with the end product, machine, system, or other application or use.

The following are some examples of applications for which particular attention must be given. This is not intended to be an exhaustive list of all possible uses of the products, nor is it intended to imply that the uses listed may be suitable for the products:

- Outdoor use, uses involving potential chemical contamination or electrical interference, or conditions or uses not described in this catalog.
- Nuclear energy control systems, combustion systems, railroad systems, aviation systems, medical equipment, amusement machines, vehicles, safety equipment, and installations subject to separate industry or government regulations.
- Systems, machines, and equipment that could present a risk to life or property.

Please know and observe all prohibitions of use applicable to the products.

NEVER USE THE PRODUCTS FOR AN APPLICATION INVOLVING SERIOUS RISK TO LIFE OR PROPERTY WITHOUT ENSURING THAT THE SYSTEM AS A WHOLE HAS BEEN DESIGNED TO ADDRESS THE RISKS, AND THAT THE OMRON PRODUCTS ARE PROPERLY RATED AND INSTALLED FOR THE INTENDED USE WITHIN THE OVERALL EQUIPMENT OR SYSTEM.

PROGRAMMABLE PRODUCTS

OMRON shall not be responsible for the user's programming of a programmable product, or any consequence thereof.

Disclaimers

CHANGE IN SPECIFICATIONS

Product specifications and accessories may be changed at any time based on improvements and other reasons.

It is our practice to change model numbers when published ratings or features are changed, or when significant construction changes are made. However, some specifications of the products may be changed without any notice. When in doubt, special model numbers may be assigned to fix or establish key specifications for your application on your request. Please consult with your OMRON representative at any time to confirm actual specifications of purchased products.

DIMENSIONS AND WEIGHTS

Dimensions and weights are nominal and are not to be used for manufacturing purposes, even when tolerances are shown.

PERFORMANCE DATA

Performance data given in this catalog is provided as a guide for the user in determining suitability and does not constitute a warranty. It may represent the result of OMRON's test conditions, and the users must correlate it to actual application requirements. Actual performance is subject to the OMRON Warranty and Limitations of Liability.

ERRORS AND OMISSIONS

The information in this document has been carefully checked and is believed to be accurate; however, no responsibility is assumed for clerical, typographical, or proofreading errors, or omissions.

2008.11

In the interest of product improvement, specifications are subject to change without notice.

OMRON Corporation
Industrial Automation Company

<http://www.ia.omron.com/>

(c)Copyright OMRON Corporation 2008 All Right Reserved.