

# HOA698X/699X

## Transmissive Optoschmitt Sensor

### FEATURES

- Direct TTL interface
- Buffer or inverting logic available
- Three device output options
- Four mounting configurations
- Choice of detector aperture
- 0.125 in.(3.18 mm) slot width
- 24.0 in.(610 mm) min. 26 AWG UL 1429 wire leads

### DESCRIPTION

The HOA698X/699X series consists of an infrared emitting diode facing an Optoschmitt detector encased in a black thermoplastic housing. Detector switching takes place whenever an opaque object passes through the slot between emitter and detector. The photodetector consists of a photodiode, amplifier, voltage regulator, Schmitt trigger and various output configurations. The user can choose from available options: (1) detector aperture, (2) mounting tab configuration, (3) detector output configuration, and (4) housing material.

The HOA698X series utilizes an IR transmissive polysulfone housing which features smooth optical faces without external aperture openings; this feature is desirable when aperture blockage from airborne contaminants is a possibility. The HOA699X series employs an opaque polysulfone housing with aperture openings for use in applications in which maximum rejection of ambient light is important, and situations in which maximum position resolution is desired. The HOA698X/699X series employs plastic molded components. For additional component information see SEP8506 and SDP8XX4.

Housing material is polysulfone. Housings are soluble in chlorinated hydrocarbons and ketones. Recommended cleaning agents are methanol and isopropanol.

#### Device Polarity:

- Buffer - Output is LO when optical path is blocked.
- Inverter - Output is HI when optical path is blocked.

Wire color code and functions are:

- Red - IRED Anode      White - Detector V<sub>cc</sub>
- Black - IRED Cathode      Blue - Detector Output
- Green - Detector Ground

To specify the complete product characteristics, see PART NUMBER GUIDE.

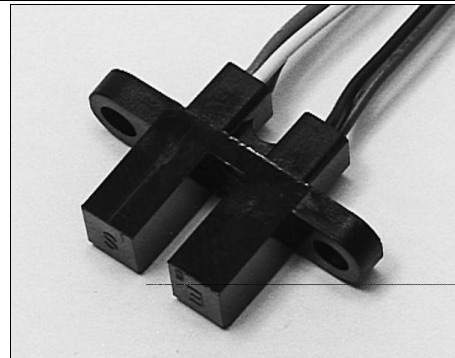

INFRA-4.TIF

### OUTLINE DIMENSIONS in inches (mm)

Tolerance    3 plc decimals    ±0.010(0.25)  
                   2 plc decimals    ±0.020(0.51)

### Package T

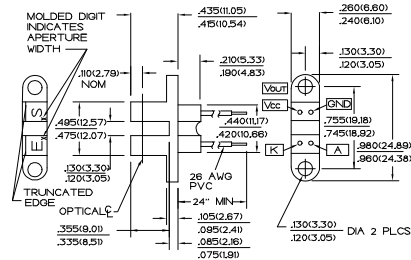

DIM\_067a.cdr

### Packages N/P/L

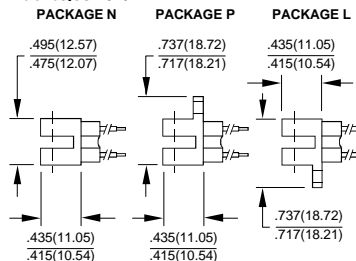

DIM\_067.dsa

# HOA698X/699X

## Transmissive Optoschmitt Sensor Totem-Pole Output

### ELECTRICAL CHARACTERISTICS (-40°C to +70°C unless otherwise noted)

PARAMETER	SYMBOL	MIN	TYP	MAX	UNITS	TEST CONDITIONS
<b>IR EMITTER</b>						
Forward Voltage	V <sub>F</sub>			1.6	V	I <sub>F</sub> =20 mA, T <sub>A</sub> =25°C
Reverse Leakage Current	I <sub>R</sub>			10	μA	V <sub>R</sub> =3 V, T <sub>A</sub> =25°C
<b>DETECTOR</b>						
Operating Supply Voltage	V <sub>CC</sub>	4.5		7.0	V	T <sub>A</sub> =25°C
Low Level Supply Current	I <sub>CC</sub> L			15	mA	V <sub>CC</sub> =5.25 V
High Level Supply Current	I <sub>CC</sub> H			15	mA	V <sub>CC</sub> =5.25 V
Low Level Output Voltage	V <sub>OL</sub>				V	V <sub>CC</sub> =4.75 V, I <sub>OL</sub> =12.8 mA
HOA6980/6990				0.4		I <sub>F</sub> =0 mA
HOA6982/6992				0.4		I <sub>F</sub> =15 mA
High Level Output Voltage	V <sub>OH</sub>				V	V <sub>CC</sub> =4.75 V, I <sub>OH</sub> =800 μA,
HOA6980/6990		2.4				I <sub>F</sub> =15 mA
HOA6982/6992		2.4				I <sub>F</sub> =0 mA
Short Circuit Output Current	I <sub>OS</sub>				mA	V <sub>CC</sub> =5.25 V, Output=GND
HOA6980/6990		-20		-100		I <sub>F</sub> =15 mA
HOA6982/6992		-20		-100		I <sub>F</sub> =0 mA
Hysteresis <sup>(2)</sup>	HYST		50		%	
Propagation Delay, Low-High, High-Low	t <sub>PLH</sub> , t <sub>PHL</sub>		5		μs	V <sub>CC</sub> =5 V, I <sub>F</sub> =0 or 15 mA
						R <sub>L</sub> =8 TTL Loads
Output Rise Time, Output Fall Time	t <sub>r</sub> , t <sub>f</sub>		70		ns	V <sub>CC</sub> =5 V, I <sub>F</sub> =0 or 15 mA
						R <sub>L</sub> =8 TTL Loads
<b>COUPLED CHARACTERISTICS</b>						
IRE Trigger Current	I <sub>FT</sub>			15	mA	V <sub>CC</sub> =5 V

#### Notes

1. It is recommended that a bypass capacitor, 0.1 μF typical, be added between V<sub>CC</sub> and GND near the device in order to stabilize power supply line.
2. Hysteresis is defined as the difference between the operating and release threshold intensities, expressed as a percentage of the operate threshold intensity.

### ABSOLUTE MAXIMUM RATINGS

(25°C Free-Air Temperature unless otherwise noted)

Operating Temperature Range	-40°C to 70°C
Storage Temperature Range	-40°C to 85°C
Soldering Temperature (5 sec)	240°C

#### IR EMITTER

Power Dissipation	100 mW <sup>(1)</sup>
Reverse Voltage	3 V
Continuous Forward Current	50 mA

#### DETECTOR

Supply Voltage:	
Totem-Pole Output	7 V <sup>(2)</sup>
All Others	12 V <sup>(2)</sup>
Duration of Output	
Short to V <sub>CC</sub> or Ground	1.0 sec.

#### Notes

1. Derate linearly at 0.78 mW/°C above 25°C.
2. Derate linearly from 25°C to 5.5 V at 70°C.

Honeywell reserves the right to make changes in order to improve design and supply the best products possible.

# Honeywell

383

# HOA698X/699X

## Transmissive Optoschmitt Sensor Open-Collector Output

### ELECTRICAL CHARACTERISTICS (-40°C to +70°C unless otherwise noted)

PARAMETER	SYMBOL	MIN	TYP	MAX	UNITS	TEST CONDITIONS
<b>IR EMITTER</b>						
Forward Voltage	$V_F$		1.6		V	$I_F=20\text{ mA}$ , $T_A=25^\circ\text{C}$
Reverse Leakage Current	$I_R$		10		$\mu\text{A}$	$V_R=3\text{ V}$ , $T_A=25^\circ\text{C}$
<b>DETECTOR</b>						
Operating Supply Voltage	$V_{CC}$	4.5	12		V	$T_A=25^\circ\text{C}$
Low Level Supply Current	$I_{CCL}$		15		mA	$V_{CC}=5.25\text{ V}$
High Level Supply Current	$I_{CCH}$		15		mA	$V_{CC}=5.25\text{ V}$
Low Level Output Voltage	$V_{OL}$				V	$V_{CC}=4.75\text{ V}$ , $I_{OL}=12.8\text{ mA}$
HOA6981/6991			0.4			$I_F=0\text{ mA}$
HOA6983/6993			0.4			$I_F=15\text{ mA}$
High Level Output Current	$I_{OH}$				$\mu\text{A}$	$V_{CC}=4.75\text{ V}$ , $V_{OH}=30\text{ V}$
HOA6981/6991			100			$I_F=15\text{ mA}$
HOA6983/6993			100			$I_F=0\text{ mA}$
Hysteresis <sup>(2)</sup>	HYST		50		%	
Propagation Delay, Low-High, High-Low	$t_{PLH}$ , $t_{PHL}$		5		$\mu\text{s}$	$V_{CC}=5\text{ V}$ , $I_F=0$ or $15\text{ mA}$ $R_L=390\ \Omega$
Output Rise Time, Output Fall Time	$t_r$ , $t_f$		70		ns	$V_{CC}=5\text{ V}$ , $I_F=0$ or $15\text{ mA}$ $R_L=390\ \Omega$
<b>COUPLED CHARACTERISTICS</b>						
IREDD Trigger Current	$I_{FT}$		15		mA	$V_{CC}=5\text{ V}$

#### Notes

- It is recommended that a bypass capacitor, 0.1  $\mu\text{F}$  typical, be added between  $V_{CC}$  and GND near the device in order to stabilize power supply line.
- Hysteresis is defined as the difference between the operating and release threshold intensities, expressed as a percentage of the operate threshold intensity.

### ABSOLUTE MAXIMUM RATINGS

(25°C Free-Air Temperature unless otherwise noted)

Operating Temperature Range	-40°C to 70°C
Storage Temperature Range	-40°C to 70°C
Soldering Temperature (5 sec)	240°C

#### IR EMITTER

Power Dissipation	100 mW <sup>(1)</sup>
Reverse Voltage	3 V
Continuous Forward Current	50 mA

#### DETECTOR

Supply Voltage:	
Totem-Pole Output	7 V <sup>(2)</sup>
All Others	12 V <sup>(2)</sup>
Duration of Output	
Short to $V_{CC}$ or Ground	1.0 sec
Applied Output Voltage	35 V

#### Notes

- Derate linearly at 0.78 mW/°C above 25°C.
- Derate linearly from 25°C to 5.5 V at 70°C.

# HOA698X/699X

Transmissive Optoschmitt Sensor  
10 kOhm Pull-Up Output

## ELECTRICAL CHARACTERISTICS (-40°C to +70°C unless otherwise noted)

PARAMETER	SYMBOL	MIN	TYP	MAX	UNITS	TEST CONDITIONS
<b>IR EMITTER</b>						
Forward Voltage	V <sub>F</sub>		1.6		V	I <sub>F</sub> =20 mA, T <sub>A</sub> =25°C
Reverse Leakage Current	I <sub>R</sub>		10		μA	V <sub>R</sub> =3 V, T <sub>A</sub> =25°C
<b>DETECTOR</b>						
Operating Supply Voltage	V <sub>CC</sub>	4.5		12	V	T <sub>A</sub> =25°C
Low Level Supply Current	I <sub>CC</sub> L			15	mA	V <sub>CC</sub> =5.25 V
High Level Supply Current	I <sub>CC</sub> H			15	mA	V <sub>CC</sub> =5.25 V
Low Level Output Voltage HOA6984/6994	V <sub>OL</sub>			0.4	V	V <sub>CC</sub> =4.75 V, I <sub>OL</sub> =12.8 mA I <sub>F</sub> =0 mA I <sub>F</sub> =15 mA
High Level Output Voltage HOA6984/6994 HOA6985/6995	V <sub>OH</sub>	2.4		2.4	V	V <sub>CC</sub> =4.75 V, I <sub>OH</sub> =100 μA, I <sub>F</sub> =15 mA I <sub>F</sub> =0 mA
Hysteresis <sup>(2)</sup>	HYST		50		%	
Propagation Delay, Low-High, High-Low	t <sub>PLH</sub> , t <sub>PHL</sub>		5		μs	V <sub>CC</sub> =5 V, I <sub>F</sub> =0 or 15 mA R <sub>L</sub> =390 Ω
Output Rise Time, Output Fall Time	t <sub>r</sub> , t <sub>f</sub>		70		ns	V <sub>CC</sub> =5 V, I <sub>F</sub> =0 or 15 mA R <sub>L</sub> =390 Ω
<b>COUPLED CHARACTERISTICS</b>						
IRED Trigger Current	I <sub>FT</sub>			15	mA	V <sub>CC</sub> =5 V

### Notes

- It is recommended that a bypass capacitor, 0.1 μF typical, be added between V<sub>CC</sub> and GND near the device in order to stabilize power supply line.
- Hysteresis is defined as the difference between the operating and release threshold intensities, expressed as a percentage of the operate threshold intensity.

## ABSOLUTE MAXIMUM RATINGS

(25°C Free-Air Temperature unless otherwise noted)

Operating Temperature Range	-40°C to 70°C
Storage Temperature Range	-40°C to 85°C
Soldering Temperature (5 sec)	240°C

### IR EMITTER

Power Dissipation	100 mW <sup>(1)</sup>
Reverse Voltage	3 V
Continuous Forward Current	50 mA

### DETECTOR

Supply Voltage:	
Totem-Pole Output	7 V <sup>(2)</sup>
All Others	12 V <sup>(2)</sup>
Duration of Output	
Short to V <sub>CC</sub> or Ground	1.0 sec

### Notes

- Derate linearly at 0.78 mW/°C above 25°C.
- Derate linearly from 25°C to 5.5 V at 70°C.

Honeywell reserves the right to make changes in order to improve design and supply the best products possible.

# Honeywell

385

# HOA698X/699X

Transmissive Optoschmitt Sensor

## SCHEMATIC FOR HOA698X/699X

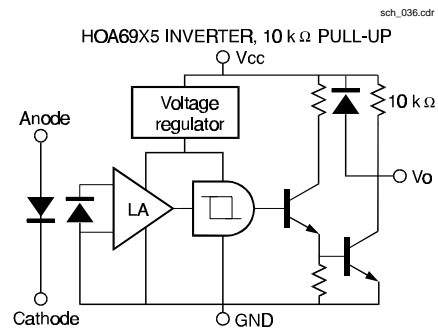
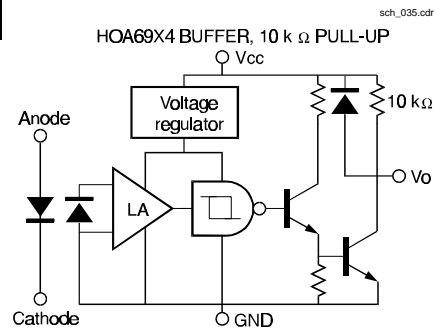
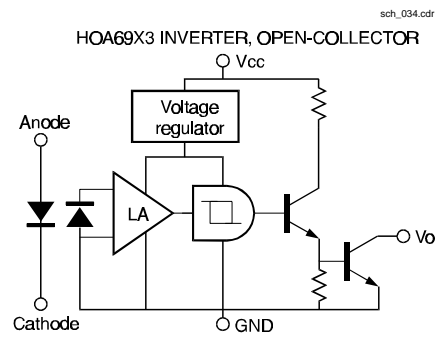
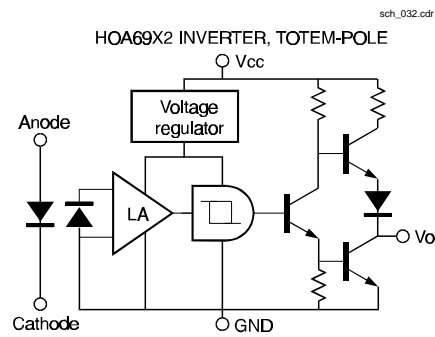
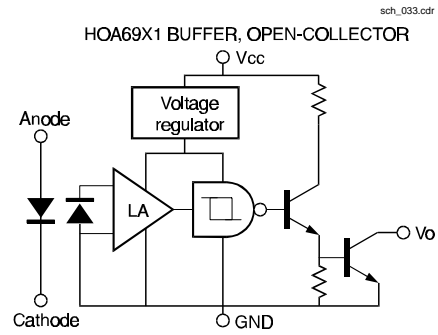
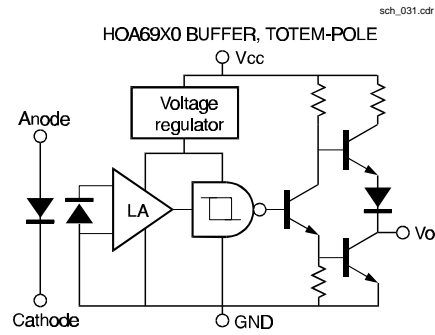

# HOA698X/699X

## Transmissive Optoschmitt Sensor

SWITCHING WAVEFORM FOR BUFFERS

cir\_013.cdr

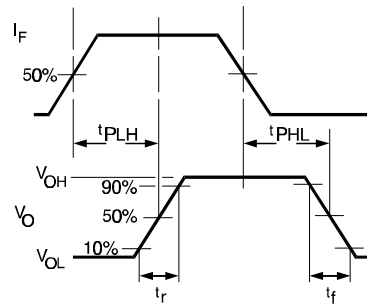
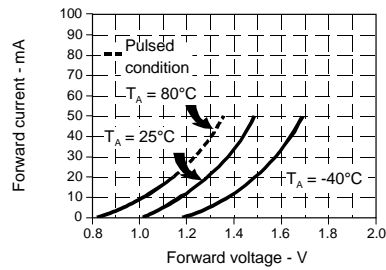

Fig. 1 IRED Forward Bias Characteristics

gra\_073.ds4



SWITCHING WAVEFORM FOR INVERTERS

cir\_011.cdr

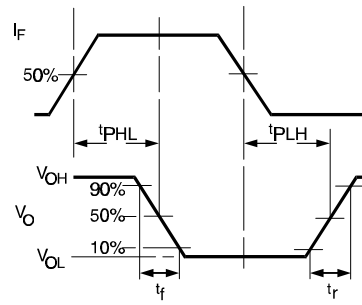
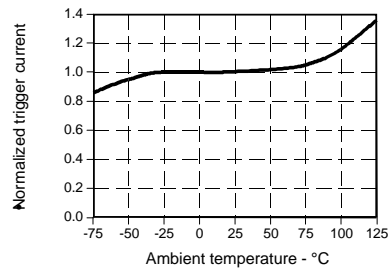

Fig. 2 IRED Trigger Current vs Temperature

gra\_098.ds4



All Performance Curves Show Typical Values

### PART NUMBER GUIDE

### HOA69XX-XXX

#### Housing Material

8 = Polysulfone, IR transmissive  
9 = Polysulfone, opaque

#### Output Configuration

0 = Totem-pole, buffer  
1 = Open-collector, buffer  
2 = Totem-pole, inverter  
3 = Open-collector, inverter  
4 = 10 kΩ pull-up, buffer  
5 = 10 kΩ pull-up, inverter

#### Aperture Width In Front Of Detector

1 = 0.010 in. (0.25 mm)  
5 = 0.050 in. (1.27 mm)  
Aperture length is 0.060 in. (1.52 mm)

#### Aperture Width In Front Of IRED

5 = 0.050 in. (1.27 mm)  
Aperture length is 0.060 in. (1.52 mm)

#### Mounting Configuration

L = Single mounting tab, emitter side  
N = No mounting tabs  
P = Single mounting tab, detector side  
T = Two mounting tabs

Honeywell reserves the right to make changes in order to improve design and supply the best products possible.

# Honeywell