

# Silizium-PIN-Fotodiode mit sehr kurzer Schaltzeit

## Silicon PIN Photodiode with Very Short Switching Time

### SFH 2400

### SFH 2400 FA

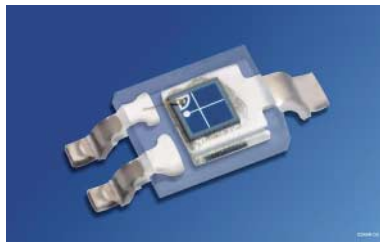

SFH 2400

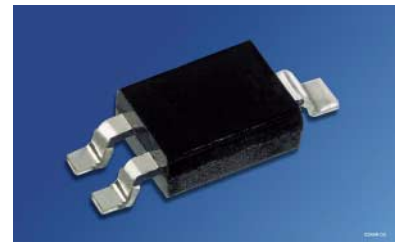

SFH 2400 FA

#### Wesentliche Merkmale

- Speziell geeignet für Anwendungen im Bereich von 400 nm bis 1100 nm (SFH 2400) und bei 880 nm (SFH 2400 FA)
- Kurze Schaltzeit (typ. 5 ns)
- SMT-Bauform, geeignet für Vapor Phase-Löten und IR-Reflow-Löten (JEDEC level 4)
- Nur gegurtet lieferbar

#### Features

- Especially suitable for applications from 400 nm to 1100 nm (SFH 2400) and of 880 nm (SFH 2400 FA)
- Short switching time (typ. 5 ns)
- SMT package, suitable for vapor phase and IR reflow soldering (JEDEC level 4)
- Available only on tape and reel

#### Anwendungen

- Industrieelektronik
- „Messen/Steuern/Regeln“
- Schnelle Lichtschranken für Gleich- und Wechsellichtbetrieb

#### Applications

- Industrial electronics
- For control and drive circuits
- Photointerrupters

Typ Type	Bestellnummer Ordering Code	Gehäuse Package
SFH 2400	Q62702-P1794	Klares Epoxy-Gießharz, Kathodenkennzeichnung: breiter Anschluß Transparent epoxy resin, cathode marking: broad lead
SFH 2400 FA	Q62702-P5035	Schwarzes Epoxy-Gießharz, Kathodenkennzeichnung: breiter Anschluß Black epoxy resin, cathode marking: broad lead

**Grenzwerte**  
**Maximum Ratings**

Bezeichnung Parameter	Symbol Symbol	Wert Value	Einheit Unit
Betriebs- und Lagertemperatur Operating and storage temperature range	$T_{op}; T_{stg}$	- 40 ... + 100	°C
Sperrspannung Reverse voltage	$V_R$	20	V
Sperrspannung $t < 2$ min Reverse voltage $t < 2$ min	$V_R$	50	V
Verlustleistung Total power dissipation	$P_{tot}$	120	mW
Wärmewiderstand für Montage auf PC-Board Thermal resistance for mounting on pcb	$R_{thJA}$	450	K/W

**Kennwerte** ( $T_A = 25$  °C)  
**Characteristics**

Bezeichnung Parameter	Symbol Symbol	Wert Value		Einheit Unit
		SFH 2400	SFH 2400 FA	
Fotostrom Photocurrent $V_R = 5$ V, Normlicht/standard light A, $T = 2856$ K, $E_V = 1000$ lx $V_R = 5$ V, $\lambda = 870$ nm, $E_e = 1$ mW/cm <sup>2</sup>	$I_P$	10 (> 6)	–	µA
	$I_P$	6.5	6.2 (≥ 3.6)	µA
Wellenlänge der max. Fotoempfindlichkeit Wavelength of max. sensitivity	$\lambda_{S\ max}$	850	900	nm
Spektraler Bereich der Fotoempfindlichkeit $S = 10\%$ von $S_{max}$ Spectral range of sensitivity $S = 10\%$ of $S_{max}$	$\lambda$	400 ... 1100	750 ... 1100	nm
Bestrahlungsempfindliche Fläche Dimensions of radiant sensitive area	$L \times B$ $L \times W$	1 × 1	1 × 1	mm × mm
Chipgröße Chip size	$L \times B$ $L \times W$	1.4 × 1.4	1.4 × 1.4	mm × mm
Halbwinkel Half angle	$\varphi$	± 60	± 60	Grad deg.

**Kennwerte** ( $T_A = 25\text{ °C}$ )

**Characteristics** (cont'd)

Bezeichnung Parameter	Symbol Symbol	Wert Value		Einheit Unit
		SFH 2400	SFH 2400 FA	
Dunkelstrom, $V_R = 20\text{ V}$ Dark current	$I_R$	1 (< 5)	1 (< 5)	nA
Leerlaufspannung Open-circuit voltage $E_V = 1000\text{ lx}$ , Normlicht/standard light A, $T = 2856\text{ K}$ $E_e = 1\text{ mW/cm}^2$ , $\lambda = 870\text{ nm}$	$V_O$ $V_O$	320 –	– 320	mV mV
Kurzschlußstrom Short-circuit current $E_V = 1000\text{ lx}$ , Normlicht/standard light A, $T = 2856\text{ K}$ $E_e = 1\text{ mW/cm}^2$ , $\lambda = 870\text{ nm}$	$I_{SC}$ $I_{SC}$	10 –	– 6.0	$\mu\text{A}$ $\mu\text{A}$
Anstiegs- und Abfallzeit des Fotostromes Rise and fall time of the photocurrent $R_L = 50\ \Omega$ ; $V_R = 20\text{ V}$ ; $\lambda = 850\text{ nm}$ ; $I_p = 800\ \mu\text{A}$	$t_r, t_f$	5	5	ns
Durchlaßspannung, $I_F = 80\text{ mA}$ , $E = 0$ Forward voltage	$V_F$	1.3	1.3	V
Kapazität, $V_R = 0\text{ V}$ , $f = 1\text{ MHz}$ , $E = 0$ Capacitance	$C_0$	11	11	pF
Temperaturkoeffizient von $V_O$ Temperature coefficient of $V_O$	$TC_V$	– 2.6	– 2.6	mV/K
Temperaturkoeffizient von $I_{SC}$ Temperature coefficient of $I_{SC}$ Normlicht/standard light A $\lambda = 870\text{ nm}$	$TC_I$	0.18 –	– 0.2	%/K
Rauschäquivalente Strahlungsleistung Noise equivalent power $V_R = 20\text{ V}$ , $\lambda = 870\text{ nm}$	$NEP$	$2.9 \times 10^{-14}$	$2.9 \times 10^{-14}$	$\frac{\text{W}}{\sqrt{\text{Hz}}}$
Nachweisgrenze, $V_R = 20\text{ V}$ , $\lambda = 870\text{ nm}$ Detection limit	$D^*$	$3.5 \times 10^{12}$	$3.5 \times 10^{12}$	$\frac{\text{cm} \times \sqrt{\text{Hz}}}{\text{W}}$

**Relative Spectral Sensitivity**  
SFH 2400,  $S_{rel} = f(\lambda)$

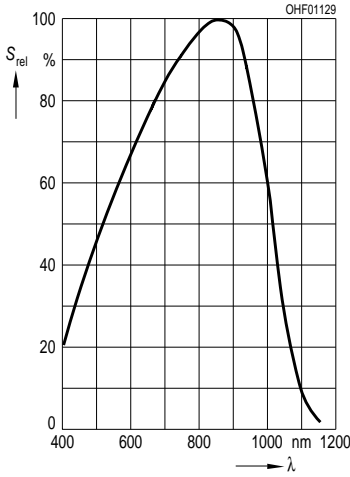

**Relative Spectr. Sensitivity**  
SFH 2400 FA,  $S_{rel} = f(\lambda)$

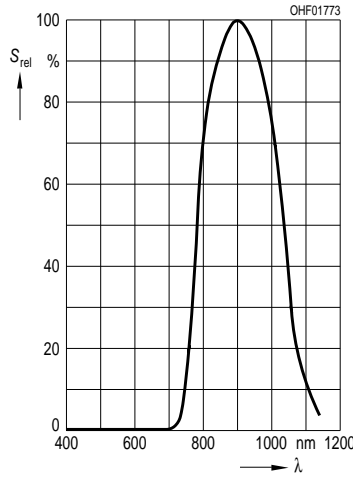

**Total Power Dissipation**  
 $P_{tot} = f(T_A)$

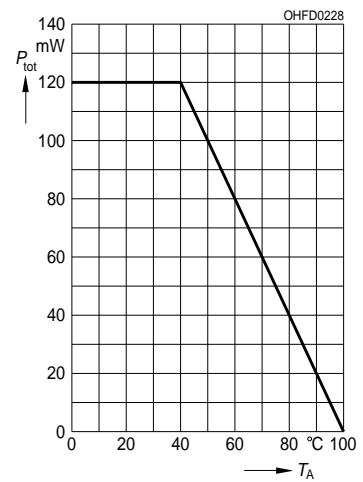

**Photocurrent  $I_P = f(E_e)$ ,  $V_R = 5 V$**   
**Open-Circuit Voltage  $V_O = f(E_e)$**   
SFH 2400 FA

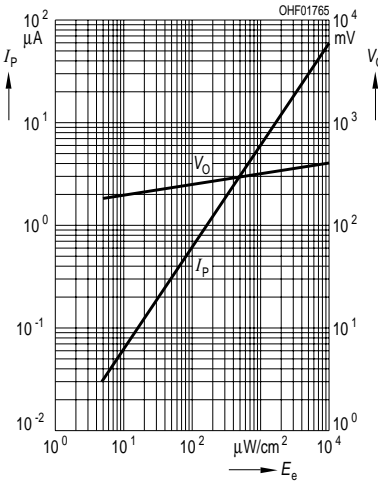

**Photocurrent  $I_P = f(E_v)$ ,  $V_R = 5 V$**   
**Open-Circuit Voltage  $V_O = f(E_v)$**   
SFH 2400

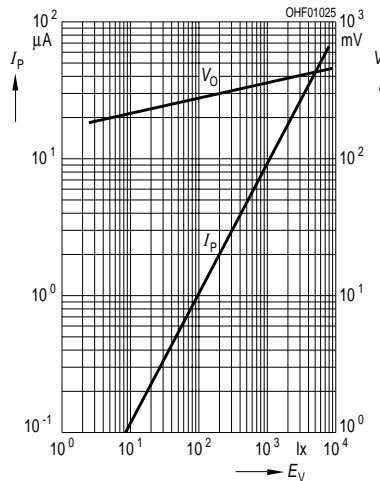

**Dark Current**  
 $I_R = f(V_R), E = 0$

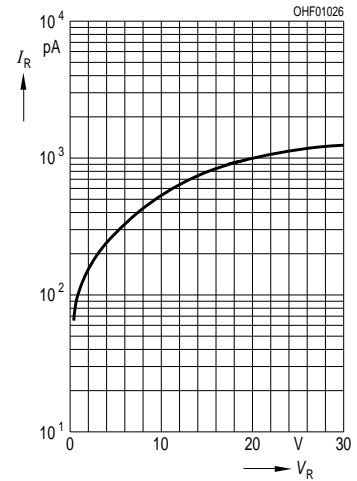

**Directional Characteristics**  
 $S_{rel} = f(\phi)$

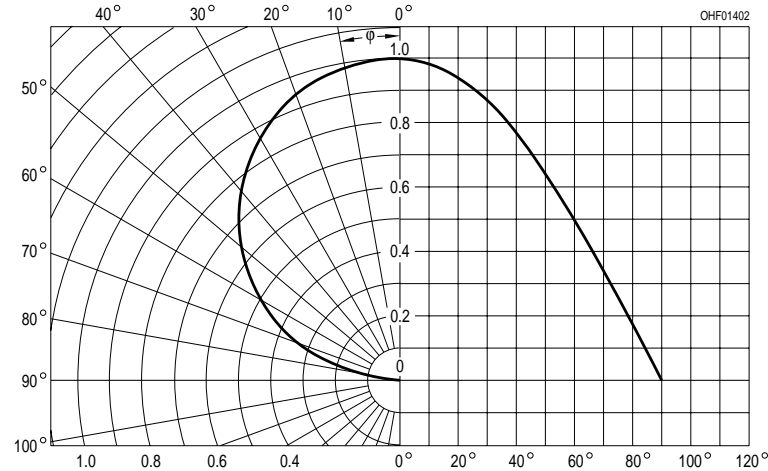

**Capacitance**  
 $C = f(V_R), f = 1 MHz, E = 0$

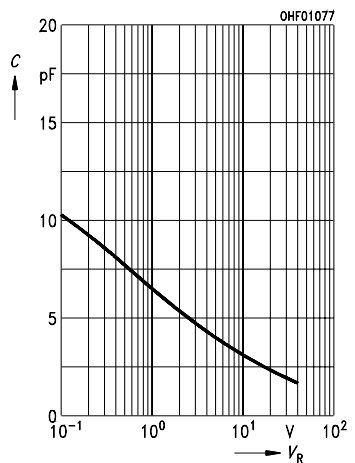

## Maßzeichnung Package Outlines

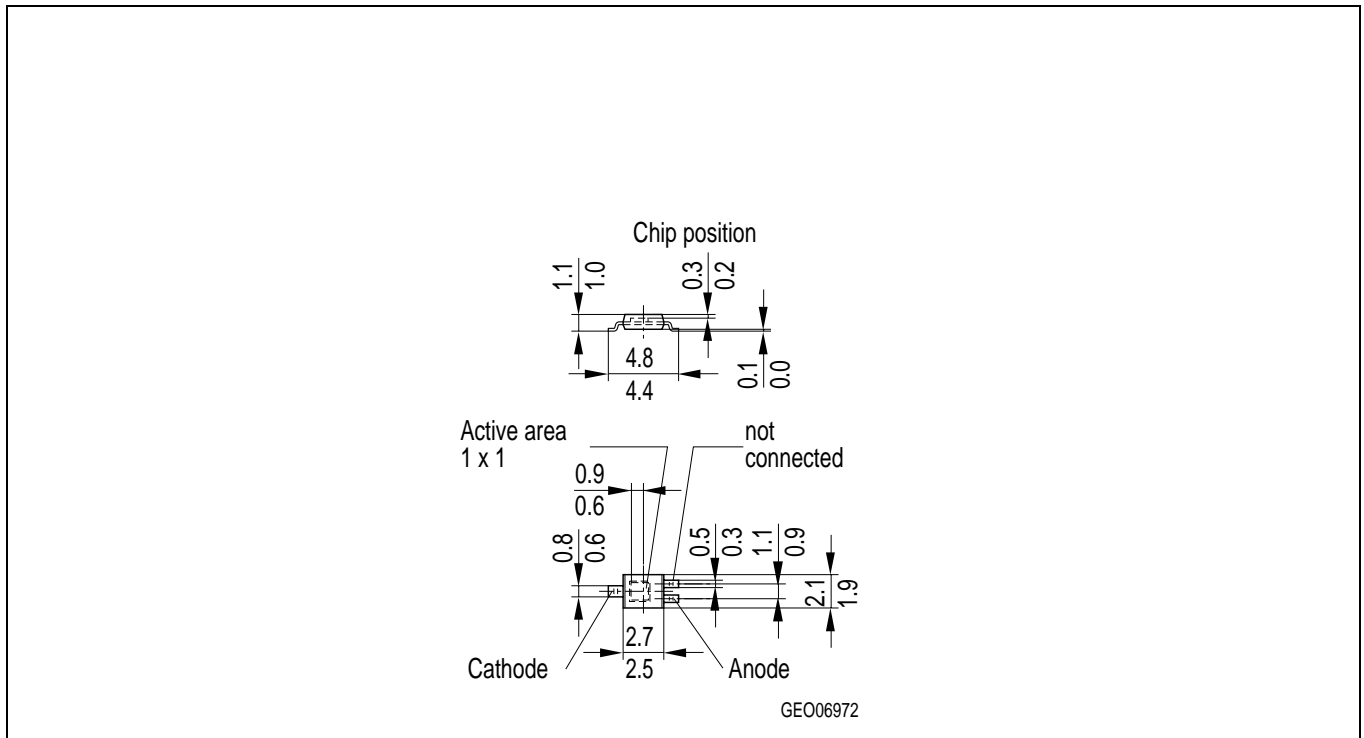

Maße werden wie folgt angegeben: mm (inch) / Dimensions are specified as follows: mm (inch).

Published by OSRAM Opto Semiconductors GmbH & Co. OHG  
Wernerwerkstrasse 2, D-93049 Regensburg

© All Rights Reserved.

### Attention please!

The information describes the type of component and shall not be considered as assured characteristics. Terms of delivery and rights to change design reserved. Due to technical requirements components may contain dangerous substances. For information on the types in question please contact our Sales Organization.

### Packing

Please use the recycling operators known to you. We can also help you – get in touch with your nearest sales office. By agreement we will take packing material back, if it is sorted. You must bear the costs of transport. For packing material that is returned to us unsorted or which we are not obliged to accept, we shall have to invoice you for any costs incurred.

**Components used in life-support devices or systems must be expressly authorized for such purpose!** Critical components<sup>1</sup>, may only be used in life-support devices or systems<sup>2</sup> with the express written approval of OSRAM OS.

<sup>1</sup> A critical component is a component used in a life-support device or system whose failure can reasonably be expected to cause the failure of that life-support device or system, or to affect its safety or effectiveness of that device or system.

<sup>2</sup> Life support devices or systems are intended (a) to be implanted in the human body, or (b) to support and/or maintain and sustain human life. If they fail, it is reasonable to assume that the health of the user may be endangered.