

PHOTONIC DETECTORS INC.

Silicon Photodiode, Blue Enhanced Photoconductive Type PDB-C137, with daylight filter Type PDB-C137F

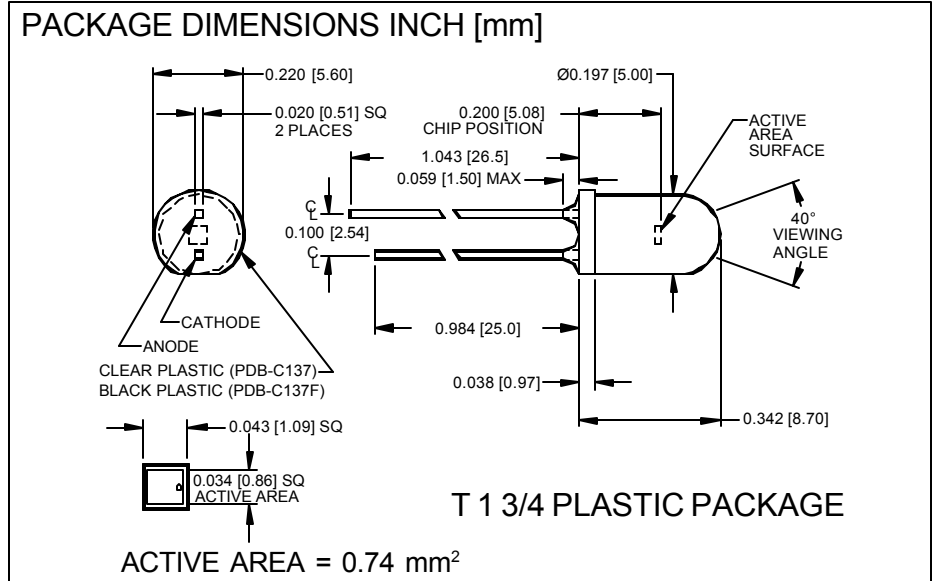

FEATURES

- Photoconductive
- High speed
- Low cost

DESCRIPTION: The **PDB-C137** detector is a 0.74 mm² planar pin photodiode packaged in a T 1 3/4, water clear plastic housing. Designed for high speed, low capacitance, photoconductive applications. The **PDB-C137F** includes a daylight filter.

APPLICATIONS

- Smoke detectors
- Light dimmers
- TV & VCR remotes
- I.R. receivers

ABSOLUTE MAXIMUM RATING (TA=25°C unless otherwise noted)

SYMBOL	PARAMETER	MIN	MAX	UNITS
V _{BR}	Reverse Voltage		50	V
T _{STG}	Storage Temperature	-40	+100	°C
T _O	Operating Temperature Range	-40	+80	°C
T _S	Soldering Temperature*		+260	°C
I _L	Light Current		500	mA

*1/16 inch from case for 3 secs max

SPECTRAL RESPONSE

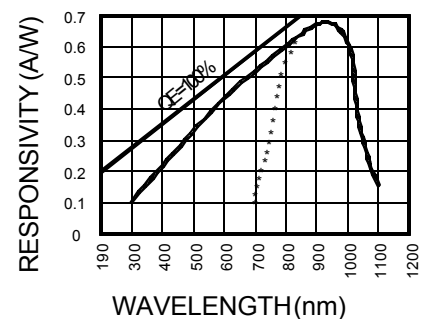

ELECTRO-OPTICAL CHARACTERISTICS (TA=25°C unless otherwise noted)

SYMBOL	CHARACTERISTIC	TEST CONDITIONS	MIN	TYP	MAX	UNITS
I _{SC}	Short Circuit Current	H = 100 fc, 2850 K	28	35		μA
I _D	Dark Current	H = 0, V _R = 10 V		2	10	nA
R _{SH}	Shunt Resistance	H = 0, V _R = 10 mV	500	1000		MΩ
TCR _{SH}	RSH Temp. Coefficient	H = 0, V _R = 10 mV		-8		% / °C
C _J	Junction Capacitance	H = 0, V _R = 0 V*		4		pF
λrange	Spectral Application Range (without daylight filter)**		400		1100	nm
λp	Spectral Response - Peak			950		nm
V _{BR}	Breakdown Voltage	I = 10 μA	15	25		V
NEP	Noise Equivalent Power	V _R = 10 V @ Peak		1.5x10 ⁻¹⁴		W/√Hz
tr	Response Time	RL = 1 KΩ V _R = 10 V		10		nS

Information in this technical data sheet is believed to be correct and reliable. However, no responsibility is assumed for possible inaccuracies or omission. Specifications are subject to change without notice. *f = 1 MHz, ** daylight filter = 700 - 1100 nm

[FORMNO. 100-PDB-C137 REV B]