



This is designed for use in non-turbulent water, with fairly constant ambient temperature, such as in indoor tanks or covered reservoirs. The switching element is a microswitch, having UL, VDE and CENELEC approvals, with either 10 or 20 Amp contacts, activated by a moving stainless ball and having an electrical life of 200,000 operations.



- **Cable mounting**
- **100 metre depth Capability**

Technical Specifications		10 Amp	20 Amp
Switching Power Max.	AC	750 VA	1500 VA
	DC	180W	360W
Switching Current Max. Resistive	Resistive	10 Amps	20 Amps
	DC Inductive	1Amp	2 Amps
	AC Inductive	4 Amps	8 Amps
Switching Voltage Max.	DC	110	110
	AC	250	250

Material Specifications		
Body Material		High Density Polyethylene
Standard Cable		5 metres PVC sheathed 3 Core
W cable for Drinking Water		WRAS approved 3 core cable
U cable for Fuel Oils		Polyurethane sheathed 3 core cable
Temperature range	°C	0 to 55°C
	°F	+ 32 / +131
Max. working pressure		10bar

Mechanical Dimensions

All dimensions are in millimeters (inches)

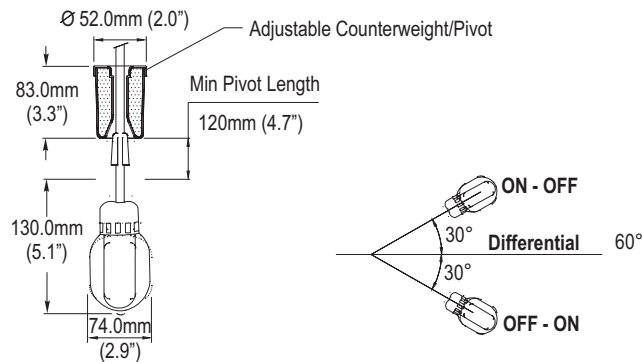

USA

Cynergy3 Components
2320 Paseo de las Americas, Suite 104
San Diego, CA 92154
Sales & Tech Support (866) 258-5057
Email: sales@cynergy3.com

EUROPE - UK

Cynergy3 Components Ltd.
7 Cobham Road
Ferndown Industrial Estate
Wimborne, Dorset BH21 7PE
Telephone +44 (0) 1202 897969
Fax +44 (0) 1202 891918
Email:sales@cynergy3.com